



Mudrick Capital Acquisition Corporation & Hycroft Mining Corporation



May 2020

Important Information

This presentation (the “Presentation”) has been prepared solely for, and is being delivered on a confidential basis to, persons considering a possible business relationship with Hycroft Mining Corporation (“Hycroft” or the “Company”) in connection with the proposed business combination with Mudrick Capital Acquisition Corporation (“Mudrick”). This Presentation is for informational purposes only. The information herein may not be reproduced, further distributed to any other person or published, in whole or in part, for any purpose whatsoever.

Financial Projections

This presentation contains financial forecasts regarding certain financial metrics of the Company. Neither the independent auditors of the Company or Mudrick have audited, reviewed, compiled, or performed any procedures with respect to the projections for the purpose of their inclusion in this Presentation, and accordingly, neither of them expressed an opinion or provided any other form of assurance with respect thereto for the purpose of this presentation. These projections should not be relied upon as being necessarily indicative of future results. Neither Mudrick nor Hycroft undertakes any commitment to update or revise the projections, whether as a result of new information, future events, or otherwise.

In this presentation, certain of the above-mentioned projected information has been repeated (in each case, with an indication that the information is an estimate and is subject to the qualifications presented herein), for purposes of providing comparisons with historical data. The assumptions and estimates underlying the prospective financial information are inherently uncertain and are subject to a wide variety of significant business, economic, and competitive risks and uncertainties that could cause actual results to differ materially from those contained in the prospective financial information. Accordingly, there can be no assurance that the prospective forecasts are indicative of the future performance of Mudrick or Hycroft or that actual results will not differ materially from those presented in the prospective financial information. Inclusion of the prospective financial information in this presentation should not be regarded as a representation by any person that the results contained in the prospective financial information will be achieved.

Cautionary Note Regarding Forward-Looking Statements

In addition to historical information, this presentation and the documents incorporated by reference in this presentation and other written reports and oral statements made from time to time by us may contain forward-looking statements.

All statements, other than statements of historical fact, included herein or incorporated by reference, that address activities, events or developments that we expect or anticipate will or may occur in the future, are forward-looking statements. Generally, these forward-looking statements can be identified by the use of forward-looking terminology such as “estimate”, “plan”, “anticipate”, “expect”, “intend”, “believe”, “project”, “target”, “budget”, “may”, “can”, “will”, “would”, “could”, “should”, “seeks”, or “scheduled to”, or other similar words, or negatives of these terms or other variations of these terms or comparable language or any discussion of strategy or intentions. Forward-looking statements address activities, events or developments that the Company expects or anticipates will or may occur in the future and are based on current expectations and assumptions. These statements involve known and unknown risks, uncertainties, assumptions and other factors which may cause our actual results, performance or achievements to be materially different from any results, performance or achievements expressed or implied by such forward-looking statements, and include, but are not limited to the time and cost of construction and operation of existing and new leach pads; the feasibility and efficacy of processing sulfide ores using a pre-oxidation and heap leach process; the effectiveness and control of the oxidation process; the processing and production of gold and silver from the heap leach pads; the availability of personnel and equipment to operate the mine; the future price of gold and silver; the timing and amount of estimated future production, costs of production, capital expenditures and requirements for additional capital; cash flow provided by operating activities before changes in working capital; government regulation of mining operations; environmental risks; unanticipated reclamation expenses; title disputes or claims and limitations on insurance coverage; total cash cost per ounce, total cash cost net of by-product per ounce, all-in sustaining cost per ounce, capital expenditures, corporate general and administration expenses; sustaining and project capital expenditures; the expected working capital requirements; the sufficiency of capital resources and the availability of additional funding as and when required to meet operational and strategic needs; the expected depreciation and depletion rates; changes in mining laws and regulations; the uncertainty in the estimation of mineral resource and mineral reserve estimates; the cost and timing of sustaining capital projects; the uncertainty in geologic, hydrological, metallurgical and geotechnical studies and opinions; infrastructure risks, including access to water and power; the expectation of meeting production targets; the expected timeline for achieving mining rates, oxidation rates and percentage recoveries included in the Hycroft Technical Report; projected net present values and internal rates of return under the Hycroft Technical Report; risks associated with competition; contractor, labor and employment risks; the adverse effects of COVID-19 on our business and dependence on key management personnel and executives. Although the Company has attempted to identify important factors that could cause actual results, performance or achievements to differ materially from those described in forward-looking statements, there may be other factors that cause results, performance or achievements not to be as anticipated, estimated or intended. There can be no assurance that such statements will prove to be accurate, as actual results, performance and achievements and future events could differ materially from those anticipated in such statements. Accordingly, readers should not place undue reliance on forward-looking statements. Further, the financial and other projections are preliminary and subject to change. The Company undertakes no obligation to update or revise these forward-looking statements to reflect events or circumstances that arise after the date made or to reflect the occurrence of unanticipated events, unless required by applicable law. Projections are inherently subject to substantial and numerous uncertainties and to a wide variety of significant business, economic and competitive risks, and the assumptions underlying the projections may be inaccurate. Therefore, the actual results achieved may vary significantly from the forecasts, and the variations may be material.

All dollar amounts are expressed in US dollars, unless otherwise stated.

Important Information (cntd.)

No Representations or Warranties

This presentation does not purport to contain all of the information that may be required to evaluate a possible transaction. No representation or warranty, express or implied, is or will be given by Mudrick or Hycroft or any of their respective affiliates, directors, officers, employees, or advisers or any other person as to the accuracy or completeness of the information in this presentation (including as to the accuracy or reasonableness of statements, estimates, targets, projections, assumptions, or judgments) or any other written, oral, or other communications transmitted or otherwise made available to any party in the course of its evaluation of a possible transaction, and no responsibility or liability whatsoever is accepted for the accuracy or sufficiency thereof or for any errors, omissions, or misstatements, negligent or otherwise, relating thereto.

Accordingly, none of Mudrick or Hycroft or any of their respective affiliates, directors, officers, employees, or advisers or any other person shall be liable for any direct, indirect, or consequential loss or damages suffered by any person as a result of relying on any statement in or omission from this presentation and any such liability is expressly disclaimed. This presentation is not intended to constitute and should not be construed as investment advice and does not constitute investment, tax, or legal advice. Certain information contained herein has been derived from sources prepared by third parties. While such information is believed to be reliable for the purposes used herein, none of Mudrick's, Hycroft's, their respective affiliates, nor Mudrick's, Hycroft's or their affiliates' directors, officers, employees, members, partners, shareholders, or agents makes any representation or warranty with respect to the accuracy of such information.

Industry and Market Data

In this presentation, Mudrick and Hycroft rely on and refer to information and statistics regarding Hycroft and certain of its competitors and other industry data. The information and statistics are from third-party sources, including reports by market research firms.

Additional Information and Where to Find It

In connection with the proposed business combination, Mudrick has filed with the Securities and Exchange Commission (the "SEC") a Joint Proxy Statement/Prospectus for Special Meeting of Mudrick Capital Acquisition Corporation and Hycroft Mining Corporation, dated and effective as of May 7, 2020 (the "Prospectus"), which includes a proxy statement/prospectus with respect to the securities to be issued in connection with the transactions contemplated by the proposed business combination. The Prospectus contains important information about the transactions contemplated by the proposed business combination and related matters. INVESTORS AND SECURITY HOLDERS OF MUDRICK AND HYCROFT ARE URGED AND ADVISED TO CAREFULLY READ THE PROSPECTUS. The Prospectus and other relevant materials and any other documents filed by Mudrick with the SEC may be obtained free of charge at the SEC's website, at www.sec.gov. In addition, shareholders will be able to obtain free copies of the Prospectus by directing a request to: Mudrick Capital Acquisition Corporation, 527 Madison Avenue, 6th Floor, New York, NY 10022 or by email at info@mudrickcapital.com.

Participants in the Solicitation

Mudrick and its directors and executive officers may be deemed to be participants in the solicitation of proxies from Mudrick's stockholders in connection with the proposed business combination. Information about Mudrick's directors and executive officers is set forth in Mudrick's Annual Report on Form 10-K for the fiscal year ended December 31, 2019, which was filed with the SEC on March 12, 2020. These documents are available free of charge at the SEC's web site at www.sec.gov, or by directing a request to: Mudrick Capital Acquisition Corporation, 527 Madison Avenue, 6th Floor, New York, NY 10022 or by email at info@mudrickcapital.com. Information regarding the persons who may, under SEC rules, be deemed participants in the solicitation of proxies to Mudrick stockholders in connection with the proposed business combination will be set forth in the Registration Statement for the proposed business combination when available. Additional information regarding the interests of participants in the solicitation of proxies in connection with the proposed business combination is included in the Prospectus.

No Offer or Solicitation

This presentation is for informational purposes only and is neither an offer to purchase, nor a solicitation of an offer to sell, subscribe for or buy any securities or the solicitation of any vote in any jurisdiction pursuant to the proposed business combination or otherwise, nor shall there be any sale, issuance or transfer of securities in any jurisdiction in contravention of applicable law. No offer of securities shall be made except by means of a prospectus meeting the requirements of Section 10 of the Securities Act of 1933, as amended.

Executives

Hycroft Management



Randy Buffington
Executive Chairman,
President and Chief
Executive Officer

- Over 28 years of management, operations, engineering, and construction experience through various senior positions at globally focused mid-tier and senior mining companies
- Randy has spent over 6 years at Hycroft and its predecessor, Allied Nevada
- Most recently at Coeur d'Alene Mines Corporation, where Randy was Senior VP, Operations and was responsible for the safe operation of five mines located in Bolivia, Argentina, Mexico, and the United States
- Prior to that, Randy served in a variety of general management roles with Barrick Gold, including: Managing Director of Barrick's Lumwana copper mine in Zambia, General Manager of Barrick's Goldstrike mine complex, and General Manager of its Ruby Hill and Bald Mountain mines in Nevada
- Randy has a Masters degree in Civil Engineering



Stephen Jones
Executive Vice
President and Chief
Financial Officer

- Over 20 years of management, marketing and finance experience at globally focused mid-tier and senior mining and oil & gas companies
- Steve has spent over 7 years at Hycroft and its predecessor, Allied Nevada
- Prior to Hycroft, Stephen was the President, CFO and Director of EPM Mining Ventures for which he raised the initial project funding as well as Senior VP and CFO for Katanaga Mining from 2006 to 2008 where he raised ~\$300 mm through various debt and equity financing instruments enabling the restart of underground and open-pit mines in the DRC
- Other previous roles include Managing Director of El Paso in the oil & gas sector and Senior VP and CFO of Freeport McMoRan Copper and Gold
- Steve holds his B.B.A. in Finance from Texas A&M University and is a CPA

Hycroft Mine Overview

Existing Operation & Deposit



Location

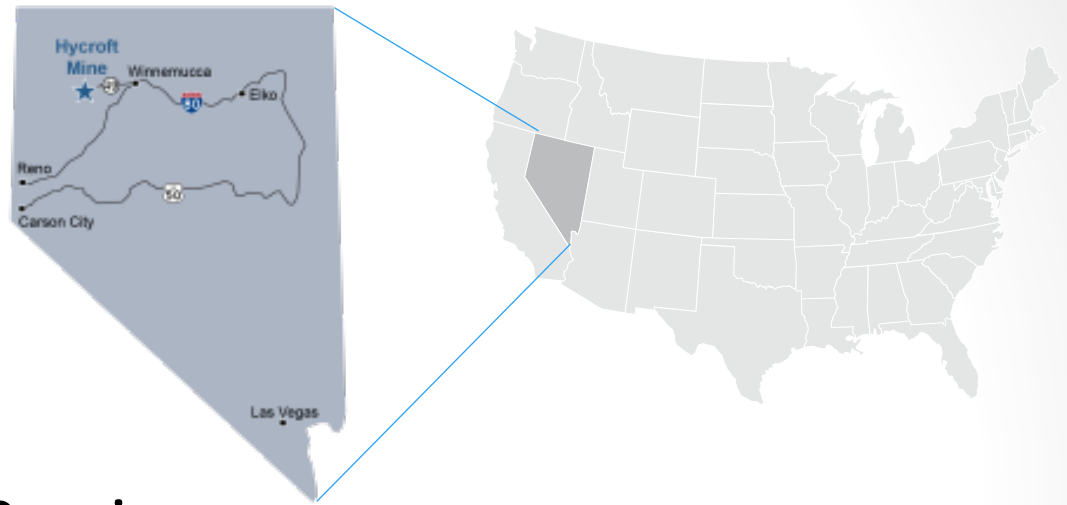

Overview

- Hycroft Mining is a production stage gold and silver mining company operating the Hycroft Mine
 - Open pit heap leach mining operation located 54 miles west of Winnemucca, Nevada
- One of the world's largest deposits with a resource of ~31 Moz Au Eq^(1,2)
 - Proven and probable mineral reserves of ~18 Moz Au Eq^(1,2)
- Low-capital expansion plans provide optionality and cumulative mine site FCF⁽³⁾ of \$123 M during first 5 years⁽⁴⁾
- The Company has recently restarted operations
 - Secured funding from current investors for the restart of the operation
 - Weekly doré sales and metal pours since August 2019
 - Commissioned crushing system with manufacturer

Source: Hycroft Mining Management, company filings

1. Resources include Measured, Indicated and Inferred Resources, AuEq calculated using a Au:Ag ratio of 75:1.
2. See "Cautionary Note to US Investors Regarding Reserves and Resources."
3. Free Cash Flow ("FCF") is a non-GAAP financial measure, see "Cautionary Note on Non-GAAP Financial Measures" section.
4. Based on August 2019 Feasibility Study (effective date of July 31, 2019), using sales prices per ounce of \$1,300 Au / \$17.33 Ag, see "Cautionary Note Regarding Forward-Looking Statements" section.

Hycroft Mine Overview (cont'd)

Hycroft Mine Overview

- Senior-scale asset with expected average annual production of approximately 366 koz Au Eq.⁽¹⁾
- Management has developed a “capital light” restart plan that is being executed over 2019, 2020 and early 2021 after which the mine will be ramped up to Feasibility Study production levels
- Currently mining stockpiles and in-pit drill and blast tons
 - Hycroft has fully constructed mine and processing facilities
 - Crusher commissioning completed
- All operating and environmental permits are in place for initial mining and heap leach operations, with EIS recently approved
- Proprietary process⁽²⁾ oxidizes sulfides prior to leaching
 - Successful recoveries in excess of 80% have been demonstrated⁽³⁾

10-Year Operating Profile⁽¹⁾

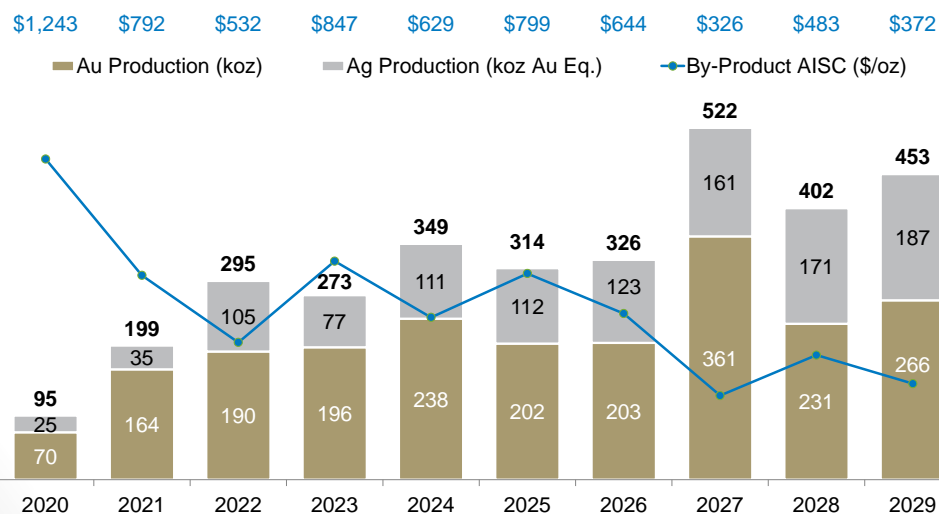

Source: August 2019 Feasibility Study (effective date of July 31, 2019)

1. Based on 34 years of mining and processing mineral reserves. See “Cautionary Note to US Investors Regarding Reserves and Resources” and “Cautionary Note Regarding Forward-Looking Statements”.
2. Patent pending.
3. Based on leach pad Cell 1 results to date of Brimstone ore.

Hycroft Project Feasibility Study Highlights⁽¹⁾

August 2019 Feasibility Study (Preliminary Draft)

Asset Details	
Location	Nevada, USA
Stage	Ramp up / Production
Mine Type	Open Pit
Process Description	Heap Leach
Gold Reserves (k oz)	11,996
Silver Reserves (k oz)	481,399
AuEq Reserves (k oz)	18,413
Metal Prices Inputs for Reserves (\$ oz)	\$1,200 / \$16.50

Operating Details	
First Gold	Aug-19
Mine Life (years)	34
Strip Ratio (ratio)	1.17
Operating Cost (\$ / ton)	\$8.54
LOM Ore Processed (kt)	1,133,060
Gold / Silver Recovery (%)	65% / 71%
LOM Payable Gold Production (k oz)	7,845
LOM Payable Silver Production (k oz)	344,097
LOM Payable AuEq Production (k oz)	12,432

Financial Details		
After-Tax NPV _{5%}	(\$ mm)	\$2,078
IRR	(%)	147%
After-Tax Payback	(years)	2.6
Initial 5-YR Capital Costs	(\$ mm)	\$225
LOM Total Sustaining Capital	(\$ mm)	\$533
Gold / Silver Price Assumptions	(\$ oz)	\$1,300 / \$17.33

Key Investment Highlights

1

One of the World's Largest Precious Metals Deposits

*18 million ounces of gold equivalent reserves
31 million ounces of gold equivalent resources*

2

Restart Under Way, Weekly Gold Sales; Ramp Up Underway

*Producing gold since August 2019
Averaged over 500,000 tons placed on the leach pads monthly between July 2019 and April 2020
Expect to increase to 700,000 tons in May 2020 and 850,000 tons per month in Q4*

3

Capital-Light, Permitted Expansion; Leach Pads Majority of Capex

*Initial capex (years 1 and 2) only 3% of NPV; initial 5-year capital expenditures forecast at \$225 mm
\$400 mm of existing infrastructure - includes crushers, Merrill Crowe facilities, refinery, 4-bay truck shop, mine office, electrical and water utilities*

4

Improved Heap Leach Recoveries Using Pre-Oxidation

*Technical report forecasts average recoveries of 65% gold and 71% silver
50,000 ton leach pads demonstrate commercial scale recoveries in excess of those used in the technical report*

5

Economics Highly-Leveraged to Metal Prices Above Feasibility Study

*\$2.1 bn NPV_{5%} using \$1,300 / oz Au; \$17.33 / oz Ag; NPV_{5%} in excess of \$3 bn at current spot prices
Every \$100 / oz change in Au is \$300 mm of NPV_{5%}
Every \$1.00 / oz change in Ag is \$125 mm of NPV_{5%}*

6

Value Proposition

*Median Junior Producer Trading P/NAV Multiple - 0.65x
Offer of equity is at 0.28x P/NAV*

One of the World's Largest Precious Metals Deposits

Substantial Scale

- Hycroft ranks among the 25 largest gold deposits in the world based on resource size, and the second largest in the U.S.
- 34-year mine life provides strong leverage to gold and silver prices, with expected production approximately 366 payable gold equivalent koz per year, including an average of over 10 moz Ag annually
- Potential resource conversion provides additional production upside and mine life extension
- Substantial scale will appeal to senior producers once project has demonstrated economics / production success

Reserves and Resources^(1,2)

Category	Tons (000s)	Grades		Contained Ounces (000s)		
		Au	Ag	Au	Ag	Au Eq
Proven & Probable	1,133,061	0.011	0.425	11,996	481,399	18,413
Measured & Indicated	393,922	0.009	0.277	3,699	108,992	5,152
Inferred	599,062	0.010	0.217	5,769	129,754	7,499
M&I + I	992,984	0.010	0.240	9,468	238,746	12,651

Higher M&I Grades than Other Properties

Property	Tons	Grade			Contained Ounces		
		Au	Ag	AuEq	Au	Ag	AuEq
Round Mountain	231,116	0.021	0.013	0.022	4,949	3,028	4,989
Bald Mountain	268,390	0.017	---	0.017	4,641	---	4,641
Marigold	407,960	0.014	---	0.014	5,660	---	5,660
Hycroft	393,922	0.009	0.277	0.013	3,699	108,992	5,152
Paracatu	946,032	0.012	---	0.012	10,951	---	10,951
Fort Knox	466,424	0.010	---	0.010	4,833	---	4,833
Coeur Rochester	440,574	0.003	0.400	0.008	1,138	176,054	3,486

World's Largest Primary Gold Deposits (Moz Au Eq.)^(1,2,3,4)

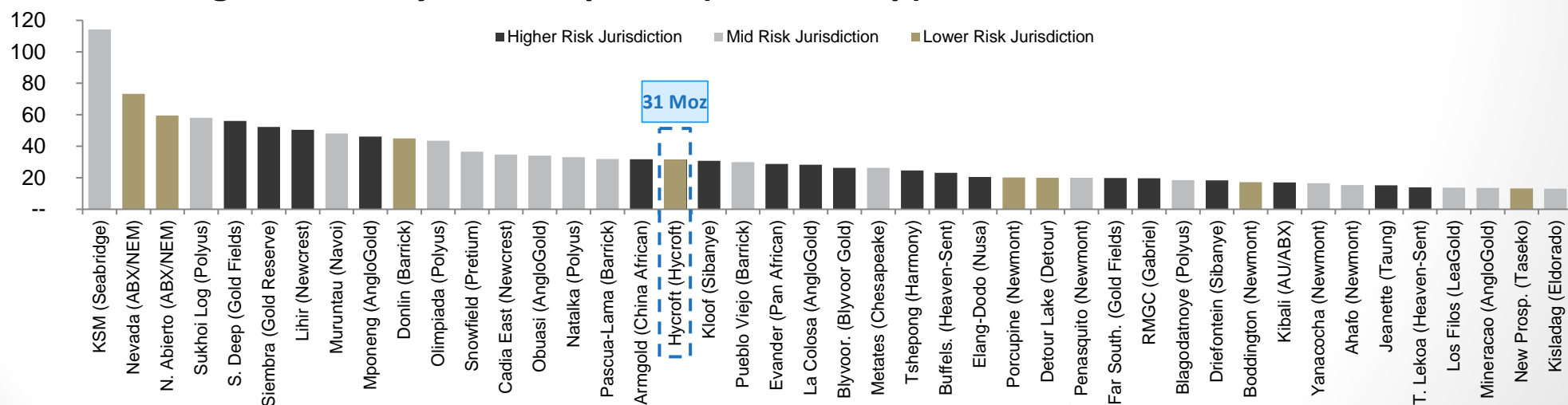

Source: August 2019 Feasibility Study (effective date of July 31, 2019), Company filings, Fraser Institute, SNL, street research

1. AuEq. calculated based on feasibility study commodity pricing of \$1,300/oz Au and \$17.33/oz Ag; includes stockpiled sulfide ore.

2. See "Cautionary Note to US Investors Regarding Reserves and Resources."

3. Presents gold and gold equivalent silver ounces converted at LT street consensus pricing of \$1,350/oz Au and \$17.75/oz Ag.

4. Lower risk denotes a Fraser Institute Policy Perception Index score above 75; mid risk indicates a Policy Perception Index score between 50 and 75; higher risk indicates a Policy Perception Index score below 50.

Relative Operational Performance

All figures in US\$

Estimated Average Annual Production (koz Au Eq.)

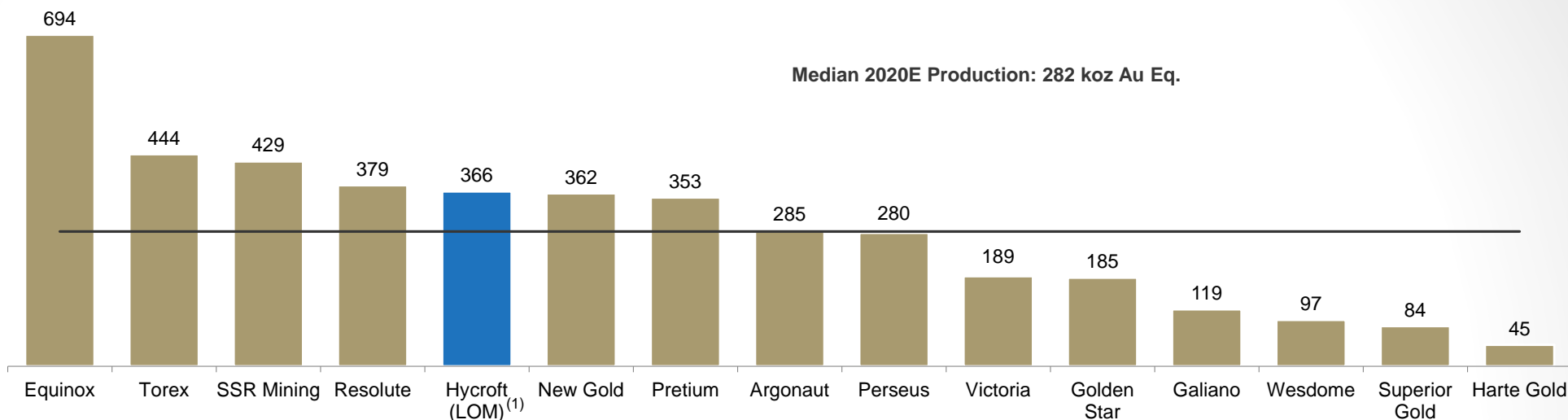

Estimated Average Annual By-Product Cash Costs² (\$/oz Au)

Hycroft Co-Product
Total Cash Costs:
~\$827/oz Au Eq.

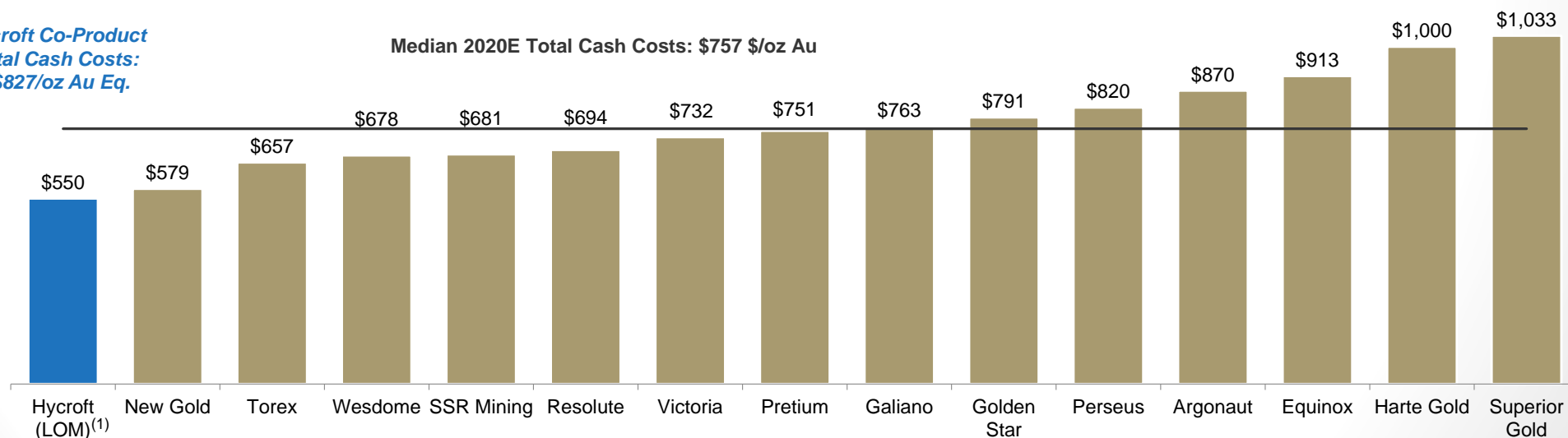

Source: Company filings, street research

Note: Estimates as at Feb-2020 to illustrate peers pre-Covid figures; Medians exclude Hycroft; Equinox shown pro forma acquisition of Leagold and Argonaut shown pro forma acquisition of Alio.

1. Based on the life of mine average from Hycroft's 2019 feasibility study.

2. By-product cash costs is a non-GAAP financial measures, see "Cautionary Note on Non-GAAP Financial Measures" section.

Financing Overview

All figures in US\$

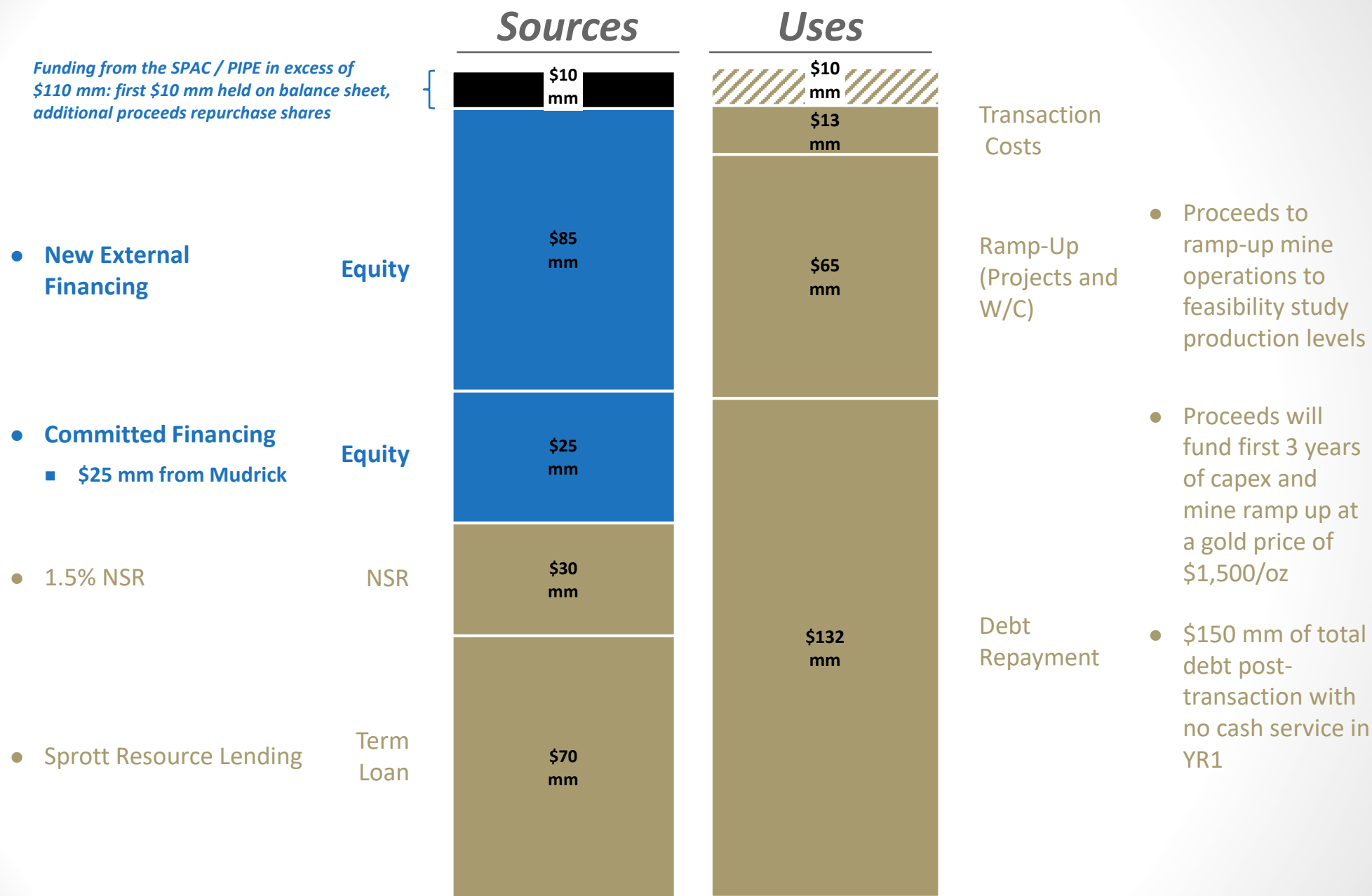

Source: Company filings, Sprott Credit Agreement
 Note: Current cash balance excluded from sources and uses.

Value Proposition

All figures in US\$

Key Metrics	
Implied Share Price	\$10.00 / share
Implied Purchase Multiple	0.28x⁽¹⁾
Med. Junior Multiple	0.65x

Junior Producer Trading P/NAV Multiples

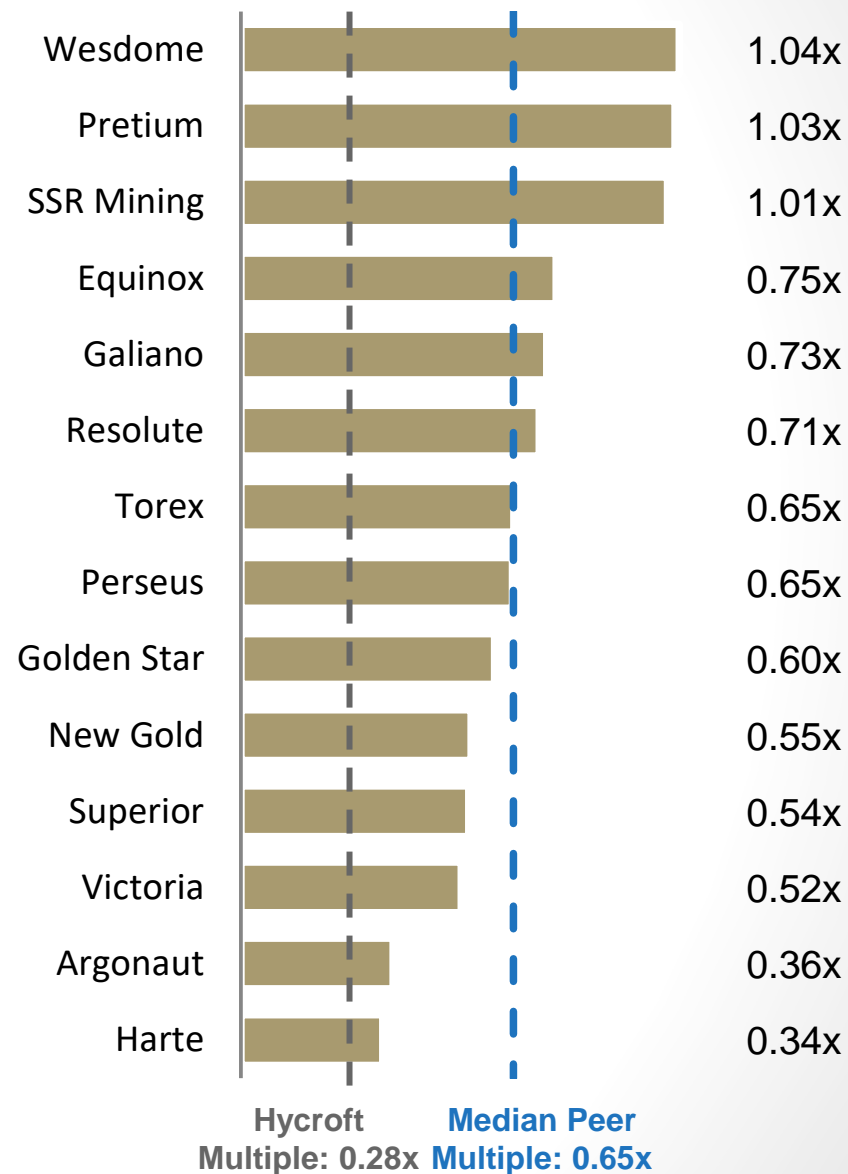

Source: Company filings, FactSet, S-4, street research

Note: Priced to 17-Apr-20.

1. Based on Hycroft implied post transaction 50 mm basic shares outstanding and NAV of \$1.8 bn adjusted from Hycroft's 2019 feasibility study.

Transaction Overview – No Redemptions

All figures in US\$

Pro Forma Equity Ownership⁽¹⁾

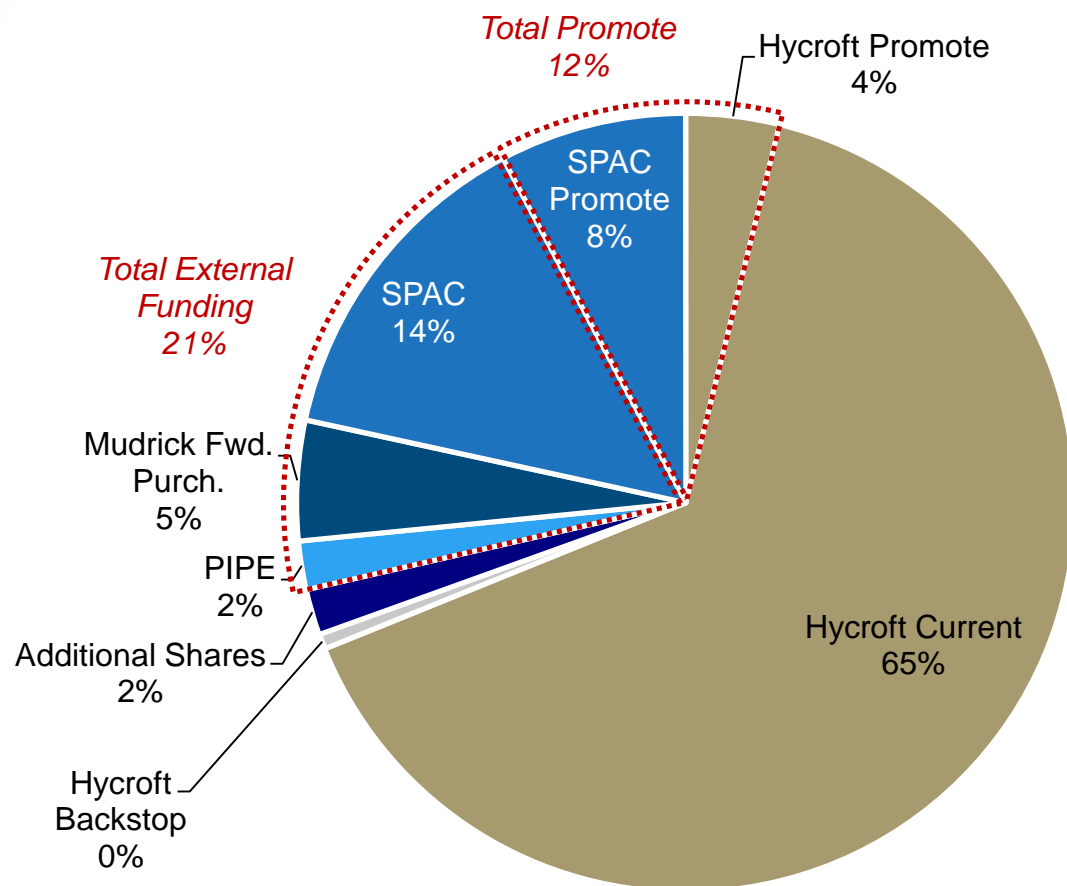

NAV Build-Up

Components	Build-Up
	(\$ mm)
Hycroft NPV ⁽²⁾	\$1,994
Pro Forma Debt:	
SRL Debt	(\$70)
New Note	(\$80)
Cash	\$65
LOM Discounted Corp. G&A ⁽³⁾	(\$121)
NAV	\$1,787
Implied P / NAV Mult.	0.28x

Source: Company filings, S-4

1. Equity value assumed to be distributed pro rata amongst equity holders and equitized debt holders.
2. Shown net of SRL royalty.
3. Includes average annual G&A of \$7.5 mm over the 34 year mine life discounted at 5%.

Transaction Overview – Backstopped

All figures in US\$

Pro Forma Equity Ownership⁽¹⁾

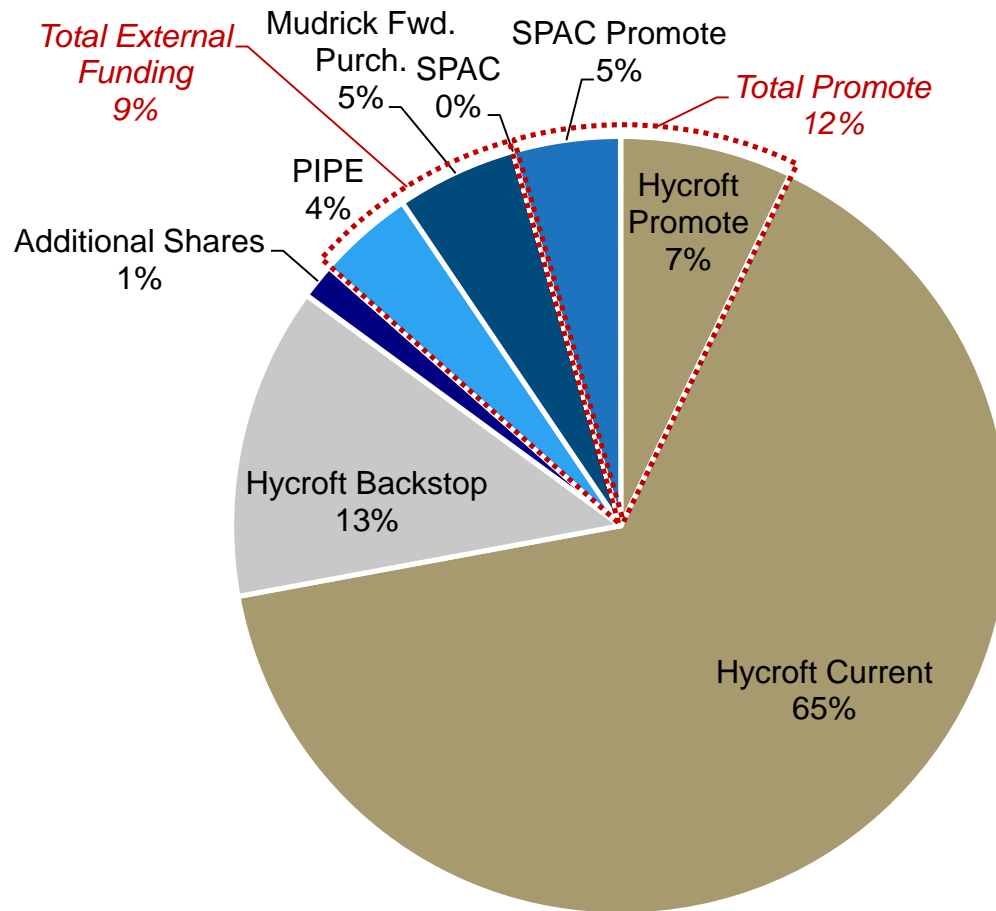

NAV Build-Up

Components	Build-Up
	(\$ mm)
Hycroft NPV ⁽²⁾	\$1,994
Pro Forma Debt:	
SRL Debt	(\$70)
New Note	(\$80)
Cash	\$65
LOM Discounted Corp. G&A ⁽³⁾	(\$121)
NAV	\$1,787
Implied P / NAV Mult.	0.28x

Source: Company filings, S-4

- Equity value assumed to be distributed pro rata amongst equity holders and equitized debt holders.
- Shown net of SRL royalty.
- Includes average annual G&A of \$7.5 mm over the 34 year mine life discounted at 5%.

Better Recoveries than Feasibility Study

Brimstone, Vortex, lower Camel Testing

Represents:

- 81% of total reserve ore tons
- 81% of total reserve Gold ounces
- 85% of total reserve Silver ounces

Recoveries:

- 82% and 91% vs Feasibility Study of 65%
- Rate of Oxidation 21% faster than Feasibility Study
 - 76 operating days per annum increase

Gold Produced:

- Using 80% recovery
 - +1.3M oz AU sold with no additional operating costs

Cell 1 Brimstone Recovery

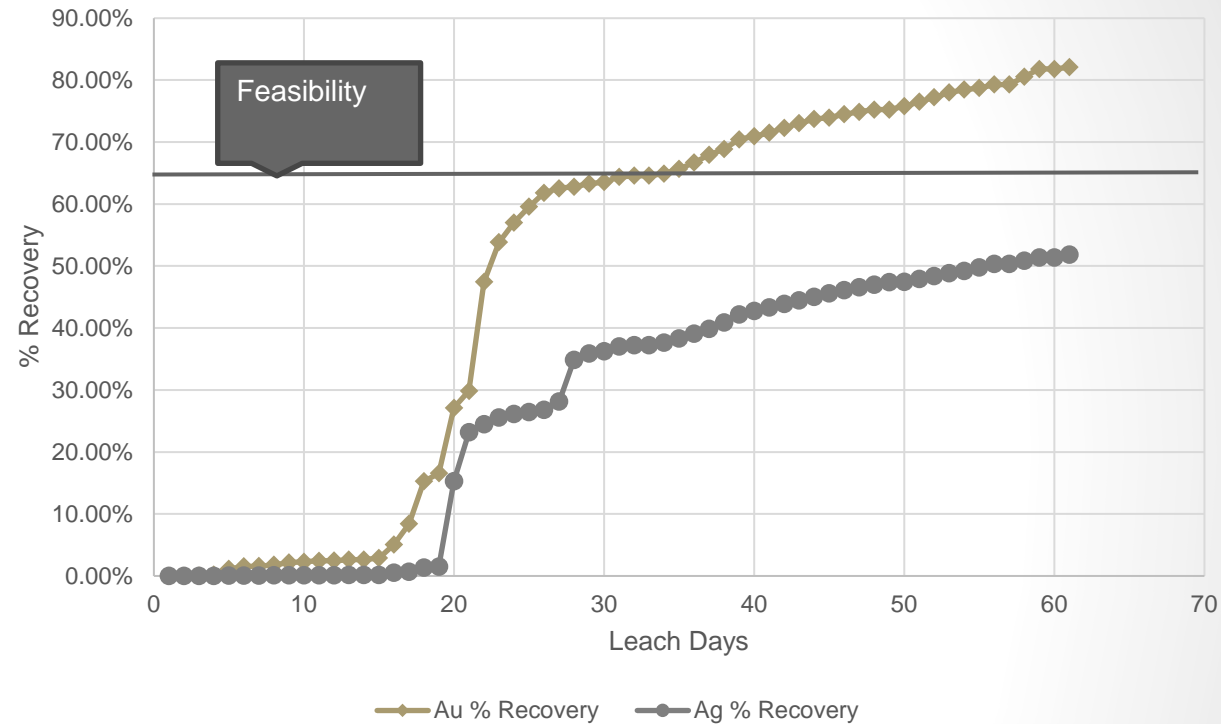

Source: Hycroft Mining Management

Note: March to October 2019 production data based on actuals.

Better Recoveries than Feasibility Study (cont'd)

Central, Cut 5

Represents:

- 19% of total reserve ore tons
- 18% of total reserve Gold ounces
- 14% of total reserve Silver ounces

Recoveries:

- 95% and 91% vs Feasibility Study of 70%
- Rate of Oxidation 21% faster than Feasibility Study
 - 76 operating days per annum increase

Gold Produced:

- Using 80% recovery
 - +0.4M oz AU sold with no additional operating costs

Cell 2 Central Recovery

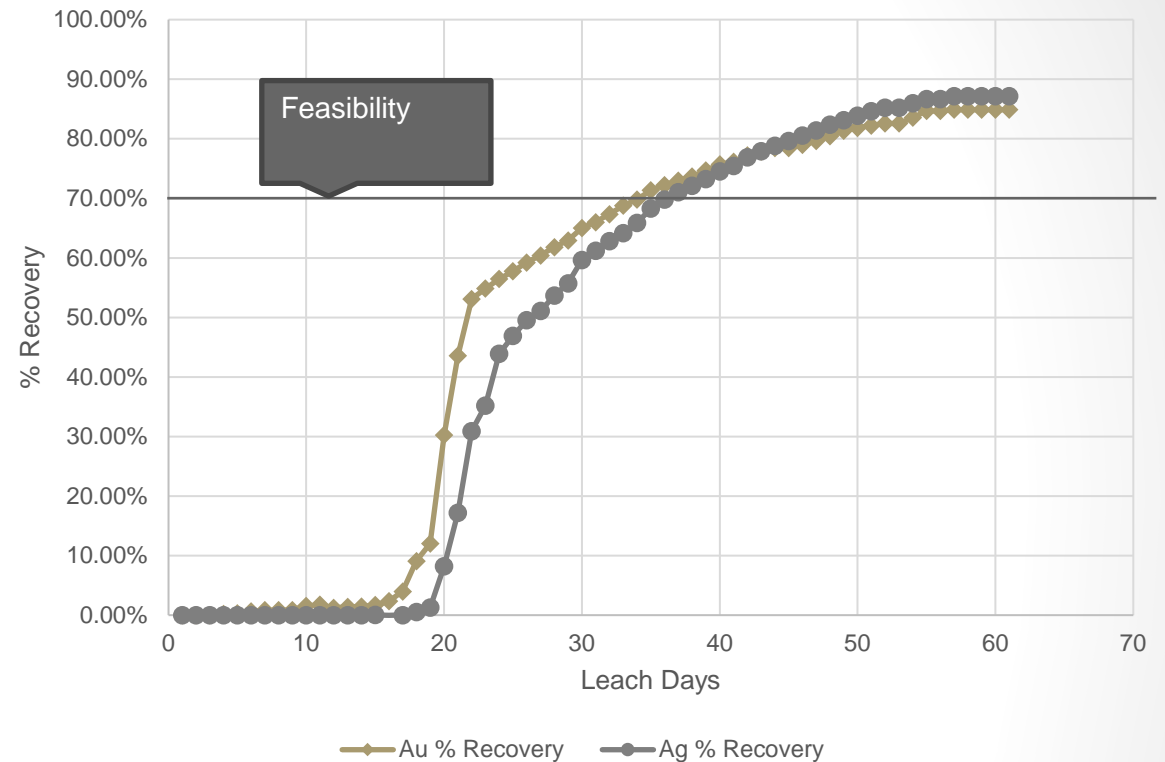

Financial Details (Feasibility Study)

Hycroft Mine Overview (1)

		Years 1-5	Years 1-10	LOM
Production AuEq	(koz)	908	2,812	12,433
By-Product Cash Costs ⁽³⁾	(\$ / oz)	\$775	\$626	\$472
AISC ⁽²⁾⁽³⁾	(\$ / oz)	\$775	\$766	\$548
Free Cash Flow ⁽³⁾	(\$ mm)	\$123	\$786	\$5,062
Capital	(\$ mm)	\$225	\$491	\$758

LOM Free Cash Flow – Cumulative (1,3)

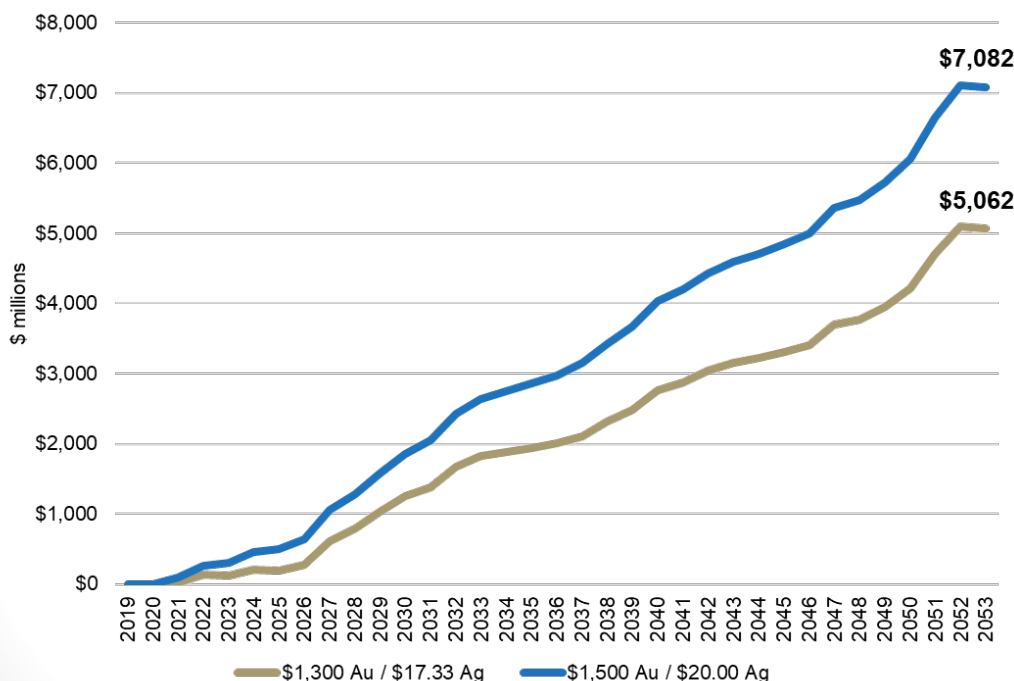

Source: Hycroft Mining Management, company filings

1. August 2019 Feasibility Study (effective date of July 31, 2019), using sales prices per ounce of \$1,300 Au / \$17.33 Ag, see “Cautionary Note Regarding Forward-Looking Statements” section.
2. AISC includes all cash outflows other than federal income tax and initial capex during first 5 years.
3. By-product cash costs, All-in Sustaining Costs (“AISC”), and Free Cash Flow are non-GAAP financial measures, see “Cautionary Note on Non-GAAP Financial Measures” section.

Feasibility Study Sensitivities (1)

	20% Decrease	10% Decrease	Base Case	10% Increase	20% Increase
Mining Cost	\$2.41B	\$2.24B	\$2.1B	\$1.91B	\$1.74B
Processing Cost	\$2.43B	\$2.26B		\$1.90B	\$1.71B
CapEx	\$2.18B	\$2.13B		\$2.03B	\$1.98B

- Mine plan economics resilient to small changes in mining and processing costs, due to the lower operating leverage
- Low sensitivity to capex, due to Hycroft’s capital light restart which leverages existing infrastructure

Case	Metal Prices (\$/oz.)		NPV @ 0% \$ Billions	NPV @ 5% \$ Billions	After Tax IRR %
	Au	Ag			
1	\$1,200	\$16.50	\$4.2	\$1.7	80%
2	\$1,300	\$17.33	\$5.1	\$2.1	148%
3	\$1,400	\$18.67	\$6.1	\$2.6	304%
4	\$1,500	\$20.00	\$7.1	\$3.0	n.a.
5	\$1,700	\$15.50	\$7.1	\$3.1	n.a.

1. Downside Price (Reserve Price)
2. Financial Base Case
3. Moderate Price
4. Upside Price
5. Current Price

- Significant upside above Feasibility Study metal prices

Production Schedule (Feasibility Study)

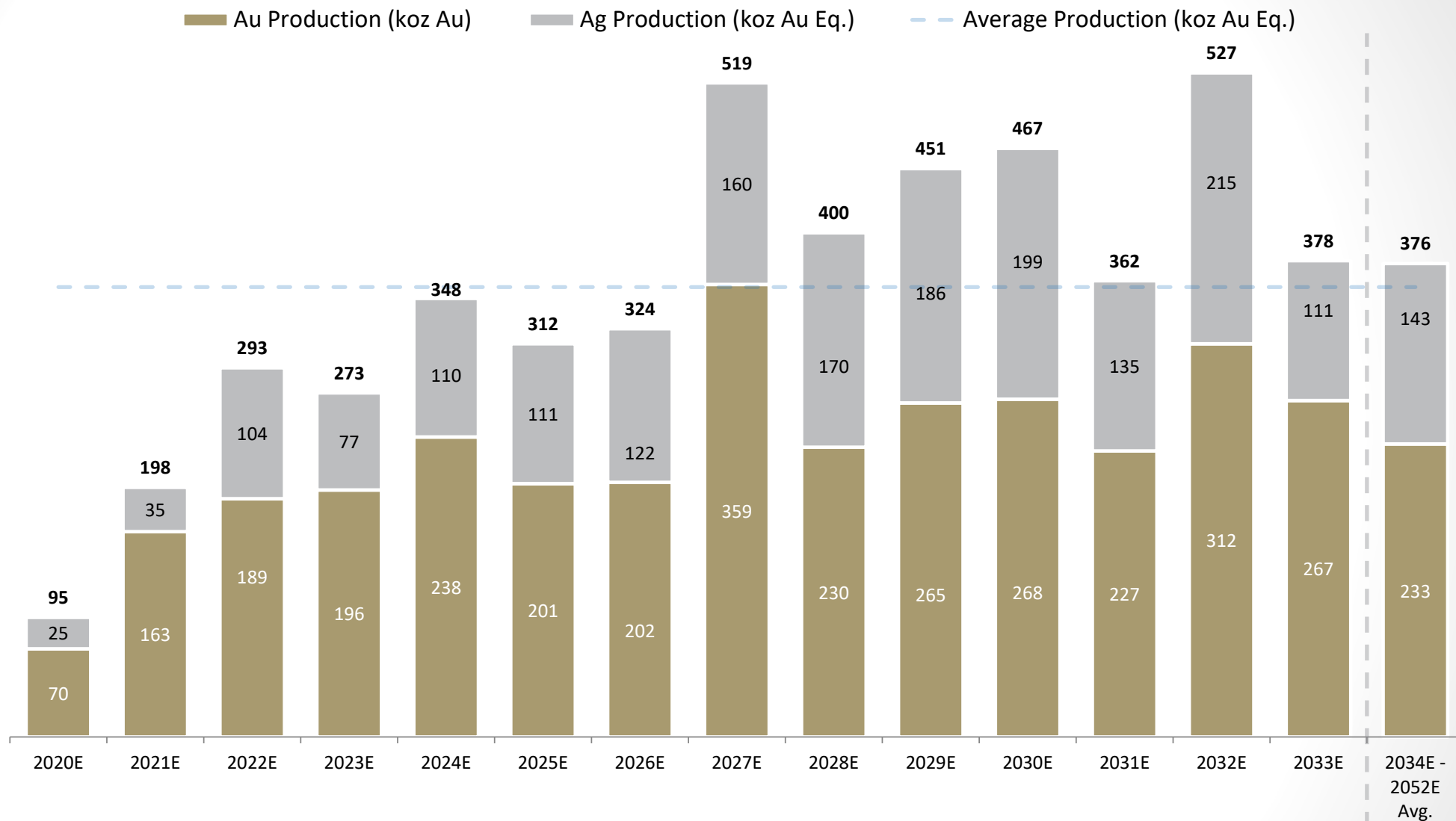

LIFE OF MINE — AVERAGE ANNUAL AU EQ. PRODUCTION OF ~366KOZ PER ANNUM

Source: August 2019 Feasibility Study (effective date of July 31, 2019)

Note: Gold equivalent production calculated assuming \$1,300/oz gold and \$17.33/oz silver; See "Cautionary Note Regarding Forward-Looking Statements."

Free Cash Flow (Feasibility Study)

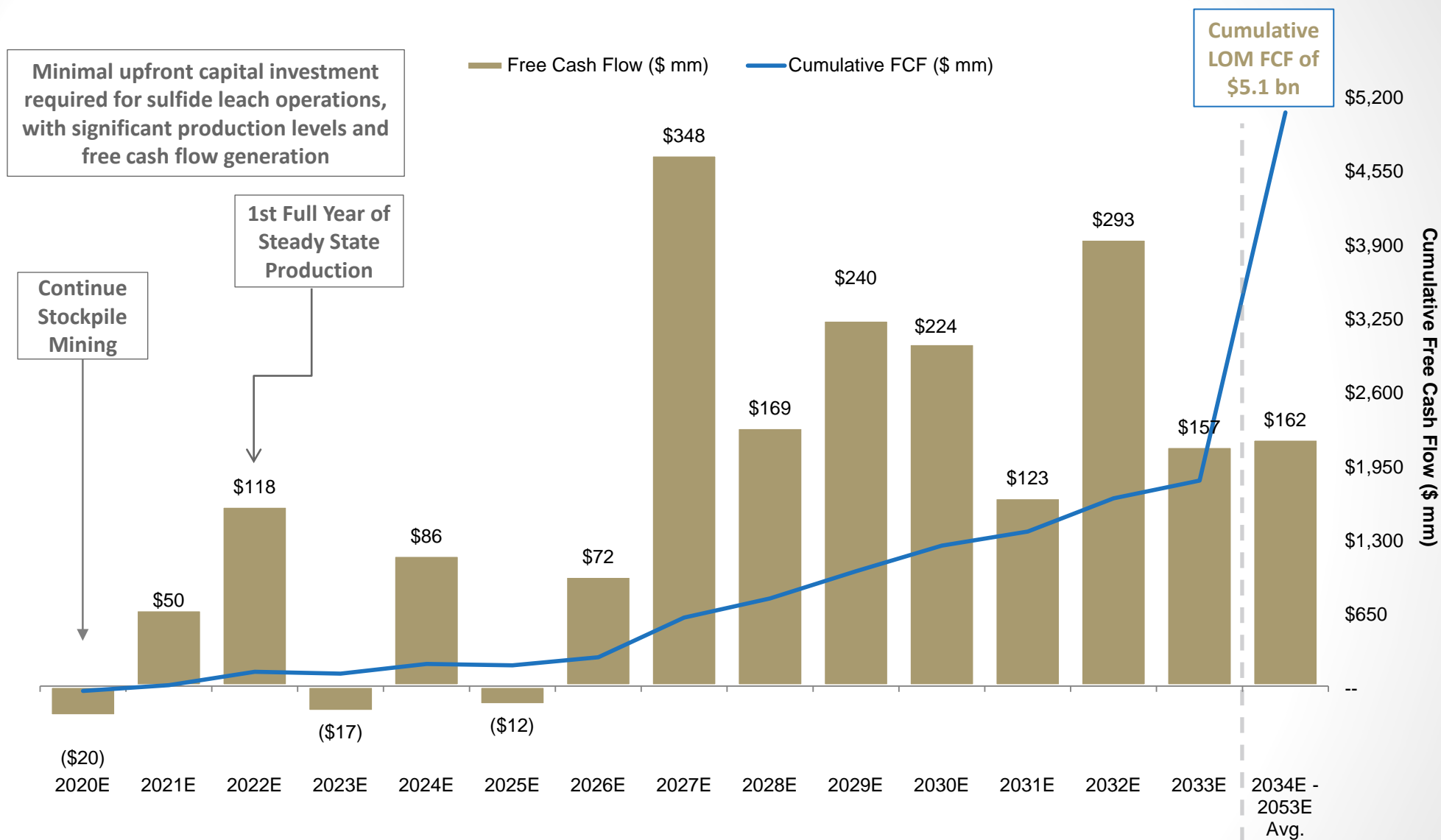

Source: August 2019 Feasibility Study (effective date of July 31, 2019)

Note: Free cash flow calculated assuming \$1,300/oz gold and \$17.33/oz silver; See "Cautionary Note Regarding Forward-Looking Statements."

Note: Free cash flow is a Non-GAAP Financial measures; see "Cautionary Note on Non-GAAP Financial Measures."

Ore Processing Commencing; Restart Completed



Leach pads required for ore processing are constructed

Crusher rebuild and commissioning completed

Mobile equipment fleet restarted and operating



Monthly Start-up Production Schedule – Ore Placed on Leach Pads

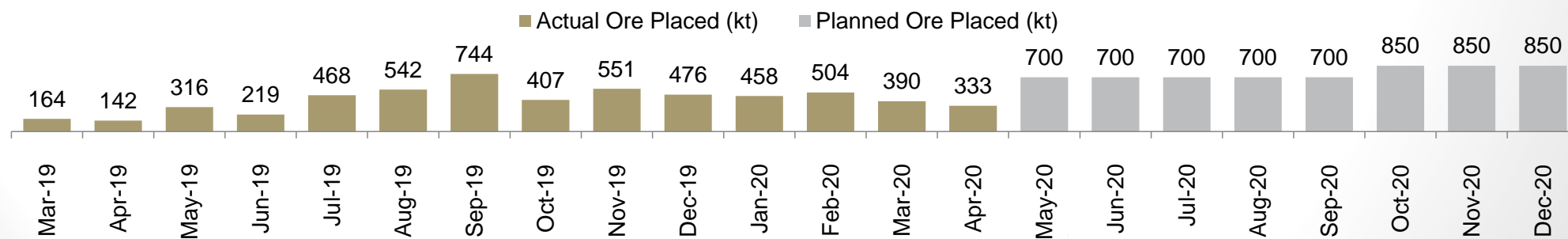

Source: Hycroft Mining Management

Mining

- Currently operating with owned fleet of six 200-ton haul trucks, two shovels, two loaders, and support equipment
- Supplemented with contractor fleet of one shovel, seven 240-ton haul trucks and one loader
- 24-hour mining operations
- Recently commenced active in-pit drill and blast



Source: Hycroft Mining Management

Processing



- The secondary and tertiary crushers were recommissioned and placed online in March 2019
- The primary crusher was reconditioned and brought into operation in late March 2019
- Sulfide material began being fed through the crushing system on start-up



Source: Hycroft Mining Management

Improved Heap Leach Recoveries Using Pre-Oxidation

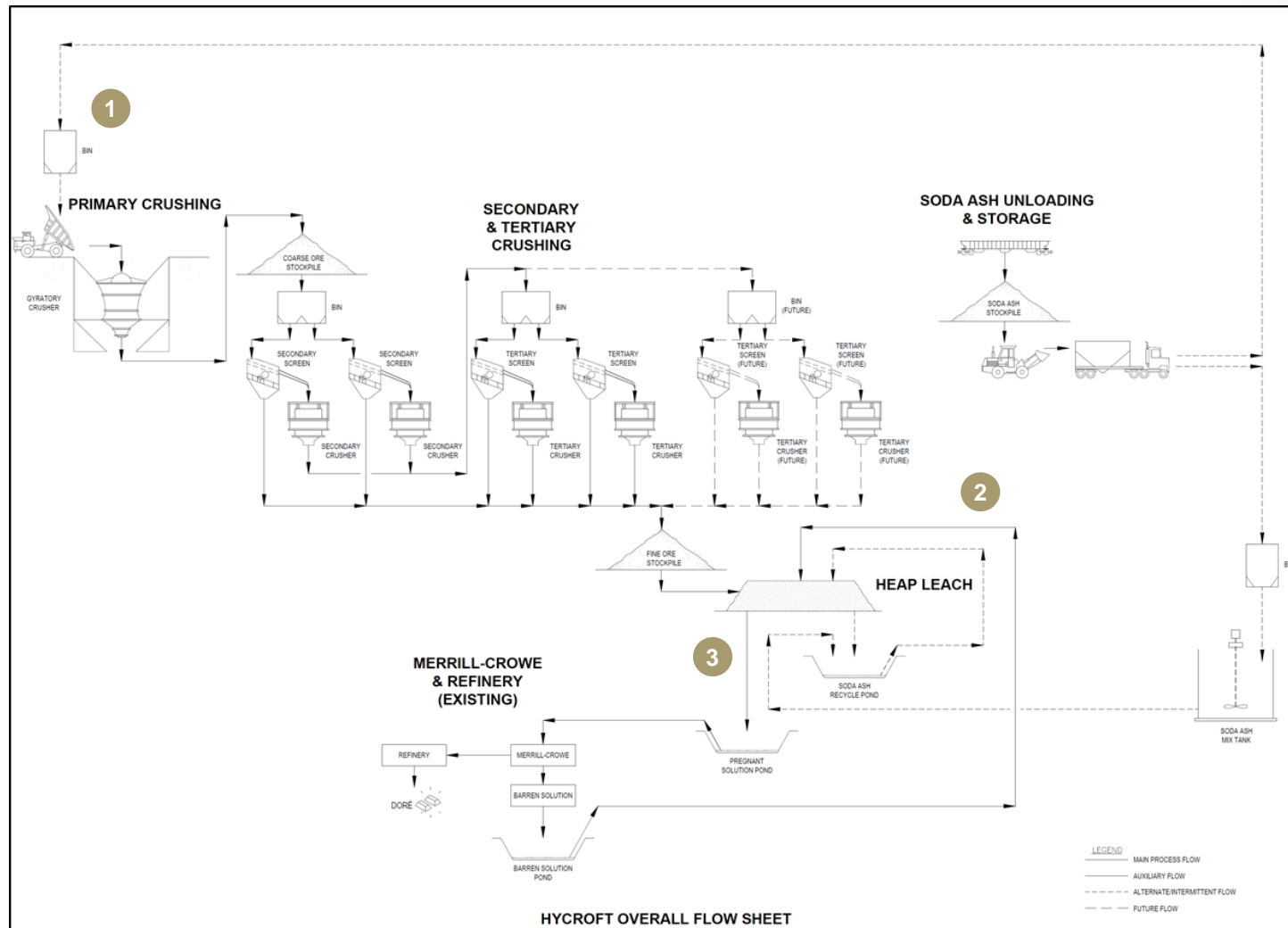

- 1 Soda Ash added to the ore prior to the primary crusher to create an environment (pH) conducive to the oxidation of Transition and Sulfide ore
- 2 Soda Ash solution added on a regular basis to Sulfide ore over the 60 to 120 day pre-oxidation period to offset evaporation and replenish carbonate consumption and maintain 8% to 10% moisture. Pads and oxidation are monitored with lysimeters which monitor oxygen, alkalinity, and other chemical levels. There are also different leach pad cells which allow the different ore domains to oxidize over different time intervals
- 3 Final rinse of lime solution to remove bicarbonate from the heap and prevent cyanide loss during leaching

Source: August 2019 Feasibility Study (effective date of July 31, 2019)

Oxidation Control

- Control of the oxidation process starts at the **crusher**; reagent dosing of material headed into the crusher using head assay data is the most important step in the process
- The **monitoring** system for the progress of the oxidation process continues to be refined. The instruments and lysimeters are working as intended
- **Solution** management to account for inclement weather conditions has been the most challenging aspect, but has not halted progress (before and after pictured)
- **Data** management for old pads continues to inform the way we approach present and future challenges
 - For example, pH trends observed in the first set of cells led to increased soda ash dosing at the crusher for later cells which has accelerated the oxidation cycle



Contingency Controls

- In occasions where solution-based monitoring of a panel is challenging, alternative methods are available and a standard practice to ensure goals are met
 - Each panel has a lab column built from the same bulk head sample run several weeks ahead of the pad. Lab columns are easily monitored and leading indicators of the pad behavior
 - Regular solid sampling of the pad material is performed so that changes to the cyanide-soluble gold can be directly monitored, and the relationship between oxidation and cyanide-soluble can be documented and used for decision making



Pad Construction and Loading



- Test Pads 1 to 3 finalized
- Produced gold from pads 4 to 8; second lift of 7 and 5 to produce in 2020
- Pad 9 to produce in 2020
- New leach pad construction in 2020 has begun



Capital-Light, Permitted Restart with Attractive Economics

Significant Milestones

- ✓ All substantial permits and rights necessary for re-start have been received
- ✓ Updated feasibility study
- ✓ Constructed initial leach pad
- ✓ Commenced ore processing
- ✓ First gold sold

Initial Capital Expenditure Plan⁽¹⁾

(\$ 000's)	Years 1-5	Year 1	Year 2	Year 3	Year 4	Year 5
Leach Pad & Pond Construction	\$50,831	\$31,951	\$18,425	--	\$455	--
Mobile Equipment	\$312	--	\$312	--	--	--
M3 Capital:						
General	\$4,595	--	--	\$4,595	--	--
Primary Crushing	\$400	--	--	\$400	--	--
Secondary & Tertiary Crushing	\$42,202	--	--	\$10,350	\$9,459	\$22,393
Conveying & Stacking	\$55,596	--	--	\$15,778	\$3,506	\$36,311
Reagents	\$19,016	--	--	--	--	\$19,016
Rail Unloading & Storage	\$33,773	--	--	--	\$10,792	\$22,981
De-watering	\$10,401	--	\$3,850	\$376	\$2,385	\$3,791
Owner's Team	\$5,148	\$4,548	\$600	--	--	--
Other Annual Sustaining	\$2,500	\$500	\$500	\$500	\$500	\$500
Total	\$224,774	\$36,999	\$23,687	\$32,000	\$27,097	\$104,991

Initial capital costs of \$61 mm

Source: August 2019 Feasibility Study (effective date of July 31, 2019), Street research

1. Based on August 2019 Feasibility Study (effective date of July 31, 2019), see "Cautionary Note Regarding Forward-Looking Statements" section.
2. NPV and Capex taken from feasibility reports for the respective companies.

Initial 5-year Capex Summary⁽¹⁾

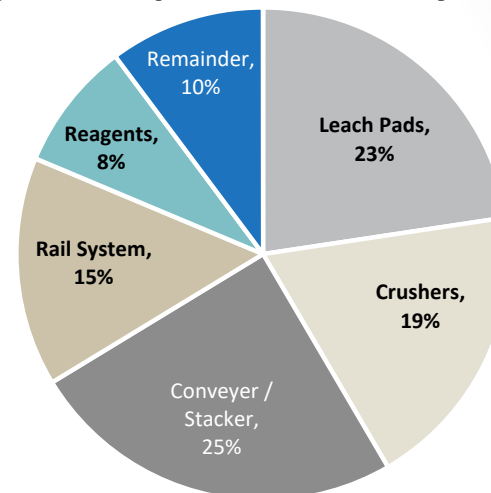

Feasibility Capex % of Project NPV (%)^(1,2)

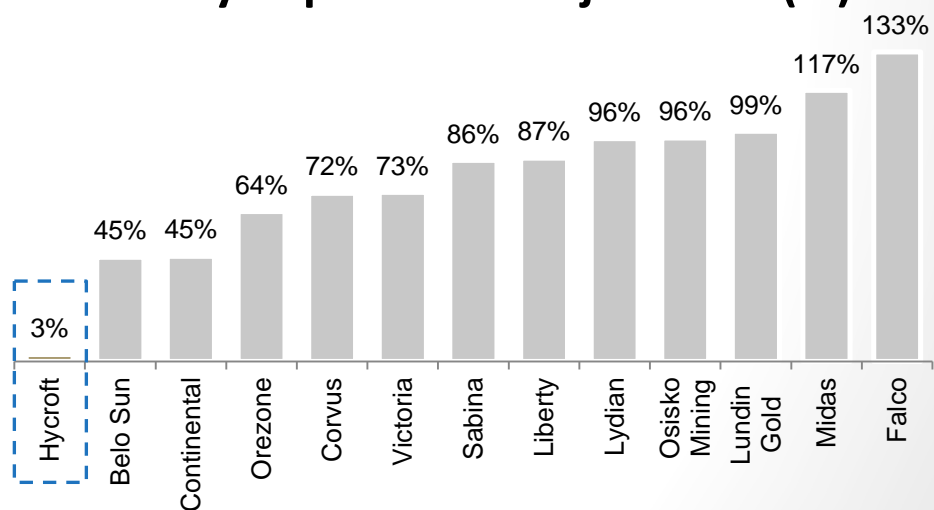

- \$61M of initial capex during years 1-2 = 3% of project NPV
- \$225M of capex during years 1 to 5 to get to higher FS production levels = 11% of project NPV

Significant Infrastructure on Site

Significant Equipment and Infrastructure on Site

- Since 2011, more than \$400 mm already spent in anticipation of mine expansion
- Existing leach pads have approximately 30 mm tons of capacity
- 2 Merrill-Crowe plants (26,000 gpm capacity), carbon columns (6,000 gpm) and 1 refinery
- Equipment for second refinery acquired and on site
- Powerline and water supply in place
- 3-stage crushing system was installed in 2014
 - System re-commissioning is nearly complete
- Administrative buildings, truck shop, and support facilities are built

Capital Spent to Date (\$ mm)

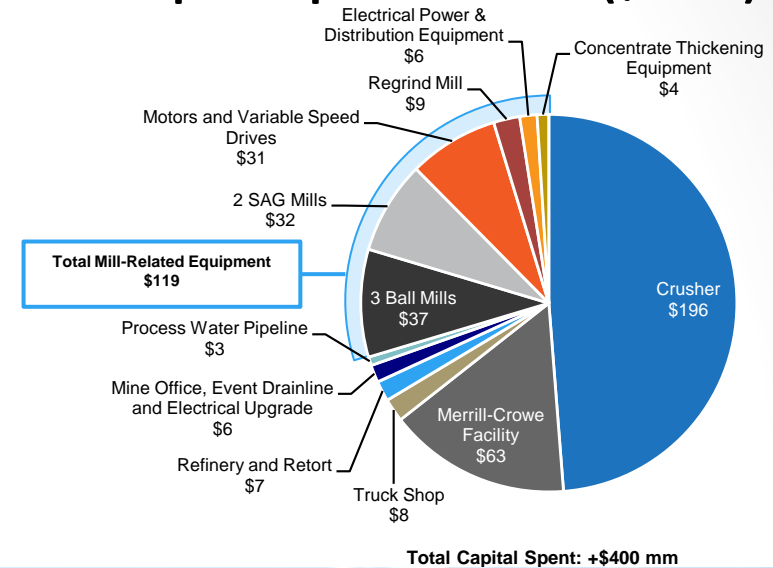

Source: Hycroft Mining Management

Cautionary Note to U.S. Investors Regarding Reserves and Resources

The Mineral Resource and Mineral Reserve estimates contained in this presentation have been prepared in accordance with the requirements of the Modernization of Property Disclosures for Mining Registrants (the “New Mining Rules”) set forth in subpart 1300 of Regulation S-K, as promulgated by the United States Securities and Exchange Commission (“SEC”). These disclosures differ in material respects from the requirements set forth in Industry Guide 7, which remains applicable to U.S. companies subject to the reporting and disclosure requirements of the SEC that have not early adopted the New Mining Rules. These standards differ significantly from the disclosure requirements of Industry Guide 7 in that mineral resource information contained herein may not be comparable to similar information disclosed by U.S. companies that have not early adopted the New Mining Rules promulgated by the SEC.

Under SEC standards, mineralization, such as mineral resources, may not be classified as a “reserve” unless the determination has been made that the mineralization could be economically and legally produce or extracted at the time of the reserve determination. The term “economically,” as used in the SEC’s Industry Guide 7 definition of reserves, means that profitable extraction or production has been established or analytically demonstrated in a feasibility study to be viable and justifiable under reasonable investment and market assumptions. The term “legally” as used in the SEC’s Industry Guide 7 definition of reserves, does not imply that all permits needed for mining and processing have been obtained or that other legal issues have been completely resolved. However, for a reserve to exist, we must have a justifiable expectation, based on applicable laws and regulations, that issuance of permits or resolution of legal issues necessary for mining and processing at a particular deposit will be accomplished in the ordinary course and in a timeframe consistent with our current mine plans. As used in this joint proxy statement/prospectus, the terms “mineral resource”, “measured mineral resource”, “indicated mineral resource” and “inferred mineral resource” are defined and used in accordance with the New Mining Rules set forth in subpart 1300 of Regulation S-K, even though such terms are not recognized under Industry Guide 7 which the New Mining Rules will replace beginning January 1, 2021 for companies that do not early adopt the New Mining Rules. You are specifically cautioned not to assume that any part or all of the mineral deposits in these categories will ever be converted into mineral reserves, as defined by the SEC.

You are cautioned that, except for that portion of mineral resources classified as mineral reserves, mineral resources do not have demonstrated economic value. Inferred mineral resources have a high degree of uncertainty as to their existence as to whether they can be economically or legally mined. Under the New Mining Rules, estimates of inferred mineral resources may not form the basis of an economic analysis. It cannot be assumed that all or any part of an inferred mineral resource will ever be upgraded to a higher category. A significant amount of exploration must be completed in order to determine whether an inferred mineral resource may be upgraded to a higher category. Therefore, you are cautioned not to assume that all or any part of an inferred mineral resource exists, that it can be economically or legally mined, or that it will ever be upgraded to a higher category. Likewise, you are cautioned not to assume that all or any part of measured or indicated mineral resources will ever be upgraded to mineral reserves.

Cautionary Note on Non-GAAP Financial Measures

This Presentation has not been prepared in accordance with, and does not contain all of the information that is required by, the rules and regulations of the SEC. Certain financial measures, including AISC, By-Product Cash Costs and Free Cash Flow and the related pro-forma information presented in this presentation are supplemental measures of our performance, liquidity and ability to service debt are not required by, or presented in accordance with, generally accepted accounting principles in the United States (“GAAP”). Such measures are not measurements of our financial performance under GAAP and should not be considered as an alternative to net income, operating income or any other performance measures derived in accordance with GAAP or as an alternative to cash flows from operating activities as a measure of our liquidity.

Non-GAAP Measure - AISC

All-in Sustaining Costs (“AISC”) include total production cash costs to be incurred at Seller’s mining operation, plus sustaining capital expenditures (once the initial capital is spent) and reclamation costs, less revenue generated from silver sales. Additionally, the measure seeks to reflect the full cost of gold production from our operations, therefore initial expansionary capital is excluded. Certain other cash expenditures, including income tax payments and financing costs are also excluded.

We believe that this measure represents the total costs of producing gold from current operations and provides us and other stakeholders with additional information of our operational performance and ability to generate cash flows. AISC, as a key performance measure, allows us to assess its ability to support capital expenditures and to sustain future production from the generation of operating cash flows. This information provides management with the ability to more actively manage capital programs and to make more prudent capital investment decisions.

We calculate AISC on a gold ounces sold basis, where silver revenue is treated as a reduction in operating costs. This performance measure was adopted as a result of an initiative undertaken within the gold mining industry; however, this performance measure has no standardized meaning and should not be considered in isolation or as a substitute for measures of performance prepared in accordance with GAAP. Seller follows the guidance note released by the World Gold Council, which became effective January 1, 2014, in calculating AISC. The World Gold Council is a non-regulatory market development organization for the gold industry whose members comprise global senior gold mining companies.

Non-GAAP Measure – By-Product Cash Costs

By-Product Cash Costs incorporate our share of all production costs, including adjustments to inventory carrying values, adjusted for changes in estimates in reclamation and closure costs at the Company’s mines which are non-cash in nature, and include by-product silver credits, and treatment and refining charges included within revenue. Additionally, cash costs are adjusted for realized gains and losses arising on the Company’s commodity and foreign currency contracts which the Company may enter into to mitigate its exposure to fluctuations in by-product metal prices, heating oil prices and foreign exchange rates, which may impact the Company’s operating costs.

In addition to conventional measures, we assess this per ounce measure in a manner that isolates the impacts of gold production volumes, the by-product credits, and operating costs fluctuations such that the non-controllable and controllable variability is independently addressed. We use total cash costs: by-product per gold ounce to monitor our operating performance internally, including operating cash costs, as well as in our assessment of potential development projects and acquisition targets. We believe this measure provides investors and analysts with useful information about our underlying cash costs of operations and the impact of by-product credits on our cost structure and is a relevant metric used to understand our operating profitability and ability to generate cash flow. When deriving the production costs associated with an ounce of gold, we include by-product credits as we consider that the cost to produce the gold is reduced as a result of the by-product sales incidental to the gold production process, thereby allowing management and other stakeholders to assess the net costs of gold production.

We report by-product cash costs on a gold ounces sold basis. In the gold mining industry, this is a common performance measure but does not have any standardized meaning. We follow the recommendations of the Gold Institute Production Cost Standard. The Gold Institute, which ceased operations in 2002, was a non-regulatory body and represented a global group of producers of gold and gold products. The production cost standard developed by the Gold Institute remains the generally accepted standard of reporting cash costs of production by gold mining companies.

Free Cash Flow

Unlevered free cash flow is a non-GAAP financial measure that presents our ability to service debt and is determined by reducing our after-tax cash flow provided by operating activities by maintenance capital expenditures. Projections of unlevered free cash flow are not based on GAAP net income/loss or cash flow provided by operating activities, respectively, and are anticipated to be adjusted to exclude the effects of events or circumstances over the periods presented that are not representative or indicative of results of operations and that are not currently determinable. Due to the startup nature of current operations and the uncertainty of the likelihood, amount and timing of any such adjusting items, we do not have information available, without undertaking unreasonable efforts, to provide a quantitative reconciliation of any projected non-GAAP financial measures at this time.

Reconciliations

Our projections of AISC, By-Product Cash Costs and Free Cash Flow are not based on GAAP net income/loss or Cash flow provided by operating activities, respectively. As the Company has not reached commercial production and the uncertainty of the likelihood, we do not have information available, to provide a quantitative reconciliation of any projected non-GAAP financial measures at this time and are unable to provide such information without unreasonable effort.