

# Gold Bar Project



## S-K 1300 Technical Report Summary Feasibility Study Eureka County, Nevada

Authors:

M3 Engineering & Technology Corporation

Gingerquill Consulting LLC

IMC

Forte Dynamics

Prepared For:



GOLD BAR PROJECT  
FORM S-K 1300 TECHNICAL REPORT SUMMARY

TABLE OF CONTENTS

| SECTION   | PAGE      |
|---|-----------|
| TABLE OF CONTENTS.....  | I         |
| LIST OF FIGURES AND ILLUSTRATIONS.....                            | VII       |
| LIST OF TABLES.....   | XI        |
| <b>1 EXECUTIVE SUMMARY.....</b>                                   | <b>1</b>  |
| <b>III KEY RESULTS.....</b>                                       | <b>1</b>  |
| <b>1.2 ECONOMIC ANALYSIS .....</b>                                | <b>1</b>  |
| <b>1.3 PROPERTY DESCRIPTION AND OWNERSHIP .....</b>               | <b>2</b>  |
| <b>1.4 GEOLOGY AND MINERALIZATION.....</b>                        | <b>2</b>  |
| <b>1.5 EXPLORATION.....</b>                                       | <b>3</b>  |
| <b>1.6 METALLURGICAL TESTING AND PROCESS DESIGN CRITERIA.....</b> | <b>4</b>  |
| <b>1.7 MINERAL RESOURCE ESTIMATE.....</b>                         | <b>5</b>  |
| <b>1.8 MINERAL RESERVE ESTIMATE.....</b>                          | <b>7</b>  |
| <b>1.9 MINING METHODS.....</b>                                    | <b>8</b>  |
| <b>1.10 MINERAL PROCESSING AND RECOVERY METHODS.....</b>          | <b>11</b> |
| <b>1.11 PROJECT INFRASTRUCTURE.....</b>                           | <b>12</b> |
| <b>1.12 ENVIRONMENTAL STUDIES AND PERMITTING.....</b>             | <b>12</b> |
| <b>1.13 CAPITAL AND OPERATING COSTS .....</b>                     | <b>12</b> |
| <b>2 INTRODUCTION .....</b>                                       | <b>14</b> |
| <b>2.1 DETAILS OF REGISTRANT.....</b>                             | <b>14</b> |
| <b>2.2 UNITS OF MEASURE.....</b>                                  | <b>14</b> |
| <b>2.3 TERMS OF REFERENCE .....</b>                               | <b>14</b> |
| <b>2.4 CAUTIONARY STATEMENTS.....</b>                             | <b>16</b> |
| <b>2.5 SOURCE OF INFORMATION .....</b>                            | <b>17</b> |
| <b>2.6 QP DETAILS AND SITE VISIT .....</b>                        | <b>17</b> |
| <b>3 PROPERTY DESCRIPTION AND OWNERSHIP.....</b>                  | <b>19</b> |
| <b>3.1 PROPERTY LOCATION.....</b>                                 | <b>19</b> |
| <b>3.2 MINERAL TITLES .....</b>                                   | <b>21</b> |
| <b>3.3 ROYALTIES, AGREEMENTS AND ENCUMBRANCES .....</b>           | <b>26</b> |
| <b>3.4 ENVIRONMENTAL LIABILITIES AND PERMITTING.....</b>          | <b>28</b> |
| <b>3.5 OTHER SIGNIFICANT FACTORS AND RISKS.....</b>               | <b>29</b> |

|          |  |           |
|----------|--|-----------|
| <b>4</b> | <b>ACCESSIBILITY, CLIMATE, LOCAL RESOURCES, INFRASTRUCTURE AND PHYSIOGRAPHY.....</b> | <b>30</b> |
| 4.1      | TOPOGRAPHY, ELEVATION AND VEGETATION.....  | 30        |
| 4.2      | ACCESSIBILITY AND TRANSPORTATION TO THE PROPERTY.....                                | 30        |
| 4.3      | CLIMATE AND LENGTH OF OPERATING SEASON.....  | 32        |
| 4.4      | SUFFICIENCY OF SURFACE RIGHTS.....   | 32        |
| 4.5      | INFRASTRUCTURE AVAILABILITY AND SOURCES.....   | 32        |
| <b>5</b> | <b>HISTORY.....</b>  | <b>34</b> |
| 5.1      | PRIOR OWNERSHIP AND OWNERSHIP CHANGES.....   | 34        |
| 5.2      | EXPLORATION AND DEVELOPMENT RESULTS OF PREVIOUS OWNERS.....                          | 34        |
| 5.3      | HISTORICAL MINERAL RESOURCE AND RESERVE ESTIMATES.....                               | 38        |
| 5.4      | HISTORICAL PRODUCTION GBN AND GBS.....   | 56        |
| <b>6</b> | <b>GEOLOGICAL SETTING, MINERALIZATION, AND DEPOSIT.....</b>                          | <b>57</b> |
| 6.1      | REGIONAL GEOLOGY.....  | 57        |
| 6.2      | LOCAL AND PROPERTY GEOLOGY.....  | 57        |
| 6.3      | STRUCTURAL GEOLOGY.....  | 60        |
| 6.4      | SIGNIFICANT MINERALIZED ZONES.....   | 66        |
| 6.5      | DEPOSIT TYPES.....   | 69        |
| 6.6      | GOLD BAR NORTH.....  | 70        |
| 6.7      | GOLD BAR SOUTH.....  | 71        |
| 6.8      | DESCRIPTIONS OF MINERALIZATION.....  | 71        |
| <b>7</b> | <b>EXPLORATION.....</b>  | <b>73</b> |
| 7.1      | GEOCHEMICAL EXPLORATION.....   | 74        |
| 7.2      | GEOLOGIC MAPPING.....  | 75        |
| 7.3      | GEOPHYSICAL EXPLORATION.....   | 75        |
| 7.4      | SPECTRAL EXPLORATION.....  | 76        |
| 7.5      | UNDERGROUND EXPLORATION.....   | 76        |
| 7.6      | DRILLING.....  | 88        |
| 7.7      | TYPE AND EXTENT.....   | 88        |
| 7.8      | PROCEDURES.....  | 97        |
| 7.9      | INTERPRETATION AND RELEVANT RESULTS.....   | 98        |
| <b>8</b> | <b>SAMPLE PREPARATION, ANALYSES AND SECURITY.....</b>                                | <b>99</b> |
| 8.1      | SAMPLING AND SECURITY MEASURES.....  | 99        |
| 8.2      | SAMPLE PREPARATION FOR ANALYSIS.....   | 99        |
| 8.3      | SAMPLE ANALYSIS.....   | 100       |

**GOLD BAR PROJECT**  
**S-K 1300 TECHNICAL REPORT SUMMARY**

---

|           |  |            |
|-----------|--|------------|
| 8.4       | QUALITY ASSURANCE/QUALITY CONTROL PROCEDURES.....                                | 101        |
| 8.5       | OPINION ON ADEQUACY.....   | 115        |
| <b>9</b>  | <b>DATA VERIFICATION.....</b>  | <b>117</b> |
| 9.1       | PROCEDURES.....  | 117        |
| 9.2       | LIMITATIONS.....   | 118        |
| 9.3       | OPINION ON DATA ADEQUACY .....   | 118        |
| <b>10</b> | <b>MINERAL PROCESSING AND METALLURGICAL TESTING .....</b>                        | <b>119</b> |
| 10.1      | INTRODUCTION.....  | 119        |
| 10.2      | GOLD BAR NORTH – UPDATED PRECIOUS METAL RECOVERY AND RECOVERY RATE ANALYSIS..... | 120        |
| 10.3      | GOLD BAR NORTH – BASIS OF KEY PROCESS DESIGN CRITERIA .....                      | 125        |
| 10.4      | GOLD BAR SOUTH.....  | 126        |
| <b>11</b> | <b>MINERAL RESOURCE ESTIMATES .....</b>  | <b>128</b> |
| 11.1      | INTRODUCTION – QUALIFIED PERSONS.....  | 128        |
| 11.2      | GOLD PICK BLOCK MODEL.....   | 128        |
| 11.3      | GOLD PICK ASSAY DATA POPULATION DOMAIN ANALYSIS AND CAPPING .....                | 129        |
| 11.4      | GOLD PICK COMPOSITING.....   | 130        |
| 11.5      | GOLD PICK GEOMETALLURGICAL MODELING.....   | 131        |
| 11.6      | GOLD PICK HISTORIC MINING DUMPS .....  | 133        |
| 11.7      | GOLD PICK DENSITY.....   | 133        |
| 11.8      | GOLD PICK VARIOGRAPHY AND INTERPOLATION SEARCH CRITERIA.....                     | 134        |
| 11.9      | GOLD PICK GRADE ESTIMATION .....   | 137        |
| 11.10     | GOLD PICK MINERAL RESOURCE CLASSIFICATION.....                                   | 138        |
| 11.11     | GOLD PICK BLOCK MODEL VALIDATION.....  | 139        |
| 11.12     | GOLD PICK ECONOMIC INPUT PARAMETERS .....  | 146        |
| 11.13     | GOLD PICK RESOURCE SENSITIVITY .....   | 146        |
| 11.14     | GOLD RIDGE ASSAY DATA POPULATION DOMAIN ANALYSIS AND CAPPING.....                | 147        |
| 11.15     | GOLD RIDGE COMPOSITING .....   | 148        |
| 11.16     | GOLD RIDGE GEOMETALLURGICAL MODELING.....  | 150        |
| 11.17     | GOLD RIDGE HISTORIC MINING DUMPS.....  | 150        |
| 11.18     | GOLD RIDGE DENSITY .....   | 150        |
| 11.19     | GOLD RIDGE VARIOGRAPHY AND INTERPOLATION SEARCH CRITERIA .....                   | 150        |
| 11.20     | GOLD RIDGE GRADE ESTIMATION .....  | 154        |
| 11.21     | GOLD RIDGE MINERAL RESOURCE CLASSIFICATION .....                                 | 155        |
| 11.22     | GOLD RIDGE BLOCK MODEL VALIDATION .....  | 156        |

**GOLD BAR PROJECT**  
**S-K 1300 TECHNICAL REPORT SUMMARY**

---

|           |  |            |
|-----------|--|------------|
| 11.23     | GOLD RIDGE ECONOMIC INPUT PARAMETERS.....                              | 160        |
| 11.24     | GOLD RIDGE MINERAL RESOURCE SENSITIVITY.....                           | 160        |
| 11.25     | CABIN ASSAY DATA POPULATION DOMAIN ANALYSIS AND CAPPING.....           | 161        |
| 11.26     | CABIN COMPOSITING.....   | 162        |
| 11.27     | CABIN GEOMETALLURGICAL MODELING.....                                   | 164        |
| 11.28     | CABIN DENSITY .....  | 164        |
| 11.29     | CABIN VARIOGRAPHY AND INTERPOLATION SEARCH CRITERIA .....              | 164        |
| 11.30     | CABIN GRADE ESTIMATION.....  | 167        |
| 11.31     | CABIN MINERAL RESOURCE CLASSIFICATION .....                            | 168        |
| 11.32     | CABIN BLOCK MODEL VALIDATION .....                                     | 169        |
| 11.33     | CABIN CHANGE OF SUPPORT ANALYSIS .....                                 | 172        |
| 11.34     | CABIN ECONOMIC INPUT PARAMETERS.....                                   | 175        |
| 11.35     | CABIN MINERAL RESOURCE SENSITIVITY.....                                | 176        |
| 11.36     | GOLD BAR SOUTH ASSAY DATA POPULATION DOMAIN ANALYSIS AND CAPPING ..... | 177        |
| 11.37     | GOLD BAR SOUTH COMPOSTING .....  | 178        |
| 11.38     | GOLD BAR SOUTH GEOMETALLURGICAL MODELING.....                          | 179        |
| 11.39     | GOLD BAR SOUTH HISTORIC MINING DUMPS .....                             | 179        |
| 11.40     | GOLD BAR SOUTH DENSITY.....  | 179        |
| 11.41     | GOLD BAR SOUTH VARIOGRAPHY AND INTERPOLATION SEARCH CRITERIA.....      | 180        |
| 11.42     | GOLD BAR SOUTH GRADE ESTIMATION .....                                  | 183        |
| 11.43     | GOLD BAR SOUTH MINERAL RESOURCE CLASSIFICATION.....                    | 183        |
| 11.44     | GOLD BAR SOUTH BLOCK MODEL VALIDATION .....                            | 184        |
| 11.45     | GOLD BAR SOUTH ECONOMIC INPUT PARAMETERS .....                         | 188        |
| 11.46     | GOLD BAR SOUTH MINERAL RESOURCE SENSITIVITY .....                      | 188        |
| 11.47     | MINERAL RESOURCE STATEMENT.....  | 189        |
| 11.48     | POTENTIAL RISKS IN DEVELOPING THE MINERAL RESOURCE .....               | 190        |
| <b>12</b> | <b>MINERAL RESERVE ESTIMATES .....</b>                                 | <b>192</b> |
| 12.1      | RESERVE ESTIMATION .....   | 192        |
| 12.2      | RESERVE ESTIMATE .....   | 199        |
| 12.3      | CLASSIFICATION OF RESERVES.....  | 200        |
| 12.4      | RESERVE ESTIMATE RISKS .....   | 202        |
| <b>13</b> | <b>MINING METHODS.....</b>   | <b>203</b> |
| 13.1      | PRE-PRODUCTION AND MINE DEVELOPMENT .....                              | 205        |
| 13.2      | PHASE DESIGN .....   | 205        |

**GOLD BAR PROJECT  
S-K 1300 TECHNICAL REPORT SUMMARY**

---

|      |   |     |
|------|---|-----|
| 13.3 | MINE PRODUCTION SCHEDULE.....   | 207 |
| 13.4 | WASTE ROCK STORAGE DESIGN .....   | 207 |
| 13.5 | MINE EQUIPMENT REQUIREMENTS .....   | 209 |
| 13.6 | MANPOWER REQUIREMENTS.....  | 210 |
| 13.7 | PERIOD DRAWINGS.....  | 213 |
| 14   | PROCESSING AND RECOVERY METHODS .....   | 214 |
| 14.1 | PROCESS FLOW SHEET .....  | 214 |
| 14.2 | CRUSHING, AGGLOMERATING AND STACKING.....   | 216 |
| 14.3 | HEAP LEACH PAD DESIGN .....   | 217 |
| 14.4 | PROCESSING PLANT DESIGN AND OPERATIONS.....   | 218 |
| 14.5 | CONSUMABLE REQUIREMENTS .....   | 220 |
| 15   | INFRASTRUCTURE.....   | 222 |
| 15.1 | SITE ACCESS.....  | 222 |
| 15.2 | SERVICE ROADS.....  | 224 |
| 15.3 | PROCESS FACILITIES .....  | 224 |
| 15.4 | ANCILLARY FACILITIES.....   | 227 |
| 15.5 | SEPTIC SYSTEMS.....   | 227 |
| 15.6 | POWER SUPPLY AND DISTRIBUTION.....  | 227 |
| 15.7 | WATER SUPPLY.....   | 227 |
| 16   | MARKET STUDIES.....   | 229 |
| 16.1 | GOLD MARKETS AND DEMAND.....  | 229 |
| 16.2 | METAL PRICE .....   | 229 |
| 17   | ENVIRONMENTAL STUDIES, PERMITTING AND PLANS, NEGOTIATIONS, OR AGREEMENTS<br>WITH LOCAL INDIVIDUALS OR GROUPS..... | 230 |
| 17.1 | REQUIRED PERMITS AND STATUS .....   | 230 |
| 17.2 | ENVIRONMENTAL ISSUES .....  | 233 |
| 17.3 | SOCIAL AND COMMUNITY ISSUES.....  | 234 |
| 17.4 | CONCLUSIONS.....  | 235 |
| 18   | CAPITAL AND OPERATING COSTS .....   | 236 |
| 18.1 | INTRODUCTION.....   | 236 |
| 18.2 | OPERATING COSTS.....  | 236 |
| 18.3 | MINING COSTS.....   | 236 |
| 19   | ECONOMIC ANALYSIS.....  | 238 |
| 19.1 | INTRODUCTION.....   | 238 |

**GOLD BAR PROJECT**  
**S-K 1300 TECHNICAL REPORT SUMMARY**

---

|       |   |     |
|-------|---|-----|
| 19.2  | MINE PRODUCTION STATISTICS.....                           | 238 |
| 19.3  | PLANT PRODUCTION STATISTICS .....                         | 238 |
| 19.4  | CAPITAL EXPENDITURE.....                                  | 239 |
| 19.5  | REVENUE.....  | 239 |
| 19.6  | OPERATING COST.....                                       | 239 |
| 19.7  | TAXATION.....   | 240 |
| 19.8  | PROJECT FINANCING.....                                    | 240 |
| 19.9  | NET INCOME AFTER TAX.....                                 | 240 |
| 19.10 | NET PRESENT VALUE .....                                   | 240 |
| 19.11 | SENSITIVITIES.....  | 241 |
| 20    | ADJACENT PROPERTIES.....                                  | 242 |
| 21    | OTHER RELEVANT DATA AND INFORMATION .....                 | 243 |
| 22    | INTERPRETATION AND CONCLUSIONS .....                      | 244 |
| 22.1  | EXPLORATION.....  | 244 |
| 22.2  | METALLURGY AND RECOVERY .....                             | 244 |
| 22.3  | MINERAL RESOURCE ESTIMATE.....                            | 244 |
| 22.4  | MINERAL RESERVE ESTIMATE.....                             | 244 |
| 22.5  | MINING .....  | 245 |
| 22.6  | PROJECTED ECONOMIC OUTCOMES.....                          | 245 |
| 22.7  | RISKS.....  | 245 |
| 22.8  | OPPORTUNITIES.....  | 245 |
| 23    | RECOMMENDATIONS .....                                     | 247 |
| 23.1  | RECOMMENDED WORK PROGRAMS AND COSTS .....                 | 247 |
| 24    | REFERENCES .....  | 248 |
| 25    | RELIANCE ON INFORMATION SUPPLIED BY REGISTRANT .....      | 252 |
|       | APPENDIX A: CLAIMS LIST FOR GOLD BAR NORTH AND SOUTH..... | 253 |

**LIST OF FIGURES AND ILLUSTRATIONS**

| <b>FIGURE</b> | <b>DESCRIPTION</b>   | <b>PAGE</b> |
|---------------|--|-------------|
| Figure 1-1:   | Relative Position of Gold Bar Mining Areas (IMC, 2020)   | 9           |
| Figure 3-1:   | Location Map   | 20          |
| Figure 3-2:   | Gold Bar Property Map  | 23          |
| Figure 3-3:   | Gold Bar North Project Area Claims Map   | 24          |
| Figure 3-4:   | Gold Bar South Project Area Claims Map   | 25          |
| Figure 4-1:   | Gold Bar Project Access (Primary and Secondary)  | 31          |
| Figure 5-1:   | Plan view of gold envelopes provided to Telesto and used for resource model of Gold Pick deposit (Telesto, 2010)   | 44          |
| Figure 5-2:   | Gold Pick Mineralization Shell (0.006 oz/t Au) and Interpolation Domains   | 48          |
| Figure 5-3:   | Gold Pick Grade Estimation Search Ellipses and Interpolation Domains   | 48          |
| Figure 5-4:   | Gold Pick Low Recovery Zones (carbonaceous = yellow)   | 51          |
| Figure 5-5:   | GBS Grade Estimation Search Ellipses   | 54          |
| Figure 5-6:   | GBS Oblique View of Estimated Blocks Colored by Classification Code (Green=Indicated, Blue = Inferred) Source SRK 2018   | 55          |
| Figure 6-1:   | Gold Bar Property-Wide Geologic Map. Original Gold Bar Mine (OGB); Gold Canyon (GC); Gold Pick (GP); Goldstone (GS); Cabin Creek (CC);   | 61          |
| Figure 6-2:   | Gold Bar Property Stratigraphic Column (Kastelic et al., 2020)   | 62          |
| Figure 6-3:   | Gold Bar District Geologic Map with Form Lines. Original Gold Bar Mine (OGB); Gold Canyon (GC); Gold Pick (GP); Goldstone (GS); Cabin Creek (CC); Gold Bar South (GBS)                   | 63          |
| Figure 6-4:   | Gold Bar South Geologic Map  | 64          |
| Figure 6-5:   | Gold Bar South Deposit Geologic Map, Perimeter of Planned \$1,725/oz LG Mineral Resource Pit Shown in Red  | 65          |
| Figure 6-6:   | Location of Gold Bar on the Battle Mt-Eureka Trend which includes the Cortez gold deposits. Gold deposit footprints in black; McEwen properties in blue outline (Kastelic et al., 2020). | 70          |
| Figure 7-1:   | Gold in Rock Samples   | 78          |
| Figure 7-2:   | Gold in Soil Samples   | 79          |
| Figure 7-3:   | CSAMT Inverted Sections Rotated to Plan (Kastelic et al., 2020)  | 80          |
| Figure 7-4:   | Gravity Stations in Red and Black  | 81          |
| Figure 7-5:   | Horizontal Gradient Gravity Showing Major Structural Trends in the Gold Bar District (Kastelic et al., 2020).  | 82          |
| Figure 7-6:   | Residual Gravity Map of the Gold Bar Property. (Kastelic et al. (2020))  | 83          |
| Figure 7-7:   | Reduced to Pole Magnetics Map of the Gold Bar District. (Kastelic et al. (2020))   | 84          |
| Figure 7-8:   | Spectral Mineral Map of Gold Bar Property.   | 85          |



**GOLD BAR PROJECT**  
**S-K 1300 TECHNICAL REPORT SUMMARY**

---

Figure 7-9: Interpretative Spectral Cross Section through the Gold Bar District, looking NNE (Geospectral Solutions, 2020) ..... 87

Figure 7-10: Gold Bar Property Drill Hole Map..... 91

Figure 7-11: GBN Drill hole Location Map (Coordinates are UTM NAD 83 meters) ..... 92

Figure 7-12: Gold Pick Drill hole Location Map (Coordinates are UTM NAD 83 meters) ..... 93

Figure 7-13: GBS Drill hole Location Map (Coordinates are UTM NAD 83 meters)..... 96

Figure 8-1: Results of Coarse Blank and Pulp Blank Samples at GBN (McEwen, 2020) ..... 103

Figure 8-2: Graphical Representation of CRM Results in Chronological Order Mean Au Value is Represented by the Orange Line with 1, 2, and 3 Standard Deviation Lines Presented in Blue (McEwen, 2020) ..... 104

Figure 8-3: Graphical Representation of CRM Results in Chronological Order. Mean Au Value is Represented by the Orange Line with 1, 2, and 3 Standard Deviation Lines Presented in Blue (McEwen, 2020). ..... 105

Figure 8-4: Coarse Reject Duplicate Sample Pairs Relative Percent Difference vs. Average (McEwen, 2020) ..... 107

Figure 8-5: Scatter Plot of RC Rig Primary vs. Duplicate Sample Gold Assay Pairs (McEwen, 2020) ..... 107

Figure 8-6: Results of Coarse Blank and Pulp Blank Samples at GBS (McEwen, 2020)..... 110

Figure 8-7: Graphical Representation of CRM Results in Chronological Order. Mean Au Value is Represented by the Orange Line with 1, 2, and 3 Sigma Lines Presented in Blue (McEwen, 2020) ..... 112

Figure 8-8: Graphical Representation of CRM Results in Chronological Order. Mean Au Value is Represented by the Orange Line with 1, 2, and 3 Sigma Lines Presented in Blue (McEwen, 2020). ..... 113

Figure 8-9: 2011 Coarse Reject Duplicate Sample Pairs Relative Percent Difference vs. Average (McEwen, 2020) 114

Figure 8-10: Scatter Plot of RC Rig Primary vs. Duplicate Sample Gold Assay Pairs (McEwen, 2020) ..... 114

Figure 10-1: Heap Leach Pad and Discretization..... 120

Figure 10-2: Model Information and Process Flow Diagram (Forte, 2020) ..... 121

Figure 10-3: Daily Drainage Flow Rate Comparison (Forte, 2020) ..... 122

Figure 10-4: Cumulative Drainage Flow Rate Comparison (Forte, 2020) ..... 122

Figure 10-5: Monthly Gold Production Comparison (Forte, 2020) ..... 123

Figure 10-6: Cumulative Gold Production Comparison (Forte, 2020) ..... 124

Figure 10-7: Gold Bar North Extraction Rate Comparison (Forte, 2020) ..... 125

Figure 11-1: Oblique view, Gold Pick carbonaceous areas intensity >2 (McEwen, 2020) ..... 132

Figure 11-2: Oblique view, Gold Pick sulfide pods (McEwen, 2020)..... 133

Figure 11-3: Gold Pick Structural domains (McEwen, 2020) ..... 135

Figure 11-4: Example of mineralized trends within Gold Pick Domain 492 (McEwen, 2020)..... 136

Figure 11-5: Gold Pick Estimated Blocks Colored by Classification Code (Green = Indicated, Blue = Inferred) (McEwen, 2020) ..... 139

Figure 11-6: Plan View of Visual Validation Cross Section Locations for Estimated Grades, Gold Pick (McEwen, 2020) ..... 140

Figure 11-7: Section A-A' - Visual Validation of Estimated Gold Grades, Gold Pick (McEwen, 2020)..... 140

**GOLD BAR PROJECT**  
**S-K 1300 TECHNICAL REPORT SUMMARY**

|   |     |
|---|-----|
| Figure 11-8: Section B-B' - Visual Validation of Estimated Gold Grades, Gold Pick (McEwen, 2020).....                         | 141 |
| Figure 11-9: Section C-C' - Visual Validation of Estimated Gold Grades, Gold Pick (McEwen, 2020) .....                        | 141 |
| Figure 11-10: Histogram of Estimated vs. Composite Au Grades by Domain (McEwen, 2020) .....                                   | 142 |
| Figure 11-11: North-South Au Swath Plot - 120 ft Eastings (McEwen, 2020).....   | 143 |
| Figure 11-12: East-West Au Swath Plot - 120 ft Northings (McEwen, 2020) .....   | 143 |
| Figure 11-13: Elevation Au Swath Plot - 80 ft Elevations (McEwen, 2020).....  | 144 |
| Figure 11-14: East-West Reconciliation Au Swath Plot (McEwen, 2020) .....   | 145 |
| Figure 11-15: North -South Reconciliation Au Swath Plot (McEwen, 2020).....   | 145 |
| Figure 11-16: Bench Reconciliation Au Swath Plot (McEwen, 2020).....  | 146 |
| Figure 11-17: Gold Pick Sensitivity within the Gold Pick 2020 Resource Pit .....  | 147 |
| Figure 11-18: Structural Model for Gold Ridge Deposit (McEwen, 2020) .....  | 151 |
| Figure 11-19: Domains and Codes for the Gold Ridge Deposit (McEwen, 2020).....  | 152 |
| Figure 11-20: Gold Ridge Grade Estimation Search Ellipsoids and Structural Mapping, Gold Ridge (McEwen, 2020)<br>.....        | 153 |
| Figure 11-21: Gold Ridge Estimated Blocks Colored by Classification Code (McEwen, 2020) .....                                 | 155 |
| Figure 11-22: Plan View of Visual Validation Cross Section Locations for Estimated Grades, Gold Ridge (McEwen,<br>2020) ..... | 156 |
| Figure 11-23: Section D-D' – Visual Validation of Estimated Gold Grades, Gold Ridge (McEwen, 2020).....                       | 157 |
| Figure 11-24: Section E-E' – Visual Validation of Estimated Gold Grades, Gold Ridge (McEwen, 2020) .....                      | 157 |
| Figure 11-25: Histogram of Estimated vs. Composite Au Grades, Gold Ridge (McEwen, 2020).....                                  | 158 |
| Figure 11-26: North-South Au Swath Plot – 60 ft Eastings, Gold Ridge (McEwen, 2020) .....                                     | 159 |
| Figure 11-27: East-West Au Swath Plot 60 ft Northings, Gold Ridge (McEwen, 2020) .....  | 159 |
| Figure 11-28: Elevation Au Swath Plot – 40 ft Elevations, Gold Ridge (McEwen, 2020) .....                                     | 160 |
| Figure 11-29: Gold Ridge Sensitivity Within the Resource Pit (McEwen, 2020) .....   | 161 |
| Figure 11-30: Cabin Structural Domains and Stratigraphic Units (MTS, 2020).....   | 165 |
| Figure 11-31: Downhole Variogram for Combined 700-800 (MTS, 2020).....  | 166 |
| Figure 11-32: Variogram Model for Combined Dmb and Dmk (MTS, 2020). .....   | 166 |
| Figure 11-33: PCLAS Preliminary Classification with Indicated Polygon (Elevation 7090) (MTS, 2020) .....                      | 169 |
| Figure 11-34: Final Classification with Indicated Polygon (Elevation 7090) (MTS, 2020) .....                                  | 169 |
| Figure 11-35: Plan View of Visual Validation Cross Section Locations for Estimated Grades, Cabin (MTS, 2020)...               | 170 |
| Figure 11-36: Cabin Swath Plot for All Strat; Capped Grades; 10x10x10 Block Model; Indicated Mineral Resources<br>.....       | 171 |
| Figure 11-37: Cabin Swath Plot for Dmb (700); Capped Grades; 10x10x10 Block Model; Indicated Mineral Resource<br>.....        | 172 |

**GOLD BAR PROJECT**  
**S-K 1300 TECHNICAL REPORT SUMMARY**

---

Figure 11-38: Cabin Swath Plot for Dmk (800); Capped Grades; 10x10x10 Block Model; Indicated Mineral Resources ..... 172

Figure 11-39: Cabin HERCO Change of Support Plot for Au(ppm) for Indicated Mineral Resources Reblock 20x20 Model..... 173

Figure 11-40: Cabin Swath Plot for All Strat; Capped Grades; 20x20x20 Block Model; Indicated Mineral Resources ..... 174

Figure 11-41: Cabin Swath Plot for Dmb (700); Capped Grades; 20x20x20 Block Model; Indicated Mineral Resources ..... 175

Figure 11-42: Cabin Swath Plot for Dmk (800); Capped Grades; 20x20x20 Block Model; Indicated Mineral Resources ..... 175

Figure 11-43: Cabin Sensitivity within the Gold Pick 2020 Resource Pit ..... 176

Figure 11-44: Structural Model for Gold Bar South Deposit (McEwen, 2020)..... 180

Figure 11-45: Domains and Codes for the Webb Formation (McEwen, 2020)..... 180

Figure 11-46: Domains and Codes for the Devils Gate Formation (McEwen, 2020) ..... 181

Figure 11-47: Gold Bar South Grade Estimation Search Ellipsoids and Structural Mapping (McEwen, 2020) ..... 181

Figure 11-48: Gold Ridge Estimated Blocks Colored by Classification Code (McEwen, 2020) ..... 184

Figure 11-49: Plan View of Visual Validation Cross Section Locations for Estimated Grades (McEwen, 2020)..... 185

Figure 11-50: Section F-F' – Visual Validation of Estimated Gold Grades( McEwen, 2020)..... 186

Figure 11-51: North-South Au Swath Plot – 60 ft Eastings (McEwen, 2020) ..... 187

Figure 11-52: East-West Au Swath Plot – 60 ft Northings (McEwen, 2020) ..... 187

Figure 11-53: Elevation Au Swath Plot – 40 ft Elevations (McEwen, 2020)..... 188

Figure 11-54: Gold Bar South Sensitivity Within the Resource Pit (McEwen, 2020)..... 189

Figure 12-1: Gold Pick – LG Output (IMC, 2020)..... 195

Figure 12-2: Gold Pick – Phase Design (IMC, 2020) ..... 195

Figure 12-3: Gold Ridge – LG Output (IMC, 2020) ..... 196

Figure 12-4: Gold Ridge – Phase Design (IMC, 2020)..... 196

Figure 12-5: Gold Bar South – LG Output (IMC, 2020)..... 197

Figure 12-6: Gold Bar South – Phase Design (IMC, 2020) ..... 198

Figure 13-1: Gold Bar Relative Locations of Pit Designs (IMC, 2020) ..... 204

Figure 13-2: Mining Progression – End of Year 2027 (Final Pit), (IMC, 2022) ..... 213

Figure 14-1: Process Flow Sheet (Forte, 2020) ..... 215

Figure 15-1: Site Plan (McEwen, 2020) ..... 223

Figure 15-2: General Arrangement – Site Layout ..... 225

Figure 15-3: Process Area General Arrangement..... 226

Figure 16-1: 5 Year Gold Price Fluctuation..... 229

**LIST OF TABLES**

| <b>TABLE</b> | <b>DESCRIPTION</b>   | <b>PAGE</b> |
|--------------|--|-------------|
| Table 1-1:   | Sensitivity Analysis after Taxes .....   | 1           |
| Table 1-2:   | Drilling History at the Gold Bar North .....   | 3           |
| Table 1-3:   | Drilling History at the Gold Bar South Project .....   | 4           |
| Table 1-4:   | Summary of the Datasets Used for Resource Estimation .....   | 5           |
| Table 1-5:   | General Block Model Parameter Summary.....   | 5           |
| Table 1-6:   | Mineral Resource Statement (exclusive of Mineral Reserves) for the Gold Bar Gold Deposit, Eureka County, Nevada, USA, .....          | 6           |
| Table 1-7:   | Gold Bar Deposit Mineral Reserve Statement, Independent Mining Consultants, Inc. ....  | 7           |
| Table 1-8:   | Internal Cut-off Grade Applied to Reserve by Area and Process Type.....  | 11          |
| Table 1-9:   | LOM Site Operating Cost Summary.....   | 13          |
| Table 2-1:   | Identification of the Issuer .....   | 14          |
| Table 2-2:   | Abbreviations and Terms of Reference.....  | 14          |
| Table 2-3:   | Responsibilities and Sources of Information .....  | 17          |
| Table 3-1:   | Gold Bar Claims Summary .....  | 21          |
| Table 3-2:   | Corporate Structure .....  | 26          |
| Table 5-1:   | Gold Pick Indicated Mineral Resources (after Tschabrun, 1994).....   | 39          |
| Table 5-2:   | Results of Telesto's November 2008 Estimate of Gold Pick and Gold Ridge .....  | 40          |
| Table 5-3:   | Results of Telesto's May 2009 Estimate of Gold Pick and Gold Ridge.....  | 41          |
| Table 5-4:   | Results of Telesto's May 2009 Estimate of Cabin Creek .....  | 42          |
| Table 5-5:   | Results of Telesto's 2010 Estimate of Gold Pick plus Gold Ridge Resources.....   | 43          |
| Table 5-6:   | Mineral Resource Statement Gold Bar Deposit, Eureka County Nevada, SRK Consulting (U.S.) Inc., Effective November 28, 2011 .....     | 45          |
| Table 5-7:   | Density calculated at 2.5 g/cc from 95 surface samples, 74 core samples.....   | 46          |
| Table 5-8:   | Mineral Resource Statement for the Gold Bar Gold Deposit, Eureka County, Nevada, USA, SRK Consulting, Effective July 9th, 2015 ..... | 47          |
| Table 5-9:   | Mineral Resource Estimate for Gold Pick, Cabin Creek and Gold Ridge at 0.008 opt cut-off.....  | 49          |
| Table 5-10:  | Historic Non-43-101 Mineral Resource Estimates for GBS.....  | 51          |
| Table 5-11:  | Gold Bar South 2011 Mineral Resource Estimate .....  | 52          |
| Table 5-12:  | Tonnage factors supporting the 2018 SRK Resource.....  | 54          |
| Table 5-13:  | Mineral Resource Statement for Gold Bar South.....   | 55          |
| Table 5-14:  | Gold Pick/Gold Ridge Production Statistics .....   | 56          |
| Table 6-1:   | Approximate Depths and Extents of Gold Deposits in the Project Area.....   | 69          |

**GOLD BAR PROJECT**  
**S-K 1300 TECHNICAL REPORT SUMMARY**

---

|   |     |
|---|-----|
| Table 7-1: Drilling History at Gold Bar North .....   | 88  |
| Table 7-2: Locations of 2010-2011, 2018 McEwen GBN Metallurgical and Geotechnical Drill Holes ..... | 89  |
| Table 7-3: Drilling History at Gold Bar South .....   | 94  |
| Table 7-4: Locations of 2019-2020 GBS McEwen Metallurgical and Geotechnical Drill Holes .....       | 95  |
| Table 8-1: Sample Preparation Procedure.....  | 100 |
| Table 8-2: Analytical Methods for Gold .....  | 100 |
| Table 8-3: Gold Bar North Certified Reference Material Samples .....                                | 102 |
| Table 8-4: Gold Bar South Certified Reference Material Samples .....                                | 109 |
| Table 10-1: Summary of Expected Recovery for Gold Bar North Ore Types.....                          | 124 |
| Table 10-2: Summary of 2019 KCA Bottle Roll Leach Tests .....                                       | 126 |
| Table 10-3: Summary of 2019 KCA Column Leach Tests .....  | 127 |
| Table 11-1: Gold Pick and Gold Ridge 2020 Resource Model Extents.....                               | 129 |
| Table 11-2: Gold Pick Assay Capping Statistics by Interpolation Domain .....                        | 129 |
| Table 11-3: Gold Pick Composite Statistics .....  | 130 |
| Table 11-4: Gold Pick Recovery Model Risk Categorization.....                                       | 131 |
| Table 11-5: Gold Pick Tonnage Factors by Rock Type.....   | 134 |
| Table 11-6: Au Estimation Search Distances by Interpolation Domain for Gold Pick Estimation.....    | 137 |
| Table 11-7: Gold Pick Classification Parameters.....  | 138 |
| Table 11-8: Gold Ridge Assay Capping Statistics by Interpolation Domain (McEwen, 2020),.....        | 148 |
| Table 11-9: Composite Statistics, Gold Ridge (McEwen, 2020) .....                                   | 149 |
| Table 11-10: Gold Ridge Model Search Parameters, Gold Ridge (McEwen, 2020) .....                    | 153 |
| Table 11-11: Gold Ridge Classification Parameters (McEwen, 2020) .....                              | 155 |
| Table 11-12: Cabin Assay Capping Statistics by Interpolation Domain (MTS, 2020) .....               | 162 |
| Table 11-13: Cabin Composite Statistics (MTS, 2020) .....   | 163 |
| Table 11-14: Model Extents for 10x10 Block Model (MTS, 2020).....                                   | 167 |
| Table 11-15: Cabin Grade Estimation Plan (MTS, 2020).....   | 167 |
| Table 11-16: Cabin Classification Parameters.....   | 168 |
| Table 11-17: Global Bias Check by Stratigraphic Unit (MTS, 2020) .....                              | 171 |
| Table 11-18: Global Bias Check by Stratigraphic Unit for 20x20 Block Model (MTS, 2020).....         | 174 |
| Table 11-19: Assay Capping Statistics by Interpolation Domain (McEwen, 2020).....                   | 177 |
| Table 11-20: Composite Statistics (McEwen, 2020) .....  | 178 |
| Table 11-21: Gold Bar South Tonnage Factors by Rock Type (McEwen, 2020) .....                       | 179 |
| Table 11-22: Gold Bar South Model Search Parameters (McEwen, 2020).....                             | 182 |
| Table 11-23: Gold Bar South Classification Parameters (McEwen, 2020).....                           | 183 |

**GOLD BAR PROJECT**  
**S-K 1300 TECHNICAL REPORT SUMMARY**

---

|  |     |
|--|-----|
| Table 11-24: Mineral Resource Statement (exclusive of Mineral Reserves) for the combined Gold Bar Gold Deposit, Eureka County, Nevada, USA, Effective 1 January, 2022..... | 190 |
| Table 11-25: Risks by Category.....  | 191 |
| Table 12-1: Economic Input Parameters (IMC, 2022).....   | 193 |
| Table 12-2: Economic Input Parameters (IMC, 2021).....   | 194 |
| Table 12-3: McEwen Mining Inc. – Gold Bar Deposit Mineral Reserve Statement (Imperial Units); .....  | 200 |
| Table 12-4: Internal Cut-off Grades (IMC, 2022).....   | 201 |
| Table 12-5: Risks by Category.....   | 202 |
| Table 13-1: Overall Pit Slopes .....   | 205 |
| Table 13-2: Road Design Parameters.....  | 206 |
| Table 13-3: Fleet Requirements (IMC, 2020).....  | 210 |
| Table 13-4: Material Characteristics (IMC, 2020).....  | 210 |
| Table 13-5: Utilization and Availability of Mining Equipment (IMC, 2020).....  | 210 |
| Table 13-6: Fleet Requirements (IMC, 2022).....  | 211 |
| Table 13-7: Operating Time Per Shift (IMC, 2022).....  | 212 |
| Table 14-1: Key Crushing, Agglomeration and Stacking Process Design Parameters (Forte, 2020) .....   | 216 |
| Table 14-2: Key Heap Leach Process Design Parameters.....  | 217 |
| Table 14-3: Key ADR Process Design Parameters (Forte, 2020).....   | 219 |
| Table 14-4: Major Reagent Consumption (Forte, 2020).....   | 221 |
| Table 16-1: Gold Price Estimates US\$/troy ounce (Bloomberg, December 2021).....   | 229 |
| Table 17-1: Potential Permits Required for the Gold Bar Mine .....   | 230 |
| Table 18-1: LOM Cost Summary .....   | 236 |
| Table 18-2: Operating Costs for Mining Area.....   | 237 |
| Table 19-1: Life of Mine Ore, Waste and Metal Grades.....  | 238 |
| Table 19-2: Average Metal Recovery Factors.....  | 238 |
| Table 19-3: Life of Mine Production Summary .....  | 238 |
| Table 19-4: Refining Terms.....  | 239 |
| Table 19-5: LOM Site Average Operating Cost Summary .....  | 239 |
| Table 19-6: Sensitivity Analysis after Taxes .....   | 241 |
| Table 19-7: Sensitivity Analysis after Taxes to Various Factors .....  | 241 |

**LIST OF APPENDICES**

| <b>APPENDIX</b> | <b>DESCRIPTION</b>                       |
|-----------------|--|
| A               | Claims List for Gold Bar North and South |

## 1 EXECUTIVE SUMMARY

M3 Engineering & Technology Corporation (M3) was commissioned by McEwen Mining Inc. (McEwen) to prepare a Technical Report Summary (TRS) in compliance with the United States Securities and Exchange Commission (SEC) regulation S-K subpart 1300 (S-K 1300) of the Gold Bar Mine (Gold Bar or the Project), an open pit gold heap leach operation located in Eureka County, Nevada.

The purpose of this TRS is to disclose at a Feasibility Study (FS) level the technical and economic analysis of the current operations for the Project including detailed assessments of resources and reserves, metallurgy, mining, processing, environmental, social, legal, and other relevant considerations that have successfully demonstrated the economic viability of the Project. This section briefly summarizes the findings of the FS.

McEwen began construction on Gold Bar in November 2017 and plant commissioning was completed in Q1 2019. Gold Bar is currently in operation and is expected to continue for several years.

### II KEY RESULTS

The key results of this Technical Report were as follows:

- Average annual gold production is anticipated to be 44,150 oz at a cash operating cost of \$1,197/oz.
- Updated Proven and Probable Reserves are calculated at 15.5 million tons at a gold grade of 0.024 oz/t (0.82 g/t) resulting in 260,200 oz of gold produced over 7 years.
- Updated Mineral Resource Estimate includes 82,400 contained oz of Measured & Indicated Mineral Resources and 44,400 contained oz of Inferred Mineral Resources.
- A geometallurgical model was created to incorporate silicification, clay and refractory aspects of each deposit, allowing for better recovery estimates.
- Updated metallurgical studies confirm an overall average Life-of-Mine recovery of gold of 72%.
- Net Income after Tax is approximately \$72.2 million for the life of the mine.

### 1.2 ECONOMIC ANALYSIS

The base case economic analysis indicates that the project has an NPV at 8% discount rate of \$57.2 million. The payback period and IRR were not calculated as this is an ongoing operation. An upside case is presented in Table 1-1 where the gold price is increased to \$1,800 per ounce.

**Table 1-1: Sensitivity Analysis after Taxes**

|   | <b>Base Case<br/>\$1,650/oz gold</b> | <b>Upside Case<br/>\$1,800/oz gold</b> |
|---|--------------------------------------|--|
| NPV (5% Discount Rate) <sup>(2)</sup>   | \$62.2 million                       | \$95.1 million                         |
| NPV (8% Discount Rate) <sup>(2)</sup>   | \$57.2 million                       | \$87.7 million                         |
| Average Annual Cash Flow <sup>(3)</sup> | \$12.0 million                       | \$18.3 million                         |
| Average Margin to Cash Costs            | \$453/oz                             | \$603/oz                               |
| Average Margin to AISC                  | \$290/oz                             | \$434/oz                               |

Notes:

1. "oz" means Troy ounce(s).
2. NPV is discounted to January 1, 2022.
3. Average Annual Cash Flow during production years.
4. Upside Case may not capture impact from taxes after the loss carryforward is consumed



### **1.3 PROPERTY DESCRIPTION AND OWNERSHIP**

The Gold Bar Project is located in the southern Roberts Mountains, approximately 30 miles northwest of the town of Eureka in Eureka County, Nevada. The approximate centroid of the north deposit areas in the current mine plan is N39.80°, W116.34°. The Project has good connections to the infrastructure of northern Nevada, with public roads linking to a haul road that connects the historical Gold Bar plant to the Project site. The area is characterized as high mountain desert with cold winters and warm summers. Project elevations range from 6,500 ft to 9,063 ft. Weather-related impact to previous mining at Gold Bar was minimal.

The Project area covers approximately 56,800 acres. This area consists of patented and unpatented mining claims. McEwen, through its wholly owned subsidiaries McEwen Mining Nevada Inc., WKGUS LLC, and Golden Pick LLC, controls 2,808 unpatented lode mining claims and one parcel of privately owned land in the Project area. The parcel consists of 10 patented lode claims, which cover most of the Gold Pick (Pick) and Gold Ridge (Ridge) resource areas. The Gold Bar South (GBS) claim block has 188 unpatented and 22 patented mining claims (comprised of Afgan, Nickel, Kobeh, Predator, and AG) on approximately 5,264 acres. All unpatented mining claims are held by McEwen Mining Nevada, Inc. and are subject to a 1% NSR royalty.

The CC and SW claims held by McEwen Mining Nevada Inc. are subject to a 1% Net Smelter Returns (NSR) royalty. The CC claims cover the bulk of the Cabin Creek mineral resource.

The CC claims are also subject to a 10% Net Profits Interest (NPI) royalty.

### **1.4 GEOLOGY AND MINERALIZATION**

Within the GBN area, three gold deposits have been defined: Gold Pick, Gold Ridge and Cabin Creek. Mineralization in Pick has a strike length of over 4,000 ft with a width of 1,600 ft and thickness of 100 – 150 ft. Gold Ridge and Cabin Creek are ancillary deposits comprising together approximately 22% of the mineral resource. All defined mineralization lies within 500 ft of surface in oxidized carbonate host rocks.

Lower plate Paleozoic-aged carbonates comprise approximately 30% of the surface exposures and host all of the known deposits in the GBN area (Atlas, 1996). The main stratigraphic unit containing the vast majority of the significant mineralization in the immediate vicinity of McEwen's claims. This is the Bartine Member of the McColley Canyon Formation. It is a well-bedded limestone that has good primary porosity and lateral permeability that allowed movement of hydrothermal fluids. The Pick, Gold Ridge and Cabin Creek deposits are found in the McColley Canyon Formation.

While high-angle structures were an important influence for localizing gold deposition, the debris flows in the Bartine allowed lateral movement of the mineralizing fluids and resulted in bedding-parallel mineral continuity. The intersection of the high-angle fractures and faults with the receptive debris flows of the Bartine Member resulted in the formation of the gold deposits in the Project area. Significant mineralization followed the trend of the debris flows, especially where they filled the topographic lows on the surface of the Lone Mountain dolomite. The inherent irregular nature of the debris flows and intersecting structures resulted in the development of many pods and shoots of mineralization. Thicker and more continuous pods developed at the intersections of high-angle fractures with the Bartine debris flows (Kastelic, 2010, pers. comm.).

Mineralization in the GBN deposits is closely related to decalcification and to a lesser extent with silicification along high angle structures. Carbon and calcite have commonly been remobilized. Calcite veins are typically found in the vicinity of mineralization. Decalcification is the result of progressive dissolution of the limestone host rock. Decalcified limestones generally become soft and porous and do not crop out, often occurring under thick soil cover. The decalcified rock can be either unoxidized (carbonaceous) or oxidized. The more intensely decalcified zones in the mineralized areas correlate well with higher grades. Primary pyrite/marcasite and arsenopyrite generally replace iron-bearing minerals and form disseminations in unoxidized host rocks. They are generally fine grained and 1 mm to 1

micron in size. Late botryoidal pyrite/marcasite is present in some deposits. Most orpiment, realgar, stibnite, cinnabar, and barite are found in open space along fractures and in breccias in unoxidized host rocks.

Gold mineralization at GBS was deposited in brecciated siltstones of the Webb Formation, at and immediately above its underlying contact with the Devils Gate Limestone. Lesser but important amounts of mineralization occur in the adjacent Devils Gate Limestone as well. Mineralization in GBS consists of epithermal, disseminated, sediment-hosted gold, in zones related to hydrothermal dissolution in limestone and the resulting collapse breccia in the overlying siliciclastic unit. Gold is associated with brecciated, oxidized, silicified, and argillized mudstones, siltstones, and sandstones of the Webb Formation and is usually accompanied by silicification and strong barite veining. Jasperoid along the trace of the fault is brecciated and contains veins of barite and scattered gold mineralization. In contrast to the sediment-hosted GBN deposits, GBS gold mineralization is associated with brecciation. All known mineralization at GBS is oxidized and amenable to heap leach extraction.

## 1.5 EXPLORATION

The majority of exploration drilling at GBN was completed by Atlas in the early 1990's and more recently by McEwen (then US Gold) from 2008 to 2020. The drilling history for GBN is summarized in Table 1-2. More than 95% of the drill holes supporting GBN are reverse circulation (RC). The rest are HQ and PQ-diameter core drilled primarily for geotechnical or metallurgical studies.

**Table 1-2: Drilling History at the Gold Bar North**

| Project Phase                          | Number of Holes | Total Feet Drilled |
|--|-----------------|--------------------|
| Pre-2007                               | 2,403           | 994,292            |
| McEwen* 2007-2010                      | 160             | 112,108            |
| McEwen* 2010-11 Met/Geotech            | 17              | 7,551              |
| McEwen 2015 Infill/Upgrade             | 38              | 13,365             |
| McEwen 2017 Infill/Upgrade             | 16              | 9,980              |
| McEwen 2018 Infill/Upgrade/Met         | 63              | 42,675             |
| McEwen 2019 Infill/Upgrade             | 75              | 36,070             |
| McEwen 2020 Infill/Upgrade             | 179             | 67,725             |
| McEwen 2021 Infill/Upgrade/Geotech/Met | 53              | 13,767             |
|  | <b>3,004</b>    | <b>1,297,533</b>   |

Source McEwen, 2020

Notes:

\* McEwen was incorporated as US Gold at this time

Since the last Technical Report updating resources in 2020 the drilling program focused on West Pick. It was designed to meet several objectives using a mix of oriented core and RC holes to complement recent highwall mapping and provide the foundation for a robust 3D geologic model, which in turn would support the resource model.

Drilling in 2021 dominantly focused on Gold Ridge and Cabin North. At Gold Ridge, drilling was designed to better define and extend mineralization in the northern portion of the deposit, provide samples for metallurgical test work, and provide geotechnical information for highwall stability. A total of 36 drill holes were completed at Gold Ridge for an aggregate of 13,750 feet consisting of 17 reverse circulation drill holes (7,880 feet) and 17 HQ/PQ core holes (5,870 feet).

Drilling at the Cabin North deposit was designed to refine controls to mineralization and expand mineralization at depth and to the north of the deposit. A total of 16 HQ core holes were completed for a cumulative 3,435 feet.

**GOLD BAR PROJECT**  
**S-K 1300 TECHNICAL REPORT SUMMARY**

Reverse circulation (RC) drill holes comprise 87% of the total holes and 86% of the total footage drilled to date at Gold Bar South (GBS). Approximately 5% of the total holes were completed with a rotary or air track drill rig early in the project's history with many of these holes located outside the resource area. Core holes were drilled in 1993, 2019 and 2020 for metallurgical, geotechnical, and geologic data and account for 7% of the holes drilled at GBS and 9% of the total footage. A summary of the GBS drilling history is presented in Table 1-3. Since 2015, 303 RC holes and 30 core holes totaling 87,305 feet were drilled. Most of the recent drill holes are in the Resource area, while others were designed to test step out targets adjacent to the modeled area.

**Table 1-3: Drilling History at the Gold Bar South Project**

| Company                                 | Year                 | Rotary           |              | RC                 |                | Air-track |            | Core      |               | Total Drill Holes | Total Footage  |
|---|----------------------|------------------|--------------|--------------------|----------------|-----------|------------|-----------|---------------|-------------------|----------------|
|   |                      | No.              | Feet         | No.                | Feet           | No.       | Feet       | No.       | Feet          |                   |                |
| Amselco                                 | 1981                 | 24               | 6,860        |                    |                |           |            |           |               | 24                | 6,860          |
| Hecla                                   | 1986                 |                  |              | 8                  | 2,850          |           |            |           |               | 8                 | 2,850          |
| LFC Trust                               | 1989-90 <sup>1</sup> |                  |              |                    |                | 9         | 994        |           |               | 9                 | 994            |
| Santa Fe                                | 1988-89              |                  |              | 13                 | 5,130          |           |            |           |               | 13                | 5,130          |
| Phelps Dodge                            | 1990-91              |                  |              | 63                 | 15,640         |           |            |           |               | 63                | 15,640         |
| Great Basin                             | 1993                 | [2] <sup>2</sup> | 604          | 6+[1] <sup>2</sup> | 4,107          |           |            | 9         | 4,370         | 15                | 9,081          |
| Cominco                                 | 1996                 |                  |              | 16                 | 11,695         |           |            |           |               | 16                | 11,695         |
| Midway                                  | 2007                 |                  |              | 8                  | 3,250          |           |            |           |               | 8                 | 3,250          |
| NV Gold                                 | 2010                 |                  |              | 25                 | 7,803          |           |            |           |               | 25                | 7,803          |
| NV Gold                                 | 2011                 |                  |              | 23                 | 8,440          |           |            |           |               | 23                | 8,440          |
| McEwen, Step out                        | 2016                 |                  |              | 12                 | 6,565          |           |            |           |               | 12                | 6,565          |
| McEwen, Infill/ Upgrade / Met / Geotech | 2019                 |                  |              | 209                | 47,765         |           |            | 10        | 2,240         | 219               | 50,005         |
| McEwen, Infill / Step out / Met         | 2020                 |                  |              | 82                 | 22,850         |           |            | 20        | 7,885         | 102               | 30,735         |
| <b>TOTAL</b>                            |                      | <b>24</b>        | <b>7,464</b> | <b>465</b>         | <b>136,095</b> | <b>9</b>  | <b>994</b> | <b>39</b> | <b>14,495</b> | <b>537</b>        | <b>159,048</b> |

Source: MDA, 2011, SRK, 2018, and McEwen, 2020.

Notes:

<sup>1</sup> 15 air-track holes drilled in 1988 not included in database or Table 1-3.

<sup>2</sup> Holes in [brackets] drilled as pre-collars to core holes.

<sup>3</sup> Holes drilled in 2019 and 2020 have not been previously reported in an NI 43-101 Mineral Resource Estimation.

Recent results support resource model estimations and confirm existing data from respective nearby drill holes. Primary assay results indicate that preparation and analytical procedures are defensible, and results are suitable for inclusion in resource and reserve models.

**1.6 METALLURGICAL TESTING AND PROCESS DESIGN CRITERIA**

The Gold Bar North deposit has been subject to extensive metallurgical testing starting in 1988 until early 2017. Samples have been tested at bottle roll and column leaching scale, and under varying processing conditions including crush size, agglomeration/no agglomeration, cyanidation rate, permeability, and others. In addition, this work was supplemented by actual heap leach pad performance of material from GBN.

The ore mineralogy of the Gold Bar North deposits consists of an intermixing of oxidized and un-oxidized refractory ores with variable leach recovery. Gold Bar North contains both oxide and un-oxidized refractory gold bearing material. The refractory material is not disseminated throughout the deposit, but rather exists as distinguishable areas. This refractory ore can be identified during grade control using both visual and analytical methods, including cyanide soluble, organic carbon, and total sulfur assays. The un-oxidized high-grade refractory material, which is poorly amenable to

**GOLD BAR PROJECT**  
**S-K 1300 TECHNICAL REPORT SUMMARY**

cyanidation and pre-robbing in nature, should not be placed on the heap with the oxide ore and instead will be treated as designated waste.

The metallurgical development of Gold Bar North selected a processing circuit that included primary crushing to 100% -6" followed by screening and agglomeration of the -3" fraction with a recovery projection of 82%. Initiation of mining activities in Gold Bar North began December 5, 2018 with the first loading of ore onto the heap leach pad. Since then, approximately 6.494 Mtons of ore have been placed with approximately 38% placed as ROM. Updated recovery estimates have been generated to account for the amended processing and placement strategy. Analysis of results from fully dynamic leaching models indicate an average of 78% recovery of crushed oxide ore and 72% recovery for ROM.

The Gold Bar South deposit has preliminary metallurgical characterization limited to bottle roll test results completed between 2008 and 2011, column testing in 2019, and cyanide digestion gold assays from several drilling programs throughout the history of the Project. Column testing completed from drill core obtained in 2019 show extractions ranging from 59% to 91%. A deposit-wide recovery estimate of 61% is suggested based on placing and leaching material as ROM.

**1.7 MINERAL RESOURCE ESTIMATE**

The Mineral Resources in this report were estimated and reported using the regulation S-K 1300 of the United States Securities and Exchange Commission ("SEC") and with the Canadian Institute of Mining, Metallurgy, and Petroleum (CIM) Definition Standards for Mineral Resources and Mineral Reserves, November 20, 2019 (CIM, 2019). Accordingly, the Mineral Resources have been classified as Measured, Indicated, or Inferred Mineral Resources. The mineral resource estimate and related geologic modeling were reviewed by and approved by Michael Baumann, C.P.G. Mr. Baumann is a Qualified Person and an employee of McEwen for purposes of this Technical Report Summary.

This Mineral Resource Estimate consists of 4 distinct areas: Gold Pick, Gold Ridge, Cabin and Gold Bar South. General data statistics for each deposit are outlined in Table 1-4. Most of the drilling supporting the resource estimate was performed using RC methods with minimal core drilling.

**Table 1-4: Summary of the Datasets Used for Resource Estimation**

| Deposit        | Number Drill holes | Assay Intervals* | % Core Drilling* | Cut-Off Date       |
|----------------|--------------------|------------------|------------------|--------------------|
| Gold Pick      | 1807               | 150,000          | 2%               | October 29, 2020   |
| Gold Ridge     | 424                | 49,000           | 2%               | October 14, 2020   |
| Cabin          | 193                | 15,400           | 5%               | September 29, 2020 |
| Gold Bar South | 504                | 27,800           | 8%               | September 3, 2020  |

\*Approximate values

However, when core drilling has been used, correlations between drill methods are adequate to good, providing sufficient confidence for application of the data in resource modeling. All drilling used in the estimates has been above the water table; therefore, there are no issues related to drilling wet RC holes in the database. The 3D geologic structural and stratigraphic modeling was updated in 2020 from field mapping and drill hole logging. Domaining for all deposits utilizes the updated 3D geologic models. Gold was estimated into block models using varying methods as outlined in Table 1-5.

**Table 1-5: General Block Model Parameter Summary**

| Deposit   | Number Domains | Composite Length | Interpolated Block Size | Modeling Method           |
|-----------|----------------|------------------|-------------------------|---------------------------|
| Gold Pick | 47             | 5 ft             | 20x20x20                | Dynamic Anisotropy and OK |

**GOLD BAR PROJECT  
S-K 1300 TECHNICAL REPORT SUMMARY**

|                |    |       |          |                            |
|----------------|----|-------|----------|----------------------------|
| Gold Ridge     | 32 | 10 ft | 20x20x20 | ID3                        |
| Cabin          | 42 | 10 ft | 10x10x10 | OK                         |
| Gold Bar South | 42 | 10 ft | 20x20x20 | Dynamic Anisotropy and ID3 |

Potentially deleterious carbon and sulfide were modeled using CN:FA ratios for gold, Total Organic Carbon, Total Sulfide and Total Sulfur Sulfide along with qualitative logging. A risk code was then assigned to blocks based on the results and recovery factors were assigned to the block models based on this assessment of risk. Silicification was also modeled for Pick, Gold Ridge, and Gold Bar South from qualitative logging. The Gold Bar South model contains sufficient amounts of silicification to warrant that the recovery is adjusted based on metallurgical tests performed on the silicified material.

Density for Gold Pick, Gold Ridge, and Cabin was derived from historic production and 2011 test work on drill core. Density was assigned based on material type. Additional testing during 2019 and 2020 was used to determine density by rock type and alteration for Gold Bar South.

The 2022 full Statement of Mineral Resources for the Project using a variable cut-off grade is 16.9 Mt at 0.027 oz/t Au of Indicated Resources resulting in 452 koz Au, and an additional 2.0 Mt at 0.023 oz/t Au of Inferred Resources resulting in 44 koz Au, with an effective date of 31 December 2021. Measured Resources were reclassified as Indicated based on on-going work to determine density values and mineralogy that could potentially affect recovery.

The resource models were constrained within a Lerchs-Grossmann (LG) pit optimization to ensure that the resource has a reasonable stripping ratio and meets the criteria of having a reasonable potential for eventual economic extraction. The mineralization within the LG pit was then tabulated using the \$1,725/oz gold price which results between 0.0066 oz/t to 0.0110 oz/t cut-off grade, depending on source, material type and process type.

It is important to recognize that these discussions of surface mining parameters are used solely to test the “reasonable prospects for eventual economic extraction,” and do not represent an attempt to estimate mineral reserves. These preliminary evaluations are used to prepare a Mineral Resource Statement and to select appropriate reporting assumptions.

**Table 1-6: Mineral Resource Statement (exclusive of Mineral Reserves) for the Gold Bar Gold Deposit, Eureka County, Nevada, USA, 1 January 2022**

| Classification | Cut-off Grade (oz/t) | Mineralized Tons (ktons) | Gold Grade                  |                             | Gold Metal                     |                                |
|----------------|----------------------|--------------------------|-----------------------------|-----------------------------|--------------------------------|--------------------------------|
|                |                      |                          | Contained Gold Grade (oz/t) | Recovered Gold Grade (oz/t) | Contained Metal (000's ounces) | Recovered Metal (000's ounces) |
| Indicated      | Variable             | 1,479                    | 0.056                       | 0.041                       | 82.4                           | 61.9                           |
| Inferred       | Variable             | 1,955                    | 0.023                       | 0.016                       | 44.4                           | 31.8                           |

Notes:

- The Mineral Resource was prepared under the direction of Michael Baumann, RM SME and C.P.G. Mr. Baumann is a Qualified Person (QP) under S-K 1300 who takes responsibility for it.
- Mineral Resources do not have demonstrated economic viability. The estimate of Mineral Resources may be materially affected by environmental, permitting, legal, title, taxation, socio-political, marketing, or other relevant issues.
- Mineral resources are based on the following economic input parameters: \$3.19/ore ton mining cost, \$1.99/waste tone mining cost, \$4.91/ore ton crushed process cost, \$3.77/ore ton ROM process cost, \$3.16/ore ton G&A cost, \$0.475/toz gold refining charge, \$1.538/toz transport & sales cost, 99.95% payable gold, 1% royalty at GBS only, 78% crushed oxide recovery at Pick & Ridge, 50% mid-carbon recovery at Pick & Ridge, 72% ROM oxide recovery at Pick & Ridge, 61% ROM oxide recovery at GBS, 0% ROM mid-carbon recovery
- The stated Resources above are based on a variable cut-off grade based on rock type, mining area, carbon content, clay content, and process response
- Resources stated in the table above are contained within a \$1,725/oz Gold sales price Lerchs-Grossmann (LG) pits.

**GOLD BAR PROJECT  
S-K 1300 TECHNICAL REPORT SUMMARY**

- ktons means 1000 short tons; Short tons = 2000 lbs.
- Gold is reported in Troy Ounces per Short Ton
- Based on end of December 2021 topography
- The Mineral Resources in this report were estimated and reported using the regulation S-K 1300 of the United States Securities and Exchange Commission ("SEC"). Mineral Resources stated in the table are exclusive of Mineral Reserves.

**1.8 MINERAL RESERVE ESTIMATE**

The mineral reserve was developed from the block model and is the total of all proven and probable category ore that is planned for processing. The mineral reserve was established by tabulating the contained tonnage of measured and indicated material (proven and probable) within the designed final pit at the planned cut-off grade.

The final pit design and the internal phase (pushback) designs were guided by the results of the Lerchs-Grossmann (LG) algorithm. The final pit design is based on pit economics between \$1,250/oz & \$1,400 LG pits. The mineralization within the final pit geometry was then tabulated using the \$1,650/oz gold price which results between 0.0300 oz/t to 0.0121 oz/t cut-off grade, depending on source, material type and process type.

The 2021 Statement of Mineral Reserves for Gold Bar is summarized in Table 1-7.

**Table 1-7: Gold Bar Deposit Mineral Reserve Statement, Independent Mining Consultants, Inc.  
McEwen Mining Inc. – Gold Bar Deposit**

Mineral Reserve Statement (Imperial Units); January 1, 2022

| Classification    | Cut-off Grade (oz/t) | Mineralized Tons (ktons) | Gold Grade                  |                             | Gold Metal                     |                                |
|-------------------|----------------------|--------------------------|-----------------------------|-----------------------------|--------------------------------|--------------------------------|
|                   |                      |                          | Contained Gold Grade (oz/t) | Recovered Gold Grade (oz/t) | Contained Metal (000's ounces) | Recovered Metal (000's ounces) |
| Probable          | Variable             | <u>15,491</u>            | <u>0.024</u>                | <u>0.017</u>                | <u>370</u>                     | <u>260</u>                     |
| Total Prov + Prob |                      | 15,491                   | 0.024                       | 0.017                       | 370                            | 260                            |

Notes:

- The Mineral Reserve was provided by Independent Mining Consultants, Inc. (IMC), an independent third-party contractor.
- Based on IMC's knowledge there are no environmental, permitting, legal, title, taxation, socio-economic political issues that would materially affect these Mineral Reserves.
- Mineral Reserves equal the total ore planned for processing as of January 1<sup>st</sup>, 2022 from the mine plan based on a \$1,650/oz gold
- Mineral reserves are based on the following economic input parameters: \$3.80/ avg. ore ton mining cost, \$2.88/ avg. waste ton mining cost, \$4.91/ore ton crushed process cost, \$3.77/ore ton ROM process cost, \$3.22/ore ton G&A cost, \$0.475/toz gold refining charge, \$1.538/toz transport & sales cost, 99.95% payable gold, 1% royalty at GBS only, 78% crushed oxide recovery at Pick & Ridge, 50% mid-carbon recovery at Pick & Ridge, 72% ROM oxide recovery at Pick & Ridge, 61% ROM oxide recovery at GBS, 0% ROM mid-carbon recovery. The stated Reserves above are based on a variable cut-off grade based on rock type, mining area, carbon content, clay content, and process response.
- Reserves stated in the table above are contained within an engineered pit design between the US\$1,250/oz, and \$1,400/oz Gold sales price Lerchs-Grossmann (LG) pits.
- The stated Mineral Reserves above are not additional to the Mineral Resource (Mineral Reserves are not included in the Mineral Resources )
- The reserve is only categorized as probable because model only tabulated to a confidence level of indicated.
- ktons means 1000 short tons; Short tons = 2000 lbs.
- Gold is reported in Troy Ounces per Short Ton
- Based on end of December 2021 topography
- The Mineral Resources in this report were estimated and reported using the regulation S-K §229.1304 of the United States Securities and Exchange Commission ("SEC").

Independent Mining Consultants, Inc. is responsible for the mineral reserve.

The mine plan assumes that the mine operator will be able to selectively mine the ore zones. The model has estimated carbonaceous, clay content, and other low recovery zones are known to impact recoveries and resulting haulage destination. Adjustments to the modeled zones of carbon, low-recovery and/or clay content could have positive or

negative impacts to the project. Multi-factored identification of material is often difficult to successfully achieve at operations. Correctly identifying and segregating the various zones during mining activity will be a key factor impacting the project economics. The multi-factored identification of various zones is a project risk and should be mitigated with a rigorous ore control program.

In accordance with regulation S-K §229.1304 of the United States Securities and Exchange Commission (“SEC”) and the CIM classification system only Measured and Indicated resource categories were converted to reserves (through inclusion within the open-pit mining limits). In this Mineral Reserve Statement, Inferred Mineral Resources are reported as waste.

## **1.9 MINING METHODS**

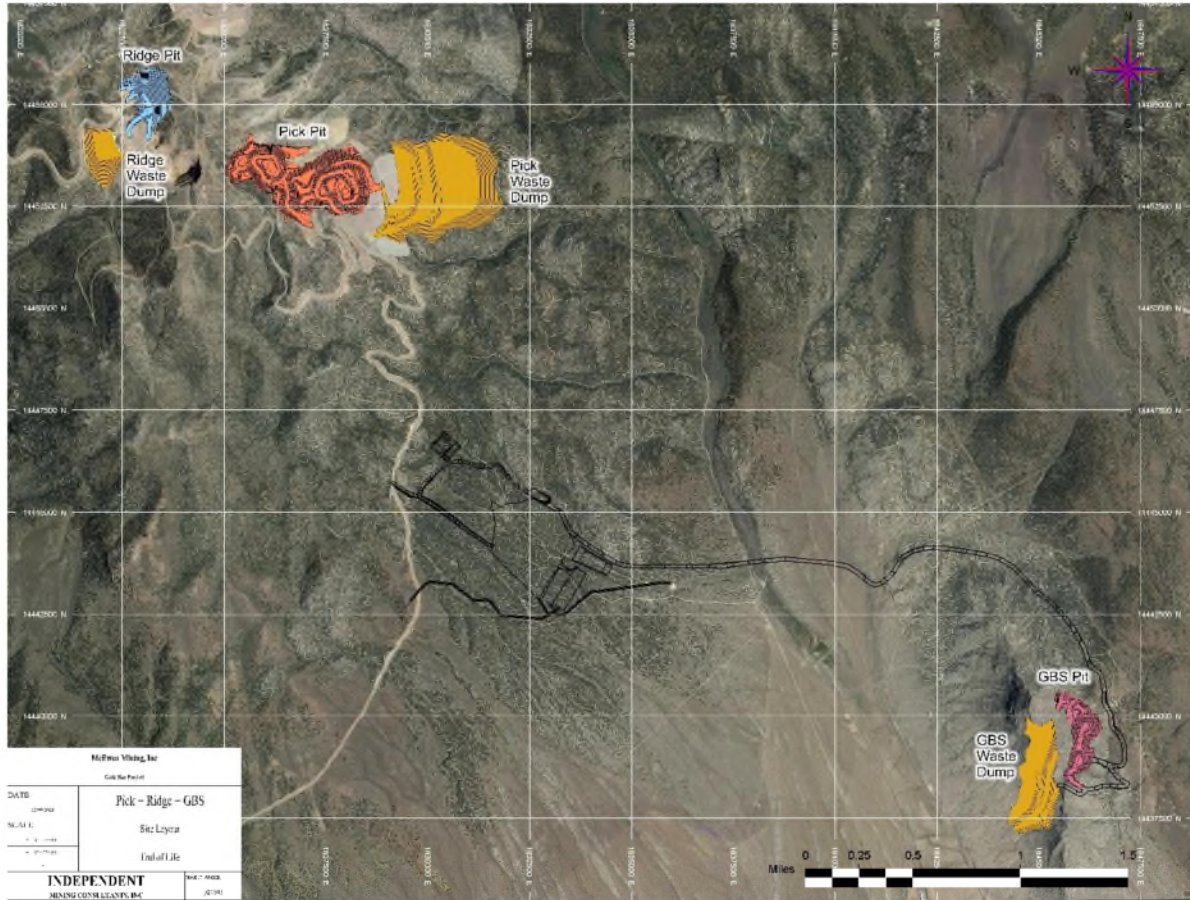
The Gold Bar project is planned for production using conventional hard rock open pit mining methods. The Gold Bar Project is currently and will continue being mined by a contractor. Contractor equipment on hand is often variable. There is flexibility in the fleet size and the actual mining fleet will likely vary depending on the contractor’s fleet on hand. The schedule and production requirements were based on 20-ft benches and the following fleet assumptions:

- Drilling will be completed with a fleet of four rotary drills with 45,000 lb pull down capacity and 6.75-inch diameter blast holes.
- The blasted rock will be loaded into 100-ton haul trucks using three 16-cu yd front end loaders.
- The auxiliary fleet will consist of two water trucks, three track dozers, one wheel dozer, one excavator, two graders, one auxiliary loader and an auxiliary truck.

The mine plan was developed with a phase approach. The phase designs, mine schedule, and mine equipment requirements are summarized in Section 13 and 18.

The mining was split between three mining areas: Pick, Gold Bar South, and Gold Ridge. Figure 1-1 illustrates the relative position of the three mining areas. The phases were tabulated from the block model and those tabulations were used as input to the development of the mine production schedule.

**GOLD BAR PROJECT  
S-K 1300 TECHNICAL REPORT SUMMARY**



**Figure 1-1: Relative Position of Gold Bar Mining Areas (IMC, 2020)**

Waste rock will be stored in several waste rock facilities designed in close proximity to each pit to reduce haulage costs. Whenever possible, pit backfilling will be utilized if doing so proves to be economic during operations. Some waste mined late in the mine life will be placed in a designated storage facility to meet closure requirements.

Gold Bar has been in operation for over two years and is currently producing metal at site. A significant amount of access road development has already been completed by the previous and current operators. Future mine development and access construction will be performed by a contractor. Access to many areas of the mine have already been established from previous mining activity. Widening and recontouring of existing and new initial roads will be required to access the future mining areas of Ridge and Gold Bar South (GBS). Planned future access roads will be constructed utilizing tracked dozers, hammer blasthole rigs, and the proposed 100 t ore mining fleet with a front-end loader.

The mineralization within the final pit was tabulated using the cut-off grades reported below in



**GOLD BAR PROJECT**  
**S-K 1300 TECHNICAL REPORT SUMMARY**

---

Table 1-8 and are based on a \$1,650/oz gold price. All areas of the mine are planned at 20 ft bench heights. The mining bench advance rate does not exceed 18 benches per year from each area.

**Table 1-8: Internal Cut-off Grade Applied to Reserve by Area and Process Type**

| Internal Cut-off Grades (oz/ton) |                   |                   |                              |                  |
|----------------------------------|-------------------|-------------------|------------------------------|------------------|
| Process:                         | ROM Only          | To Crusher        |                              |                  |
| <i>Mining Area</i>               | <i>Oxide Only</i> | <i>Oxide Only</i> | <i>Mid-Carbon / Low Rec.</i> | <i>High Clay</i> |
| Pick                             | 0.0065            | 0.0300            | 0.0107                       | 0.0069           |
| Ridge                            | 0.0075            | 0.0300            | 0.0121                       | 0.0078           |
| GBS                              | 0.0085            | N/A               | N/A                          | N/A              |

The multiple schedules were evaluated on a NPV basis at the project design prices that were used to establish the mineral reserve (Section12). The best overall production schedule on an economic and practical basis was selected.

The Gold Bar Project is planned for production using conventional hard rock open pit mining methods. Ore production to the crusher is planned at a maximum capacity of 7,500 tpd (2,750 ktons/yr). Additional run of mine (ROM) material will be placed when available. The maximum ore production to the leach pad (crushed & ROM) is planned to be 7,900 tpd (2,880 ktons/yr). The mine production schedule was developed with the goal of filling the crusher at the required ore rate and maximizing the project return on investment. The mine production schedule will not maintain full production during years 2024, resulting in 41% reduction of ore delivery during 2024.

The total material rate is tied to equipment productivity and fluctuates by period. The maximum total production is expected to reach a rate of 64,700 tons/day (23,600 ktons/yr). The mine is scheduled to operate 7 days/wk with two, 12-hour shifts/day.

The waste is defined as any material that falls below the economic cut-off grade. The non-designated waste is composed primarily of oxidized and un-oxidized carbonate (limestone and dolomite) with localized clay alteration. Designated Waste is defined as any un-oxidized material, regardless of gold grade, whose content of organic carbon and sulfides make it refractory and preg robbing in heap leach processing. The designated waste has a low potential to generate acid, but a high potential for metal/metalloid release under expected neutral pH weathering conditions. Designated waste, which is generated entirely from the Pick pit, will be stored in a repository immediately to the southeast of that pit.

Three waste storage facilities are planned at each of the remaining mining areas of Pick, Ridge and Gold Bar South. The Pick waste will expand from the historic Pick waste dump east of the planned Pick phases between Pick and Cabin (already mined) areas. The Ridge waste will expand from the historic Ridge waste dump located southwest of the Ridge pit. GBS will be placed southwest of the planned pit at GBS.

### **1.10 MINERAL PROCESSING AND RECOVERY METHODS**

The remaining gold deposit at Gold Bar will be mined as three open pits: Gold Ridge (Ridge), Pick and Gold Bar South (GBS). Precious metal recovery from the mine in this updated Feasibility Study is through conventional heap leaching and adsorption, desorption, and regeneration (ADR) technology for metal extraction from crushed ore. The ore agglomeration has been reduced to the high-clay ores processed, or approximately 20 percent of the ore. The remainder will be placed as crushed and conveyor-stacked ore or ROM ore in the future. Crushed ore processing will involve ore passing through a single stage of crushing. ROM ores will be directly stacked by truck onto the leach pad. The processing facilities can accommodate a leachable reserve of approximately 15.6 Mt of ore at a gold grade of

0.025 oz/t and a process rate of 7,900 tpd. The new heap leach pad has been located and designed with expandability for an ore reserve increase.

Over the life of the mine, ore to be crushed will be delivered to the heap leach pad from each of the open pits and placed in the stockpile adjacent to the crushing plant. The ore will be fed to the crushing plant using a front-end loader, and will be crushed, and then transported to the heap leach pad via an overland conveyor. The ore will be stacked onto the heap using a radial stacker. Crushed and ROM ores will then be leached with a weak cyanide solution to extract the precious metal values. The gold will then be recovered from the pregnant solution in the carbon plant by adsorbing the dissolved gold onto activated carbon followed by desorption, electrowinning, retorting and smelting to recover the gold as a final doré product.

### **1.11 PROJECT INFRASTRUCTURE**

Primary access to the Project site is via US Highway 50, 25 miles west from Eureka, NV, the nearest town, or 45 miles east on US Highway 50 from Austin, NV to the Three Bars Road. Travel is then 16 miles north on the Three Bars Road, a gravel, all weather road maintained by Eureka County.

Three natural gas generators will be used to supply power to the crushing, screening, processing loads and supporting infrastructure.

The peak make-up water requirement for the Project is 450 gpm. The water source for the Project will be from production wells located approximately 2 miles southeast from the site and will be powered by a separate diesel generator.

### **1.12 ENVIRONMENTAL STUDIES AND PERMITTING**

Gold Bar North is fully permitted for operations within the Pick and Ridge pits and for processing operations.

In order to bring Gold Bar South into operations, an amended Mine Plan of Operations (MPO) was developed to incorporate the proposed expansion of mining operations into the Gold Bar South (GBS) area. The MPO envisions mining from open pits in the GBS area, a haul road to allow ore transport to the existing Gold Bar heap leach pad, waste rock dumps and associated EPMS to protect the environment. This MPO was submitted to the Bureau of Land Management September 25, 2020. A Record of Decision is expected in Q1 2022.

Additional state and federal permits will be required to be amended to permit operations in the GBS area. No significant social or community issues exist currently at the Gold Bar Project or are expected to impact the development of the Gold Bar South addition to the project.

### **1.13 CAPITAL AND OPERATING COSTS**

McEwen began construction on Gold Bar in November 2017 and plant commissioning was completed in Q1 2019. Life of mine sustaining capital projections total \$19.5M consisting of \$10.9M for leach pad expansion, \$3.0M for Gold Bar South construction and \$5.6M for other sustaining capital.

Reclamation costs are estimated based on the Nevada Standardized Reclamation Cost Estimator (SRCE) and standardized cost data. The total reclamation cost is included for the closure and reclamation of the existing mining operations as well as the yet to be developed Gold Bar South operations. The total reclamation cost is estimated at \$16.9M.

Table 1-9 shows the estimated life of mine on-site operating cost by area per ton of ore processed and per ounce produced.

**Table 1-9: LOM Site Operating Cost Summary**

|   | <b>Cost per Ton of Ore Processed</b> | <b>Cost per Ounce Produced</b> |
|---|--------------------------------------|--------------------------------|
| Mining  | \$13.14                              | \$769                          |
| Process   | \$4.09                               | \$239                          |
| G&A   | \$3.23                               | \$189                          |
| <b>Total Site Operating Cost <sup>(1)</sup></b> | <b>\$20.46</b>                       | <b>\$1,197</b>                 |

Notes:

1. Site operating cost is calculated by dividing total life-of-mine on-site production costs by total ounces produced.

## **2 INTRODUCTION**

### **2.1 DETAILS OF REGISTRANT**

McEwen Mining Inc. (McEwen) is the owner of the Gold Bar Project. The Project is located in the town of Eureka in Eureka County, Nevada.

McEwen Mining Inc. is registered in the state of Colorado, in the United States and is listed on the NYSE and TSX under the symbol, "MUX".

Additional information is shown in Table 2-1:

**Table 2-1: Identification of the Issuer**

| <b>Data</b>       | <b>Description</b>  |
|-------------------|---|
| Company Name      | McEwen Mining Inc.  |
| Financial Address | 150 King Street West Suite 2800<br>Toronto, ON M5H 1J9<br>Canada      |
| Telephone/Fax     | 647-258-0395 / 647-258-0408   |
| Website           | <a href="http://www.mcewenmining.com">http://www.mcewenmining.com</a> |
| Representative    | Mihaela Iancu, Investor Relations                                     |

This report provides updated mineral resource and mineral reserve estimates, and a classification of resources and reserves prepared in accordance with regulation S-K §229.1304 of the United States Securities and Exchange Commission ("SEC") and the Canadian Institute of Mining, Metallurgy and Petroleum (CIM) Standards on Mineral Resources and Reserves: Definitions and Guidelines.

Construction was completed in Q1 2019. At the time of this report, the plant has been in operation for approximately three years.

### **2.2 UNITS OF MEASURE**

The US System for weights and units has been used throughout this report. Tons are reported in short tons (2,000 lb). All currency is in U.S. dollars (US\$) unless otherwise stated.

### **2.3 TERMS OF REFERENCE**

The abbreviations and terms of reference used in this Technical Report are as shown in Table 2-2.

**Table 2-2: Abbreviations and Terms of Reference**

| <b>Abbreviation</b> | <b>Term</b>                                | <b>Abbreviation</b> | <b>Term</b>                           |
|---------------------|--|---------------------|---------------------------------------|
| \$                  | United States Dollars                      | ALS                 | ALS Minerals Laboratory               |
| \$USD               | United States Dollars                      | Amselco             | American Selco, Inc.                  |
| %                   | Percent                                    | amsl                | Above mean sea level                  |
| '                   | Foot or feet                               | AMT                 | Alternative minimum tax               |
| ABA                 | Acid-Base Accounting                       | ANFO                | ammonium nitrate/fuel oil             |
| ADR                 | adsorption, desorption, recovery (process) | ARDML               | Acid Rock Drainage and Metal Leaching |
| Ag                  | Silver                                     | Atlas               | Atlas Corporation                     |

**GOLD BAR PROJECT  
S-K 1300 TECHNICAL REPORT SUMMARY**

| Abbreviation  | Term  |
|---------------|---|
| Au            | Gold  |
| AuEq          | Gold equivalent   |
| BAPC          | Bureau of Air Pollution Control                         |
| BLM           | Bureau of Land Management                               |
| BMRR          | Bureau of Mining Regulation and Reclamation             |
| BV            | Bureau Veritas  |
| Cabin         | Cabin Creek (pits)                                      |
| Castleworth   | Castleworth Ventures Inc.                               |
| CIC           | carbon-in-column  |
| CIM           | Canadian Institute of Mining, Metallurgy, and Petroleum |
| cm            | Centimeter(s)   |
| CN            | Cyanide-soluble   |
| CoG           | Cut-off grade   |
| Cominco       | Cominco American Inc.                                   |
| CRM           | Certified Reference Material                            |
| C.P.G         | Certified Professional Geologist                        |
| cu yd         | Cubic yard(s)   |
| CuFt          | Cubic feet  |
| deg           | Degree(s)   |
| EIS           | Environmental Impact Statement                          |
| EIS           | Environmental Impact Statement                          |
| EW            | electrowinning  |
| FA            | fire assay  |
| FA-AAS        | fire assay- atomic absorption spectrometry              |
| Fischer-Watt  | Fischer-Watt Gold Company, Inc.                         |
| FOS           | factors of safety                                       |
| ft            | Feet  |
| g             | Gram(s)   |
| G&A           | General and administrative (costs)                      |
| gal           | Gallon(s)   |
| GBN           | Gold Bar North  |
| GBP           | Gold Bar Project  |
| GBS           | Gold Bar South  |
| Gold Bar      | The Gold Bar Project                                    |
| Gold Standard | Gold Standard Royalty (Nevada) Inc.                     |
| gpm           | Gallons per minute                                      |
| Great Basin   | Great Basin Exploration and Mining, Inc.                |
| HDPE          | high-density polyethylene                               |
| Hecla         | Hecla Mining Company                                    |
| HP            | Horsepower  |
| IDW           | Inverse Distance Squared                                |
| IMC           | Independent Mining Consultants                          |
| in            | Inch(es)  |
| IRR           | Internal Rate of Return                                 |
| KCA           | Kappes Cassiday and Associates                          |
| kg            | Kilogram(s)   |

| Abbreviation | Term   |
|--------------|--|
| koz          | Thousand ounces                                    |
| kt           | thousand short tons                                |
| ktons        | thousand short tons                                |
| kW           | Kilowatt   |
| kWh          | Kilowatt hour                                      |
| lbs          | Pounds   |
| LCRS         | leak collection and recovery system                |
| LFC Trust    | Lyle F. Campbell Trust                             |
| LG           | Lerchs-Grossmann                                   |
| LiDAR        | Light Detection and Ranging                        |
| LNG          | Liquid natural gas                                 |
| LOM          | Life of mine                                       |
| m            | Meter(s)   |
| MDL          | Method Detection Limit                             |
| MEG          | Mineral Exploration and Environmental Geochemistry |
| mgal         | Million gallons                                    |
| McEwen       | McEwen Mining Inc.                                 |
| MOU          | Memorandum of Understanding                        |
| MPO          | Mine Plan of Operations                            |
| MRDI         | Mineral Resources Development Inc.                 |
| MRE          | Mineral Resource Estimation                        |
| Mt           | Million short tons                                 |
| NDEP         | Nevada Division of Environmental Protection        |
| NDOT         | Nevada Departments of Transportation               |
| NDOW         | Nevada Department of Wildlife                      |
| NDWR         | Nevada Division of Water Resources                 |
| NEPA         | National Environmental Policy Act                  |
| NI 43-101    | National Instrument 43-101                         |
| NN           | Nearest neighbor                                   |
| NPI          | Net profits interest                               |
| NPV          | Net Present Value                                  |
| NSR          | Net Smelter Returns                                |
| °            | Degree(s)  |
| O&M          | Operations and Maintenance                         |
| OK           | ordinary kriging                                   |
| OMPC         | ore mining and processing cost                     |
| opt          | Ounce per ton                                      |
| ORK          | Outlier Restricted Kriging                         |
| oz           | Troy Ounce   |
| pcf          | Pounds per cubic foot                              |
| pers. comm.  | Personal communication                             |
| PFS          | Pre-Feasibility Study                              |
| Phelps Dodge | Phelps Dodge Mining Company                        |
| Phillips     | Phillips Enterprises                               |
| Pick         | Gold Pick (pit)                                    |
| ppm          | Parts per million                                  |

**GOLD BAR PROJECT  
S-K 1300 TECHNICAL REPORT SUMMARY**

| Abbreviation | Term  |
|--------------|---|
| PRD          | Percent Relative Difference   |
| Project      | The Gold Bar Project  |
| PSHA         | Probabilistic Seismic Hazard Analysis                                       |
| psi          | Pounds per square inch  |
| QA/QC        | Quality Assurance/Quality Control   |
| QP           | Qualified Person  |
| RC           | Reverse circulation (drill hole type)                                       |
| Ridge        | Gold Ridge (pit)  |
| RMT          | Roberts Mountain Thrust   |
| RpD          | Record of Decision  |
| ROM          | Run of Mine   |
| s            | Second(s)   |
| S-K 1300     | Subpart 1300 of Regulation S-K of the US Securities and Exchange Commission |
| Santa Fe     | Santa Fe Mining, Inc.   |
| SRCE         | Standardized Reclamation Cost Estimator                                     |

| Abbreviation     | Term  |
|------------------|---|
| SRK              | SRK Consulting (U.S.), Inc.   |
| st               | Short ton   |
| t                | Short ton(s)  |
| Technical Report | Gold Bar Project Form S-K 1300 Technical Report – Feasibility Study |
| ton              | Short ton   |
| Tonne            | Metric ton  |
| tpd              | Short tons per day  |
| tph              | Short tons per hour   |
| US\$             | United States Dollars   |
| USDOT            | U.S. Department of Transportation                                   |
| V                | Volt(s)   |
| Westley          | Westley Explorations Inc.   |
| WPCP             | Water Pollution Control Permit                                      |
| WRD              | Waste rock disposal area  |
| WRMP             | waste rock management plan  |
| yd               | Yard  |
| yr               | Year  |

## 2.4 CAUTIONARY STATEMENTS

### 2.4.1 Forward Looking Information

This report contains “forward-looking information” or “forward-looking statements” that involve a number of risks and uncertainties. Forward-looking information and forward-looking statements include, but are not limited to, statements with respect to the future prices of gold, the estimation of mineral resources and reserves, the realisation of mineral estimates, the timing and amount of estimated future production, costs of production, capital expenditures, costs (including capital costs, operating costs, cash cost per ounce (oz) and other costs) and timing of the development of new mineral deposits, permitting timelines, LOM, rates of production, annual revenues, IRR, NPV, currency fluctuations, requirements for additional capital, government regulation of mining operations, environmental risks, unanticipated reclamation expenses, title disputes or claims, limitations on insurance coverage and timing and possible outcome of pending litigation.

Often, but not always, forward-looking statements can be identified by the use of words such as “plans”, “expects”, or “does not expect”, “is expected”, “budget”, “scheduled”, “estimates”, “forecasts”, “intends”, “anticipates”, or “does not anticipate”, or “believes”, or variations of such words and phrases or state that certain actions, events or results “may”, “could”, “would”, “might” or “will” be taken, occur or be achieved.

Forward-looking statements are based on the opinions, estimates and assumptions of contributors to this report. Certain key assumptions are discussed in more detail. Forward looking statements involve known and unknown risks, uncertainties and other factors which may cause the actual results, performance or achievements of McEwen to be materially different from any other future results, performance or achievements expressed or implied by the forward-looking statements.

Such factors include, among others: the actual results of current development activities; conclusions of economic evaluations; changes in project parameters as plans continue to be refined; future prices of silver and gold and other

metals; possible variations in ore grade or recovery rates; failure of plant, equipment or processes to operate as anticipated; accidents, labour disputes and other risks of the mining industry delays in obtaining governmental approvals or financing or in the completion of development or construction activities; shortages of labour and materials, the impact on the supply chain and other complications associated with pandemics, including the COVID-19 (coronavirus) pandemic; as well as those risk factors discussed or referred to in this report and in McEwen's documents filed from time to time with the securities regulatory authorities in the United States and Canada.

There may be other factors than those identified that could cause actual actions, events, or results to differ materially from those described in forward-looking statements, there may be other factors that cause actions, events or results not to be anticipated, estimated or intended. There can be no assurance that forward-looking statements will prove to be accurate, as actual results and future events could differ materially from those anticipated in such statements. Accordingly, readers are cautioned not to place undue reliance on forward-looking statements. Unless required by securities laws, the authors undertake no obligation to update the forward-looking statements if circumstances or opinions should change.

## **2.4.2 Non-GAAP Measures**

This report contains certain non-GAAP (Generally Accepted Accounting Principles) measures such as cash cost and ASIC. Such measures have non-standardised meaning under GAAP and may not be comparable to similar measures used by other issuers. See McEwen's latest Management's Discussion and Analysis for more information about non-GAAP measures reported by McEwen.

## **2.5 SOURCE OF INFORMATION**

The parties responsible for generating this technical report summary included Gingerquill Consulting LLC (Gingerquill), M3 Engineering & Technology Corporation (M3), McEwen Mining Inc. (McEwen), Independent Mining Consultants, Inc. (IMC), and Forte Dynamics (Forte Dynamics). A legal opinion on land ownership and mineral title ownership was supplied by the registrant from the law firm of Erwin Thompson Faillers.

## **2.6 QP DETAILS AND SITE VISIT**

### **2.6.1 QP Details**

Qualified Persons' responsibilities on a per-section basis were as shown in Table 2-3.

**Table 2-3: Responsibilities and Sources of Information**

| <b>Responsible Party</b>                | <b>Abbreviation</b> | <b>Section Responsibility</b>  |
|---|---------------------|--|
| Gingerquill Consulting LLC              | Gingerquill         | Sections 1, 15, 16, 18.1, 18.2, 20, and corresponding subsections of 22, 23, and 24. |
| M3 Engineering & Technology Corporation | M3                  | Sections 2, 21 and 25.   |
| McEwen Mining Inc.<br>Kevin Kunkel CPG  | McEwen              | Sections 3, 4, 5, 6, 7, 8, 17 and corresponding subsections of 1, 22, 23, and 24.    |
| McEwen Mining Inc.<br>Michael Baumann   | McEwen              | Sections: 9 and 11 and corresponding subsections of 1, 22, and 23                    |
| Independent Mining Consultants, Inc.    | IMC                 | Sections 12, 13, 18.3, and corresponding subsections of 1, 19, 22, 23, and 24.       |
| Forte Dynamics                          | Forte Dynamics      | Sections 10, 14, and corresponding subsections of 1, 21, 22, 23, and 24.             |



**2.6.2 Site Visit**

M3 visited the project site on January 19, 2017 and September 12, 2019, McEwen Michael Bauman, visited the project site on February 14, 2021 and McEwen Kevin Kunkel CPG visited the project site on February 18, 2021, IMC visited the project site on October 14, 2019, and Forte Dynamics visited the project site on November 3, 2020.

### **3 PROPERTY DESCRIPTION AND OWNERSHIP**

This section addresses the Project land holdings, corporate agreements, existing environmental liabilities, and the permitting process.

#### **3.1 PROPERTY LOCATION**

The Project is located in the southern Roberts Mountains, approximately 30 miles northwest of the town of Eureka in Eureka County, Nevada. It includes the Gold Bar North (GBN) deposits, previously reported as the Gold Bar Project, as well as the Gold Bar South (GBS) satellite deposits. A project location map is shown in Figure 3-1. The Project is located within all or portions of the following Townships, Ranges, and Sections relative to the Mount Diablo Baseline and Meridian:

- Township 21 North, Range 50 East, Sections 02, 03, 04, 05, 09, 10, 11;
- Township 22 North, Range 49 East, Sections 1, 2, 11, 12, 13, 14, 15, 16, 20, 21, 22, 23, 24, 25, 26, 27, 28, 34, 35, 36;
- Township 22 North, Range 50 East, Sections 01, 02, 03, 04, 05, 06, 07, 08, 09, 10, 11, 12, 13, 14, 15, 16, 17, 18, 19, 20, 21, 22, 23, 24, 25, 26, 27, 28, 29, 30, 31, 32, 33, 34, 35, 36;
- Township 22 North, Range 51 East, Sections 04, 05, 06, 07, 08, 09, 10, 15, 16, 17, 18, 19, 20, 21, 28, 29, 30, 31, 32, 33;
- Township 23 North, Range 49 East, Sections 13, 14, 15, 22, 23, 24, 25, 26, 27, 34, 35, 36;
- Township 23 North, Range 50 East, Sections 09, 10, 14, 15, 16, 19, 20, 21, 22, 23, 25, 26, 27, 28, 29, 30, 31, 32, 33, 34, 35, 36; and,
- Township 23 North, Range 51 East, Sections 30, 31, 32.

The approximate centroid of the north deposit areas is N39.80°, W116.34°. GBS is centered at approximately N39.76°, W116.27°. The Project has good connections to the infrastructure of northern Nevada, with public roads linking to a haul road that connects the former Atlas Gold Bar plant location to GBN. GBS is accessible from improved and unimproved public roads. The climate of the Project area is characterized as high mountain desert with cold winters and warm summers. Project elevations range from 6,500 ft to 9,063 ft.



Figure 3-1: Location Map

**3.2 MINERAL TITLES**

**3.2.1 Project Area**

The Project covers approximately 56,800 acres. This area consists of 2,808 unpatented mining claims. Unpatented claims are on land owned by the U.S. government, and administered by the U.S. Department of the Interior, Bureau of Land Management (BLM). There are 22 patented claims owned by McEwen Mining Nevada, Inc. including 10 patented WI claims owned by Golden Pick, LLC, which is, in turn, owned by McEwen Mining Nevada, Inc., six patented WAH lode claims, and six patented AM mill site claims. The property outline of the Project area is shown in Figure 3-2. A summary of the controlling entities of the Project Area claims shown on the map in Figure 3-3 and Figure 3-4, is in Table 3-1. A list of all claims staked within the Project boundary by McEwen, its entities, or partners, is shown in Appendix A and is current as of December 2020.

**Table 3-1: Gold Bar Claims Summary**

| <b>Patented Claims</b>              | <b>Number</b> |
|-------------------------------------|---------------|
| APN 009-160-01: WI lode claims      | 10            |
| APN 009-180-01: AM mill site claims | 6             |
| APN 009-180-02: WAH claims          | 6             |
| <b>Unpatented Claims</b>            |               |
| <b>Entity</b>                       | <b>Number</b> |
| Golden Pick LLC                     | 837           |
| McEwen Mining Nevada Inc.           | 1142          |
| WKGUS LLC                           | 829           |
| <b>Total</b>                        | <b>2808</b>   |

Source: McEwen, 2018

McEwen, through its wholly owned subsidiaries McEwen Mining Nevada Inc., WKGUS LLC, and Golden Pick LLC, controls 2,808 unpatented lode mining claims and one parcel of privately owned land in the Project area. The parcel consists of 10 patented lode claims (WI lode claims), which cover most of the Gold Pick and Gold Ridge resource area and was part of Atlas' original land holdings. The 6 patented lode claims and 6 patented mill site claims at the original Gold Bar site were also part of Atlas's original land holdings. Royalties on the Project Area are discussed in Section 3.3 below as they apply to various claims.

**3.2.2 Gold Bar North**

The GBN project area, defined here as the Mine Plan of Operations Permit Area, covers approximately 5,264 acres, containing a block of 308 unpatented mining claims and 22 patented claims. This project area includes the gold deposits that are currently being mined, such as Cabin Creek, Gold Pick, and Gold Ridge, as well as historically mined deposits.

To the best of McEwen's knowledge, all mining claims have been validly located, recorded, filed, and maintained in accordance with all Applicable Laws and are valid.

**3.2.3 Gold Bar South**

The GBS project area, defined by the proposed Mine Plan of Operations area, covers approximately 2,230 acres, within a continuous block of 188 unpatented mining claims. All unpatented mining claims are held by McEwen Mining

Nevada, Inc. and are subject to a royalty as discussed in Section 3.3. McEwen has initiated permitting procedures for mining at Gold Bar South.

To the best of McEwen's knowledge, all mining claims have been validly located, recorded, filed, and maintained in accordance with all Applicable Laws and are valid.

### **3.2.4 Surface Rights**

McEwen, through its wholly owned subsidiary Golden Pick LLC, owns both the surface and mineral rights to the 10 patented WI claims and has the right to use the surface for mining and exploration purposes. This private parcel covers most of the known extent of the Gold Pick mineral resource and the Gold Ridge North mineral resource.

McEwen Mining Nevada Inc. owns both the surface and mineral rights to the 6 patented WAH and 6 patented AM claims and has the right to use the surface for mining and exploration purposes. These private parcels are at the location of the former Atlas Gold Bar plant site.

Use of the surface of the unpatented lode claims is subject to a permitting process with the BLM and the State of Nevada. Exploration work that meets the definition of "casual use" as stated in 43 CFR 3809.5 (1) can be freely undertaken. Exploration work such as drilling that involves surface disturbance requires a permit and the posting of a bond. The approved Gold Bar Mine Plan of Operations includes 65.1 acres of exploration disturbance to support these continued activities.

### **3.2.5 Patented Claims**

McEwen, through its wholly owned subsidiary Golden Pick LLC, owns 10 patented WI lode mining claims in the GBN area. The patented claims encompass approximately 192 acres and have been consolidated into one taxable parcel as Eureka County Assessor's Parcel Number 009-160-01.

McEwen Mining Nevada Inc. owns 6 patented lode mining claims and 6 patented mill site claims in the McEwen Project Area. The patented claims encompass approximately 53 acres in Eureka County Assessor's Parcel Numbers, 009-180-01 and 009-180-02.

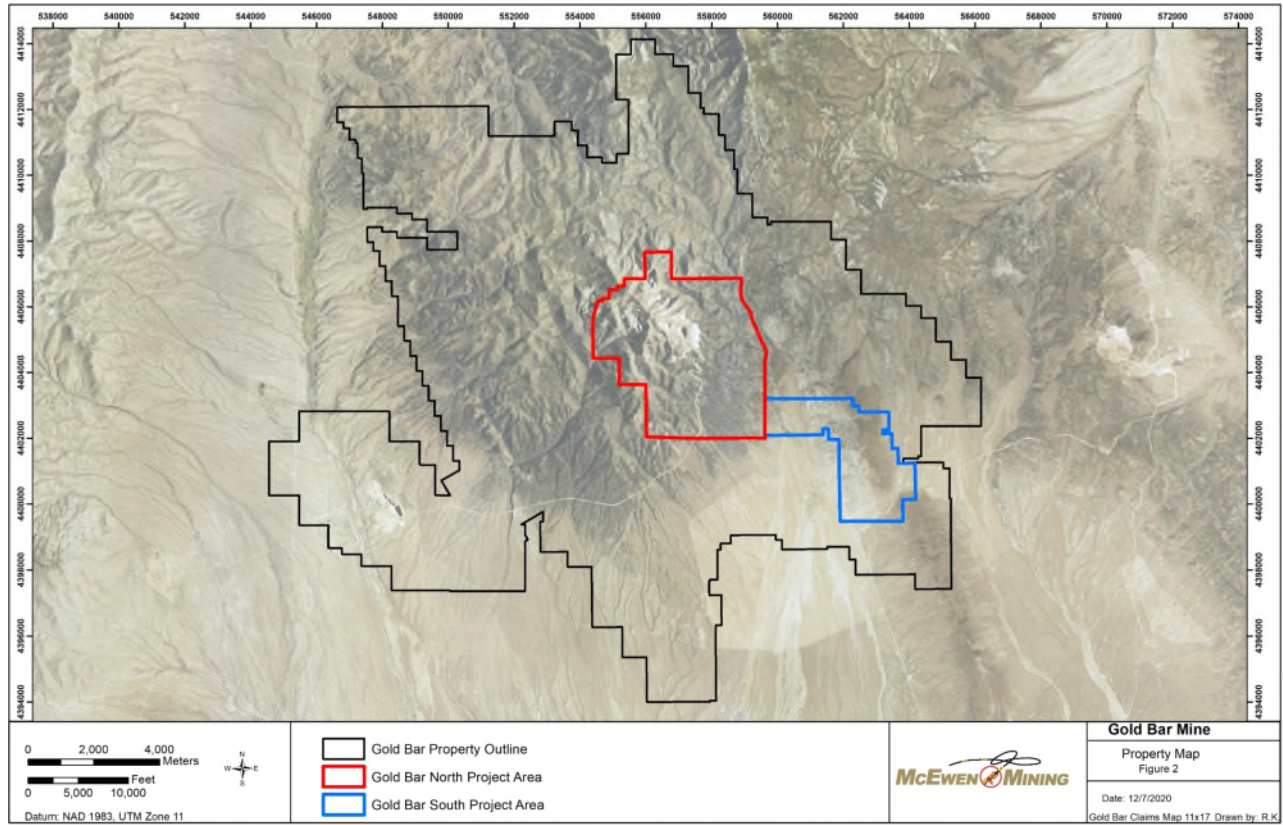


Figure 3-2: Gold Bar Property Map

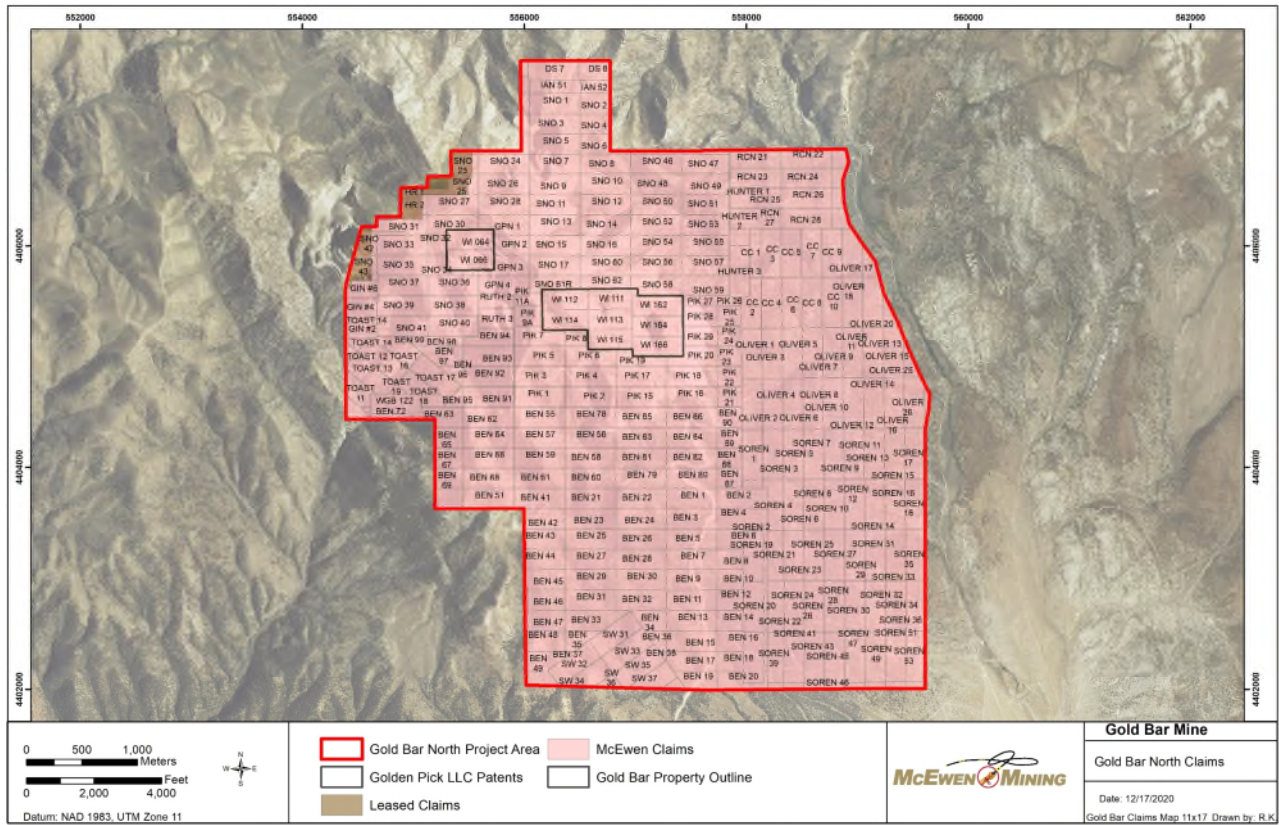


Figure 3-3: Gold Bar North Project Area Claims Map

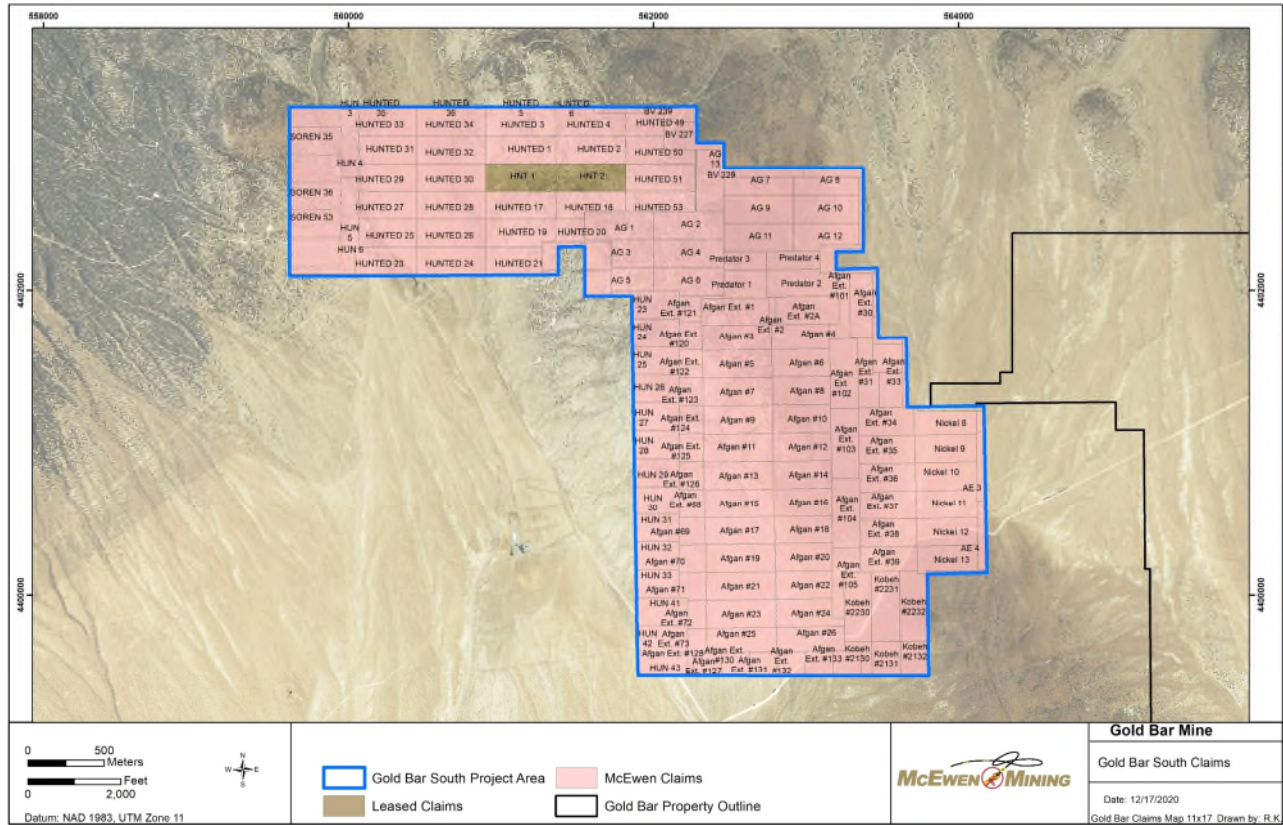


Figure 3-4: Gold Bar South Project Area Claims Map

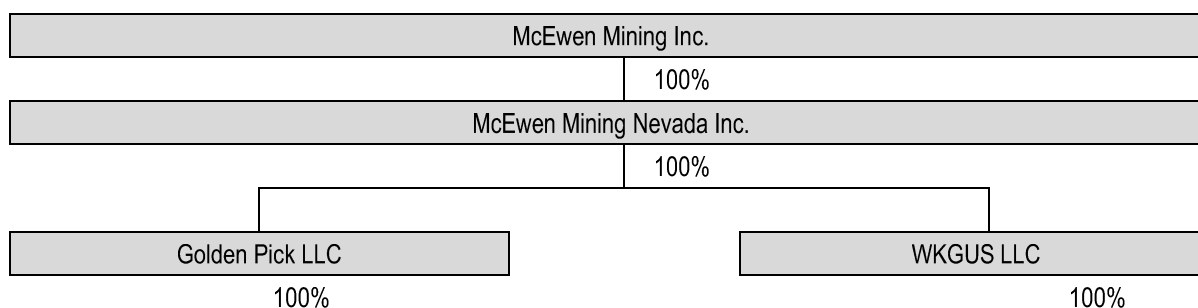


**3.2.6 Nature and Extent of Issuer’s Interest**

McEwen, through its wholly-owned subsidiary Golden Pick LLC, owns both the surface and mineral rights to Eureka County APN 009-160-01, which covers the 10 patented WI lode claims at Gold Pick and Gold Ridge, and has the right to use the surface for mining and exploration purposes. McEwen controls 2,808 unpatented lode mining claims in the Gold Bar District, of which 308 are in the permitted GBN area, plus an additional 188 in the GBS claim block. The Project area is accessible from public roads maintained by Eureka County. Current access routes are legally accessible, crossing both publicly- and privately-owned land.

McEwen’s property interest relevant to the Project is depicted in Table 3-2.

**Table 3-2: Corporate Structure**



Obligations that must be met to retain the property include the payment of annual maintenance fees to the BLM (Federal level) of US\$165 per claim per year, and fees of US\$12 per claim per year plus an additional document fee determined by the County (County/State level). These rates are current as of 2020 and may change over time. Property taxes are paid to Eureka County on the private parcels. Other payments included obtaining and maintaining all necessary regulatory permits, as well as lease payments to the owners of claims held under lease agreement. The rights to unpatented lode claims continue on an annual basis so long as all obligations are met to maintain the claims in good standing. Maintenance fees have been timely paid by McEwen Mining Nevada Inc., WKGUS LLC, and Golden Pick LLC to both the BLM and the County for unpatented lode mining claims covered by the Project for the assessment year 2020-2021. Eureka County property taxes for APN 009-160-01, 009-180-01, 009-180-02 are current.

**3.3 ROYALTIES, AGREEMENTS AND ENCUMBRANCES**

The following list is a list of royalties attached to claim groups on the Gold Bar property:

1. **Project, Scoonover Exploration:** A mineral production royalty of 1% payable to Scoonover under the Special Warranty Deed with Reserved Royalty dated July 31, 2015, recorded in the Office of the Eureka County Recorder on August 7, 2015, Document 229735. The royalty affects the DS and GM mining claims.
2. **Project, CC claims:** 10% of Net Profits to Premier Royalty USA.
3. **Project, NH and SW claims:** 8% of Net Profits to Teck American.
4. **Project, David Knight Trust:**
  - a. 1% NSR on the CC claims.
  - b. 1% NSR on the NH and SW claims.

- c. Bolivar: 3% NSR on WFWKV and TAZ claims from Knight Trust Mining Lease Option, Kinross Purchase and Sale Agreement, Kinross Royalty Deed, Assignment and Assumption between Kinross and McEwen Doc #2019-239683.
5. **Project - Bolivar, Larry McMaster:** 1.5% NSR on GAP claims from McMaster Mining Lease Option, Kinross Purchase and Sale Agreement, Kinross Royalty Deed, Assignment and Assumption between Kinross and McEwen Doc #2019-239682.
6. **Project – Bolivar, Kinross:**
  - a. 1% NSR on WFWKV and TAZ claims from Knight Trust Mining Lease Option, Kinross Purchase and Sale Agreement, Kinross Royalty Deed, Assignment and Assumption between Kinross and McEwen Doc #2019-239683
  - b. 1% NSR on GAP claims from McMaster Mining Lease Option, Kinross Purchase and Sale Agreement, Kinross Royalty Deed, Assignment and Assumption between Kinross and McEwen Doc #2019-239682
  - c. 2% NSR on all BV, BVN and BVNR claims from Royalty Deed Doc #2019-239445.
7. **Gold Bar South Project – HNT Leased claims:**
  - a. 2% NSR on gold and 1.5% NSR on any other minerals to Nevada Select Royalty.
8. **Project – JAM Leased claims:**
  - a. 2% NSR on gold and 1.5% NSR on any other minerals to Nevada Select Royalty.
  - b. 4% NSR on production between 50,001 oz. and 150,000 oz of gold produced, reserved to NERCO, assigned to Ivanhoe Investment Corp.
9. **Gold Bar South Project:**
  - a. 1% NSR to Bronco Creek Exploration on AFGAN, AFGAN EXT., PREDATOR, NICKEL, AG and AE claims: Gold Standard Royalty (Nevada) Inc. (merged into Nevada Royalty Corp.) under the Quitclaim Deed with Reservation of Royalty dated effective June 14, 2010, recorded in the Office of the Eureka County Recorder on July 5, 2011, Document 217713. Record title to the royalty is held by Bronco Exploration, Inc., an Arizona corporation.
  - b. 1% NSR to Nevada Royalty Corp. on KOBEL claims.
  - c. A 1% “undocumented” NSR on KOBEL claims as noted in the Gold Standard Royalty Agreement dated 5/14/2010.
10. **Gold Bar – Haul Road:** 1.5% NSR on the MANY claims to Ivy Minerals Inc. by Royalty Deed, Doc. # 2019-239354.
11. **Gold Bar – Gold Canyon:** 2% NSR to Nevada Select Royalty on the GOLD RIDGE and GCN-30 claims, upon completing the Option to Purchase, Option to expire 12/29/2022.
12. **Gold Bar – Old Gold Bar:** 2% NSR to Nevada Select Royalty on the GB, GOLDBAR, GF unpatented claims, AM and WAH patented claims by Royalty Deed Doc. #2020-240246 and #2020-240247.

13. **Gold Bar – WW claims acquisition:** 1% NSR to Eureka Moly LLC on the WW claims by Royalty Deed Doc. 2020-241926.

McEwen's Gold Bar Mine is subject to the Nevada Net Proceeds of Minerals tax, Nevada Excise tax, Nevada property and sales taxes, and U.S. income taxes. McEwen has a large Loss Carried Forward (US\$100.5 million) that is applied to this Project. The net effect of this carried loss is that the Project does not pay Federal income taxes during the life of the operation. However, an alternative minimum tax (AMT) of US\$1.6 million is expected to be paid during life of the Project.

The Net Proceeds of Minerals tax is an "ad valorem property tax assessed on minerals when they are sold or removed from Nevada. The tax is levied on 100% of the value of the net proceeds (gross proceeds minus allowable deductions for tax purposes)." Calculation of this tax was made at 5%, the current rate if proceeds are greater than US\$4 million. Federal Income tax has been applied at 35%, allowing for depletion, depreciation, and amortization as calculated under the Federal rules for alternative minimum tax.

### **3.4 ENVIRONMENTAL LIABILITIES AND PERMITTING**

#### **3.4.1 Environmental Liabilities**

Previous mining at the GBN was conducted by Atlas and included the construction of open pits and waste rock dumps. The ore from the Gold Pick and Gold Ridge pits was processed at the Atlas plant facility, which was located approximately 11 miles from the current Project area. The plant at the original site is in the process of being dismantled by the owner of the physical assets. The tailings storage facility that is adjacent to the plant has been reclaimed by the BLM.

In November 2005, the BLM conducted limited reclamation of the Atlas waste rock dumps in the area of the Gold Pick pit. These activities were apparently funded through bonding forfeiture by Atlas. Much of the pre-existing Atlas mining disturbance was incorporated into the McEwen Mine Plan of Operations. Those areas that are directly used and those areas that are partially used have been included in the McEwen reclamation plan.

#### **3.4.2 Required Permits and Status**

The Project is located approximately 30 miles northwest of the town of Eureka, in the southern Roberts Mountains of Eureka County, Nevada. The location and current land ownership position (i.e., both private and public land ownership) mean that the mine will be held to permitting requirements that are determined to be necessary by Eureka County, the State of Nevada, and the U.S. Department of the Interior, Bureau of Land Management, Battle Mountain District Office, Mt. Lewis Field Office (BLM).

A comprehensive list of the required federal, state, and local permits, licenses, and authorizations for the Gold Bar Mine are presented in Section 17 of this report. The BLM 43 CFR § 3809 Mine Plan of Operations and State of Nevada, Department of Conservation and Natural Resources, Division of Environmental Protection, Bureau of Mining Regulation and Reclamation (BMRR) NAC 519A Reclamation Permits have been approved. A RoD was issued on November 7, 2017. Several amendments have been requested and approved. The BMRR approved the Reclamation Permit on October 18, 2017, revised May 14, 2019.

Another principal permit for mining operations in Nevada is the BMRR Water Pollution Control Permit (WPCP), which was issued on October 11, 2017, revised December 21, 2018. The Permit to Appropriate Water from the Nevada Division of Water Resources (NDWR) was also approved. McEwen has the rights to 500 acre-feet per annum of water for the Project via Water Rights Permit No. 82105.

**GOLD BAR PROJECT**  
**S-K 1300 TECHNICAL REPORT SUMMARY**

---

The Gold Bar South area has been identified as an additional mineral resource, currently outside of the Gold Bar Permit Boundary. Baseline studies have been conducted and the Mine Plan of Operations has been submitted to the BLM, as of September 25, 2020. A Record of Decision is expected in the second half of 2021.

**3.5 OTHER SIGNIFICANT FACTORS AND RISKS**

Potential factors and risks that could affect access, title, or the right or ability to perform work on the property have been mitigated. These include:

- All cultural resources have been identified and 2018 construction areas have been mitigated and,
- A greater sage grouse mitigation plan was included in the RoD.

Considerable effort has been expended on conducting surface inventories within the Project boundary. For the most part, these surveys have focused on surface features and artifacts. Given the number of cultural and archeological resources in the region, it is possible for subsurface discoveries to be made during future construction of the mine facilities, but unlikely. Such a discovery would require mitigation that may impact the construction schedule of the Project.

## **4 ACCESSIBILITY, CLIMATE, LOCAL RESOURCES, INFRASTRUCTURE AND PHYSIOGRAPHY**

### **4.1 TOPOGRAPHY, ELEVATION AND VEGETATION**

Gold Bar is located in the southern Roberts Mountains, central Nevada. The Project area has steep topography and GBN is approximately 1,200 feet higher than the adjacent Kobeh Valley. GBS is at an elevation of roughly 6,900 feet. All land in the Project area is above 6,500 ft above mean sea level (amsl), and the highest point in the current land package is 9,063 ft amsl. Vegetation is dominated by pinion pine and juniper trees mixed with mountain mahogany at higher elevations, with sagebrush and grasses in the foothills and valleys.

### **4.2 ACCESSIBILITY AND TRANSPORTATION TO THE PROPERTY**

Primary light vehicle access to the Project site is 15 miles west on US Highway 50 from Eureka, NV, the nearest town. From U.S. Highway 50 travel north on Roberts Creek Road (Eureka County designation M-108), a gravel county road, for approximately 14 miles, then northwest on General County Road G-215 for approximately 2-miles to the Gold Bar Mine entrance. GBS is located approximately 14 miles north of Highway 50 via Roberts Creek Road, then east on a 0.25-mile segment on the Henderson Pass Road before turning north for 1-mile to the project core. The existing roads and other features near the Project are shown in Figure 4-1.

Heavy vehicle access to the Project site is located 25 miles west on US Highway 50 from Eureka, NV or 45 miles east on U.S. Highway 50 from Austin, NV to 3 Bar Road. Travel is then 16 miles north on 3 Bar Road, a gravel, all weather road maintained by Eureka County, and then east for 1.5 miles on General County Road G-215 to the decommissioned Atlas Mill site at the original Gold Bar Mine. The Gold Pick mine is approximately 11 miles northeast along the haul road. This primary access route is gravel and will be maintained for year-round access by McEwen. Where necessary, this road is upgraded to meet the requirements of both U.S. Department of Transportation (USDOT) and/or Nevada Department of Transportation (NDOT) and McEwen during operations.



#### **4.3 CLIMATE AND LENGTH OF OPERATING SEASON**

The Project is located in the Great Basin physiographic province, the largest North American desert, which extends east-west from western Utah to eastern California and north-south from southern Idaho to southern Nevada. Characteristic topography is elongate north-south mountain ranges separated by broad (5- to 20-mile-wide) alluvial valleys created by Tertiary extensional tectonics. Mountain ranges typically rise 3,000 to 5,000 ft above the valley floors, which are incised by shallow ephemeral drainages. The climate of the Project area is typical of a high mountain desert, with cold, snowy winters and warm, dry summers. Winter low temperatures range between about -5°F and 30°F with summertime high temperatures between about 80°F and 100°F. Precipitation averages approximately 12 inches per year, mostly in the form of winter snow. Snow accumulations vary from virtually none during dry winters to greater than three feet in wetter years. Afternoon thunderstorms during the summer also contribute to annual precipitation totals. The climate allows year-round exploration and mining activity, with adequate road maintenance.

#### **4.4 SUFFICIENCY OF SURFACE RIGHTS**

All mineralized material in the mineral resource estimate in this Report is located on patented and unpatented lode claims controlled by McEwen. As described in detail in Section 3 of this report, McEwen has secured and maintained the necessary permits for exploration, development, and operation of the Project.

#### **4.5 INFRASTRUCTURE AVAILABILITY AND SOURCES**

##### **4.5.1 Power**

The primary power supply for the operation is from McEwen-owned generators fueled by liquid natural gas (LNG). The power plant is required to supply power to water pumps, screen plant and process plant facilities. LNG is a lower cost, lower emission alternative to diesel that can be estimated accurately based on operating experience. The LNG generators are located, down-gradient from the process facility.

##### **4.5.2 Water**

The Project requires approximately 305 gpm of makeup water on average, with a peak utilization of up to 450 gpm during operations. Water is pumped to the Gold Bar Project area from wells located on adjacent private property. Pumps are powered by a diesel generator located near the pumps.

##### **4.5.3 Mining Personnel**

There is considerable expertise in mining operations and management available from population centers within a 100-mile radius of the Project. Northern Nevada is an active mining area, with emphasis on open-pit gold operations. Mining personnel are drawn from the towns of Elko, Eureka, Ely and Winnemucca, Nevada, and other smaller communities.

##### **4.5.4 Waste Disposal Areas**

The waste storage facilities are east and west of Gold Pick, west of Gold Ridge and mined-out pits. The waste storage was designed as valley fill and backfill of both historic pits and portions of the current mining areas. A detailed description of the waste storage facilities is in Section 13.

#### **4.5.5 Heap Leach Pad Areas**

The heap leach pad site and design have sufficient capacity for the current operation and potential expansion. A planned expansion is included in the cash flow model. It is also proximal to a water source and mining areas to optimize operational efficiency. Construction and operation of the heap leach pad are detailed in Section 14 of this report.

#### **4.5.6 Processing Plant Sites**

The location of the processing plant is adjacent to and down-gradient of the heap leach pad. The plant site is described in Section 14 of this report.



## **5 HISTORY**

Gold Bar exploration history began in the early 1980's with various companies conducting exploration programs in various portions of the property. McEwen acquired the property in 2007 and began an extensive exploration program leading to the resumption of mining activities.

### **5.1 PRIOR OWNERSHIP AND OWNERSHIP CHANGES**

Prior ownership and ownership changes are discussed in the Exploration and Development Results of Previous Owners section, below.

### **5.2 EXPLORATION AND DEVELOPMENT RESULTS OF PREVIOUS OWNERS**

#### **5.2.1 Gold Bar North**

Regional reconnaissance exploration led Atlas Precious Metals Inc. (Atlas) into the Eureka-Cortez area in the summer of 1983. Focused reconnaissance along the southern Roberts Mountains identified widespread hydrothermal alteration with anomalous gold geochemistry along the western range front. Detailed exploration in the area subsequently led to acquisition of land, target development, and drilling.

In the late fall of 1983, three holes were drilled in the area of the original Gold Bar pit near the existing decommissioned plant site. One hole intersected 5 feet of altered limestone that assayed 0.130 opt Au. A follow-up program commenced in the spring of 1984, which combined detailed mapping and sampling of the area with step-out drilling. The discovery of the original Gold Bar deposit was made with the 28th hole, which intersected 110 feet that averaged 0.138 opt Au starting 15 feet below surface.

From 1984 to mid-1986, approximately 300 exploration holes were drilled in the pediment and along the range front. This drilling was directed at shallow mineralization to a maximum depth of 350 feet.

Additional areas of favorable alteration containing anomalous gold and gold pathfinder elements were identified in the Gold Ridge area. During the fall of 1986, drilling intersected thin intervals of low-grade mineralization. The discovery of the Gold Ridge deposit in the spring of 1987 was made with hole 295 which intersected 120 feet of mineralization that averaged 0.066 opt Au. Delineation drilling continued through the summer of 1987.

During the fall of 1987, four exploration holes were drilled on a low priority target in the Gold Pick area. The first hole intersected 85 feet of 0.048 opt Au. Delineation drilling continued at Gold Ridge and Gold Pick through 1988 and 1989.

Cabin Creek was targeted by Exxon Minerals geologists in 1982 after sampling gold-bearing silicified outcrops. They subsequently located a large claim block and drilled 26 shallow holes (White Knight Resources, 2002); data from this drilling program are not part of the McEwen database. Nerco Exploration Company (Nerco) staked the Cabin Creek property in 1986 after the ground was dropped by Exxon Minerals, exploring it independently and under joint ventures first with American Copper and Nickel Company (ACNC) and ultimately with, Phelps Dodge Mining Company (Phelps Dodge). ACNC is credited with drilling the discovery hole in the Cabin Creek deposit (150 ft @ 0.059 opt Au). There were approximately 107 RC holes drilled between ACNC, Nerco, and Phelps Dodge resulting in a geologic resource not in compliance with NI 43-101 of 2,573,070 tons @ 0.0327 opt Au for 84,213 contained Au ounces (Nerco, 1989). In 1991 when Atlas consolidated the district land position, their primary acquisition was Nerco's Cabin Creek claim block. These historical estimates were not prepared in accordance with NI 43-101 and a qualified person has not done sufficient work to classify the historical estimate as current mineral resources or mineral reserves. McEwen is not treating these estimates as current mineral resources or mineral reserves.

## **GOLD BAR PROJECT**

### **S-K 1300 TECHNICAL REPORT SUMMARY**

---

Atlas encountered financial difficulties in 1992 and 1993, resulting in sharply reduced exploration expenditures on the Gold Bar claim block. Following a change in management in the fall of 1993, exploration was re-focused to the Gold Bar Project. During late 1993 and 1994, over 300 delineation holes were drilled at Gold Pick and Gold Ridge. Additional underground delineation drilling was conducted from drifts driven from the Gold Pick and historic Goldstone pit (located north of Pick) bottoms. No exploration was done outside the mining areas during this time.

In late 1994, Atlas accelerated the exploration of the claim block through joint venture agreements with Rayrock Yellowknife Resources Inc. (for the northern portion) and Homestake Mining Company (for the southern portion).

In the summer of 1995, exploration by Atlas on the Gold Bar horst block produced encouraging drill results near the existing plant and mine site. A down-dropped block containing the Mill Site deposit was discovered. To accelerate the delineation of the newly discovered deposit, the company entered into an exploration and development agreement with Granges, Inc.

The exploration joint venture agreements were terminated in 1995 and 1996, at which time Atlas began a search for a partner for the entire property.

In the summer of 1997, Barrick Gold Corporation (Barrick) entered into an agreement with Atlas, to purchase the Gold Bar Project. Under the agreement, Barrick purchased more than 90% of the properties and had an option to acquire the balance. The agreement contained provisions for Barrick to elect to re-convey the properties to Atlas at the end of a 2-year period. Over the next two years additional geologic and geophysical work was completed. Fifty reverse circulation (RC) holes were drilled in the Gold Bar horst, Range Front and Wall areas. Results from that work suggested that Barrick's target-size-requirements would not be met.

Atlas filed for Chapter 11 bankruptcy in September 1998. In December 1998, Atlas negotiated a Mutual Termination Agreement with Barrick. The Bankruptcy court finalized the Mutual Termination Agreement in January 1999.

Vengold (now American Bonanza Gold Mining Corp.) leased the Atlas claim block in 1999. Atlas and American Bonanza dropped the claims in the Gold Pick and Gold Ridge areas in September 2001. White Knight Gold (U.S.) Inc. located new claims covering these areas in 2002-2005. White Knight Gold also purchased an extensive database of drilling, geology, metallurgy, and reserve data, generated by Atlas, in 2004. White Knight Resources was acquired by US Gold Corporation/McEwen Mining Inc. in March 2007.

#### **5.2.2 Gold Bar South**

Gold Bar South (GBS) was previously known as the Afgan project. Hurban (1999) summarized the Afgan exploration history; much of the following information is taken from that report. Lyle Campbell originally located the Samarkand claims north of GBS in the late 1970s and optioned the claims to American Selco, Inc. (Amselco). Amselco then staked the original 73 claims of the Afgan claim block in early 1980, based on the presence of anomalous gold in samples of chert breccia. Following geologic mapping and geochemical sampling, Amselco drilled 24 conventional rotary holes in July and August of 1981 to test two areas of anomalous gold in rock and soil. Several 15- to 20-foot intercepts with gold values ranging from 0.010 to 0.032 oz/ton Au were returned associated with chert, siliceous siltstone, and jasperoid. Amselco later returned all claims to Lyle Campbell and ultimately the Lyle F. Campbell Trust (LFC Trust).

Westley Explorations Inc. (Westley) staked claims east and north of the Afgan claims in 1985 and 1986, some of which comprise the northeastern portion of the present claim block. There is no evidence that Westley completed any significant exploration work within the present limits of GBS. In 1986, Hecla Mining Company (Hecla) leased the Afgan claims from the LFC Trust and undertook an eight-hole reverse circulation (RC) drilling program. Anomalous gold was intercepted over five feet in one hole. Hecla apparently did no further work on the property. In 1988, the LFC Trust drilled 15 shallow air-track assessment holes at the Afgan property, testing soil anomalies that Amselco had identified

## **GOLD BAR PROJECT S-K 1300 TECHNICAL REPORT SUMMARY**

---

along its southernmost geochemical line. None of them penetrated through the alluvium, and they are not in the drilling database used for modeling.

In June 1988, Santa Fe Mining, Inc. (Santa Fe) staked claims adjacent to the Afgan claim block, including at least part of the Kobeh property area, and later leased the Afgan claims from the LFC Trust. Santa Fe drilled four RC holes in 1988 and 11 more in July 1989, seven of which were on the Afgan claims and the remainder at what is now the Kobeh claim block. The numbering sequence of the Santa Fe drill holes and a sketch location map of the holes attached to one of the drill logs suggest that two additional holes may have been drilled, although no geologic logs or assay certificates for these holes were found in the documents provided to MDA (2011). If the holes were indeed drilled, neither would have been within the Afgan portion of the Afgan-Kobeh project. There are 13 Santa Fe holes in the drill-hole database. In August 1989, the LFC Trust drilled five air-track holes for assessment purposes and encountered anomalous gold mineralization in the lower parts of the holes (Hall, 1989). A year later, the LFC Trust drilled four additional air-track holes to satisfy assessment requirements; Hall (1990) reported that no anomalous gold values were intersected. During the same time frame, Phelps Dodge negotiated a short-term lease with an option to purchase the Afgan project from the LFC Trust (Hurban, 1999). From December 1990 through February 1991, Phelps Dodge drilled 63 RC holes at the Afgan property immediately south of the area drilled by Amselco in 1981. These holes were designed to follow up on the mineralization identified in the 1989 assessment drilling by the LFC Trust. Five of the Phelps Dodge holes were twins of the LFC Trust's 1989 holes. The Phelps Dodge program was the largest undertaking to this point on the Afgan-Kobeh project; gold mineralization was intercepted in 55 of the 63 holes. Phelps Dodge also collected some cyanide-soluble gold assay data and conducted an estimate of the mineralization present on the project before relinquishing its interest in the property in 1991.

Great Basin Exploration and Mining, Inc. ("Great Basin") staked claims south of the Afgan claims based on the results of a regional reconnaissance program in 1991; some of these are the Kobeh portion of the current GBS property. In 1992, Great Basin negotiated an option to lease the Afgan claims and held the project through 1994 (Hurban, 1999). A regional gravity survey was conducted in 1991, and a helicopter-supported electromagnetic survey that collected magnetic, radiometric, VLF, and six-channel electromagnetic data was completed in 1992 (Koehler, 1994b). Four trenches were excavated on the Afgan claims. Great Basin then drilled six RC and nine core holes (three of which were pre-collared by rotary or RC) that tested targets developed from the results of the geophysical surveys and geologic mapping. Gold mineralization was encountered in seven of the holes. These results were interpreted by Koehler (1994b) to represent a mineralized system measuring 770 by 200 by 50 feet that was open to the northeast and southwest. Gold was intersected in what was then thought to be the Mississippian Webb Formation just above its contact with the Devonian Devils Gate Limestone (based on age dating estimated using Radiolaria protozoa in 2019 from GBN sampling, the Webb Formation was reinterpreted as the Devonian Horse Canyon Formation). The highest gold values were encountered in a matrix-supported breccia in the base of the Webb Formation (Koehler, 1994b). Great Basin re-examined work by prior companies and contracted an outside source to perform a mineral inventory calculation. After a merger of Great Basin with Fischer-Watt Gold Company, Inc. (Fischer-Watt), Fischer-Watt and Cominco American Inc. (Cominco) formed a joint venture, which was operated by Cominco, and leased the Afgan claims from the LFC Trust in 1995 and 1996. The joint venture also explored the Kobeh property, which at that time consisted of approximately 170 Kobeh claims. The joint venture completed an in-house CSAMT geophysical survey over their entire property and followed this with a three-phase 16-hole RC drilling program at the Afgan and Kobeh claims (Suda, 1997). Most of the Cominco drilling was south of the previously drilled mineralization, with a final 1,560-foot hole drilled into the mineralized area previously identified by the Phelps Dodge drilling.

When the joint venture terminated the Afgan lease, the Kobeh claims were assigned to the LFC Trust, who subsequently allowed most of the Kobeh claims to lapse. In 1999, White Knight Gold, Inc. (White Knight) negotiated a letter agreement with the LFC Trust for the Afgan-Kobeh property; at that time there were 76 claims on the Afgan property and 58 Kobeh claims. White Knight staked 19 additional claims, compiled data, and completed geologic mapping and rock chip sampling at the property. Hurban's (1999) report summarized work at the property to that date. White Knight dropped the property in early 2001 (T. Gesick, 2010, written communication). Castleworth Ventures Inc.

## **GOLD BAR PROJECT**

### **S-K 1300 TECHNICAL REPORT SUMMARY**

---

(Castleworth) acquired just the Afgan property from LFC Trust on January 7, 2003 but did no significant exploration. Castleworth contracted Mine Development Associates (MDA) to prepare a mineral resource estimate for the Afgan property, which was subsequently reported in a 2004 technical report (MDA, 2004).

Midway Gold (Midway) bought Castleworth, (renamed Pan-Nevada Gold Corporation), in 2007 and thereby acquired the Afgan property. Midway drilled four RC holes at Afgan in 2007 for a total of 1,600 feet. Their 2007 Afgan drilling was designed to test the deposit margins and extensions of higher-grade gold along fault zones (Midway, 2008a). In addition, Midway collected and analyzed 17 surface rock samples, which were sent to ALS Minerals (ALS) in Elko for sample preparation followed by multi-element analyses at their labs in Sparks, Nevada, and Vancouver (Midway, 2008b).

In 2008, Midway undertook a campaign to expand known exploration areas, including collection and analysis of 297 soil samples along the eastern and northern margins of the property and ground magnetic and gravity surveying (Midway, 2009). The purpose of the soil sampling was to determine if mineralization trends could be tracked in association with the Tertiary volcanic margin. Multi-element and gold analyses were performed by ALS in Sparks, Nevada. The gravity and ground magnetic surveys were conducted by Magee Geophysical Services LLC from Reno, Nevada (Wright, 2008a, 2008b). The purpose of the ground magnetic survey was to determine the relationship of the Northern Nevada Rift to the known gold mineralization; lines were oriented east-west, spaced at 50 meters (164 feet) (Wright, 2008b). The magnetic survey covered a total of 74 line-kilometers (46 miles). The results of the ground magnetic survey were interpreted to represent a complex structural setting dominated by regional northeast-trending structures with oblique movement. The purpose of the gravity survey was to map depth of basin fill and, to a lesser extent, structures/lithologies. Four east- to northeast-trending profiles crossed the property with gravity stations surveyed at 600-meter (1,979 foot) intervals and infill stations surveyed at 200-meter (650 foot) intervals for a total of 494 stations (Wright, 2008a). Midway dropped the Afgan property in 2008.

Gold Standard Royalty (Nevada) Inc. (Gold Standard) purchased all the properties in the LFC Trust in 2007. When Midway dropped the Afgan property, the property reverted to Gold Standard. NV Gold purchased both the Afgan and the Kobeh properties from Gold Standard in 2010.

NV Gold executed a RC drilling program in both 2010 and 2011. Results from the 2010 program were applied to the 2011 MRE, as reported below in Section 5.3.2. Results from the 2011 program had not been included in an MRE prior to SRK's 2018 estimation, reported in Section 11 of this report. Many of the 2011 drill holes were located outside the resource model boundary, and not used directly in the M3 2018 Technical Report.

On February 24, 2016, McEwen transacted the purchase of the GBS property, then known as Afgan-Kobeh, from NV Gold. Between May and June 2016, McEwen drilled 12 RC step-out holes east of the main deposit area testing for down-dip extensions of gold mineralization. All these holes are located within the resource model boundary and were used for the 2018 MRE.

McEwen conducted gravity and Controlled Source Magneto Telluric (CSMT) geophysical surveys over the GBS property as part of broader surveys across the Gold Bar camp. Historic geophysics were also compiled and integrated into these surveys for the first time generating unified gravity, Controlled Source Audio-frequency Magneto Telluric (CSAMT) and magnetic maps. In 2019, McEwen renewed focus on the property consisting of additional geophysical work (gravity) and selected rock chip sampling plus drilling 209 infill and step-out RC holes. In addition, five HQ core holes were drilled for geotechnical work along with five PQ metallurgical holes. Work by McEwen continued in 2020 with the addition of 82 RC step-out holes north and south of the deposit plus 16 oriented core holes to better understand structural controls to mineralization. Four PQ core holes were also drilled across the deposit footprint to collect material for metallurgical test work as part of this program.

### **5.3 HISTORICAL MINERAL RESOURCE AND RESERVE ESTIMATES**

Historical resource and reserve estimates for Gold Bar North are described in detail in the 2010 Technical Report produced by Telesto (Telesto, 2010). Similarly, historical resource estimates for Gold Bar South are presented in the 2011 Technical Report by MDA (MDA, 2011). These historical mineral resource and mineral reserve estimates do not adhere to the current NI 43-101 guidelines and therefore not relevant to the updated mineral resource presented in this report. Recent and relevant NI 43-101 resource estimates as reported by Telesto, (2008, 2009, 2010) MDA (2006), SRK (2012, 2015), and M3 (2018) are presented below.

A Qualified Person has not done sufficient work to classify any of the historical estimates as a current Mineral Resource or Mineral Reserve; and McEwen is not treating any of the historical estimates as current Mineral Resources or Mineral Reserves.

#### **5.3.1 Gold Bar North Resource Estimation History 2006-2018**

##### **Summary and Key Points**

- Hand-drawn gold envelopes incorporating geology and structure used by the MDA and Telesto resource models 2006-2010
- SRK models in 2012-2018 used computer-generated grade shells based on variography and assumptions about structural and bedding control.
  - 2006 Gold Pick only Indicated Mineral Resource 280.5 koz, 0.042 opt
  - 2008 Gold Pick plus Gold Ridge Measured Mineral Resource & Indicated Mineral Resource 471.5 koz, 0.036 opt; Inferred Mineral Resource 94.7 koz, .036 opt
  - 2009 Gold Pick plus Gold Ridge Measured Mineral Resource & Indicated Mineral Resource 681.2 koz, 0.032 opt; Inferred Mineral Resource 186 koz, .021 opt
  - 2010 Gold Pick plus Gold Ridge Measured Mineral Resource & Indicated Mineral Resource 883.5 koz, 0.027 opt; Inferred Mineral Resource 19 koz, .016 opt
  - 2012 Gold Pick only Measured Mineral Resource & Indicated Mineral Resource 459.8 koz, 0.028 opt; Inferred Mineral Resource 161.8 koz, 0.029 opt
  - 2015 Gold Pick only Measured Mineral Resource & Indicated Mineral Resource 479 koz, 0.028 opt; Inferred Mineral Resource 77 koz, 0.025 opt
  - 2018 Gold Pick plus Gold Ridge plus Cabin Creek Measured Mineral Resource & Indicated Mineral Resource 721 koz, 0.027 opt; Inferred Mineral Resource 197 koz, 0.026 opt

##### **5.3.1.1 2006 43-101 report on Gold Pick and Gold Ridge North by Mine Development Associates (MDA) for White Knight (predecessor company to US Gold and McEwen)**

- Approach:
  - Review mineral resource estimates and mineralization model by earlier workers to prepare in accordance with 43-101 standards.

**GOLD BAR PROJECT**  
**S-K 1300 TECHNICAL REPORT SUMMARY**

- Data validation:
  - MDA completed a rigorous check of the data integrity used in their estimate, looking at 13% of the gold assay data. They noted that QA/QC data were less than required by modern standards, but those working on the estimate had first-hand experience and knowledge of the deposits being evaluated. Reviewed mineralized outlines in detail. Used Atlas data, no new data were available then. Atlas used commercial labs for drill samples, amounting to 111,121 gold fire assays, 24,445 gold AA assays and 27 gold cyanide assays. Cyanide recovery data (1725 samples) were generated at the mine site using “mini-CIL” methods used to predict mill recoveries.
- Geological Understanding:
  - Quoted MRDI 1995 report saying “these deposits are hosted by the Bartine and are dominated by high-angle structural controls (feeders) to ore localization, with subordinate facies control. This results in a deposit characterized by high grade, somewhat discontinuous pods and ore shoots developed along faults and lines of structural intersection not overly influenced by facies control.” Steeply dipping north 36° west-striking faults and north 80° east-striking faults are the two major ore-control orientations.
- Model:
  - Reviewed 1994 model and resource estimate, found it to be high quality, stating it would be equivalent to Indicated Resources under current standards. This model is not shown in map or section view. It is not known how much geological data were used to generate it.
- Mineral Resource Estimate:

**Table 5-1: Gold Pick Indicated Mineral Resources (after Tschabrun, 1994)**

| Mineralization Type | Cut-off Grade oz Au/t | Gold Pick Deposit |               |                 | Gold Ridge North Deposit |               |                 | Totals       |               |                 |
|---------------------|-----------------------|-------------------|---------------|-----------------|--------------------------|---------------|-----------------|--------------|---------------|-----------------|
|                     |                       | Tons 000's        | Grade oz Au/t | Ounces Au 000's | Tons 000's               | Grade oz Au/t | Ounces Au 000's | Tons 000's   | Grade oz Au/t | Ounces Au 000's |
| <b>Oxide</b>        | 0.01                  | 4,738             | 0.039         | 184.8           | 1,108                    | 0.034         | 37.7            | 5,846        | 0.038         | 222.5           |
| <b>Carbonaceous</b> | 0.01                  | 1,954             | 0.049         | 95.7            | 74                       | 0.037         | 2.7             | 2,028        | 0.049         | 98.4            |
| <b>Totals</b>       | <b>0.01</b>           | <b>6,692</b>      | <b>0.042</b>  | <b>280.5</b>    | <b>1,182</b>             | <b>0.034</b>  | <b>40.4</b>     | <b>7,874</b> | <b>0.041</b>  | <b>320.9</b>    |

Table from MDA 2006 report

5.3.1.2 2008 43-101 report on Gold Pick and Gold Ridge by Telesto Nevada Inc for US Gold Corp

- Approach:
  - Review and update historical resource estimates with new information received from US Gold. New information consisted of drill hole lithology and alteration of historical (Atlas) data.
- Data validation:
  - Telesto selected 73 drill holes at random to cross check the accuracy of historical gold assay data between the three labs that Atlas used. Correlation ratio between labs is 1.004.

**GOLD BAR PROJECT**  
**S-K 1300 TECHNICAL REPORT SUMMARY**

- Geological Understanding:
  - Telesto were also aware of the high-angle northeast and east-northeast-trending fault-control to mineralization at Gold Pick and the other deposits in the Gold Bar district.
- Model:
  - US Gold provided 2-D gold envelopes generated on cross sections, which Telesto noted followed the surface-mapped NE- and NW-trending faults. No capping of high grades was done. Variograms showed a steeply dipping structural influence.
- Resource estimate for Gold Pick plus Gold Ridge using .008 opt cut-off:
  - Measured Mineral Resource & Indicated Mineral Resource 471.5 koz, .036 opt
  - Inferred Mineral Resource 94.7 koz, .036 opt

**Table 5-2: Results of Telesto's November 2008 Estimate of Gold Pick and Gold Ridge**

| <u>Metric</u>          | <u>Rock Type</u> | <u>Cut-off Grade (g/tonne)</u> | <u>Tonnage (tonnes)</u> | <u>Au (g)</u>  | <u>Avg. Grade (g/tonne)</u> |
|------------------------|------------------|--------------------------------|-------------------------|----------------|-----------------------------|
| <b>Indicated</b>       |                  |                                |                         |                |                             |
|                        | 55               | 0.28                           | 681,000                 | 1,276,080      | 1.87                        |
|                        | 66               | 0.28                           | 11,114,000              | 13,390,424     | 1.20                        |
| <b>Total Indicated</b> |                  |                                | 11,795,000              | 14,666,504     | 1.24                        |
| <b>Inferred</b>        | 88               | 0.28                           | 1,953,000               | 2,944,754      | 1.51                        |
| <u>Imperial</u>        | <u>Rock Type</u> | <u>Cut-off Grade (oz/ton)</u>  | <u>Tonnage (tons)</u>   | <u>Au (oz)</u> | <u>Avg. Grade (oz/ton)</u>  |
| <b>Indicated</b>       |                  |                                |                         |                |                             |
|                        | 55               | 0.0082                         | 750,803                 | 41,028         | 0.055                       |
|                        | 66               | 0.0082                         | 12,253,185              | 430,519        | 0.035                       |
| <b>Total Indicated</b> |                  |                                | 13,003,988              | 471,547        | 0.036                       |
| <b>Inferred</b>        | 88               | 0.0082                         | 2,153,183               | 94,677         | 0.044                       |

Source: Telesto, 2010

5.3.1.3 2009 43-101 report on Gold Pick and Gold Ridge by Telesto Nevada Inc for US Gold Corp

- Approach:
  - Expanded on and updated 2008 report to include drilling of 19 holes completed in late 2008 at Gold Pick.
- Data validation:
  - Telesto used the same data that was reviewed for the 2008 report, with the addition of new drill holes. They spot-checked drill data and determined the data quality to be sufficient to calculate a resource.
- Geological Understanding:
  - Enhanced 2-D gold envelopes, along with 19 drill holes generated by US Gold, allowed some indicated resources at Pick to be converted to measured.

**GOLD BAR PROJECT**  
**S-K 1300 TECHNICAL REPORT SUMMARY**

- Model:
  - Increase in resource attributed to enhanced mineralized envelopes on cross sections, careful resource classification and a study of drill hole density. Variograms used to generate model.
- Mineral Resource Estimate for Gold Pick plus Gold Ridge using 0.012 opt cut-off (Table 5-3):
  - Measured Mineral Resource & Indicated Mineral Resource 681.2 koz, 0.032 opt
  - Inferred Mineral Resource 186 koz, 0.021 opt
- Resource estimate for Cabin Creek is reported in Table 5-4.

**Table 5-3: Results of Telesto's May 2009 Estimate of Gold Pick and Gold Ridge**

| Metric                      | Rock Type | Cut-off Grade (g/tonne) | Tonnage (tonnes)  | Au (g)            | Avg. Grade (g/tonne) |
|-----------------------------|-----------|-------------------------|-------------------|-------------------|----------------------|
| <b>Measured</b>             |           |                         |                   |                   |                      |
|                             | 44        | 0.411                   | 10,363,000        | 11,622,000        | 1.121                |
|                             | 55        | 0.411                   | 733,000           | 1,136,000         | 1.550                |
|                             | 77        | 0.411                   | 5,175,000         | 6,386,000         | 1.234                |
| <b>Total Measured</b>       |           |                         | <b>16,271,000</b> | <b>19,144,000</b> | <b>1.176</b>         |
| <b>Indicated</b>            |           |                         |                   |                   |                      |
|                             | 44        | 0.411                   | 2,998,000         | 1,851,000         | 0.617                |
|                             | 55        | 0.411                   | 70,400            | 64,400            | 0.915                |
|                             | 77        | 0.411                   | 149,000           | 87,900            | 0.590                |
| <b>Total Indicated</b>      |           |                         | <b>3,217,400</b>  | <b>2,003,300</b>  | <b>0.624</b>         |
| <b>Measured + Indicated</b> |           |                         | <b>19,488,400</b> | <b>21,147,300</b> | <b>1.085</b>         |
| <b>Inferred</b>             | <b>88</b> | 0.411                   | 7,879,000         | 5,782,000         | 0.734                |
| Imperial                    | Rock Type | Cut-off Grade (oz/ton)  | Tonnage (ton)     | Au (oz)           | Avg. Grade (oz/ton)  |
| <b>Measured</b>             |           |                         |                   |                   |                      |
|                             | 44        | 0.012                   | 11,423,000        | 374,000           | 0.033                |
|                             | 55        | 0.012                   | 808,000           | 36,600            | 0.045                |
|                             | 77        | 0.012                   | 5,705,000         | 206,000           | 0.036                |
| <b>Total Measured</b>       |           |                         | <b>17,936,000</b> | <b>616,600</b>    | <b>0.034</b>         |
| <b>Indicated</b>            |           |                         |                   |                   |                      |
|                             | 44        | 0.012                   | 3,305,000         | 59,700            | 0.018                |
|                             | 55        | 0.012                   | 77,600            | 2,100             | 0.027                |
|                             | 77        | 0.012                   | 164,000           | 2,800             | 0.017                |
| <b>Total Indicated</b>      |           |                         | <b>3,546,600</b>  | <b>64,600</b>     | <b>0.018</b>         |
| <b>Measured + Indicated</b> |           |                         | <b>21,482,600</b> | <b>681,200</b>    | <b>0.032</b>         |
| <b>Inferred</b>             | <b>88</b> | 0.012                   | 8,685,000         | 186,000           | 0.021                |

Source: Telesto, 2010



**Table 5-4: Results of Telesto's May 2009 Estimate of Cabin Creek**

| Metric    | Cut-off Grade (g/tonne) | Tonnage (tonnes) | Au (g)    | Avg. Grade (g/tonne) |
|-----------|-------------------------|------------------|-----------|----------------------|
| Indicated | 0.411                   | 2,879,400        | 2,386,600 | 0.829                |
| Inferred  | 0.411                   | 57,300           | 29,300    | 0.511                |
| Imperial  | Cut-off Grade (oz/t)    | Tonnage (ton)    | Au (oz)   | Avg. Grade (oz/t)    |
| Indicated | 0.012                   | 3,174,000        | 76,700    | 0.024                |
| Inferred  | 0.012                   | 63,200           | 940       | 0.015                |

Source: Telesto, 2010

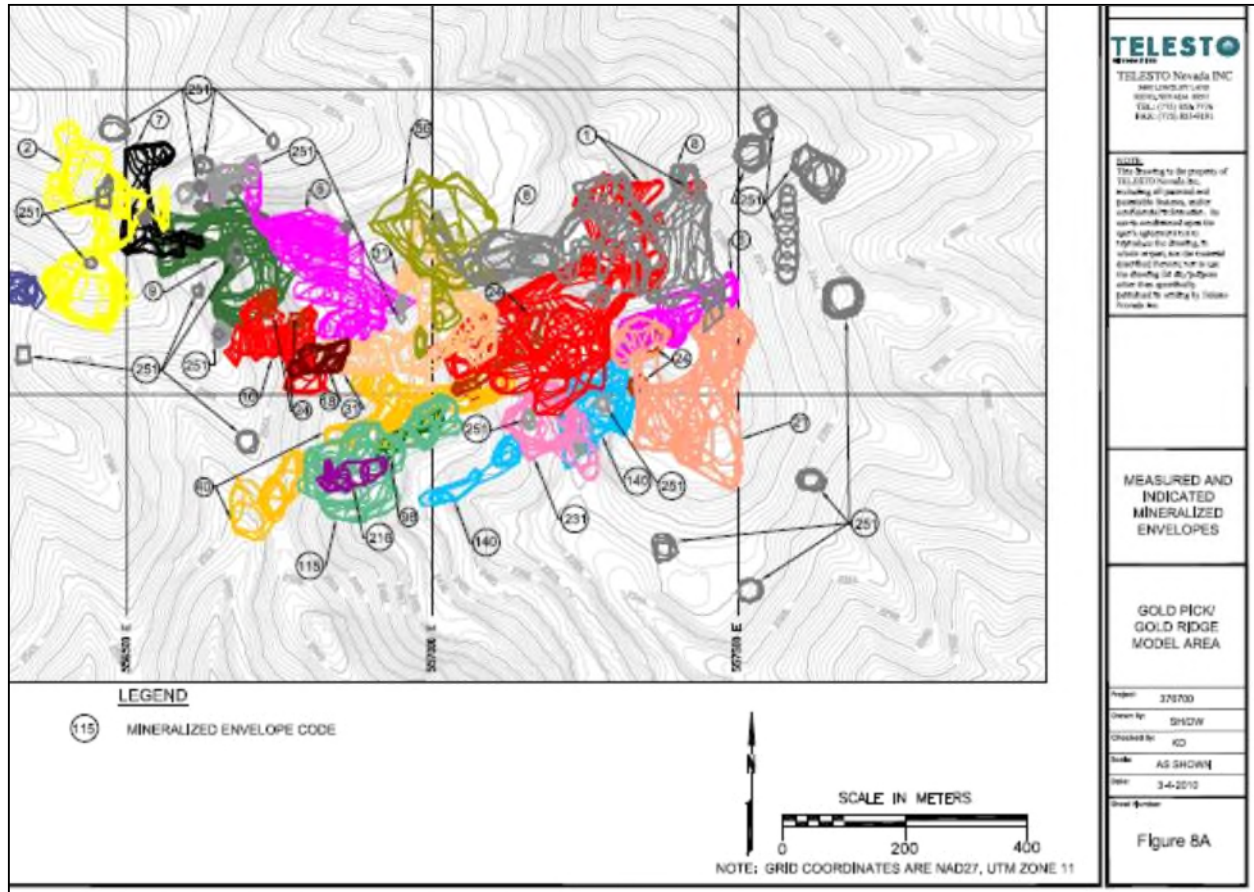
5.3.1.4 2010 43-101 Preliminary Assessment of the Gold Pick and Gold Ridge Deposits by Telesto Nevada Inc for US Gold Corp

- Approach:
  - Provide a prelim assessment of Gold Pick and Gold Ridge by reviewing historical mineral resources and reserves, updating with new drill data and gold envelopes provided by US Gold. Estimating gold content, expected recoveries, preliminary design of facilities.
- Data validation:
  - Telesto reviewed the 2009 drill data before including it in the existing database that was already verified. 107 RC holes drilled by US Gold in 2009 were added to the database.
- Geological Understanding:
  - 2-D gold envelopes were joined to create 3-D mineralized envelopes using cross sections every 100 ft. and bench plans every 20 ft. This was provided to Telesto, who plotted them on the geologic map and confirmed that the mineralization envelopes matched the mapped faults.
- Model:
  - Gold envelopes honored bedding and vertical control to grade distribution.
  - Variograms underscore the structural control to mineralization.
  - 107 new drill holes at Gold Pick in 2009 contributed to increase in resource.
  - Screenshot of this model below.
- Mineral Resource Estimate for Gold Pick plus Gold Ridge using 0.012 opt cut-off (Table 5-5):
  - Measured Mineral Resource & Indicated Mineral Resource 883.5 koz, 0.027 opt
  - Inferred Mineral Resource 19 koz, 0.016 opt

**Table 5-5: Results of Telesto's 2010 Estimate of Gold Pick plus Gold Ridge Resources**

| <b>Imperial</b>                   | <b>Cut-off Grade (opt)</b> | <b>Tonnage (ton)</b> | <b>Au (oz)</b> | <b>Avg. Grade (opt)</b> |
|-----------------------------------|----------------------------|----------------------|----------------|-------------------------|
| <b>Measured</b>                   |                            |                      |                |                         |
| High Grade                        | 0.012                      | 15,735,000           | 472,343        | 0.030                   |
| Mid Grade                         | 0.012                      | 10,153,000           | 268,691        | 0.026                   |
| Low Grade                         | 0.012                      | 5,269,000            | 109,093        | 0.021                   |
| <b>Total Measured</b>             | <b>0.012</b>               | <b>31,157,000</b>    | <b>850,127</b> | <b>0.027</b>            |
| <b>Indicated</b>                  |                            |                      |                |                         |
| High Grade                        | -                          | -                    | -              | -                       |
| Mid Grade                         | 0.012                      | 2,103,000            | 33,348         | 0.016                   |
| Low Grade                         | -                          | -                    | -              | -                       |
| <b>Total Indicated</b>            | <b>0.012</b>               | <b>2,103,000</b>     | <b>33,348</b>  | <b>0.016</b>            |
| <b>Measured + Indicated</b>       |                            |                      |                |                         |
| High Grade                        | 0.012                      | 15,735,000           | 472,343        | 0.030                   |
| Mid Grade                         | 0.012                      | 12,256,000           | 302,039        | 0.025                   |
| Low Grade                         | 0.012                      | 5,269,000            | 109,093        | 0.021                   |
| <b>Total Measured + Indicated</b> | <b>0.012</b>               | <b>33,260,000</b>    | <b>883,475</b> | <b>0.027</b>            |
| <b>Inferred</b>                   | <b>0.012</b>               | <b>1,202,000</b>     | <b>18,929</b>  | <b>0.016</b>            |

**GOLD BAR PROJECT  
S-K 1300 TECHNICAL REPORT SUMMARY**



**Figure 5-1: Plan view of gold envelopes provided to Telesto and used for resource model of Gold Pick deposit (Telesto, 2010)**

5.3.1.5 2012 43-101 Prefeasibility Study of the Gold Bar Project by SRK for McEwen Mining

- Approach:
  - Provide a comprehensive technical and economic analysis including metallurgy, mining, processing for three deposits at Gold Bar. Collected data for metallurgy (column tests), geotech core for slope stability, waste characterization and water.
  - LoM NPV of \$45.1 million, IRR 34.4% at \$1,300 gold price.
- Data validation:
  - SRK verified 6.2% of the drill hole database and found them to be suitable for resource estimation.
- Geological Understanding:
  - SRK built computer-generated grade shells in Leapfrog.
  - Both stratigraphy and structures used to create grade shells
  - Northeast-trending structural control recognized at Gold Pick

**GOLD BAR PROJECT**  
**S-K 1300 TECHNICAL REPORT SUMMARY**

- Assumed much of mineralization mimics bedding
- Favorable beds mineralized at intersection of high-angle NE-trending structures
- Model:
  - SRK estimated grades using inverse distance weighted (IDW) to the second power
  - Second grade estimation pass used nearest neighbor.
  - Minimum distance to nearest 3-m composite used to classify resource
  - Density calculated at 2.5 g/cc from 95 surface samples, 74 core samples
- Mineral Resource Estimate for Gold Pick only using 0.009 opt cut-off (Table 5-6):
  - Measured Mineral Resource & Inferred Mineral Resource 459.8 koz, 0.028 opt
  - Inferred Mineral Resource 161.8 koz, 0.029 opt
- Reserve Statement for Gold Pick using 0.008 opt cut-off:
  - Proven & Probable 370.9 koz, 0.029 opt

**Table 5-6: Mineral Resource Statement Gold Bar Deposit, Eureka County Nevada, SRK Consulting (U.S.) Inc., Effective November 28, 2011**

| Resource Estimate    | Mass (kt) | Au Grade (g/t) | Contained Au (g) | Contained Au (oz) |
|----------------------|-----------|----------------|------------------|-------------------|
| <b>Gold Pick</b>     |           |                |                  |                   |
| Measured             | 551       | 1.22           | 673,645          | 21,658            |
| Indicated            | 14,466    | 0.94           | 13,628,333       | 438,165           |
| M&I                  | 15,017    | 0.95           | 14,301,978       | 459,823           |
| Inferred             | 5,125     | 0.98           | 5,031,277        | 161,761           |
| <b>Gold Ridge</b>    |           |                |                  |                   |
| Measured             | 72        | 1.06           | 76,333           | 2,454             |
| Indicated            | 2,273     | 0.97           | 2,197,331        | 70,646            |
| M&I                  | 2,345     | 0.97           | 2,273,664        | 73,100            |
| Inferred             | 900       | 0.86           | 778,087          | 25,016            |
| <b>Cabin Creek</b>   |           |                |                  |                   |
| Measured             | 55        | 0.97           | 53,876           | 1,732             |
| Indicated            | 2,075     | 0.87           | 1,812,482        | 58,273            |
| M&I                  | 2,130     | 0.88           | 1,866,358        | 60,005            |
| Inferred             | 1,013     | 0.78           | 789,744          | 25,391            |
| <b>All Resources</b> |           |                |                  |                   |
| Measured             | 678       | 1.19           | 803,854          | 25,844            |
| Indicated            | 18,814    | 0.94           | 17,638,146       | 567,084           |
| M&I                  | 19,492    | 0.95           | 18,442,000       | 592,928           |
| Inferred             | 7,038     | 0.94           | 6,599,108        | 212,168           |

Source: SRK, 2011

5.3.1.6 2015 43-101 Feasibility Study of the Gold Bar Project by SRK

- Approach:
  - Detailed assessments of resources, reserves, metallurgy, mining, processing etc.
  - Primary difference from 2012 PFS is evaluation of run-of-mine ore rather than crushed/agglomerated ore in previous study
  - LoM NPV \$30 million, IRR 20% at \$1,150 gold price
- Data validation:
  - SRK verified 10% of the fire assays and 20% of cyanide-soluble assays of the 38 holes drilled in 2015, new since the 2012 PFS.
  - Total of 215 holes drilled at Gold Bar by McEwen
  - 38 holes drilled at Gold Pick in 2015 converted resources to reserves
- Geological Understanding:
  - Assumed much of mineralization mimics bedding
  - SRK updated grade shells in Leapfrog using 38 new drill holes since last report
  - Both stratigraphy and NE-trending structures used to create grade shells
  - Favorable beds mineralized at intersection of high-angle NE-trending structures
- Model:
  - SRK estimated grades using inverse distance weighted (IDW) to the second power
  - Three search ellipse ranges were used
  - Minimum distance to nearest 3-m composite used to classify resource
  - Tonnage factors used are shown in Table 5-7

**Table 5-7: Density calculated at 2.5 g/cc from 95 surface samples, 74 core samples**

| Rock Type             | Tonnage Factor |
|-----------------------|----------------|
| Waste Rock            | 12.81          |
| Mineralized Oxide     | 13.35          |
| Carbonaceous Material | 12.81          |
| Fill                  | 16.7           |

Source: SRK 2015

- Gold Pick mineralization shells and domains are shown in Figure 5-2 below

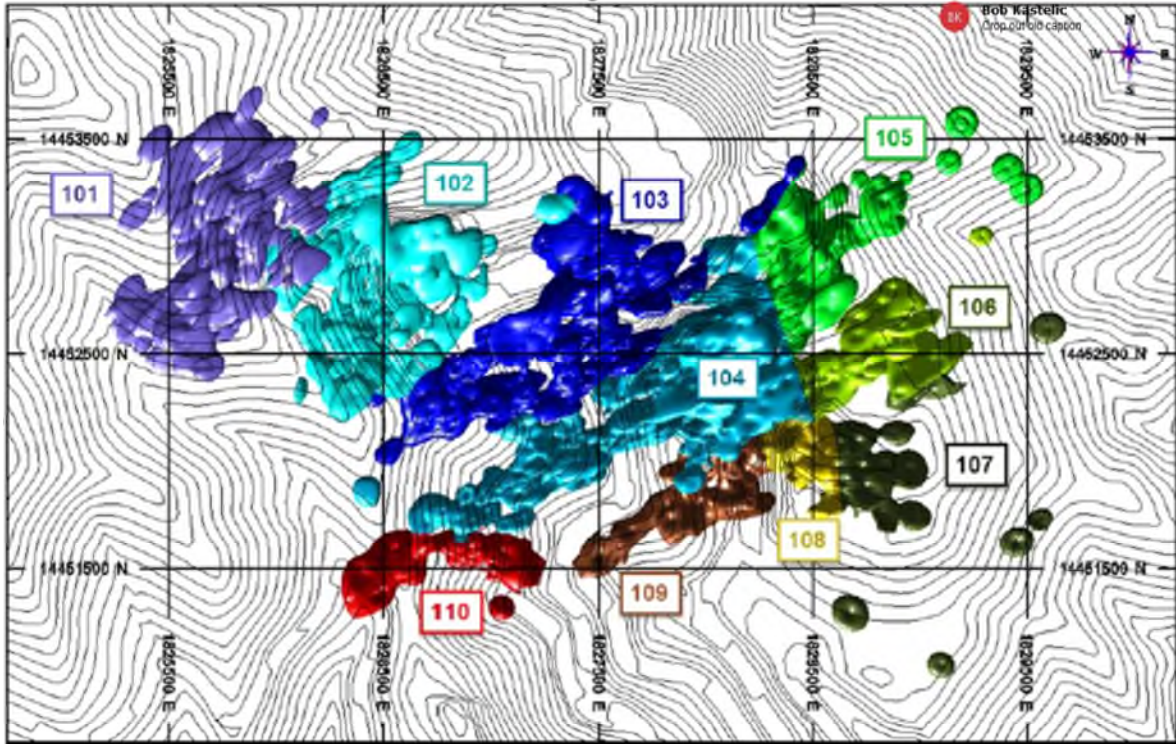
**GOLD BAR PROJECT**  
**S-K 1300 TECHNICAL REPORT SUMMARY**

- Search ellipses for interpolation domains, see Figure 5-3 below
- Resource statement for Gold Pick, Cabin Creek and Gold Ridge (Table 5-8)
  - Measured Mineral Resource & Indicated Mineral Resource 611 koz, 0.028 opt
  - Inferred Mineral Resource 111 koz, 0.024 opt
- Resource statement for Gold Pick only using 0.009 opt cut-off (Table 5-8):
  - Measured Mineral Resource & Indicated Mineral Resource 479 koz, 0.028 opt
  - Inferred Mineral Resource 77 koz, 0.025 opt

**Table 5-8: Mineral Resource Statement for the Gold Bar Gold Deposit, Eureka County, Nevada, USA, SRK Consulting, Effective July 9th, 2015**

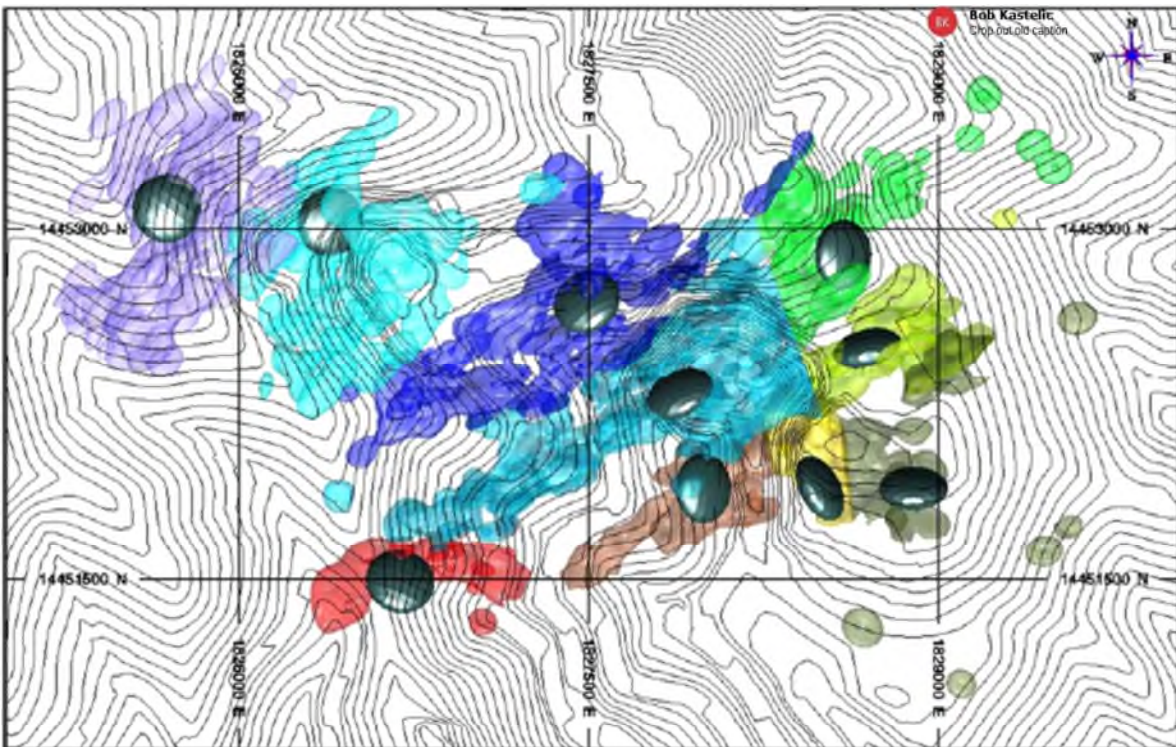
| Pit         | Classification                | Mass          | Grade        | Contained Metal |
|-------------|-------------------------------|---------------|--------------|-----------------|
|             |                               | (ktons)       | Au (opt)     | Au (koz)        |
| ALL         | Measured                      | 2,701         | 0.035        | 96              |
|             | Indicated                     | 19,411        | 0.027        | 516             |
|             | <b>Measured and Indicated</b> | <b>22,112</b> | <b>0.028</b> | <b>611</b>      |
|             |                               |               |              |                 |
|             | Inferred                      | 4,624         | 0.024        | 111             |
| Gold Pick   | Measured                      | 2,276         | 0.036        | 83              |
|             | Indicated                     | 14,792        | 0.027        | 396             |
|             | <b>Measured and Indicated</b> | <b>17,069</b> | <b>0.028</b> | <b>479</b>      |
|             |                               |               |              |                 |
|             | Inferred                      | 3,046         | 0.025        | 77              |
| Cabin Creek | Measured                      | 243           | 0.029        | 7               |
|             | Indicated                     | 2,373         | 0.025        | 59              |
|             | <b>Measured and Indicated</b> | <b>2,616</b>  | <b>0.025</b> | <b>66</b>       |
|             |                               |               |              |                 |
|             | Inferred                      | 754           | 0.019        | 14              |
| Gold Ridge  | Measured                      | 182           | 0.030        | 6               |
|             | Indicated                     | 2,246         | 0.027        | 61              |
|             | <b>Measured and Indicated</b> | <b>2,427</b>  | <b>0.028</b> | <b>67</b>       |
|             |                               |               |              |                 |
|             | Inferred                      | 824           | 0.024        | 20              |

Source: SRK 2015



Source: SRK 2015

Figure 5-2: Gold Pick Mineralization Shell (0.006 oz/t Au) and Interpolation Domains



Source: SRK 2015

Figure 5-3: Gold Pick Grade Estimation Search Ellipses and Interpolation Domains

5.3.1.7 2018 (September) Update to 2015 Gold Bar Resource (SRK)

- Approach:
  - Updated model with addition of 79 drill holes
- Resource estimate for Gold Pick, Cabin Creek and Gold Ridge at 0.008 opt cut-off (Table 5-9):
  - Measured Mineral Resource & Indicated Mineral Resource 721 koz, 0.027 opt
  - Inferred Mineral Resource 197 koz, 0.026 opt
  - Block size 20x20x20 feet

**Table 5-9: Mineral Resource Estimate for Gold Pick, Cabin Creek and Gold Ridge at 0.008 opt cut-off**

| Pit         | Classification                | Mass          | Grade        | Contained Metal |
|-------------|-------------------------------|---------------|--------------|-----------------|
|             |                               | (kt)          | Au (opt)     | Au (koz)        |
| Gold Pick   | Measured                      | 2,338         | 0.036        | 84              |
|             | Indicated                     | 15,266        | 0.027        | 405             |
|             | <b>Measured and Indicated</b> | <b>17,603</b> | <b>0.028</b> | <b>489</b>      |
|             | Inferred                      | 3,227         | 0.025        | 80              |
| Cabin Creek | Measured                      | 231           | 0.030        | 7               |
|             | Indicated                     | 2,243         | 0.027        | 57              |
|             | <b>Measured and Indicated</b> | <b>2,473</b>  | <b>0.026</b> | <b>64</b>       |
|             | Inferred                      | 695           | 0.019        | 13              |
| Gold Ridge  | Measured                      | 232           | 0.030        | 7               |
|             | Indicated                     | 2,530         | 0.027        | 69              |
|             | <b>Measured and Indicated</b> | <b>2,762</b>  | <b>0.028</b> | <b>76</b>       |
|             | Inferred                      | 854           | 0.025        | 22              |

Source: SRK 2018

This report provided a mineral resource estimate and a classification of resources reported in accordance with the CIM Definition Standards for Mineral Resources and Mineral Reserves, May 10, 2014 (CIM, 2014) shown in Table 5-9. Accordingly, the Resources have been classified as Measured, Indicated, or Inferred. The resource estimate and related geologic modeling were conducted by SRK Consulting (U.S.), Inc., Reno, Nevada.

The resource model for Gold Bar North (GBN) was constructed previously, with an effective date of July 9, 2015. The information presented herein regarding Gold Bar North modeling has not changed since the issuance of the previous 2015 Technical Report (SRK, 2015). The Mineral Resource Statement summarized above (see Table 5-9) is a combined statement for Gold Bar North.



## **GOLD BAR PROJECT**

### **S-K 1300 TECHNICAL REPORT SUMMARY**

---

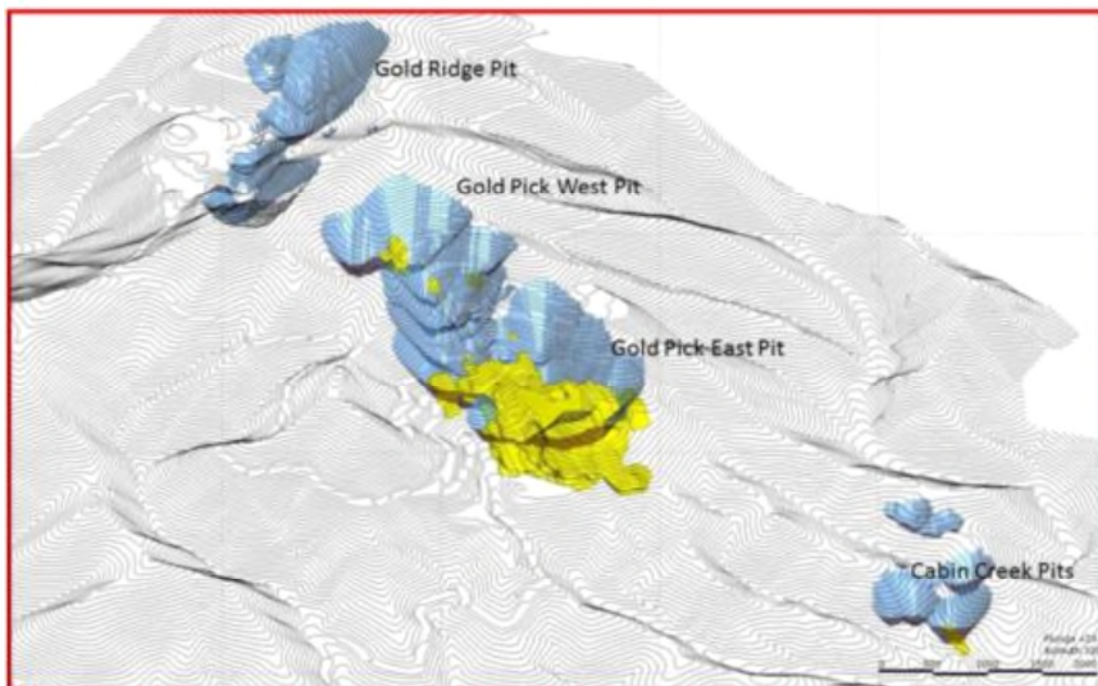
The Mineral Resource estimates were based on a 3D geological model of major structural features and geologically controlled alteration and mineralization. In GBN, a total of ten mineral domains were interpreted from mineralized drill intercepts, comprised mostly of 5 ft reverse circulation samples. The block size of the model is 20 ft x 20 ft x 20 ft. The model is in U.S. units. Gold was estimated into model blocks using the IDW interpolation method. Fill was modeled using a pre-mining topographic surface. Potentially preg-robbing carbonaceous material was modeled using cyanide soluble to fire assay ratios (CN:FA) for gold. Low CN:FA (<25%) material was excluded from the resource regardless of grade on the basis that it will impair leach performance of other mineralized material. Figure 5-4 shows the distribution of carbonaceous low recover material in the deposits. Density was derived from historic production and 2011 test work on drill core. Density was assigned based on material type.

Mineralization, particularly at Gold Pick, tracks a strong northeast-southwest fabric that is supported by structures identified during surface mapping. These northeast-southwest trending structures are at moderate to steep dip angles (45-70°NW). At Gold Pick East, the high-angle structures focus grade along azimuth 245°, dip 45-60°NW. At Gold Ridge, the orientation is azimuth 265°, dip 70°NW. The highest gold grades in the deposit are concentrated along these structures, likely at the intersection with low-angle bedding-parallel mineralization.

SRK stated that variable orientation trends exist at the Gold Bar North deposits as noted previously by Atlas (Atlas, 1996) and Mineral Resources Development Inc. (MRDI) (MRDI, 1995). To account for this, the directions of the structural controls within each interpolation domain were used to orient the search ellipses for each domain. The search range was then taken from the omni-directional variogram.

High angle faults are assumed to influence mineralization on a district scale in the Roberts Mountains and it is believed that such structures influence mineralization at Gold Bar. Within each deposit, other structural trends are also assumed to influence mineralization such as east or northeast trending structural controls at Gold Pick (SRK, 2012, Atlas, 1996).

To support interpolation, geostatistical analysis, and to better match the structural controls for grade, the mineral domains were subdivided into several separate areas referred to in this document as Interpolation Domains (Figure 5-2 and Figure 5-3). In the Gold Pick model area, ten separate interpolation domains were developed and assigned codes from 101 to 114. Cabin Creek was divided into two domains with codes 201 in the south and 202 in the north. In Gold Ridge, the grade distribution and structural controls were consistent and only one domain was necessary.



Source: SRK, 2015

**Figure 5-4: Gold Pick Low Recovery Zones (carbonaceous = yellow)**

### 5.3.2 Historic Gold Bar South Mineral Resource Estimates

#### 5.3.2.1 Pre-2000 Mineral Resource Estimates

Mineral Resource estimates were completed by three companies between 1991 and 1999. The results are summarized in Table 5-10. Additional details regarding these estimates are discussed in the MDA 2011 Technical Report.

**Table 5-10: Historic Non-43-101 Mineral Resource Estimates for GBS**

| Company      | Year      | Category (As Reported) | Gold Price | Cut-off (oz Au/ton) | Tons (x 10 <sup>6</sup> ) | Grade (oz Au/ton) | Gold (oz Au/ton) |
|--------------|-----------|------------------------|------------|---------------------|---------------------------|-------------------|------------------|
| Phelps Dodge | 1991      |                        |            |                     | 2.800                     | 0.037             | 105,000          |
| Great Basin  | 1992-1994 | "Geologic Reserves"    |            | 0.016               | 1.625                     | 0.032             | 52,000           |
| Great Basin  | 1992-1994 | "Mineable Reserves"    | \$350      |                     | 1.240                     | 0.031             | 38,400           |
| LFC Trust    | 1999      | "Daylight Resource"    |            | 0.015               | 1.265                     | 0.034             | 43,000           |

Source: MDA 2011

#### 5.3.2.2 MDA 2011

- Approach:
  - Methodical, detailed review and compilation of historic drill data (assays, logs, collar and downhole surveys, density data) from nine companies and current (2011) NV Gold drill data.

- Data validation:
  - MDA created the database using hard copy and digital data;
  - A total of 181 holes with a cumulative 63,303 drill feet from nine companies are included;
  - MDA was unable to verify collar locations on 11 of 107 holes contributing assay data to the resource;
  - Downhole deviation survey data was available for only one hole.
  
- Geologic Model:
  - Digitized geology, structure and silicification from NV Gold cross and long sections;
  - Solids and surfaces created using the sectional interpretations.
  
- Model:
  - MDA estimated grades using inverse-distance-cubed interpolation for the final resource model;
  - Block model with 20-feet x 20-feet x 20-feet blocks coded to the mineral domains by the 20-foot mineral domain polygons;
  - Resources were classified based on the number and distance of composites used in the interpolation of a block, as well as the number of holes that contributed composites;
    - Indicated - 2 composites in minimum of 2 holes within an average distance of 80 feet from block;
    - Inferred is all other estimated blocks;
  - Density calculated at 2.65 g/cc from 44 pycnometer determinations from mineralized RC samples;
  - The 2011 resources were not constrained to a potentially economic open pit configuration;
  
- Mineral Resource Estimate for GBS only using .006 opt cut-off (Table 5-11):
  - Indicated 66 koz, 0.021 opt
  - Inferred 55 koz, 0.014 opt

**Table 5-11: Gold Bar South 2011 Mineral Resource Estimate**

| Resource Class | Mass (kt) | Gold Grade (oz/t) | Contained Gold (oz) |
|----------------|-----------|-------------------|---------------------|
| Indicated      | 3,206     | 0.021             | 66,000              |
| Inferred       | 3,972     | 0.014             | 55,000              |

Source: MDA, 2011

- No Measured resources are reported for the project due to a combination of:
  - 1) the general insufficiency of QA/QC data;

- 2) the need for additional metallurgical data;
- 3) the lack of bulk-density data; and
- 4) uncertainty with regards to the precise location of some drill holes.

5.3.2.3 SRK 2018 43-101 / M3 2018 Feasibility Study

- Approach:
  - SRK 2018 model was basically an update of the 2011 MDA resource;
  - SRK built new lithology, structure, and alteration wireframes for the 2018 study.
- Data validation:
  - Comparison of drill hole composites with resource block grade estimates from all zones visually in plan and section;
  - Statistical comparisons between block and composite data using distribution analyses;
  - Statistical comparisons between the Outlier Restricted Kriging (ORK) and NN models; and
  - Swath plot analysis (drift analysis) comparing ORK with the NN model and composite grades.
- Geologic Understanding:
  - Leapfrog structural and geologic model developed based on integrating mapped geology with modeling of formation contacts and faults using the geologic database
  - Twelve domains were defined, bounded by fault blocks from the geologic model
  - Oxidized resource – 100%
- Model:
  - Blocks 20 feet x 20 feet x 10 feet thick;
  - 5-foot composites honoring mineral domain boundaries;
  - High grade capped at 0.290 oz/ton;
  - Domains used to code the block model for composite selection and grade estimation on an ore percent basis;
  - Au grade for Gold Bar South was interpolated based on a Grade Shell Informed Outlier Restricted Kriging;
  - SRK estimated grades for Gold Bar North using inverse distance weighted (IDW) estimation;
  - A search neighborhood strategy with three search ellipse ranges was used;

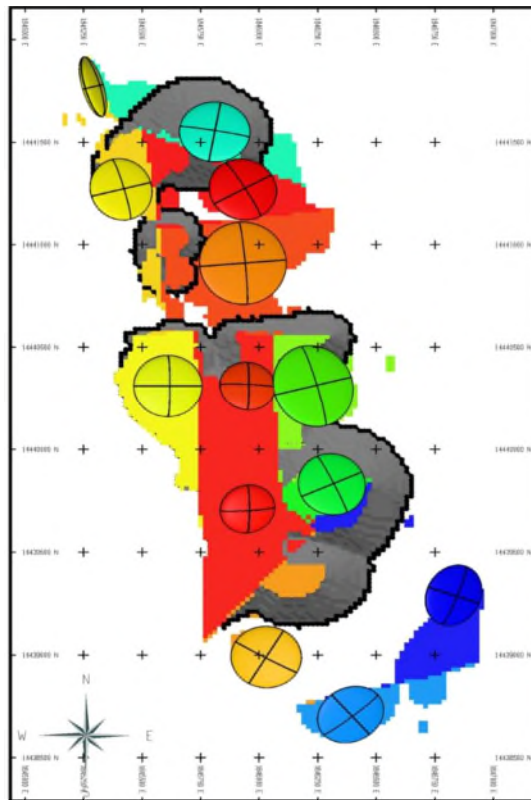
- SRK adopted tonnage factors used previously by MDA (2011) and applied those values to new lithology and alteration wireframes developed in the 2018 study (Table 5-12)

**Table 5-12: Tonnage factors supporting the 2018 SRK Resource**

| Rock Type             | Abbrev. | ft <sup>3</sup> /ton |
|-----------------------|---------|----------------------|
| Default               | Def.    | 13.0                 |
| Alluvium              | Qal     | 17.0                 |
| Tertiary Volcanics    | Tv      | 13.0                 |
| Webb Formation        | Mw      | 14.0                 |
| Devils Gate Limestone | Ddg     | 12.5                 |
| Diorite               | TK      | 13.0                 |
| Jasperoid             | Jsp     | 12.1                 |

Source: SRK 2018

- Search ellipses for interpolation domains, see Figure 5-5



Source: SRK 2018

**Figure 5-5: GBS Grade Estimation Search Ellipses**

- Resource estimate for GBS using a 0.008 opt cut-off (see Table 5-13):
  - Indicated - 100 koz, 0.029 opt
  - Inferred - 5 koz, 0.042 opt

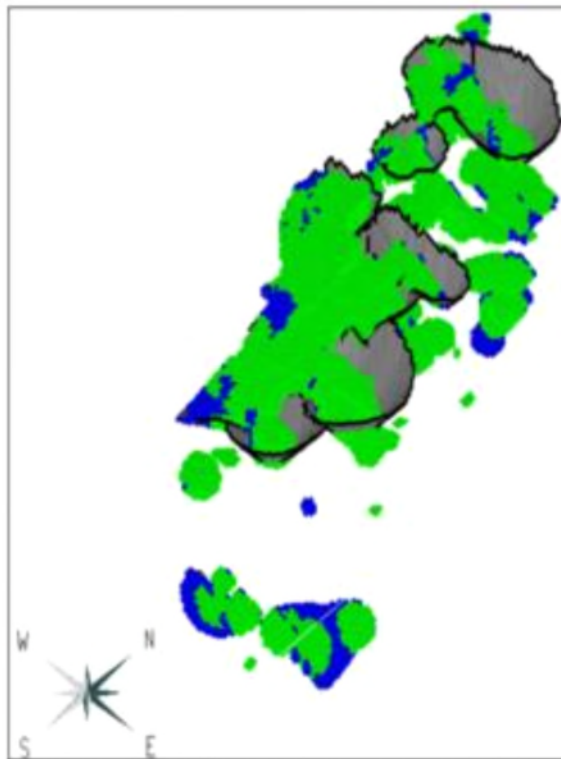
- No Measured ounces stated
- Resource drill bound, see estimated blocks in Figure 5-6; essentially no inferred mineral resource

**Table 5-13: Mineral Resource Statement for Gold Bar South**

| Pit   | Classification                | Mass         | Grade        | Contained Metal |
|-------|-------------------------------|--------------|--------------|-----------------|
|       |                               | (kt)         | Au (opt)     | Au (koz)        |
| South | Measured                      | N/A          | N/A          | N/A             |
|       | Indicated                     | 3,488        | 0.029        | 100             |
|       | <b>Measured and Indicated</b> | <b>3,488</b> | <b>0.029</b> | <b>100</b>      |
|       | Inferred                      | 123          | 0.042        | 5               |

Source: SRK 2018

- Mineral Resources are not Mineral Reserves and do not have demonstrated economic viability. There is no certainty that any part of the Mineral Resources estimated will be converted into a Mineral Reserves estimate
- Numbers in the table have been rounded to reflect the accuracy of the estimate and may not sum due to rounding
- Gold Bar South Resources stated as contained within a potentially economically minable open pit; optimization was based on assumed gold price of US\$1,350/oz, assigned recovery 82% for gold; an ore mining cost of US\$2.80/t, waste mining cost of US\$1.80/t, ore processing cost of US\$6.74/t; and pit slopes of 50 degrees
- Resources are reported using a 0.008 oz/t Au CoG.



**Figure 5-6: GBS Oblique View of Estimated Blocks Colored by Classification Code (Green=Indicated, Blue = Inferred) Source SRK 2018**

**5.4 HISTORICAL PRODUCTION GBN AND GBS**

The original Gold Bar plant was constructed during 1986, with the first gold poured in January 1987. The plant was originally designed for 1,500 tons per day throughput. An expansion in 1989 increased throughput to 3,200 tons per day. With the cessation of mining in 1994, the plant was put on standby and mothballed, ready to re-start when a new mine plan was to be completed and additional reserves found. The plant never re-started.

From inception through the 1994 cessation of operations 485,209 oz of gold were recovered from 7,514,600 tons of ore grading 0.074 oz/ton Au milled. Feed for the plant came from deposits adjacent to the McEwen resource, Gold Bar, Goldstone, and Gold Canyon. Additional material came from the Gold Pick and Gold Ridge South deposits. The Gold Ridge deposit was mined between 1991 and 1992, and the Gold Pick deposit was mined between 1992 and 1994.

McEwen started mining in July of 2018 and through December 2021 has mined 118,861 ounces Au from the Gold Pick West and Cabin Creek deposits (5,504,500 tons at 0.022 opt Au). Table 5-14 shows cumulative production statistics for the Gold Pick, Gold Ridge and Cabin Creek deposits.

There has been no production from the Gold Bar South deposit

**Table 5-14: Gold Pick/Gold Ridge Production Statistics**

| Deposit                          | Ore Mined (t) | Grade Mined (opt Au) | Ounces Gold Mined | Total Recovery (%) | Ounces Gold Recovered |
|----------------------------------|---------------|----------------------|-------------------|--------------------|-----------------------|
| Gold Pick East (Atlas)           | 502,000       | 0.079                | 39,658            | 88.8               | 35,057                |
| Gold Pick West (Atlas)           | 216,000       | 0.070                | 15,120            | 88.4               | 13,366                |
| Gold Pick Total (Atlas)          | 1,995,070     | 0.040                | 54,778            | 88.4               | 48,430                |
| Gold Ridge South (Atlas)         | 1,361,000     | 0.071                | 96,631            | 88.4               | 85,422                |
| Gold Pick W/Cabin Creek (McEwen) | 5,504,500     | 0.0215935            | 118,861           | 83.952355          | 99,787                |

Source: Atlas, 1994, McEwen, 2021

Note: This table is modified from part of Table 1 from Atlas (1994). Recovery shown is an average for all deposits, not specific to the listed deposits. Average recovery from Atlas of 88.4% was by milling methods. McEwen recovery numbers are by heap leach methods only.

## **6 GEOLOGICAL SETTING, MINERALIZATION, AND DEPOSIT**

The following description of geology and mineralization was generated by McEwen, excerpted from a recent paper on Gold Bar published by the Geological Society of Nevada (Kastelic et al., 2020). Additional information was excerpted from the M3 (2018) Technical Report, which relied heavily on interpretations from previous reports from Atlas (1996) and French et.al. (1996). Geology and mineralization of Gold Bar South (GBS) is based on recent work by McEwen, along with information abstracted from the M3 (2018) Technical Report.

### **6.1 REGIONAL GEOLOGY**

Early to middle Paleozoic rocks in north-central Nevada occur in two tectonostratigraphic packages, the western siliciclastic assemblage and the eastern carbonate-dominated assemblage. These were deposited on what was then the western margin of the North American continent. Western siliceous assemblage sediments were deposited in deep water distal from the continental margin, while the eastern assemblage carbonates were deposited on the platform, which shed debris flows and turbidites westward down the slope. The Antler Orogeny in late Devonian to Mississippian time thrust the western assemblage over the eastern assemblage along the Roberts Mountains Thrust (RMT). Subsequent major compressional events such as the Permo-Triassic Sonoma Orogeny and Cretaceous Sevier Orogeny also affected the Paleozoic rocks. Regional extension began in the Tertiary, often re-activating older compressional faults with normal motion. Extensive volcanism from the late Eocene to early Miocene deposited pyroclastic and lava flows. Younger Basin-and-Range northwest-trending block faulting during Miocene to Holocene time resulted in the current geologic and topographic configuration in the region. A property-wide geologic map is presented in Figure 6-1.

### **6.2 LOCAL AND PROPERTY GEOLOGY**

The Gold Bar District is underlain by a package of sedimentary and volcanic rocks ranging from Ordovician through Tertiary age, as well as Holocene-age alluvial deposits (Figure 6-1). Figure 6-2 shows a generalized stratigraphic column of the rocks mapped at the surface and encountered in drill holes. Mapped intrusive rocks are limited to basaltic dikes related to the Northern Nevada Rift, which trends through the eastern portion of the district. However, mafic dikes from a deep core hole drilled beneath the Gold Pick deposit yielded a mid-Jurassic age.

There are two structural blocks in the district, separated by the regionally extensive RMT. Deep-water shale and chert, mapped in the Roberts Mountains as the Vinini Formation (upper plate), were pushed eastward onto the carbonates section (lower plate) along the RMT. Late-Paleozoic clastic sedimentary rocks were deposited on both upper and lower plates. Younger (post-Permian) low angle faulting locally placed lower plate rocks on top of both the upper and lower plates. Tertiary extension resulted in the complex basin and range high-angle block faulting that defines the range today.

#### **6.2.1 Upper Plate Rocks of the Western Assemblage**

A package of siliciclastic rocks consisting of shale, siltstone, chert, and quartzite of Ordovician age also containing mafic volcanic rocks comprises the upper plate of the RMT, which overlies lower plate Eastern Assemblage carbonate rocks. Much of the upper plate has been eroded from the central part of the Gold Bar District, leaving a window of lower plate rocks exposed at the surface. The rocks of the upper plate of the RMT are highly deformed shales, cherts, quartzites, limestones, and submarine volcanic rocks that were deposited in relatively deep water on the lower slope and basin of the passive continental margin. In the Roberts Mountains, this sequence of rocks has been mapped as the Vinini Formation.



## **6.2.2 Lower Plate Rocks of the Eastern Assemblage**

Erosion has removed much of the upper plate in the Project area, exposing a large window of lower plate carbonate rocks. The lower plate autochthon consists of a thick section of limestone and dolomite deposited as debris flows and turbidites on the slope below the platform margin. See Figure 6-2 for a stratigraphic column focusing on the lower plate carbonate section in the greater Gold Bar project area. These rocks range from upper Silurian to upper Devonian in age and are, in ascending stratigraphic order; the Lone Mountain Dolomite, the McColley Canyon Formation, the Denay Formation, and the Devils Gate Limestone with a combined thickness approaching 5,000 feet. The McColley Canyon Formation disconformably overlies the Lone Mountain Dolomite.

Within the lower plate rocks, the Bartine Member of the McColley Canyon Formation and the upper Denay are particularly important as hosts for mineralization at Gold Bar North (GBN). See Figure 6-4 for a generalized geologic map focusing on the GBN geology. An interpretative geologic map of GBS is shown in Figure 6-5. Locations of these areas are illustrated on Figure 6-1 and Figure 6-3.

### **6.2.2.1 Lone Mountain Formation**

The Lone Mountain Formation is a pale gray to white, sucrosic crystalline dolomite up to 2,500 feet thick. At the time of deposition, it lay at the edge of the carbonate platform in the Gold Pick area. After deposition, it was sub-aerially exposed and eroded, at least in part, leaving an irregular surface upon which the McColley Canyon formation was deposited.

### **6.2.2.2 McColley Canyon Formation**

The McColley Canyon Formation hosts gold mineralization at Gold Pick, Gold Ridge and Cabin Creek and consists of three members, from bottom to top:

- The lower Kobeh Member is up to 100 feet thick. Mineralization can occur throughout this unit, locally extending from the Bartine Member to the Lone Mountain dolomite. It is commonly a thin-bedded dolomitic wackestone to packstone to limy dolomite to dolomite deposited as turbidites. Large brachiopods fossils are uncommon; chert nodules and bands may be abundant,
- The Bartine Member ranges from 250 to 380 feet in thickness. This member hosts the bulk of mineralization at the Gold Pick, Gold Ridge and Cabin Creek deposits. The Bartine Member is dominantly a thin- to medium-bedded fossiliferous wackestone and packstone deposited as carbonate debris flows and turbidites shed westward from the carbonate platform; beds are commonly separated by shaley partings. It commonly carries abundant large brachiopods and bulbous Favosities coral heads; and
- The upper Coils Creek Member ranges from 100 to 200 feet thick. It is a thin- to medium-bedded wackestone to packstone noted for abundant crinoid and brachiopod fossil hash, especially 2-holed crinoids, deposited as turbidites shed westward off the carbonate platform. Small chert nodules are locally present. It is not a significant ore host.

### **6.2.2.3 Denay Formation**

The Devonian Denay Formation consists of a lower slope to basin facies unit and an upper reef to slope facies unit and is broken into a lower and upper member.

- The lower Denay limestone is a 100 to 200 feet thick, generally a black evenly thin-bedded calcareous mudstone to wackestone deposited in a slope to basinal facies environment; fossils are generally not abundant. The lower Denay is generally not considered a favorable gold host.

- The upper Denay limestone is host to gold mineralization at the original Atlas Gold Bar Mine, Gold Canyon, and Goldstone pits. It is separated from the lower Denay by a massive, cliff forming grainstone to rudstones varying from 100 to 200 feet thick that is not a good ore host. However, lying conformably above the massive unit is a thin bedded, often silty, calcareous mudstone which thickens westward across the property varying from 20 to 400 feet thick. It is generally fossil-poor but does carry small brachiopods and echinoid spines locally. This is the portion of the upper Denay hosted significant mineralization mined by Atlas.

#### 6.2.2.4 Devils Gate Formation

The Devonian Devils Gate Limestone in the GBS area is a medium- to thick-bedded though locally laminated, medium- to fine-grained limestone, thinning to the west. It weathers to massive, prominent light gray outcrops often pocked with cavities. The Devils Gate formed at the carbonate-platform margin and is often moderately karsted. Stromatolites, amphipora, cladopora, favosites and stromatopora bafflestone are common, interbedded locally with thin bedded to laminated grainstone-packstones-wackestones. Karsted areas may be mineralized at GBS but are a volumetrically minor ore host.

#### 6.2.2.5 Horse Canyon Formation

At GBS the Devonian Horse Canyon Formation lies disconformably on the karsted Devils Gate limestone (Figure 6-5). Previous technical reports identified this unit as Mississippian Webb Formation (M3, 2018) and much earlier internal company reports referred to it as the Ordovician Vinini Formation (Niles, 1981; Janney, 1986); however, in 2019 McEwen confirmed a Devonian age from fossilized Radiolaria. The Horse Canyon Formation strikes northerly, dipping easterly from 30° to as much as 80° locally and can be subdivided into three units based largely on core logging:

- An upper siltstone, thin-bedded, gray, in unconformable contact with the Tertiary volcanic section;
- A middle silicious mudstone interbedded with centimeter-scale dark gray or brown chert or argillite beds that form a distinctive stripped pattern in outcrop and core; also carries lesser amounts of interbedded sandstone and pebble conglomerate. As observed in core, the basal portion of this unit grades into contorted soft sediment deformation that in turn grades into a debris flow breccia. This unit may be mineralized; and
- A clay matrix breccia supporting silicified clasts occurs at and above the basal contact of this unit with the Devils Gate Limestone which hosts the bulk of the mineralization at GBS. The genesis of this breccia zone is poorly understood. It is currently interpreted as a debris flow with a localized solution collapse breccia component above the karsted Devils Gate limestone. The high porosity and permeability of the breccia made it a preferred pathway for hydrothermal fluids and host for gold mineralization. This unit, including the matrix, may be strongly silicified locally, resulting in the prominent, bold outcrops in the central to northern portion of GBS.

### 6.2.3 Tertiary Volcanic Rocks

At GBS the Paleozoic host rocks are overlain unconformably by barren Tertiary volcanic rocks, which post-date the gold mineralization event, and therefore serve as an upper limit to the extent of economic gold mineralization. The volcanic and volcanoclastic rocks crop out on the east side of the project area. Basaltic dikes intersected in drilling are variably argillized and do not host gold mineralization. These dikes occur north of the pit shown in Figure 6-5, do not crop out and are volumetrically minor. The Tertiary section from base to top is comprised of an intercalated series of tuffs, lacustrine tuffaceous arenites to conglomerates or breccias, which can carry silicified Horse Canyon Formation cobbles, and high in the section local often sandy, limestone beds are present. These units strike northerly and dip gently eastward from 10°-25°. They are capped by several relatively thin aphanitic to amygdaloidal basalt flows which cap the ridgeline. Both the tuffaceous units and the basalts alter readily to smectite clay. The dikes and volcanic rocks

are interpreted as part of the late Eocene to Oligocene volcanism in the southern Roberts Mountains, and are the southern extension of the Northern Nevada Rift.

### **6.3 STRUCTURAL GEOLOGY**

#### **6.3.1 Faults**

The Roberts Mountains Thrust may be the oldest recognized structural feature at Gold Bar, where the upper plate siliciclastic package has been thrust over lower plate carbonate rocks. Upper plate rocks have been largely removed by erosion from the area of the deposits at Gold Bar. Upper plate rocks are exposed west of the Wall Fault, where they have been preserved from erosion in a block down dropped to the west. They are also present in the Roberts Mountains, north and east of GBN. Within the lower plate, compressional structures manifest locally as east-verging folds and low-angle fractures that dip to the west. Youngest faults trend northwest, including the Wall, Roberts Creek, Cabin Creek and Gold Ridge faults and are shown in Figure 6-1. Most-recent movement on the northwest trending faults is generally down to the west, with 300 to more than 1,000 feet of displacement. Northeast-trending faults, which do not appear to have much displacement, are important controls to mineralization in all the deposits in the Gold Bar District, including the original Gold Bar deposit (Kastelic et al. 2020). New mapping of pit exposures has found that low-angle west-dipping faults are also important controls to mineralization. Low-angle west-dipping mineralization is apparent in many of the deposits at Gold Bar and is probably influenced by similar structures.

#### **6.3.2 Folds**

A project-scale anticline plunges east-southeast about 30°. Form lines, drawn by connecting bedding strike data, show the anticlinal structure on the map in Figure 6-3. Bedding along the north limb of the anticline generally dips northeasterly from 25° to 35°, and southeasterly to south on the southern limb. Bedding along the axial trace dips 25° to 35° to the east, although local variations in dip are found. Figure 6-3 also illustrates that older rocks are exposed in the core of the anticline and younger strata on the limbs. Bedding is notably gentle in the western portion of the district near the Wall Fault and steepens eastward toward the Roberts Creek Fault. Most of the gold deposits are aligned with the axial trend of the anticline. The anticline is cut by faults and truncated on the west by the high-displacement Wall Fault, where the lower plate has been dropped down to the west approximately 1,000 feet.

Smaller-scale folds are seen in some of the pit and road cut exposures. Most of these are east-verging and are more prevalent in the western part of the district. The age of the folding is uncertain, as there have been multiple compressional events in the region (Long et al. 2014).

Younger extensional structures dissect the anticline, and some may be reactivated faults. Extensional structures trend northeast, northwest and, to a lesser degree, north. Extensional faults appear to control mineralization at GBN, especially where they intersect the favorable Bartine Member of the McColley Canyon Formation (Bartine) or, at GBS, the Horse Canyon Formation.

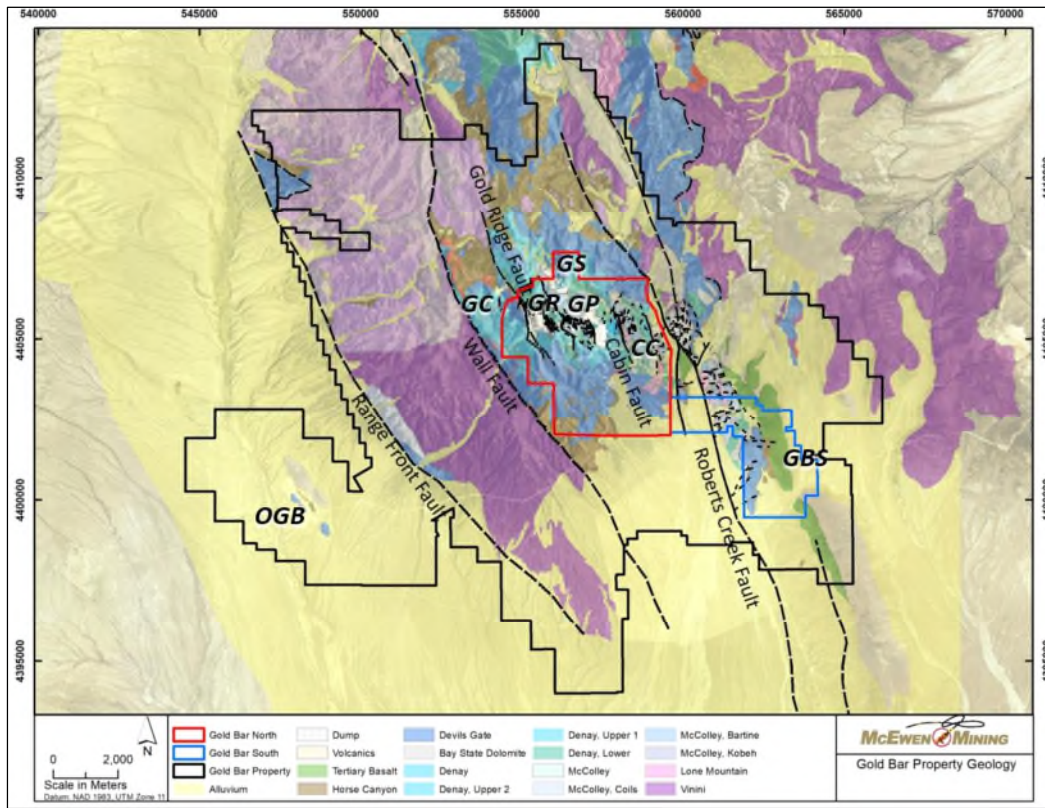
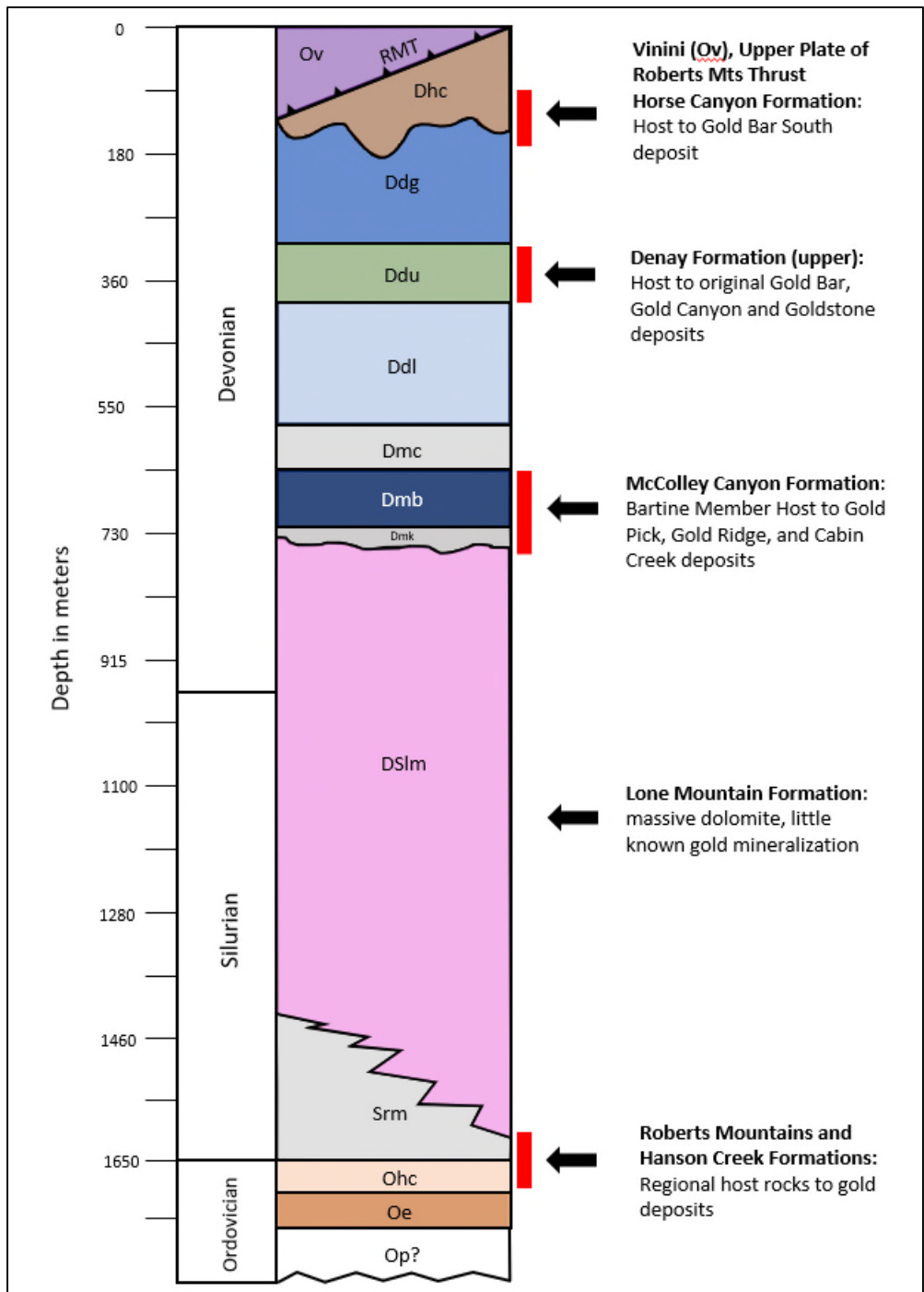


Figure 6-1: Gold Bar Property-Wide Geologic Map. Original Gold Bar Mine (OGB); Gold Canyon (GC); Gold Pick (GP); Goldstone (GS); Cabin Creek (CC); Gold Bar South (GBS)



**Figure 6-2: Gold Bar Property Stratigraphic Column (Kastelic et al., 2020)**

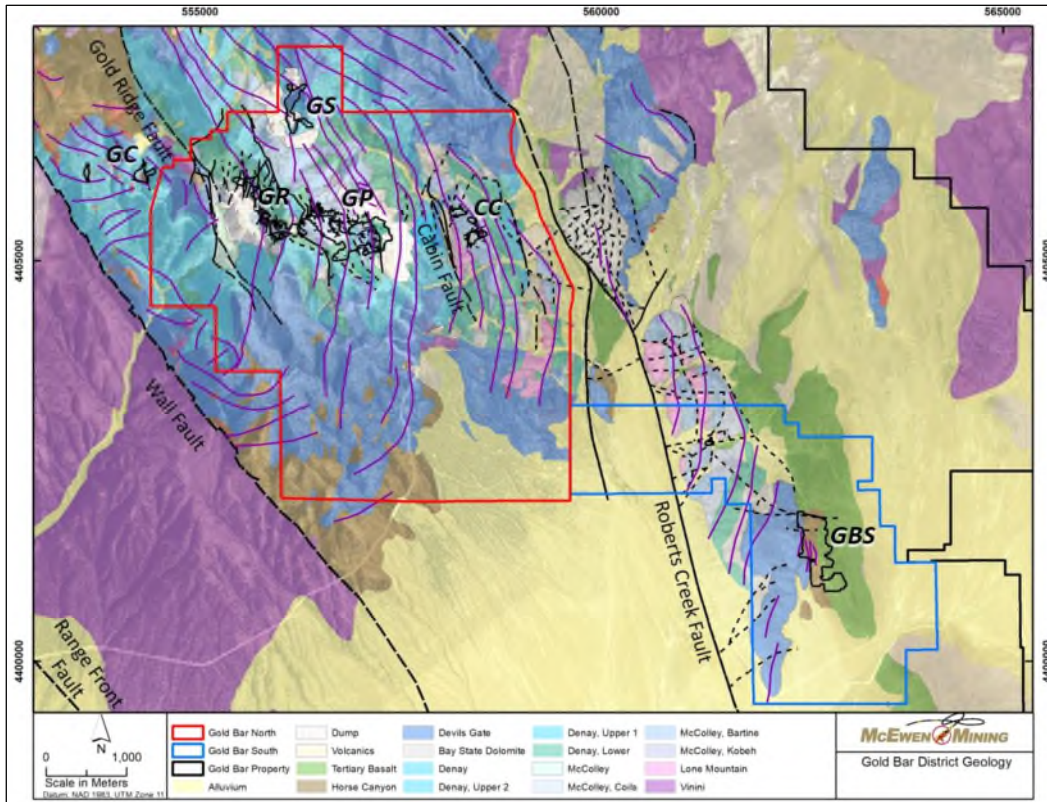


Figure 6-3: Gold Bar District Geologic Map with Form Lines. Original Gold Bar Mine (OGB); Gold Canyon (GC); Gold Pick (GP); Goldstone (GS); Cabin Creek (CC); Gold Bar South (GBS)

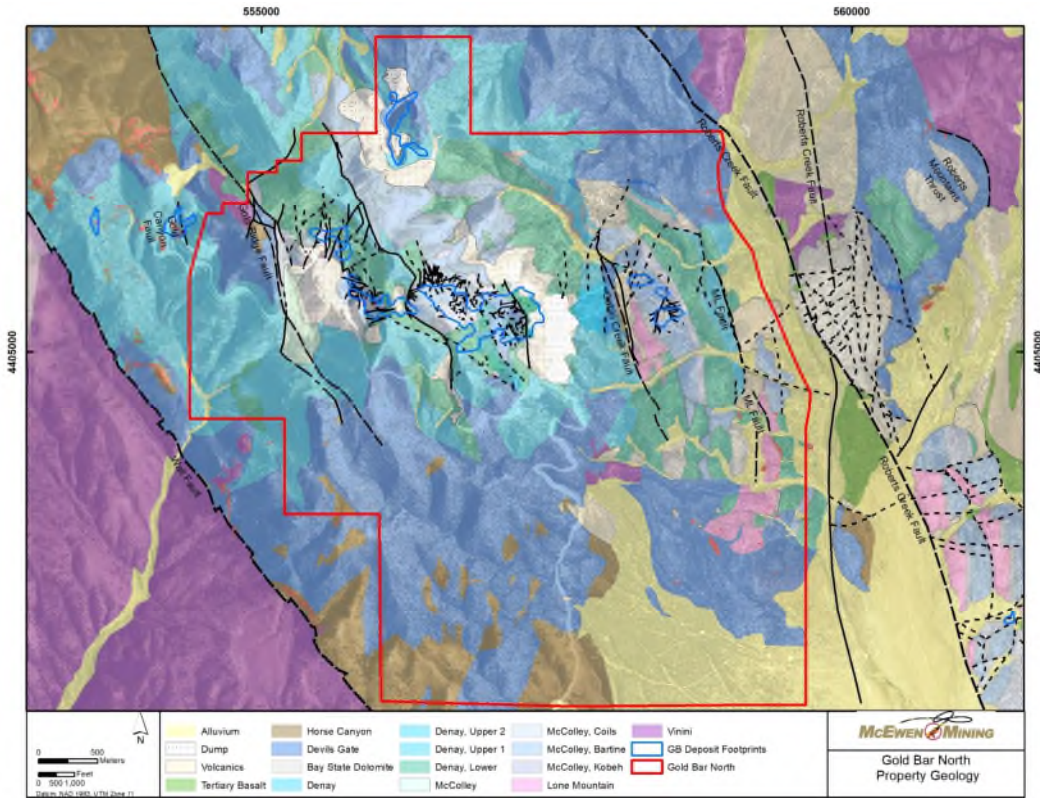
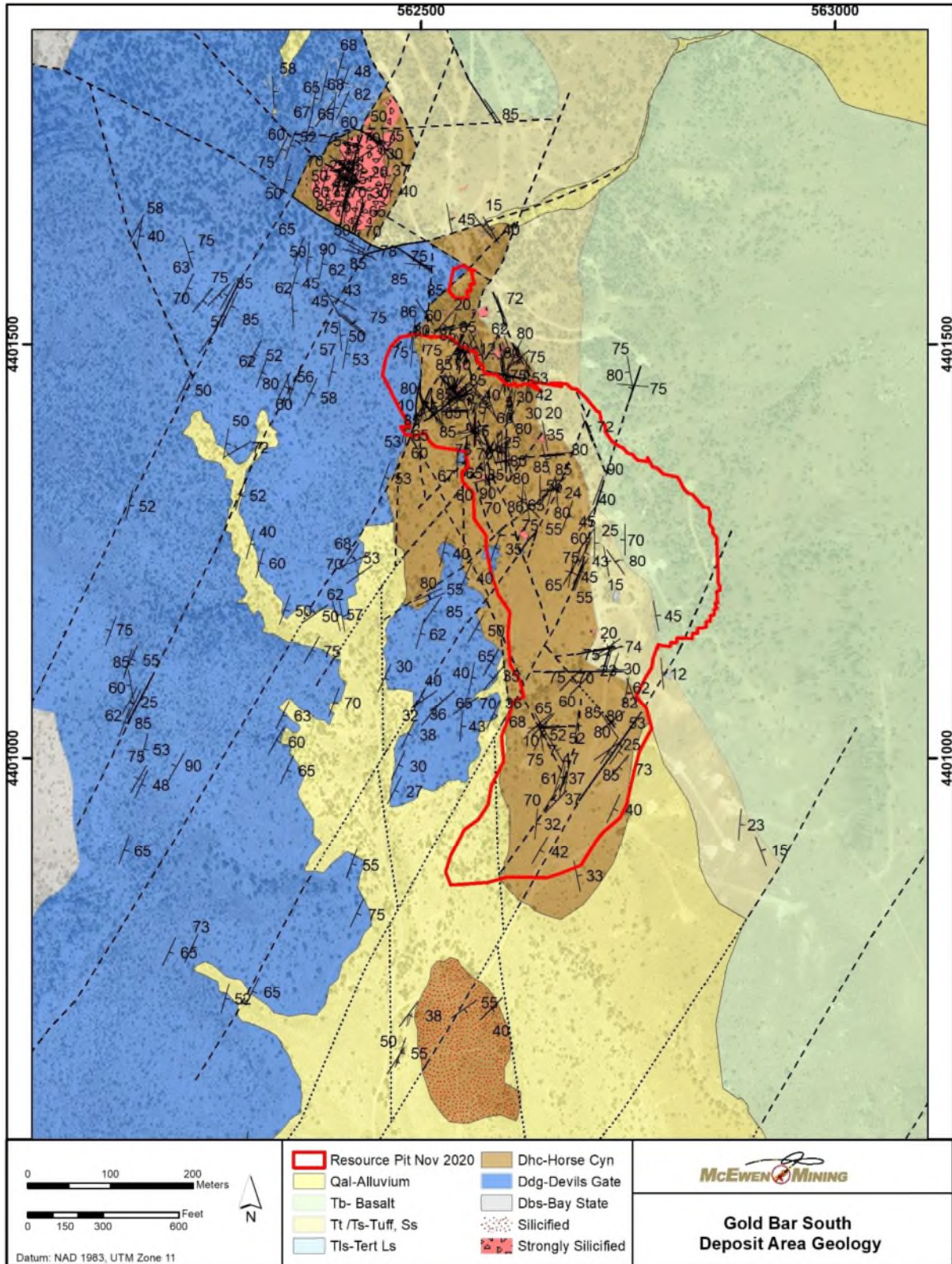


Figure 6-4: Gold Bar South Geologic Map

**GOLD BAR PROJECT  
S-K 1300 TECHNICAL REPORT SUMMARY**



**Figure 6-5: Gold Bar South Deposit Geologic Map, Perimeter of Planned \$1,725/oz LG Mineral Resource Pit Shown in Red**



## **6.4 SIGNIFICANT MINERALIZED ZONES**

### **6.4.1 Gold Bar North**

#### 6.4.1.1 Host Rock Controls on Mineralization

The Gold Bar district deposits exhibit similar lithology, structure, alteration, geochemistry, and mineralogy to other Carlin-type deposits in Nevada. Host rocks are the Devonian eastern-facies carbonate assemblage, including the McColley Canyon, Denay, Devils Gate, and Horse Canyon Formations. This package of rocks strikes generally north-south, and dips eastward between 20° and 60°, although local variations occur. In addition to tilting eastward, the rocks have been gently folded into a broad east-plunging anticline, whose axis trends west-northwest along the general trend of the gold deposits. Erosion has exposed older rocks of the McColley and Denay Formations in the core of the anticline, while younger rocks including Devils Gate and Horse Canyon are found on the limbs of the fold. The northern limb generally strikes northwest, and the southern limb strikes northeast. The Upper Denay and the Bartine member of the McColley Canyon Formation contain most of the gold deposits in the Gold Bar North area. While the gold deposits are stratabound in the sense they are contained within the two stratigraphic units, structural preparation of the host rocks, including faulting and fracturing, was essential in providing fluid pathways and open space to allow access for mineralizing fluids.

#### 6.4.1.2 Alteration Controls on Mineralization

Most of the gold mineralization in the district is oxidized and associated with decarbonatized and argillized carbonate debris-flows and turbidites. The Bartine Member contains the largest gold endowment in the district, hosting the Gold Pick, Cabin Creek and Gold Ridge deposits. The Bartine Member is a series of argillaceous wackestone debris and turbidite flows carrying abundant brachiopod shells in a lime-mud matrix. It has a high content of insoluble residues, composed of quartz silt, illite clay and iron oxide grains (Murphy and Gronberg, 1970). The clays in the mineralized zones are almost all illite, although other species are present such as ammonium illite, kaolinite and dickite (M. Mateer, Geospectral Solutions, written communication, 2019). Deposits with decarbonatization as the dominant alteration type are hosted in the Bartine in the core of the anticline. Coarse-crystalline calcite, forming irregular pods up to several meters in size, is commonly present adjacent or near decarbonatized ore zones along faults and fracture zones. Coarse-crystalline calcite is found in all the deposits in the Gold Bar District, including the original Gold Bar mine as reported by Broili et al. (1988). Calcite pods probably formed when carbonate was removed from the host limestone during decarbonatization and re-deposited where physical and chemical conditions permitted.

Silicification is locally common in areas of the gold resources. There are several generations of silicification in the district, only some of which are associated with gold (Yigit, 2001 and 2006). Mineralization in the upper stratigraphy, particularly the Horse Canyon Formation, is associated with silicification, often so intense that it is texture destructive. Strong pervasive silicification commonly occurs in and near faults and can be an aid to mapping them. Bedding-controlled silicification of varying intensity also occurs and is gold-bearing in some of the deposits.

In addition to oxidized mineralization, unoxidized podiform carbonaceous zones are found in many of the deposits. Unoxidized zones often contain orpiment, realgar, and fine-grained pyrite, are generally carbonaceous and can carry significant gold mineralization. Alteration in these zones consists of decarbonatization, argillization and brecciation, similar to the oxidized areas. Unoxidized mineralization occurs as pods and irregular zones within oxidized envelopes and are interpreted as hypogene remnants. The redox boundary is highly irregular in the Gold Bar District, and ranges from 30 meters to more than 300 meters below the surface. The depth of oxidation is influenced by bedding and faulting, which appears to have permitted oxidation to penetrate deeper in some areas.

#### 6.4.1.3 Structural Controls on Mineralization

Most of the deposits in the district are found at the intersection of northeast- and northwest-striking faults (Broili et al. 1988 and Yigit et al. 2003). Northwest-trending faults are commonly mappable, as they commonly have been re-activated after mineralization and have significantly displaced stratigraphy. Many northeast-trending structures appear to be fracture zones rather than true through-going faults with measurable displacement. Strong alteration and gold deposition occur where northeast-trending faults intersect favorable beds such as the Bartine and Upper Denay. This pattern has also been reported in the Carlin Trend (Rhys et al., 2015). Recent pit wall mapping in 2019 and 2020 in the Gold Pick pit revealed ore is controlled by and aligned with steep faults. Where northwest-trending faults and northeast-trending faults intersect, the Bartine has been intensely fractured and mineralized.

Northeast-trending faults, which do not appear to have much offset, are important controls to mineralization in all the deposits in the Gold Bar District, including the original Gold Bar deposit (Broili et al., 1988 and Yigit et al., 2003). New mapping of pit exposures has found that low-angle west-dipping faults are also important controls to mineralization. Low-angle west-dipping mineralization is apparent in many of the deposits at Gold Bar and is probably influenced by similarly-trending structures.

#### 6.4.1.4 Mineralogy

Most of the deposits have been oxidized to varying degrees, where hypogene minerals have been altered to supergene oxides and sulfates. Supergene minerals include goethite, limonite, hematite, alunite, kaolinite, stibiconite, scorodite, and jarosite. Small amounts of melanterite precipitate where ground water has evaporated from mined faces of unoxidized rock in open pits. Pyrite may be disseminated in unoxidized host rocks and is generally very fine-grained. Most orpiment, realgar, stibnite, and barite are found filling open spaces along fractures and in breccias.

These deposits exhibit a characteristic suite of Carlin-type trace elements, including arsenic, antimony, mercury, thallium, and barium  $\pm$  tungsten  $\pm$  selenium, whose abundances are elevated. Gold-to-silver ratio is about 10:1 in the GBN deposits.

### 6.4.2 Gold Bar South

#### 6.4.2.1 Host Rock Controls on Mineralization

At GBS gold mineralization is associated principally with brecciated, oxidized, variably silicified, and clay-altered siliceous mudstones, siltstones, and sandstones of the Devonian Horse Canyon Formation, with the karsted upper-most Devonian Devils Gate limestone being a locally receptive, though volumetrically minor, host.

From core logging, the basal breccia is currently interpreted as a debris flow with a solution collapse breccia component proximal and locally within the uppermost Devils Gate limestone. High porosity and permeability made the breccia a preferred pathway for hydrothermal fluids and host for gold mineralization above the massive Devils Gate limestone.

Altered and mineralized Horse Canyon Formation crops out at the surface on the west side of the resource area where it is partially eroded. It thickens down-dip to the east forming a distinct, variably continuous, north-northwest trend over a drilled strike length exceeding 4,000 feet. Areas of gold mineralization are exposed in trenches and drill pads immediately west of the central ridge crest.

#### 6.4.2.2 Alteration Controls on Mineralization

At GBS gold mineralization is associated principally with brecciated, oxidized, variably silicified, and clay-altered mudstones, siltstones, and sandstones of the Horse Canyon Formation, with the karsted upper-most Devils Gate limestone being a local and volumetrically minor host. Trench sampling as well as drilling returned good gold grades

from the clay-matrix supported basal breccia of the Horse Canyon Formation in the resource area. As was recognized at GBN (Kastelic, et. al., 2020), silicification, even strong pervasive silicification, was apparently a multi-phase event and may not necessarily correlate with gold mineralization. Strong but barren silicification has been cut in drilling immediately down dip from visually similar silicification that is mineralized.

Generally, mineralization at GBS is spatially related to varying intensities of silicification and argillic alteration. Pervasively hematite-stained, gritty clay supporting silicified clasts in the basal Horse Canyon Formation breccia is often mineralized, as are limonite-goethite encrusted fractures in weak to moderately argillized shear zones that may also exhibit weak to moderate silicification.

Argillic alteration of varying intensity is common throughout the greater GBS area in the Horse Canyon formation. Commonly it occurs as fracture encrustations of illite and Al-illite sometimes with alunite (Mateer, 2018) but varies to weak to moderate pervasive argillization as silicification intensity decreases. As noted above, clay occurs too as a gritty clay matrix supporting silicified clasts in the lower breccia unit, which can reach 200 feet in thickness and is the primary ore horizon. Smectites have not been identified in the Horse Canyon Formation and, if present, appear to be volumetrically insignificant.

Both debris flow and karst-style dissolution and collapse clay-matrix-supported breccias in the lower Horse Canyon Formation are spatially coincident with mineralization and occur not only in the same stratigraphic position as strongly silicified breccias but can occur immediately proximal to them. This relationship is observable in several trenches in the central resource area where strong pervasive silicification occurs as pod-form masses cropping out in the basal breccia immediately adjacent to clay-matrix-supported breccias. Moderately- to strongly-silicified debris-flow or solution collapse breccias are over 100-feet thick in the large prominent outcrop on the northwest end of the resource area. Silicification is stronger and extends over greater lateral and vertical distances in the north end of the resource area, decreasing in volume and intensity southward. This may be due to a silica-rich hydrothermal fluid source originating from the north.

#### 6.4.2.3 Structural Controls on Mineralization

In the core of the resource area gold mineralization is focused in a basal clay-matrix-supported breccia of the Horse Canyon Formation, especially near intersections of northeast and north to northwest-trending normal faults. Most of these faults are down to the east. Trench sampling in 2020 demonstrated a strong correlation between plus 1 ppm gold and high-angle north- to northwest-striking fault zones with low-level gold associated with cross-cutting northeast-trending faults. The northeast-trending faults also truncate or offset north- to northwest-trending faults. Overall, there is a pronounced northwest gold mineralization trend with mineralization internal to this trend following or partitioned by northeast faults. East-west trending structures are poorly defined, often appearing as discontinuous minor faults or fracture zones, but locally appear to partition grade as well. There appears to be localized “ponding” of mineralization in embayments or low spots on the Devils Gate – Horse Canyon Formation contact. These are interpreted as potential karst dissolution zones or, perhaps, in some cases, as fault zones with enhanced permeability.

#### 6.4.2.4 Mineralogy

Crystalline barite veins and jarosite fracture encrustations become increasingly common in the northern portion of GBS, especially in the large, prominent silicified outcrop on the northern end of the resource area possibly representing a manifestation of a more acidic hydrothermal fluid (Mateer, 2018). Along the central ridge in the core of the resource area illite, Al-illite, kaolinite, and alunite were identified by spectrometer in hand samples following up on an AVIRIS mineral classification map interpretation (Mateer, 2018).

Geochemically, the deposit exhibits a characteristic suite of Carlin-style trace elements including silver, arsenic, antimony, mercury, and barium  $\pm$  tungsten  $\pm$  selenium, whose abundances are variably elevated. Unlike GBN, it is common to have ore-grade samples with gold-to-silver ratios of 1:1. The entire drilled extent of GBS mineralization is

completely oxidized, to a depth locally of over 800 feet. However, some disseminated, fine-grained pyrite has been noted in the post-mineral volcanic package.

### 6.4.3 Extents and Continuity

Within the Gold Bar Project area, four discrete gold deposits have been modeled. The approximate depths and dimensions of each are summarized in Table 6-1. Each deposit shows internal continuity, with consistent anisotropy of mineralization. Approximate dimensions of each deposit are based on the grade shells constructed at a 0.2 Au g/t cut-off grade (CoG used to limit grade interpolation in the 3-D block model.)

**Table 6-1: Approximate Depths and Extents of Gold Deposits in the Project Area**

| Deposit        | Depth Range | Average Depth | Strike Length | Width | Thickness |
|----------------|-------------|---------------|---------------|-------|-----------|
|                | ft          | ft            | ft            | ft    | ft        |
| Gold Pick      | 0-500       | 165           | 4,000         | 1,650 | 150       |
| Gold Ridge     | 0-325       | 115           | 1,000         | 650   | 115       |
| Cabin Creek    | 0-325       | 100           | 1,000         | 1,300 | 115       |
| Gold Bar South | 0-700       | 350           | 3,100         | 550   | 60        |

Source: SRK 2015, updated 2018

### 6.5 DEPOSIT TYPES

Mineralization in the Gold Bar District has most of the characteristics of Carlin-type gold deposits described in Muntean and Cline (2018), including: carbonate host rocks, tectonic setting, structural and stratigraphic ore controls, hydrothermal alteration consisting of dissolution and silicification of carbonate and argillization of silicates, auriferous arsenian pyrite, a geochemical signature containing Au-As-Hg-Sb-Tl, low Ag (Ag/Au<1), and lack of clear relationship with intrusions. Most Carlin-type deposits are located along long-lived, deep crustal structures inherited from Late Proterozoic rifting and formation of a passive continental margin. They are hosted in a Paleozoic carbonate sequence (lower plate) that is either structurally overlain by a siliciclastic sequence (the Roberts Mountains Allochthon or upper plate), or stratigraphically overlain by a siliciclastic sequence deposited on the carbonate sequence (Overlap Assemblage). Gold mineralization in the Gold Bar district is localized at the intersections of a complex array of structures with permeable and reactive strata. Carbonate dissolution, argillization of silicates, sulfidation of ferroan minerals and silicification of limestone characterize the alteration assemblage related to the main stage of mineralization. Gold is found as sub-micron inclusions or solid solution in arsenian pyrite. Oxidation has liberated gold from the original pyrite, making it amenable to cyanide leaching. Common trace elements include arsenic, antimony, thallium, and mercury. Figure 6-6 shows the location of Gold Bar relative to the Battle Mountain-Eureka and Carlin Trends of gold deposits.

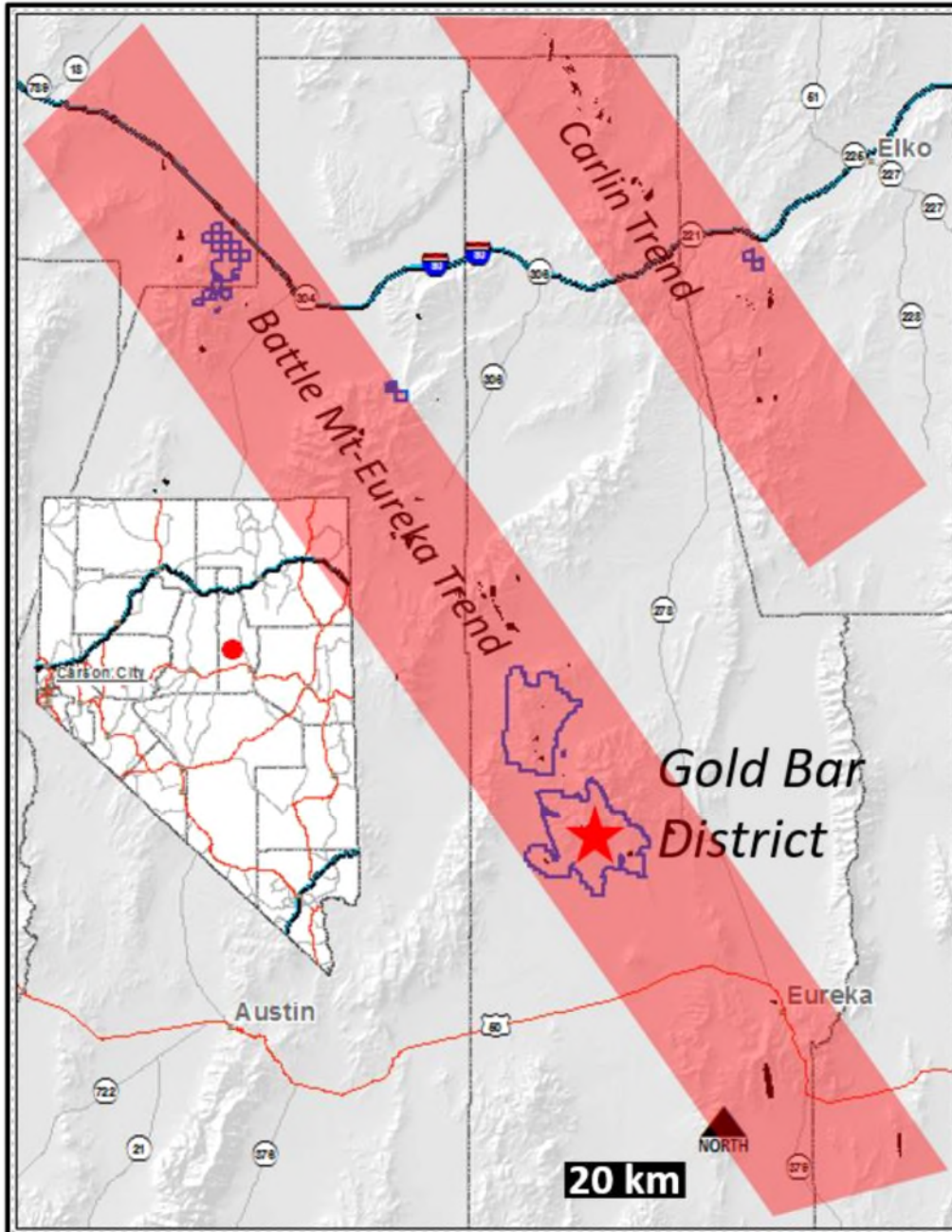


Figure 6-6: Location of Gold Bar on the Battle Mt-Eureka Trend which includes the Cortez gold deposits. Gold deposit footprints in black; McEwen properties in blue outline (Kastelic et al., 2020).

## 6.6 GOLD BAR NORTH

Gold Bar North is located on the Cortez Trend, one of four significant trends in Nevada containing Carlin-type gold deposits. This trend is marked by large-displacement faulting including the Cortez fault, which extends from Cortez to Gold Bar where it is known as the Wall fault. Host rocks at GBN are the Devonian McColley Canyon and Denay Formations, the same age and lithology as the host rocks at Cortez and other Carlin-type deposits in Nevada. Gold mineralization at GBN is controlled by a complex structural network of northeast- and northwest-trending faults intersecting favorable host rocks. The dominant alteration types are decarbonatization, argillization and silicification,

characteristics shared by most other Carlin-type deposits. Trace elements associated with gold mineralization are the same as most Carlin-type deposits, and Ag/Au ratios are less than one. Other than mafic dikes probably associated with the Northern Nevada Rift, intrusive rocks are notably absent at GBN.

## **6.7 GOLD BAR SOUTH**

Gold Bar South is also on the Cortez trend, and associated with large-scale faults such as the Roberts Creek fault. The host rocks are part of the Overlap Assemblage Horse Canyon Formation, deposited disconformably on the Devils Gate Formation which is the top of the lower plate carbonate sequence. The Devils Gate was exposed sub-areally, and weathering resulted in an irregular karsted surface upon which the Horse Canyon was deposited. This stratigraphic location is host to many Carlin-type gold deposits in Nevada. The host rocks are siliceous siltstone, sandstone, and mudstone. Gold mineralization at GBS is controlled by a complex set of northeast- and northwest-trending structures. Silicification is the dominant alteration type, while argillization is found in the matrix of breccias along the base of the Horse Canyon and the top of the Devils Gate. Elevated trace elements are the same as most Carlin-type deposits, with the exception that the Ag/Au ratio at GBS is approximately one.

## **6.8 DESCRIPTIONS OF MINERALIZATION**

Most mineralization at GBN is associated with significant amounts of clay alteration (argillization), with a lesser amount of ore associated with silicification. Clay appears to have formed by the incomplete dissolution of calcite from the original argillaceous limestone, leaving a residue enriched in silt and clay. In general, the stronger gold mineralization is associated with stronger argillization. At GBS, silicification is the more dominant alteration type associated with gold, although clay alteration is also present. These characteristics are common to both oxidized and un-oxidized ore. Following are descriptions of the ore types at the Gold Bar project.

- **Oxide ore:** Natural weathering and supergene oxidation of hypogene refractory ore resulted in the formation of oxide ore (with low sulfide mineral and carbon contents) from which gold is recovered by cyanide heap leaching. Original sulfide minerals such as pyrite have oxidized into limonite and hematite, giving the rock a rusty appearance. The oxidation process released gold which was encapsulated in the original pyrite grains or carbon, making it amenable to cyanide leaching. Argillization is strongest in fault zones, and even where strong has generally been incomplete. Limestone occurs as breccia clasts and large blocks between faults within most of the oxidized ore. Refractory carbon and arsenic sulfide minerals such as orpiment and realgar that were present in un-weathered ore have been oxidized. Remnant pods of refractory carbonaceous ore can be found as irregular pods within the oxidized ore and as deeper zones that were insulated from supergene oxidation processes.
- **Silicified ore:** Silicification is present in all the deposits at Gold Bar but is most common at GBS. Silicification is not always gold bearing, suggesting that some of it formed before or after the gold mineralizing event. Silicified ore is brittle and commonly highly fractured, and internal breccia textures indicate multiple periods of silicification. Silicified ore is generally oxidized at both GBN and GBS. Silicification occurs in fault zones but can also replace favorable stratigraphic units such as the Kobeh member of the McColley Canyon Formation. At GBS silicification has mostly affected the Horse Canyon Formation, where it is highly fractured and brecciated.
- **Unoxidized refractory ore:** Refractory ore consists of variably decarbonated, argillized, silicified, sulfidic, carbonaceous sedimentary rocks that contain disseminated iron and arsenic sulfide minerals. In refractory ore in most Carlin-type deposits, gold occurs as extremely fine sub-micron particles in arsenian pyrite rims surrounding older barren pyrite grains. Gold contained within pyrite is not available to be recovered by cyanide solutions, which makes the ore not suitable for heap leaching. Carbon in refractory ore may be preg-robbing, also making it unsuitable for heap leaching.

**GOLD BAR PROJECT**  
**S-K 1300 TECHNICAL REPORT SUMMARY**

---

At GBN, unoxidized refractory mineralization is typically black due to re-mobilized soft carbon and contains fine-grained pyrite and variable amounts of realgar and orpiment. Refractory mineralization at GBN is typically also argillized and decarbonated. Unoxidized mineralization occurs as pods within oxidized ore, and also as larger deeper zones where supergene weathering processes have not reached it. No unoxidized refractory ore has been identified at GBS.

## **7 EXPLORATION**

Extensive exploration work in the Gold Bar camp was initiated by Atlas, which led to the discovery of the GBN project area resources. In addition to drilling, this work consisted of rock and soil geochemical sampling, regional and detailed geologic mapping, underground exploration, and limited geophysical exploration. Companies in partnership with Atlas in the 1990's completed additional work including drilling and geophysics as discussed in Section 5.

Soon after McEwen acquired the project in 2007, exploration continued with drilling, mapping and soil and rock geochemical sampling. Several exploration targets identified by previous companies were followed up by McEwen with drill testing. McEwen also identified resource expansion targets in and near the Gold Pick, Cabin Creek and Gold Ridge deposits. These were drilled extensively beginning in 2007, ultimately resulting in the definition of additional mineral resources and mineral reserves for the 2015 feasibility study. McEwen also identified gaps in the geologic mapping and geochemical data on the property, and in 2007 began a program of soil and rock sampling complemented by geologic mapping. This work identified several new exploration targets, some of which were subsequently drilled. After the 2015 feasibility study was completed, exploration work at GBN largely came to a stop. When the initial Record of Decision for the Mine Plan of Operations was issued by the BLM in late 2017, McEwen reactivated exploration on the project. In addition to drilling, McEwen expanded soil and rock geochemical coverage, launched a program of detailed geologic mapping, conducted spectral analysis and significantly increased geophysical coverage over the GBN and GBS project areas.

The motivation for continued exploration in the immediate pit areas and over the entire property was the recognition by McEwen that the greater Gold Bar camp is very prospective for discovering additional gold mineralization, containing numerous key components common to districts endowed with large Carlin-type gold systems.

These include in part:

- Significant and proximal regional gold endowment
  - Clustered, camp-scale deposits
  - Located on a major, well-recognized and documented gold trend
- Major through-going, large displacement faults within the camp
  - Strong faulting and fracturing of favorable host rocks
- Structural traps for hydrothermal fluids
  - Roberts Mountains Thrust
  - WNW anticline associated with deposits
- Favorable host rocks
  - Slope facies, reactive Devonian carbonate section
  - Low-angle stratigraphic controls / permeability contrasts
- Target-type alteration
  - Widespread decarbonatization, silicification and argillic alteration in multiple favorable host rocks



- Widespread anomalous gold+arsenic+antimony+mercury±thallium±silver geochemistry in soil and rock samples
- Intrusive rocks of multiple ages

## **7.1 GEOCHEMICAL EXPLORATION**

Predecessor companies and McEwen collected more than 10,000 rock samples and 17,000 soil samples over the Gold Bar property, including both GBN and GBS. Much of this sampling was done in the deposit areas and helped define targets for further exploration. Rock and soil samples were analyzed for gold and geochemical trace elements including Ag, As, Hg, Sb and Tl. Rock samples displaying gold data are shown on a map in Figure 7-1. Soil samples displaying gold data are shown on a map in Figure 7-2. Geochemical samples were used to guide exploration and were not used in estimating the resource.

### **7.1.1 Previous Companies**

Antecessor companies collected some 11,000 soil samples throughout the Gold Bar property. Sampling was largely focused on specific targets in the greater GBN and GBS project areas. Soil samples were collected on grid patterns, with the spacing between samples ranging from 30 x 30 meters to 100 x 100 meters. Soils were analyzed for gold, but not all legacy samples were analyzed for key trace elements such as Ag, As, Hg, Sb and Tl. Before McEwen acquired the property, 7,300 rock samples were collected, most by Atlas. After the haul roads were constructed between the original Gold Bar plant site and the satellite pits in Pick area, Atlas systematically collected road cut samples of the new exposures.

### **7.1.2 McEwen Work**

McEwen identified significant gaps in the rock and soil geochemical coverage and began a sampling program soon after acquiring the property in 2007. Initial soil grids were laid out in patterns of 100 x 100 meters over prospective areas where no previous sampling had been enacted. In areas where more detailed coverage was required, 30 x 30-meter grids were sampled. McEwen collected some 6,000 soil samples and 2,700 rock samples. In addition to outcrop sampling, roads cut for exploration drill access and trenches provided new exposures and were sampled. This work resulted in the discovery of new geochemical anomalies and identified new exploration target areas. Some of these targets were followed-up with additional work including drilling and some remain unexplored.

Soil geochemical sampling was carried out over an extensive period of time, with different companies using different analytical techniques and detection limits. The resulting data set thus contains mixed analytical data that needed processing in order to be useful. These data were compiled, validated, and levelled so they could be used effectively in as an integral component in target definition and identification (Heberlein, 2017 and 2018).

A set of drill samples collected from the Gold Bar district deposits and surrounding areas were analyzed for carbon and oxygen isotopes with the goal of mapping hydrothermal depletion anomalies. Mineralizing fluids preferentially removed the oxygen 18 isotope ( $^{18}\text{O}$ ) from the carbonate rocks and have been used extensively as a tool to map fluid flow in other Carlin-type districts. The set of samples collected by McEwen in 2019 proved the Gold Bar samples are depleted in  $^{18}\text{O}$ , indicating that hydrothermal fluids flowed extensively throughout the district including areas well beyond the known gold deposits. The density of the initial sampling program, however, was too low to provide enough data for 3D modelling and vectoring (Heberlein, 2019).

## **7.2 GEOLOGIC MAPPING**

### **7.2.1 Previous Companies**

Previous companies, mainly Atlas, carried out geologic mapping throughout the Gold Bar property. The areas around the gold deposits were mapped in more detail than the outlying areas. White Knight measured stratigraphic sections throughout the GBN area. The GBS area was mapped by several predecessor companies.

### **7.2.2 McEwen Work**

McEwen mapped the area between GBN and GBS in detail, including outcropping lithology, alteration, formations, and structures. New exposures in active and recent mining pits, road cuts and new trench exposures were also mapped and included in the property-wide compilation. This work greatly improved the geological understanding of the gold deposits, and significantly improved the quality of the geologic model used to calculate new resources and reserves. The current project-wide geologic map is shown in Section 6, Figure 6-1 Detailed geologic mapping in the Gold Pick, Gold Ridge and Gold Bar South areas incorporated new exposures from active mining areas, exploration road cuts and trenches. Combining the results of this work with the drill data, the role structure plays in focusing mineralization is understood to be much more significant than was previously recognized.

## **7.3 GEOPHYSICAL EXPLORATION**

Companies who worked at Gold Bar before McEwen implemented geophysical work consisting of Controlled-Source Audio frequency Magneto-Tellurics (CSAMT), using it mostly to explore the bedrock surface under alluvial cover around the original Gold Bar mine. However, the core of the district covering the GBN deposit areas was largely unevaluated by geophysics.

In 2011, McEwen executed a detailed high-resolution airborne survey over the GBN area using multiple geophysical methods including Z-Axis Tipper Electromagnetic (Z-TEM), magnetics, resistivity, Electromagnetic (EM), radiometrics and hyperspectral imaging. McEwen completed extensive CSAMT and gravity surveys and acquired a complete set of aeromagnetic data over the entire project area in 2018 and 2019. All the geophysical data acquired by McEwen were validated and compiled into a comprehensive district-wide CSAMT, gravity and magnetics database which has proven invaluable in developing exploration targets and supporting camp- and deposit-scale geological models.

### **7.3.1 CSAMT**

After Atlas stopped mining, they formed ventures with companies who completed about 104 line-km of CSAMT over the project area in the valley around the original Gold Bar mine and eastward to just past the Wall Fault (Figure 7-3). The original Gold Bar mine lies on a northwest-trending horst of Devonian bedrock faulted against thick alluvium and volcanic rocks on either side. The CSAMT data show the bedrock surface very well and were used to guide exploration drilling. In addition, CSAMT mapped resistivity contrasts associated with alteration well, such as strong silicification associated with major faults, e.g., the Wall Fault.

McEwen contracted about 130 line-km of CSAMT surveys in 2018 and 2019, completing coverage over much of the project area around the deposits. The CSAMT data were inverted and displayed as scaled cross sections, and as depth slices in some areas. The sections allow the interpretation of faults and structures based on resistivity contrasts. The major faults in the district such as the Wall, Cabin and Roberts Creek faults are clearly visible and mappable with CSAMT. A map showing all the CSAMT sections on the Gold Bar project, rotated to plan, is shown in Figure 7-3.

In addition to large faults, argillic alteration can appear as resistivity lows, providing exploration targets. A strong CSAMT-low-resistivity anomaly east of Gold Pick was identified, suggesting alteration down-dip from the known

deposit. Three holes were drilled into the anomaly, and two of them intersected gold in decarbonated and argillized limestone.

### **7.3.2 Gravity**

Atlas and their venture partners completed gravity surveys in the area of the original Gold Bar mine. Used in tandem with CSAMT, gravity helped map areas of shallow bedrock along the horst. Most of Atlas' gravity work was in pediment areas to help map the bedrock surface under variable thicknesses of alluvium and volcanic cover.

In 2018 and 2019 McEwen undertook an extensive program of gravity data acquisition covering most of the Gold Bar property, including the areas around the known deposits at Pick, Ridge and Cabin Creek that were not covered in previous surveys. Spacing between gravity stations ranges from a staggered 200-meter grid over the deposit areas to a 400-meter grid over the remaining areas. A map showing gravity stations is shown in Figure 7-4. Figure 7-5 shows horizontal gradient gravity which is excellent for mapping structure. Displayed in Figure 7-6 is a map showing the residual gravity. In addition to helping refine the locations of the known major faults, gravity also identified structures not visible on the surface.

### **7.3.3 Magnetics**

McEwen purchased detailed aeromagnetic data covering the Gold Bar camp. The Northern Nevada Rift (NNR), a north-northwest-trending regional zone of mafic volcanism and dikes, passes through the eastern portion of the Gold Bar property. A strong linear magnetic anomaly is associated with the NNR as illustrated in Figure 7-7. Importantly, immediately west of the NNR, underlying much of the Gold Bar project, is a subdued magnetic feature that is spatially associated with the gold deposits and soil anomalies. It is interpreted as a deeply buried intrusive body; plotted on Figure 7-7.

## **7.4 SPECTRAL EXPLORATION**

Since gold mineralization is often associated with argillic alteration, particularly various species of illite in Carlin-type deposits, spectral methods were used to identify areas of clay alteration that could lead to exploration targets. In 2018, McEwen contracted an interpretation and field validation of a high-resolution Airborne Visible Infrared Imaging Spectrometer (AVRIS) aerial spectral survey covering most of the Gold Bar property. The purpose of this was to map occurrences of clay and other alteration minerals with a twofold goal: first, to identify clay species associated with areas of known gold mineralization at GBN, and secondly, to directly define exploration targets or, indirectly, hydrothermal fluid pathways vectoring toward covered targets. The initial program was expanded to include downhole spectral scans of reverse circulation chips and core on camp-scale cross sections to better define possible hydrothermal fluid pathways.

A map showing the spectral mineral distribution is shown in Figure 7-8. An interpretative spectral cross section integrating downhole spectral data with the structural framework and interpreted fluid pathways is shown in Figure 7-9.

A spectral study was also completed on four metallurgical core holes at Cabin Creek to identify clay mineralogy and provide a guide to measuring clay intensity of the altered intervals.

## **7.5 UNDERGROUND EXPLORATION**

Atlas drove an exploration adit north and west into the north wall of the Gold Pick East pit, for a length of about 672 ft. This work was completed in 1994, during the late stages of mining. The purpose of the drifting was to define areas with potential to expand reserves but could not be effectively drilled from surface. Four drill stations were set up underground within the north wall of the pit, where 55 reverse circulation (RC) holes were drilled for a total of 9,464 feet. A second phase of underground mining, contingent on the results of the first phase, was to extend the drift to the

**GOLD BAR PROJECT**  
**S-K 1300 TECHNICAL REPORT SUMMARY**

---

west and southwest of the Gold Pick East pit to develop high grade mineralization there. Results of the first phase confirmed and expanded known mineralization but did not identify enough high-grade mineralization suitable for underground mining. The second phase was never activated. Total gold produced during the drifting operation was 86 ounces.

Also, in 1994, Atlas drove an adit from the bottom of the Goldstone pit into the north wall to evaluate high-grade zones of mineralization identified by surface drill holes. Underground work consisted of 420 feet of drifting, followed by 4,878 feet of RC drilling in 28 holes. Seven drill hole fans were completed at the end of the drift, about 200 feet north of the pit bottom. Each fan was drilled on its own azimuth, ranging from south-southeast to north-northeast. Holes were drilled southeast at different inclinations along the same azimuth on each fan. With encouraging underground drill results in-hand, the drift was extended into what was modelled as a tabular-shaped high-grade zone. Instead, the high-grade zone was found to be "V"-shaped, controlled by faults, lower grade and much narrower than expected. After extending the drift to daylight in the Goldstone pit, Atlas abandoned underground mining. Total gold produced from underground development and mining at Goldstone was 281 ounces.

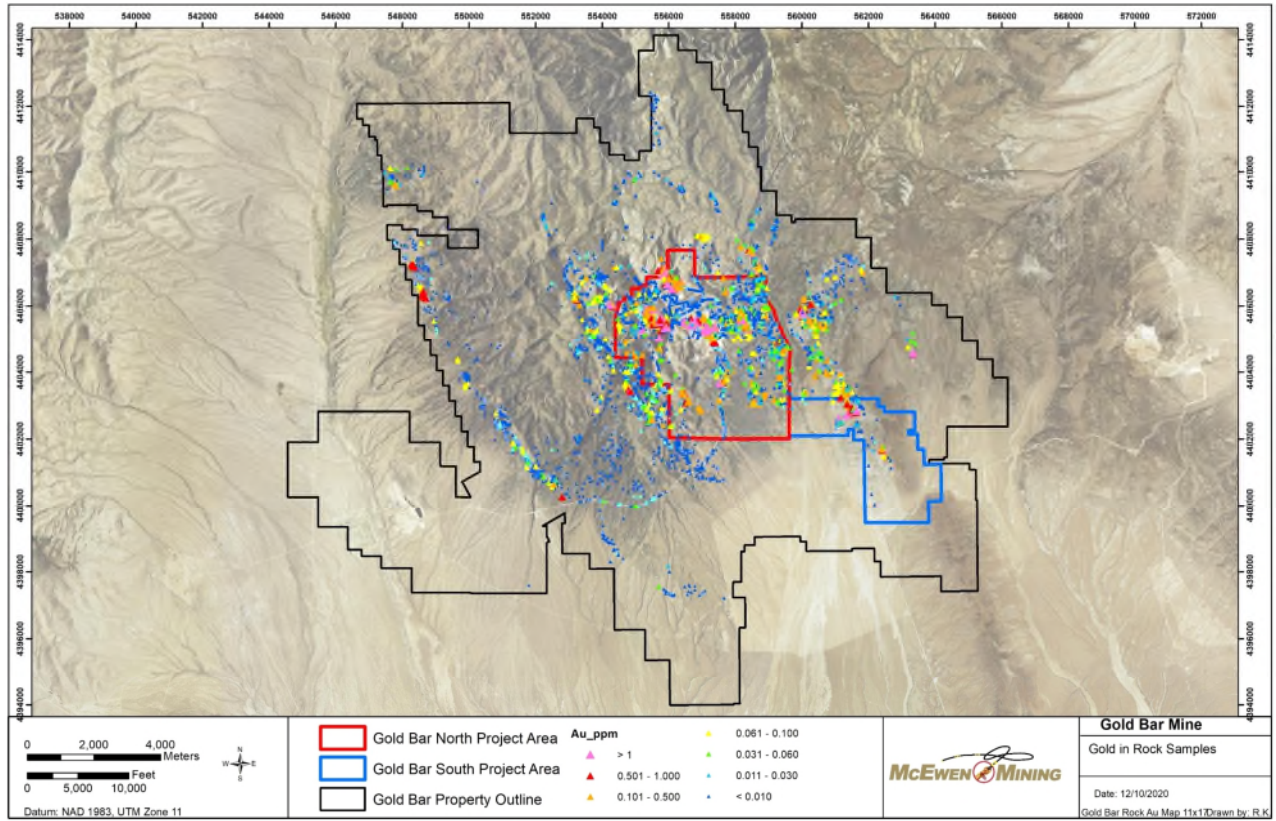


Figure 7-1: Gold in Rock Samples

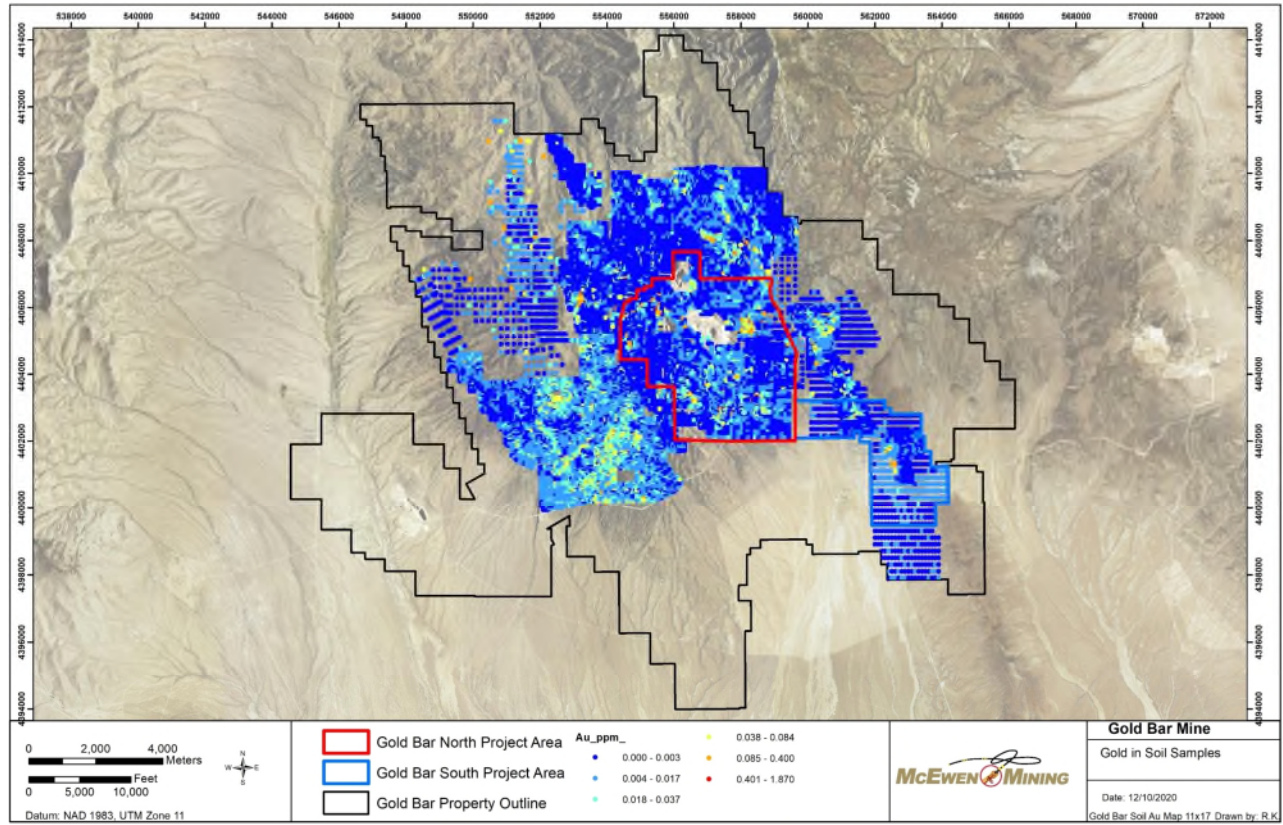


Figure 7-2: Gold in Soil Samples

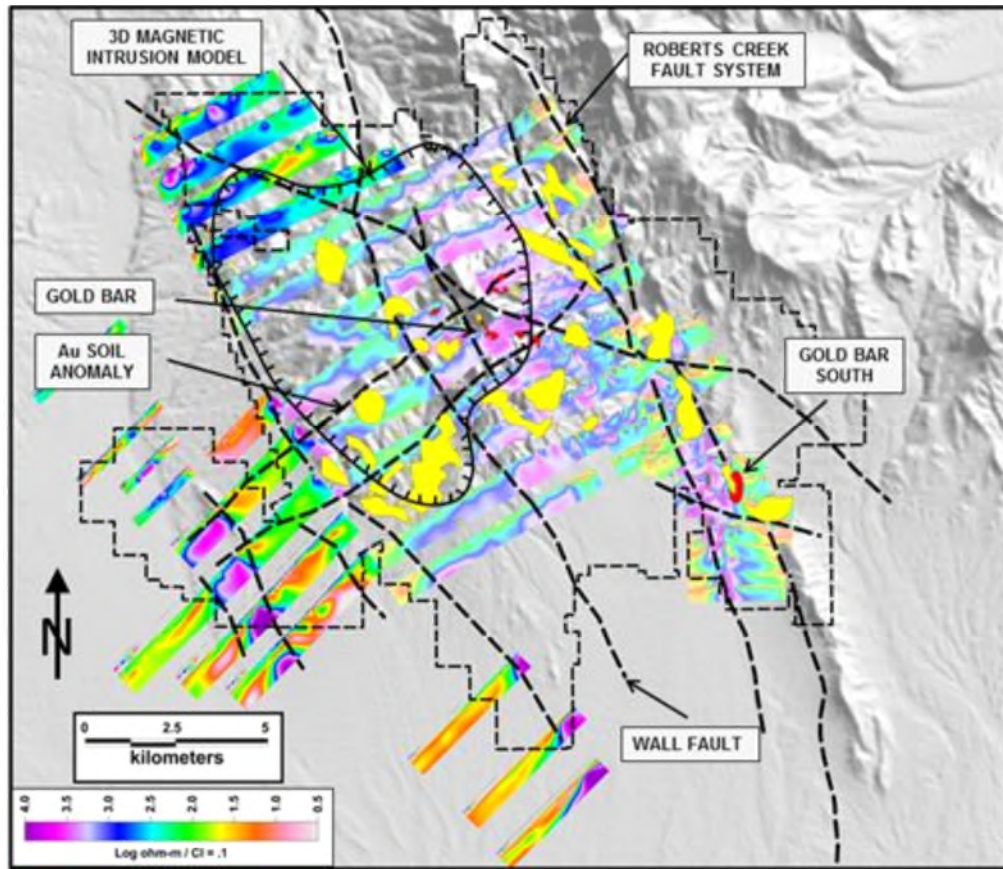


Figure 7-3: CSAMT Inverted Sections Rotated to Plan (Kastelic et al., 2020)

High angle and low angle faults are marked by contrasting resistivities. The Wall and Roberts Creek faults appear on the sections. Deposits shown as red polygons.

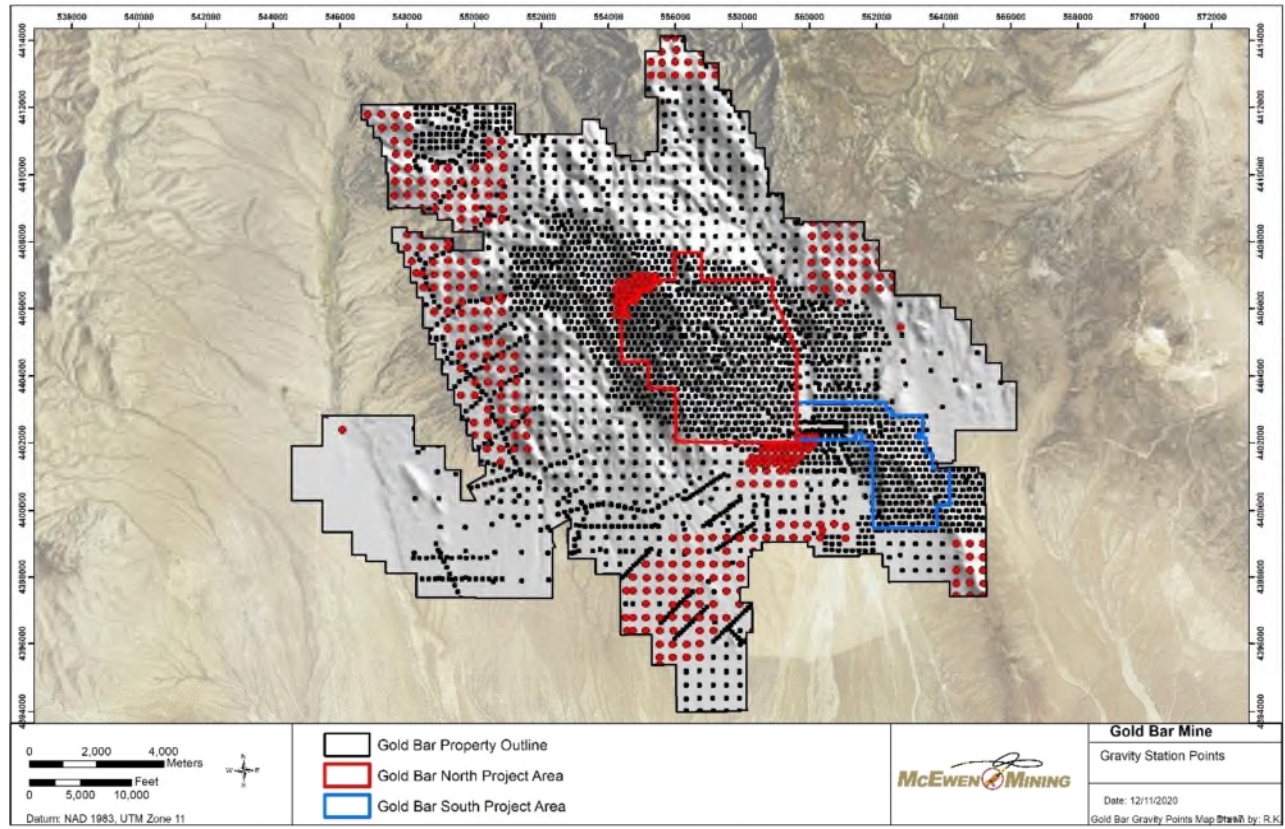
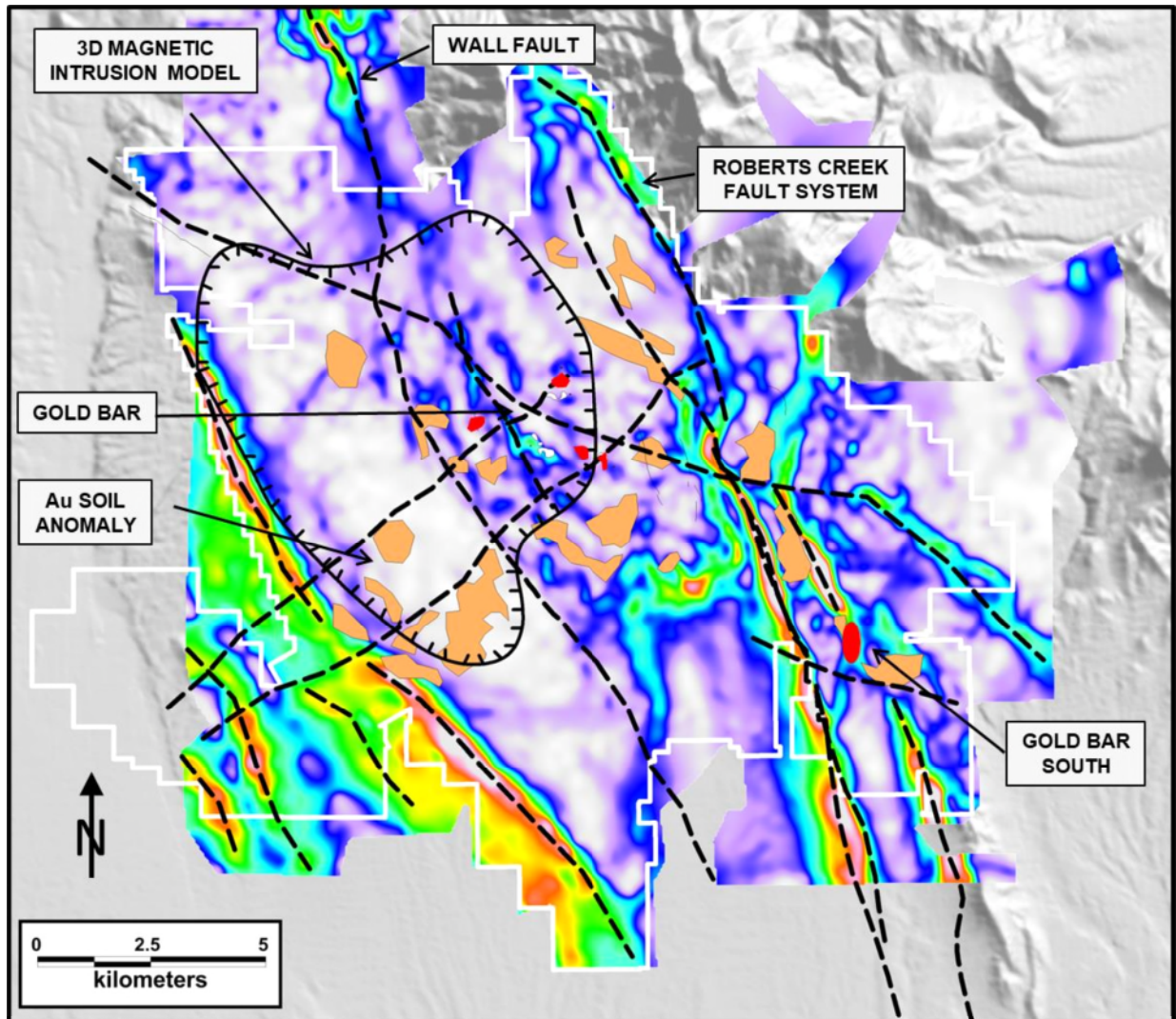


Figure 7-4: Gravity Stations in Red and Black



Gravity stations spaced 200 meters apart in GBN and GBS areas, and 400 meters in remaining areas.



**Figure 7-5: Horizontal Gradient Gravity Showing Major Structural Trends in the Gold Bar District (Kastelic et al., 2020).**

Gold-in-soil anomalies shown as orange polygons. White outline is property boundary.

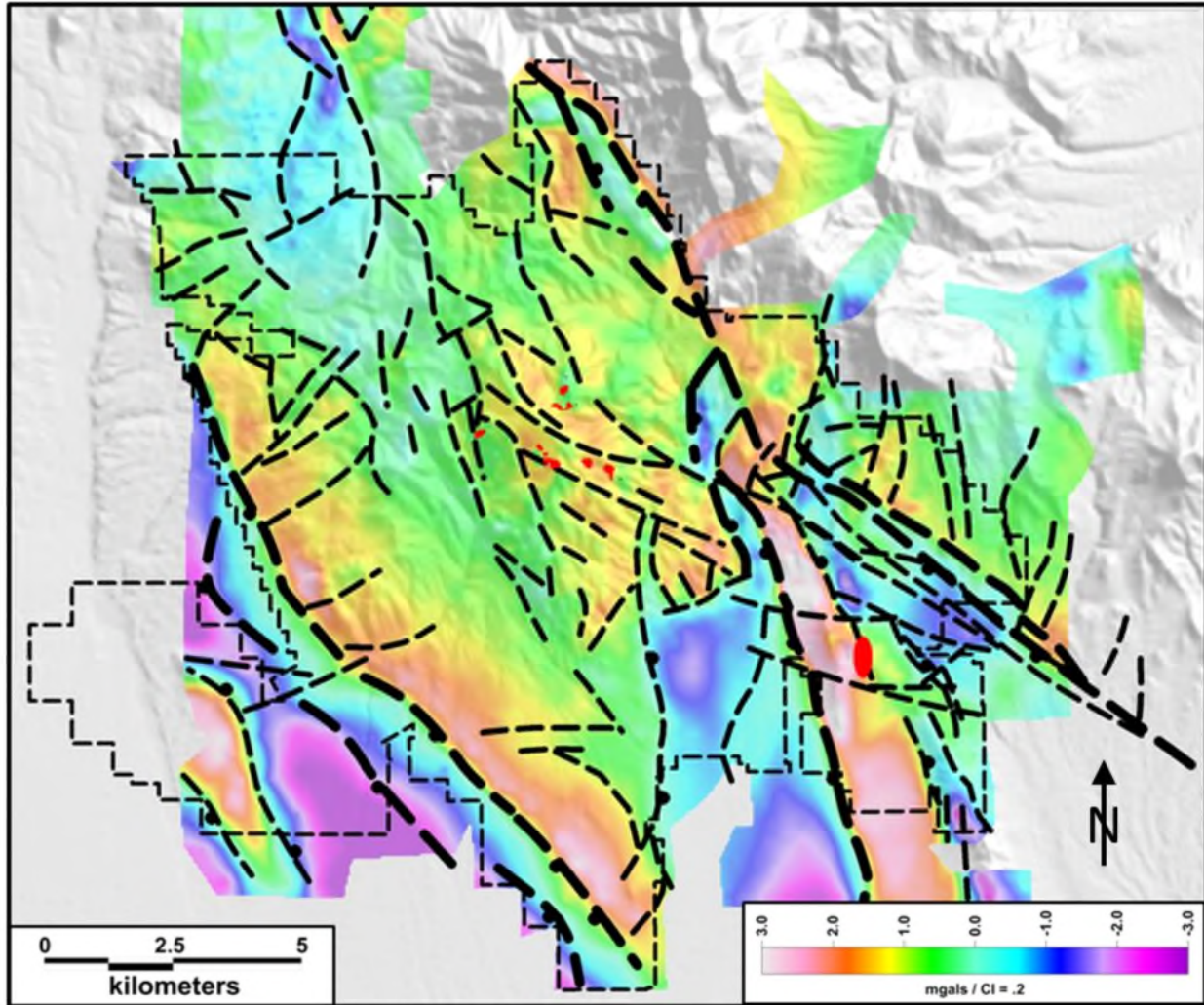


Figure 7-6: Residual Gravity Map of the Gold Bar Property. (Kastelic et al. (2020))

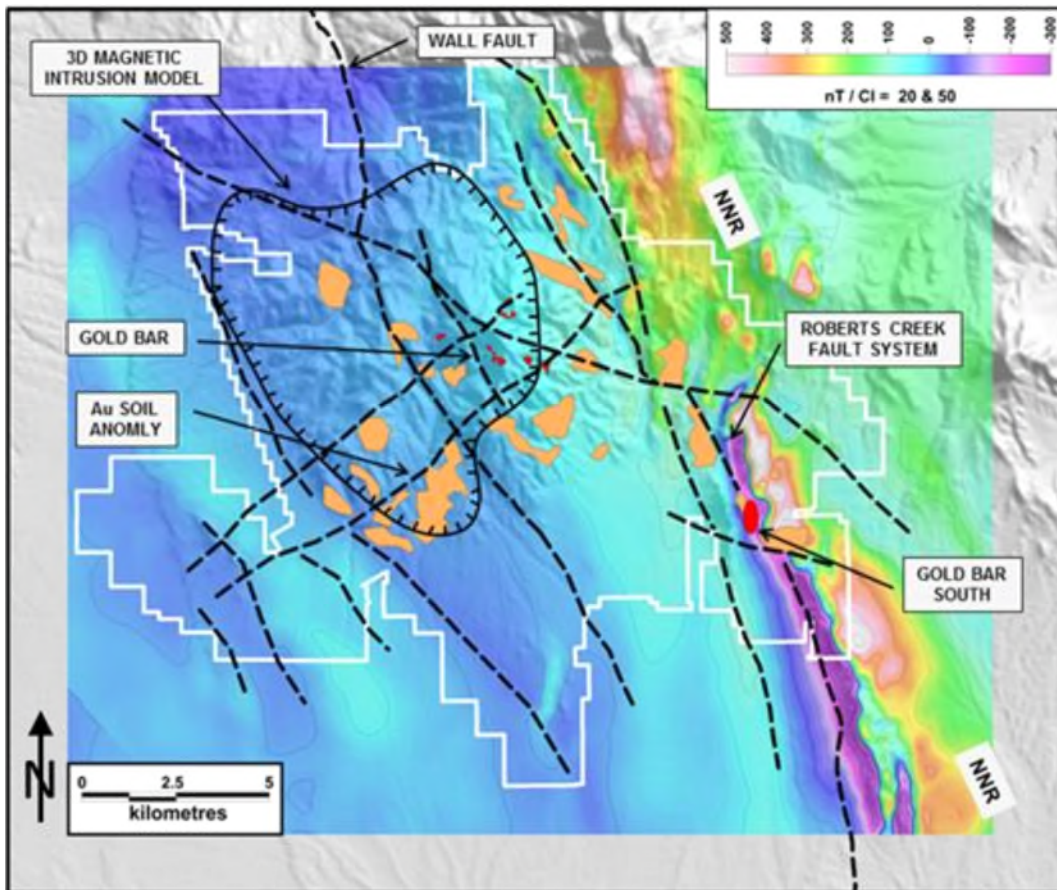


Figure 7-7: Reduced to Pole Magnetics Map of the Gold Bar District. (Kastelic et al. (2020))

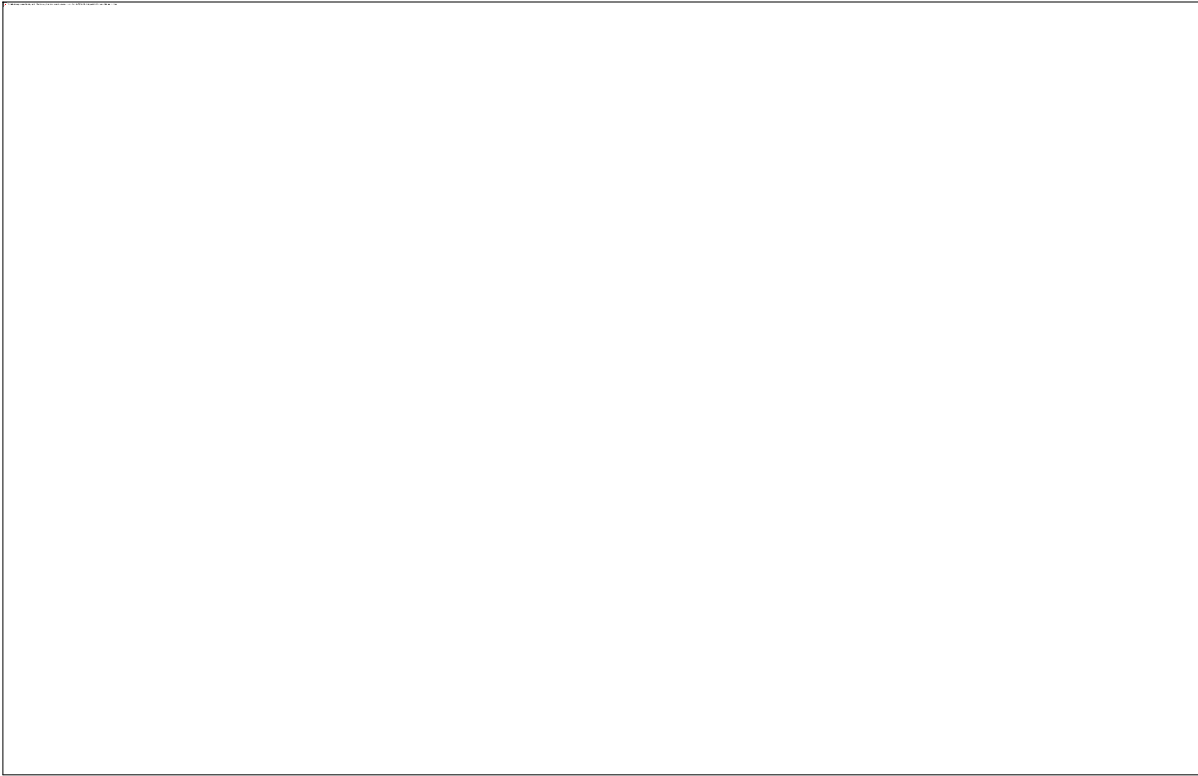


Figure 7-8: Spectral Mineral Map of Gold Bar Property.

**GOLD BAR PROJECT**  
**S-K 1300 TECHNICAL REPORT SUMMARY**

---

Illite anomalies are strong over the mined areas where clays have been exposed. Ammonium illite, in orange, is associated with siliceous and silicified rocks.

The location of the cross section in Figure 7-9 is shown by the section line A-A' in Figure 7-8.

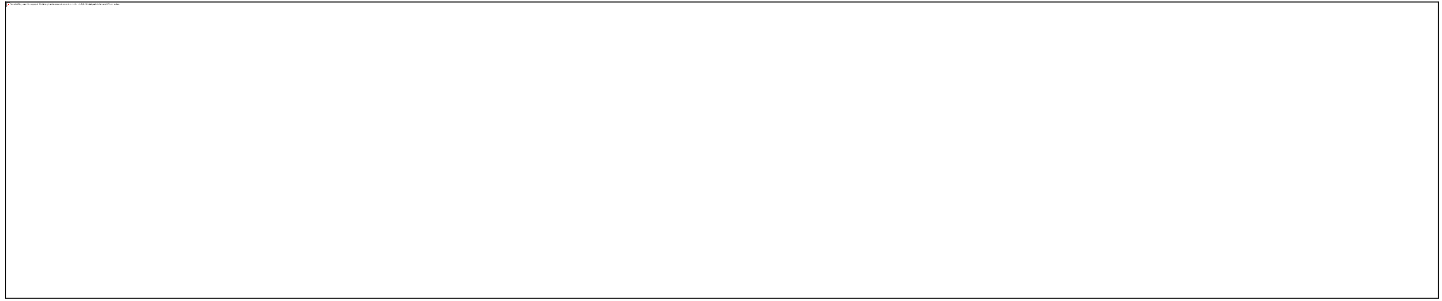


Figure 7-9: Interpretative Spectral Cross Section through the Gold Bar District, looking NNE (Geospectral Solutions, 2020).

**GOLD BAR PROJECT**  
**S-K 1300 TECHNICAL REPORT SUMMARY**

Interpretation of drill hole spectral data showing mineralizing fluids migrating up faults (blue arrows) into favorable McColley (Dmc) and upper Denay 2 (Dud2) limestone. The line of section is shown on Figure 7-9.

**7.6 DRILLING**

**7.7 TYPE AND EXTENT**

**7.7.1 Gold Bar North**

More than 95% of the drill holes supporting the GBN mineral resource estimates are reverse circulation (RC). The rest are HQ and PQ-diameter core drilled primarily for geological, geotechnical, and metallurgical studies. A map showing all holes drilled on the Gold Bar property is shown in Figure 7-10.

In 2021, 8 oriented HQ core holes were drilled to acquire data for better understanding of the controls to mineralization at Gold Ridge. An additional 8 oriented HQ core holes were completed for metallurgical analyses and three HQ core holes were completed for geotechnical purposes. The Project drilling history is summarized in Table 7-1, which includes drill holes shown in Figure 7-10 and Figure 7-11.

In Q4 2010 and Q1 2011 McEwen enacted a drilling program to support metallurgical and geotechnical studies. This drilling was completed by Boart Longyear, based in Elko, Nevada, Ruen Drilling based in Clark Fork, Idaho, and DOSECC Exploration Services based in Salt Lake City, Utah. An additional metallurgical program was completed at Cabin Creek in Q2 2018, drilled by Boart Longyear, based in Elko, Nevada. In total, seventeen holes were drilled for metallurgical test purposes (GBM01-GBM13 and GBM16-GBM19) and eight holes were drilled for geotechnical purposes (GBT01-GBT08). Statistics for these drill holes are provided in Table 7-2. Metallurgical drill holes (“GBM”-series) were used to develop leach recovery projections, to provide density determinations and to validate previous RC drilling. Geotechnical data were collected from HQ-sized oriented core (“GBT”-series) which were analyzed to characterize rock mass strength and support pit slope angle designs for mine planning.

**Table 7-1: Drilling History at Gold Bar North**

| <b>Project Phase</b>                   | <b>Number of Holes</b> | <b>Total Feet Drilled</b> |
|--|------------------------|---------------------------|
| Pre-2007                               | 2,403                  | 994,292                   |
| McEwen * 2007-2010                     | 160                    | 112,108                   |
| McEwen * 2010-11 Met/Geotech           | 17                     | 7,551                     |
| McEwen 2015 Infill/Upgrade             | 38                     | 13,365                    |
| McEwen 2017 Infill/Upgrade             | 16                     | 9,980                     |
| McEwen 2018 Infill/Upgrade/Met         | 63                     | 42,675                    |
| McEwen 2019 Infill/Upgrade             | 75                     | 36,070                    |
| McEwen 2020 Infill/Upgrade             | 179                    | 67,725                    |
| McEwen 2021 Infill/Upgrade/Geotech/Met | 53                     | 13,767                    |
|  | <b>3,004</b>           | <b>1,297,533</b>          |

Source Atlas, McEwen 2021

\* McEwen was incorporated as US Gold at this time

**Table 7-2: Locations of 2010-2011, 2018 McEwen GBN Metallurgical and Geotechnical Drill Holes**

| Hole ID | Hole Type | Area Name   | Easting (ft) | Northing (ft) | Elevation (ft) | Depth (ft) |
|---------|-----------|-------------|--------------|---------------|----------------|------------|
| GBM01   | Core      | Gold Pick   | 1827323      | 14452808      | 7974           | 508        |
| GBM02   | RC        | Gold Ridge  | 1823181      | 14454882      | 8454           | 346        |
| GBM03   | Core      | Gold Pick   | 1825705      | 14453720      | 8481           | 623        |
| GBM04   | Core      | Gold Pick   | 1828344      | 14452648      | 7940           | 722        |
| GBM05   | Core      | Gold Pick   | 1828342      | 14452649      | 7941           | 582        |
| GBM06   | Core      | Cabin Creek | 1832477      | 14453154      | 7232           | 343        |
| GBM07   | Core      | Gold Pick   | 1827812      | 14453071      | 7628           | 170        |
| GBM08   | RC        | Gold Ridge  | 1823066      | 14455289      | 8578           | 230        |
| GBM09   | Core      | Cabin Creek | 1831938      | 14452800      | 7261           | 258        |
| GBM10   | RC        | Gold Pick   | 1826873      | 14452612      | 8104           | 560        |
| GBM11   | RC        | Gold Pick   | 1826801      | 14452568      | 8099           | 685        |
| GBM12   | RC        | Gold Ridge  | 1822265      | 14455473      | 8618           | 345        |
| GBM13   | Core      | Cabin Creek | 1832127      | 14453195      | 7199           | 424        |
| GBM16   | Core      | Cabin Creek | 1831176      | 14453994      | 7404           | 81         |
| GBM17   | Core      | Cabin Creek | 1831180      | 14453994      | 7404           | 135        |
| GBM18   | Core      | Cabin Creek | 1831396      | 14453993      | 7394           | 80         |
| GBM19   | Core      | Cabin Creek | 1832029      | 14453117      | 7241           | 320        |
| GBT01   | Core      | Gold Pick   | 1827828      | 14453141      | 7640           | 216        |
| GBT02   | Core      | Gold Ridge  | 1823153      | 14455421      | 8664           | 449        |
| GBT03   | Core      | Cabin Creek | 1831938      | 14452802      | 7263           | 198        |
| GBT04   | Core      | Gold Pick   | 1826196      | 14453314      | 8278           | 574        |
| GBT05   | Core      | Gold Pick   | 1825479      | 14453538      | 8582           | 591        |
| GBT06   | Core      | Gold Pick   | 1827836      | 14453146      | 7632           | 493        |
| GBT07   | Core      | Gold Pick   | 1826182      | 14453384      | 8265           | 658        |
| GBT08   | Core      | Cabin Creek | 1832431      | 14452995      | 7170           | 492        |
| Total   |           |             |              |               |                | 10,082     |

Source: McEwen 2020

- Easting and Northing coordinates are UTM NAD83 feet
- Elevation is in feet above mean sea level.

In 2015, 38 RC holes were drilled in Gold Pick West by McEwen to upgrade Inferred Mineral Resources to Measured and Indicated to improve economic projections. The drilling contractor for this program was National EWP, based in Elko, Nevada. During this drilling campaign, 13,365 ft of RC drilling were completed, which intersected approximately 1,350 ft of mineralized material at an average grade of 0.04 oz/t gold. Real-time hand-held XRF logging of arsenic was used in the field as a proxy for gold to help guide the drill planning.

Drilling resumed at GBN in late 2017 and continued through 2021. From 2017-2021, 333 RC holes and 45 oriented core holes were drilled, totalling 173,884 feet. Collar locations for these holes are shown on Figure 7-11, broken out by year drilled.



## **GOLD BAR PROJECT**

### **S-K 1300 TECHNICAL REPORT SUMMARY**

---

Efforts in 2017 and 2018 were aimed at expanding mineralization at West Pick, Cabin Creek and Gold Ridge NW. Part of this program included four metallurgical holes completed at Cabin Creek, which are tabulated in Table 7-2.

In 2019, drilling at GBN was largely exploring new zones of mineralization outside the deposit boundaries. This is illustrated by the scatter of 2019 holes shown on Figure 7-11.

The 2020 program focused on West Pick. It was designed to meet several objectives using a mix of oriented core and RC holes to complement recent highwall mapping and provide the foundation for a robust 3D geologic model, which in turn would support the resource model. These goals were:

- De-risk current mining areas;
- Define structural controls with targeted oriented angle core holes;
- Infill drill gaps in and proximal to the resource;
- Upgrade the inferred resource; and
- Increase the number of density samples.

A total of 79 holes were completed in 2020 for a cumulative 67,725 feet, seventeen of these holes were oriented HQ core (7,335 feet). These holes are shown on Figure 7-11 and Figure 7-12.

Drilling companies in 2020 were DeLong Construction and Drilling from Winnemucca, Nevada, National EWP from Elko Nevada, and HD Drilling, also from Winnemucca. DeLong and Boart Longyear of Elko, Nevada, also drilled at GBN in 2018 and 2019. Boart Longyear of Elko, Nevada was the contractor for the 2017 drilling.

The 2021 program dominantly focused on Gold Ridge and Cabin North. At Gold Ridge, drilling was designed to better define and extend mineralization in the northern portion of the deposit, provide samples for metallurgical test work, and provide geotechnical information for highwall stability. Drilling at the Cabin North deposit was designed to refine controls to mineralization and expand mineralization at depth and to the north of the deposit.

A total of 36 holes were completed at Gold Ridge in 2021 for a cumulative 13,750 feet. Drilling consisted of 17 reverse circulation holes for 7,880 feet, eight oriented core for cumulative 2,571 feet, eight metallurgical HQ/PQ core holes for cumulative 2,048 feet, and three HQ geotechnical core holes for a total of 1,251 feet. At Cabin North, a total of 16 HQ core holes were completed for a cumulative 3,435 feet.

Drilling companies utilized in 2021 were Timberline Drilling from Elko, Nevada, DrillRite from Spring Peak, Nevada, Premier Drilling from Elko, Nevada, and Nasco Industrial Services and Supply (NISS) from Kellogg, Idaho.

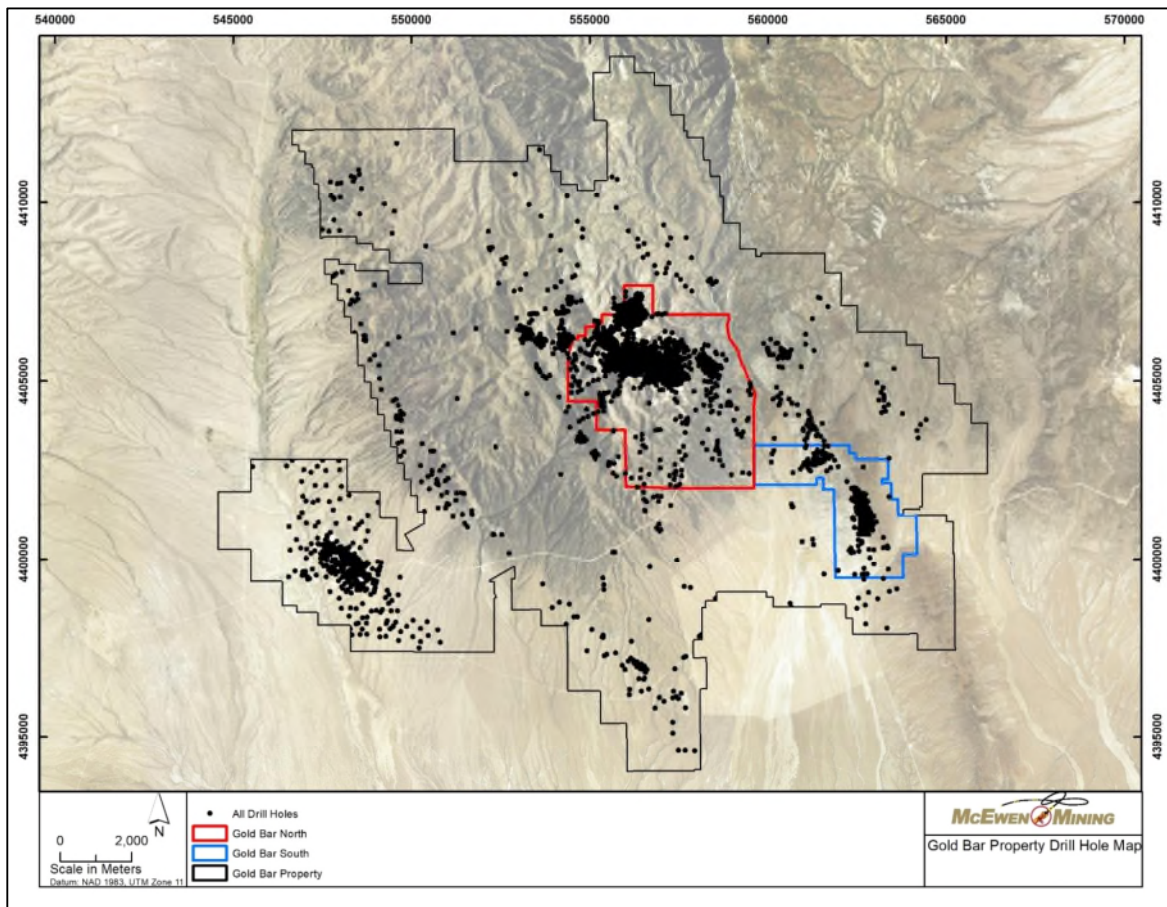


Figure 7-10: Gold Bar Property Drill Hole Map

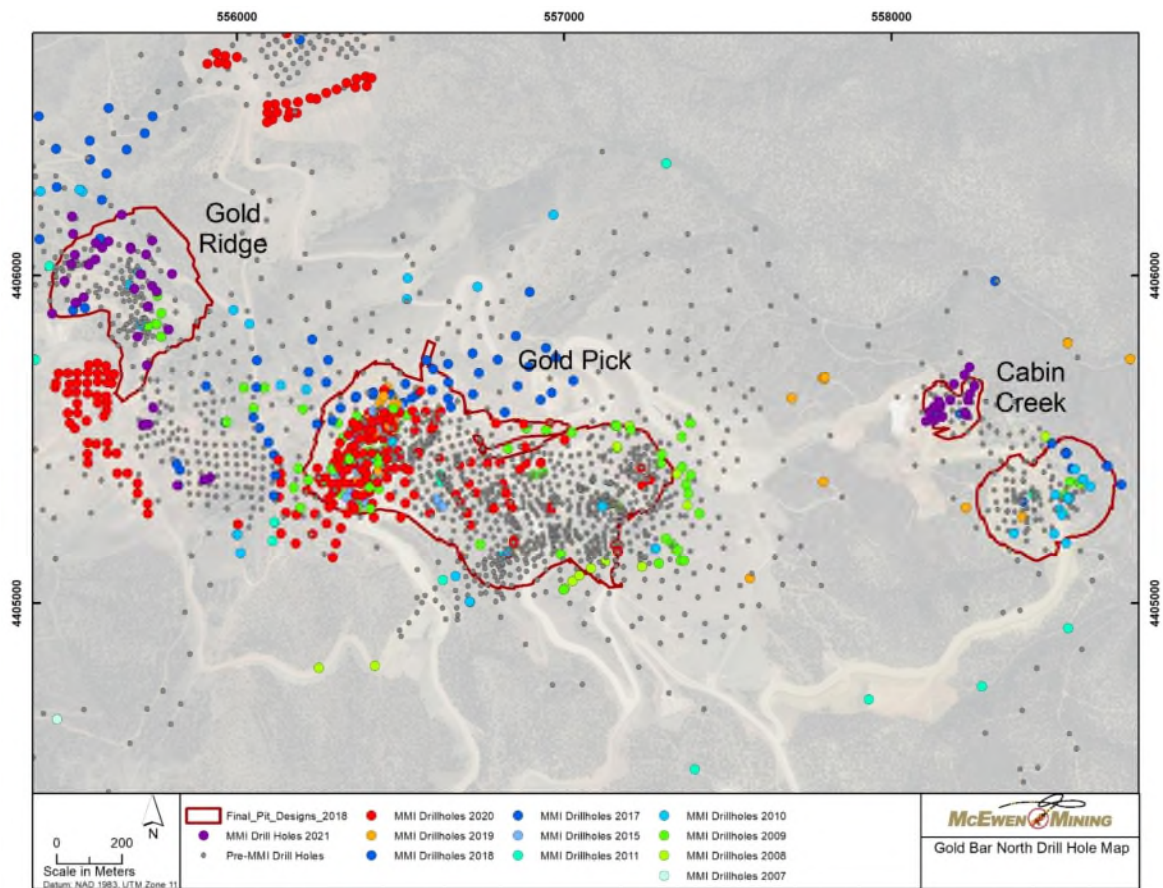


Figure 7-11: GBN Drill hole Location Map (Coordinates are UTM NAD 83 meters)

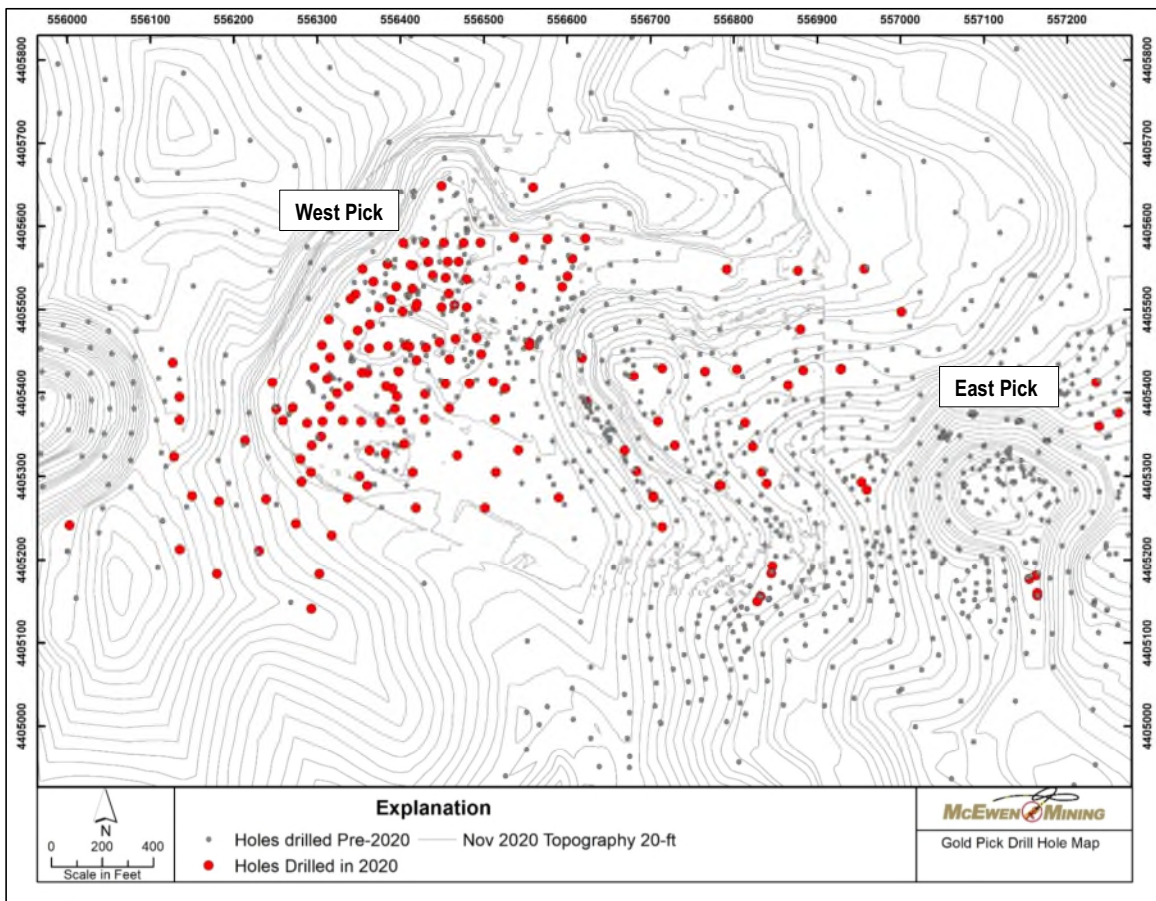


Figure 7-12: Gold Pick Drill hole Location Map (Coordinates are UTM NAD 83 meters)

**7.7.2 Gold Bar South**

Reverse circulation (RC) drill holes comprise 87% of the total holes and 86% of the total footage drilled to date at Gold Bar South (GBS). Approximately 5% of the total holes were completed with a rotary or air track drill rig early in the project's history with many of these holes located outside the resource area. Core holes were drilled in 1993, 2019 and 2020 for metallurgical, geotechnical, and geologic data and account for 7% of the holes drilled at GBS and 9% of the total footage. A summary of the GBS drilling history is presented in Table 7-3. McEwen acquired the property in 2016 and completed 12 RC holes for an aggregate 6,565 feet. McEwen resumed drilling at GBS in 2019 and 2020 with extensive RC and core drilling programs. Since the last Technical Report updating resources (SRK, 2015), 326 RC holes totalling 85,620 feet and 30 core holes totalling 10,125 feet were drilled (summarized in Table 7-3). The location of the drill holes relevant to the resource estimate is shown in Figure 7-13, with the recent holes highlighted. Most of the recent drill holes are in the Resource area with the remainder designed to test targets outside of the modeled area plus condemn the proposed dump area.

In 2019 McEwen completed PQ and HQ core drilling to support metallurgical and geotechnical studies for resource modelling and mine design, with additional metallurgical holes completed in 2020. The 2019 core drilling was completed by Boart Longyear, based in Salt Lake City, Utah and the 2020 core program was completed by Elko-based National EWP. In total, nine PQ core holes were drilled for metallurgical test purposes (GBS-MET01 to GBS-MET09) and five HQ core holes were completed for geotechnical purposes (GBS-GT01 to GBS-GT05). Statistics for these drill holes are provided in Table 7-4. Metallurgical drill holes ("GBS-MET"-series) were used to develop leach recovery projections and to validate previous RC drilling. Geotechnical data were collected from oriented HQ core ("GBS-GT"-series) which were analyzed to characterize rock mass strength and support pit slope angle designs for mine planning by Piteau Associates. McEwen collected samples for density determination from the 2019-2020 PQ metallurgical core and the sixteen HQ core holes completed in 2020 representing the different lithology and alteration types.

**Table 7-3: Drilling History at Gold Bar South**

| Company                                  | Year                 | Rotary           |              | RC                 |                | Air-track |            | Core      |               | Total Drill Holes | Total Footage  |
|--|----------------------|------------------|--------------|--------------------|----------------|-----------|------------|-----------|---------------|-------------------|----------------|
|  |                      | No.              | Feet         | No.                | Feet           | No.       | Feet       | No.       | Feet          |                   |                |
| Amselco                                  | 1981                 | 24               | 6,860        |                    |                |           |            |           |               | 24                | 6,860          |
| Hecla                                    | 1986                 |                  |              | 8                  | 2,850          |           |            |           |               | 8                 | 2,850          |
| LFC Trust                                | 1989-90 <sup>1</sup> |                  |              |                    |                | 9         | 994        |           |               | 9                 | 994            |
| Santa Fe                                 | 1988-89              |                  |              | 13                 | 5,130          |           |            |           |               | 13                | 5,130          |
| Phelps Dodge                             | 1990-91              |                  |              | 63                 | 15,640         |           |            |           |               | 63                | 15,640         |
| Great Basin                              | 1993                 | [2] <sup>2</sup> | 604          | 6+[1] <sup>2</sup> | 4,107          |           |            | 9         | 4,370         | 15                | 9,081          |
| Cominco                                  | 1996                 |                  |              | 16                 | 11,695         |           |            |           |               | 16                | 11,695         |
| Midway                                   | 2007                 |                  |              | 8                  | 3,250          |           |            |           |               | 8                 | 3,250          |
| NV Gold                                  | 2010                 |                  |              | 25                 | 7,803          |           |            |           |               | 25                | 7,803          |
| NV Gold                                  | 2011                 |                  |              | 23                 | 8,440          |           |            |           |               | 23                | 8,440          |
| McEwen, Step out                         | 2016                 |                  |              | 12                 | 6,565          |           |            |           |               | 12                | 6,565          |
| McEwen, Infill / Upgrade / Met / Geotech | 2019                 |                  |              | 209                | 47,765         |           |            | 10        | 2,240         | 219               | 50,005         |
| McEwen, Infill / Step out / Met          | 2020                 |                  |              | 82                 | 22,850         |           |            | 20        | 7,885         | 102               | 30,735         |
| <b>TOTAL</b>                             |                      | <b>24</b>        | <b>7,464</b> | <b>465</b>         | <b>136,095</b> | <b>9</b>  | <b>994</b> | <b>39</b> | <b>14,495</b> | <b>537</b>        | <b>159,048</b> |

Source: MDA, 2011, SRK, 2018 and McEwen, 2020.

<sup>1</sup> 15 air-track holes drilled in 1988 not included in database or Table 7-3

<sup>2</sup> Holes in [brackets] drilled as pre-collars to core holes.

<sup>3</sup> Holes drilled in 2019 and 2020 have not been previously reported in an NI 43-101 Mineral Resource Estimation.

**Table 7-4: Locations of 2019-2020 GBS McEwen Metallurgical and Geotechnical Drill Holes**

| Hole ID   | Hole Type | Area Name      | Easting (ft) | Northing (ft) | Elevation (ft) | Depth (ft) |
|-----------|-----------|----------------|--------------|---------------|----------------|------------|
| GBS-MET01 | Core      | Gold Bar South | 1846132      | 14439778      | 6939           | 285        |
| GBS-MET02 | Core      | Gold Bar South | 1845861      | 14439983      | 6967           | 80         |
| GBS-MET03 | Core      | Gold Bar South | 1845852      | 14440262      | 7016           | 125        |
| GBS-MET04 | Core      | Gold Bar South | 1845695      | 14440385      | 7013           | 90         |
| GBS-MET05 | Core      | Gold Bar South | 1845906      | 14441571      | 6883           | 365        |
| GBS-MET06 | Core      | Gold Bar South | 1845508      | 14440343      | 6974           | 120        |
| GBS-MET07 | Core      | Gold Bar South | 1846169      | 14439409      | 6866           | 320        |
| GBS-MET08 | Core      | Gold Bar South | 1846035      | 14439756      | 6930           | 325        |
| GBS-MET09 | Core      | Gold Bar South | 1845742      | 14440186      | 6985           | 130        |
| GBS-GT01  | Core      | Gold Bar South | 1845689      | 14441445      | 6932           | 250        |
| GBS-GT02  | Core      | Gold Bar South | 1845762      | 14441542      | 6913           | 300        |
| GBS-GT03  | Core      | Gold Bar South | 1846137      | 14439823      | 6947           | 222        |
| GBS-GT04  | Core      | Gold Bar South | 1846314      | 14439670      | 6927           | 285        |
| GBS-GT05  | Core      | Gold Bar South | 1845903      | 14440509      | 6988           | 240        |

Source: McEwen 2020

- Easting and Northing coordinates are UTM NAD83 feet
- Elevation is in feet above mean sea level.

The 2011 drill program was completed by Drift Exploration Drilling, based in Val-d'Or, Quebec, Canada with a field office in Winnemucca, Nevada. The 2016 RC drilling contractor was Boart Longyear, based in Salt Lake City, Utah with a field office in Elko, Nevada. The 2019 RC drilling contractors at GBS were DeLong Construction and Drilling, based in Winnemucca, Nevada, and Boart Longyear, from Elko, Nevada; Boart Longyear based in Salt Lake City, Utah completed the 2019 core holes. In 2020, DeLong was again the RC contractor, with Elko-based National EWP also drilling core and RC.

All these contractors are reputable, well-established drilling companies with personnel experienced in drilling and sampling Carlin-style deposits.

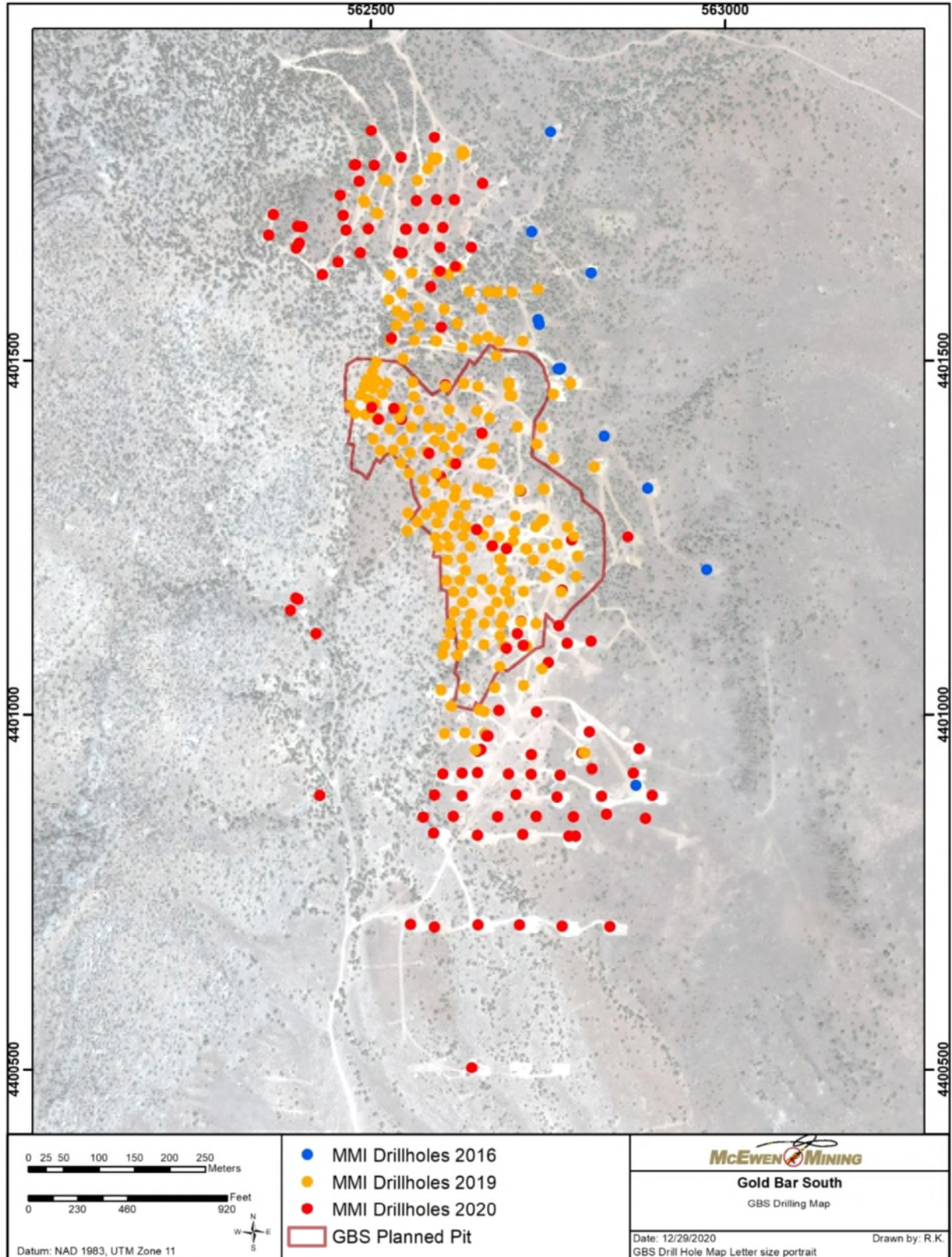


Figure 7-13: GBS Drill hole Location Map (Coordinates are UTM NAD 83 meters)

## **7.8 PROCEDURES**

The procedure for RC drilling, which comprises 87% of the database, consists of impact- and rotation-driven advance with a hammer bit on the end of the string of double-walled pipe. Compressed air and water are injected down the annulus of the pipe to the bit. The cuttings are then carried up the center chamber of the pipe by the air and water stream, through a discharge hose into a cyclone that allows air to escape. The water and sample cuttings then pass through a rotary riffle splitter with two discharge ports. Approximately 3-4 kg of cuttings are directed from the rotary splitter into a cloth sample bag. Using cloth bags allows excess moisture to seep out while retaining solid sample material.

RC drill samples at GBN were collected over continuous 5-foot intervals for the entire drill hole length. Sampling starts at the surface and assay results for the entire length drilled are included in the database.

Sample identification codes for recent GBN drill holes are a concatenation of the drill hole ID and footage interval, e.g. GB77 095-100. Sample ID codes are marked on cloth sample bags with indelible marker and are ready before the interval is drilled. For the 2020 drill program, bar-code tags were implemented and attached to the bags to identify the samples. Sample naming and collection practices for GBS drilling are the same as the GBN system. In addition, at GBS, six trenches excavated in 2020 were channel sampled by McEwen over nominal 10-foot sample lengths with breaks at lithologic, alteration or structural boundaries. Sample labeling and insertion of QC samples was identical to that used for RC drill holes. Each trench sample site was surveyed, providing accurate x-y-z coordinates. These trenches were subsequently treated as drill holes and added to the drill hole database.

Most of the recent GBN and GBS drill holes were surveyed with a downhole north-seeking gyroscopic tool near the total depth to quantify drill hole deviation. Many drill holes without downhole surveys are vertical. Although deviation can occur at any drilled depth, the effect of downhole deviation from the estimated trajectory is minor for short holes compared to the resolution of the block model to which they were applied. Multi-shot magnetic instruments were commonly used to survey drill hole deviation prior to about 2000, but the current industry best practice for quality data is gyroscopic surveying, preferably with a north-seeking gyroscope. International Directional Services (IDS) based in Elko, Nevada completed most of the deviation surveys. In mid-2020 a north-seeking gyroscope was rented from IDS to support the program.

For most legacy GBS drill holes, constant dip angles are assumed in the database because downhole surveys were not available or completed. The artificial straight trajectory is likely to introduce increasing error with increasing depth of the drill holes. However, with shallow mineralization, short drill hole length, and vertical hole orientation, it means the impact of deviation uncertainty in downhole trajectory is minimal compared to the resolution of the block model. The 2016 drilling program included three holes with gyroscopic downhole surveys. Many of the 2019 and 2020 RC and core holes were surveyed with a downhole north-seeking gyroscopic instrument by IDS, or with a rental instrument, near total hole depth including all 2020 dump-area condemnation holes.

After a core or RC hole is completed, it is abandoned per Nevada statutes (NAC 534.4369 through 534.4371) to prevent cross contamination between aquifers, and the required cement seal (neat cement plug from 10 feet below the surface to the surface) placed to prevent contamination by surface access.

After abandonment, drill hole collars were surveyed with a Trimble® GeoXH GPS survey equipment, to an easting / northing precision of 10 cm, and elevation precision of 10 cm after applying correction factors during data processing. Before McEwen established this survey system in 2008 at GBN, drill hole collars were surveyed by an outside consultant to approximately the same precision. Independent surveyors were contracted to survey recent and historic drill hole collar locations at GBS prior to McEwen's acquisition of the property.



## **7.9 INTERPRETATION AND RELEVANT RESULTS**

GBN drill collars for the post-2008 McEwen drilling were collected by in-house surveyors using high-accuracy Trimble® GPS survey equipment. SRK (2015) validated survey locations of 2010, 2011, and 2015 drill hole locations on the ground relative to the digital database.

Drilling, logging, and sampling procedures at GBN were completed to meet or exceed current industry standards, and the available data is internally consistent, suggesting the data set, including historical data, is of high overall quality.

GBS drill collars located prior to and including 2011 were investigated and reported by MDA (2011). Recent McEwen drilling was surveyed using in-house high-accuracy Trimble® GPS survey equipment. Drill collars were validated visually compared to disturbance areas on aerial imagery. In addition, at GBS a high-resolution topographic survey was acquired in 2020 which shows good correlation with elevations in drill hole collar surveys.

The lack of down-hole surveys for many pre-2019 GBS holes has undoubtedly introduced some uncertainty in the absolute location of drill intercepts, but this is within tolerance relative to the size and spacing of model blocks into which the intercepts were estimated.

Drilling, logging, and sampling procedures at GBS were completed to meet or exceed current industry standards, and the available data is internally consistent, suggesting the data set (including historical data) is of high overall quality.

## **8 SAMPLE PREPARATION, ANALYSES AND SECURITY**

Sample preparation for the 2011, 2015 and 2017-2020 drilling programs were completed by ALS Minerals (ALS) at the ALS facility in Elko, Nevada. Sample analysis by fire assay (FA) and sodium cyanide digestion with atomic absorption finish was completed at the ALS lab in Reno, Nevada. Select pulp samples were then forwarded to ALS in Vancouver, B.C. for multi-element ICP-MS analysis (ME-MS41). Sample security was maintained at the Project site until samples were relinquished to the analytical laboratory for preparation and analysis. Documented chain-of-custody is maintained for all samples at the analytical laboratories, until the remaining pulp and coarse reject samples are returned to McEwen's Tonkin Springs facility for storage. Check assays for GBN samples were completed by Bureau Veritas (BV) Labs, in Sparks, Nevada. All of the laboratories mentioned are independent of McEwen. This Technical Report author believes that the sample preparation, analysis, and security procedures are carried out in accordance with best exploration and industry practices.

### **8.1 SAMPLING AND SECURITY MEASURES**

McEwen personnel picked up core from the drill daily and transported the core to its Tonkin Springs warehouse facility. All core was thoroughly washed. Core was then logged to collect geotechnical data including recovery, RQD, fracture frequency and joint condition. Core was then geologically logged. Logged data were input into an excel spreadsheet and uploaded into the company's Datamine Fusion database. Based on geologic logging, sample intervals were determined by the geologist. Sample intervals are nominally 5-foot (1.5 meters) but could range from 1-foot (0.3 meters) up to 7 feet (2.1 meters) based on the geology of the sample interval. Aluminum tags with down hole depth written on them were stapled into the core box to physically denote sample intervals. A cut sheet with all sample intervals listed was also constructed. Certified Reference Materials (CRM) samples were inserted into the cutsheet with a sample number and name of the CRM sample used. Once metal tags were affixed to the core boxes denoting sample intervals, the core was photographed. Core was then sawn in half by McEwen geotechnicians as directed by the cutsheet and confirmed by the aluminum tags stapled in the core box. Cut core samples were placed in cloth bags labeled with the sample identification number and footage as prescribed by the cutsheet, with one-half core returned to the core box for storage and future reference.

RC drill cuttings were collected in sample bags at continuous 1.5-meter (5-foot) intervals from a rotary cyclone splitter located on the drill. A reference subsample of each interval was placed in a chip tray. At the end of a sample run, the sample bag opening was secured and laid on a plastic ground liner to facilitate drying of the sample. Following completion of the drill hole, samples were collected by McEwen geotechnicians. The project geologist completed a cutsheet that denoted the footage and assigned sample number. CRM samples were also inserted into the cutsheet with a sample number and name of the CRM sample used.

Core and RC samples typically were hand delivered by McEwen personnel to the ALS prep facility in Elko, Nevada. All samples delivered were accompanied with complete sample lists, CRM's, and chain of custody forms to track samples by drill hole. Following sample prep in Elko, pulps were shipped to the ALS facility in Reno, Nevada for desired analysis.

### **8.2 SAMPLE PREPARATION FOR ANALYSIS**

Sample preparation was completed at the ALS Elko Laboratory. The procedure codes and descriptions are listed in Table 8-1. The crushing and pulverizing criteria are standard for sediment-hosted gold deposits.

**Table 8-1: Sample Preparation Procedure**

| ALS Code | Description   |
|----------|---|
| LOG-22   | Log samples, received without bar codes                           |
| FTG-01   | Record sample intervals as footage                                |
| WEI-21   | Weigh received sample   |
| LOG-22d  | Log duplicate samples   |
| PUL-31d  | Pulverize duplicate samples                                       |
| CRU-QC   | Crushing Quality Control test                                     |
| PUL-QC   | Pulverizing Quality Control test                                  |
| CRU-31   | Fine crushing - 70% < 2mm   |
| SPL-21d  | Split sample for duplicate coarse reject analysis, select samples |
| SPL-21   | Split crushed sample with riffle splitter, yield 1000g            |
| PUL-31   | Pulverize split to 85% <75 microns                                |
| LOG-24   | Pulp sample login at analytical lab                               |

Source: ALS, 2015.

Samples were crushed until 70% of the sample was finer than a nominal two millimeter in size. A 250- gram sub-sample was taken from the crushed material and pulverized until 85% passed a 200 mesh (75 µm) screen (ALS Method PREP-31).

### 8.3 SAMPLE ANALYSIS

Pulps were then shipped to the ALS facility in Reno, Nevada for analysis. Laboratory methods and detection limits are listed in Table 8-2, with the gold fire assay- atomic absorption spectrometry (FA-AAS) method used for all GBN samples and most GBS samples. A 30-g aliquot of pulverized material (pulp) was split and subjected to FA with AA final analysis for gold (ALS Method Au-AA23). Any gold assays greater than 10 g/t Au (0.292 oz/st Au) were re-analyzed by gravimetric fire assay methods (ALS Method Au-GRA21). All samples that yielded greater than 0.2 ppm fire assay were analyzed for cyanide solubility. Cyanide solubility was determined by using a 30-g aliquot of pulp mixed with dilute cyanide solution and agitated for one hour then analyzed with an AA finish (ALS Method Au-CN13).

The highlighted fields in Table 8-2 describe the FA-AAS method, which is equivalent for both laboratories used for the 2015 and subsequent drill programs. All gold data used in the resource model was reported by ALS, either from FA-AAS finish, or gravimetric analysis for samples greater than 10 g/t (0.292 oz/st) Au. In the following discussion, primary GBN and GBS results from ALS are compared to the re-analysis results of the primary pulp at BV Labs, which completed fire assay, gravimetric, and cyanide leach analysis.

**Table 8-2: Analytical Methods for Gold**

| Laboratory | Method Code | Detection Limits (ppm) |       | Description                           |
|------------|-------------|------------------------|-------|---------------------------------------|
|            |             | Lower                  | Upper |                                       |
| ALS        | Au-AA23     | 0.005                  | 10    | Fire Assay Fusion, AAS Finish         |
| ALS        | Au-ICP21    | 0.001                  | 10    | Fire Assay Fusion, ICP Finish         |
| ALS        | Au-GRA21    | 0.05                   | 5000  | Fire Assay Fusion, Gravimetric Finish |
| ALS        | Au-AA13     | 0.03                   | 50    | Sodium Cyanide Digestion, AAS Finish  |
| BV         | FA430       | 0.005                  | 10    | Fire Assay Fusion, AAS Finish         |
| BV         | FA530-Au    | 0.9                    |       | Fire Assay Fusion, Gravimetric Finish |
| BV         | CN401       | 0.03                   | 50    | Sodium Cyanide Digestion, AAS Finish  |

Source: ALS, BV 2020

## **8.4 QUALITY ASSURANCE/QUALITY CONTROL PROCEDURES**

Analytical Quality Assurance / Quality Control measures helped to assess the reliability of the sample preparation and analysis procedures. McEwen conducted an industry-standard QA/QC program. The QA/QC program consisted of the insertion of blanks and Certified Reference Materials (CRM) into the sample stream and the analysis of duplicate drill-rig and pulp samples. Analytical results of field-duplicate pairs, duplicate pulps from coarse rejects, and duplicate analysis results of pulp samples are discussed in this section. Comparison of results from duplicate pairs would show any bias introduced from sample reduction at each phase of preparation for analysis.

### **8.4.1 Gold Bar North Certified Reference Material Samples**

CRM samples with certified gold values were included in the sample sequence as part of McEwen standard QA/QC protocols. The CRMs used for the 2018-2020 drilling programs were prepared by Mineral Exploration and Environmental Geochemistry (MEG) Laboratories, Washoe City, Nevada, from naturally occurring mineralized rock. Certified mean values and the number of each MEG CRM included in the 2019 and 2020 drilling programs are shown in Table 8-3.

All preparation was done at MEG to create a batch of homogeneous pulp, typically on the order of 500 kg. Mean gold values were certified by analyzing five samples at four or five analytical laboratories accredited in the United States and Canada. The round-robin analysis also included repeat analysis of the same 100 g pulp sample, for a more robust data set.

In late 2020, McEwen began to incorporate CRM samples prepared by CDN Resource Laboratories Ltd., Langley, BC, Canada (CDN). CDN-generated CRMs were sourced from similar Carlin-style deposits as Gold Bar on the Cortez/Battle Mountain trend, Nevada. Reject ore material was dried, crushed, pulverized, and then passed through a 270-mesh screen. The passing material was mixed for five days in a double-cone blender. Splits were sent to 15 commercial laboratories for round robin assaying. Assay laboratories were located in Canada, United States, Ireland, Peru, and Australia. The two CDN CRMs used in 2020 are also presented in Table 8-3.

### **8.4.2 Gold Bar North Blank Material Samples**

Known barren material is included in the sample sequence to test for cross-contamination introduced during sample preparation and analysis. Pulverized silica sand, purchased in 50 g envelopes from MEG Labs (MEG), has been used for blank samples during the recent drilling programs at GBN. The MEG identification is MEG-Blank.14.05. The envelopes are marked by McEwen staff and included in the sample sequence of drill hole pulp samples.

Blank sample results are graphed in Figure 8-1, with lines for method detection limit and ten times the method detection limit, the expected maximum value. All blank samples performed as expected, with only one sample out of 939 samples submitted returned an anomalous value exceeding 10 times detection limit.

A coarse blank was included into the sample sequence designed to evaluate the preparation of sample pulp material for cross sample contamination. Coarse blank material was provided by MEG consisting of high silica rhyolite labelled and MEG-SiPrepBlank.20.99. Results of GBN blank material is presented in Figure 8-1. In total, blank material constitutes 33.36% of all CRM samples.

**Table 8-3: Gold Bar North Certified Reference Material Samples**

| CRM ID                | Au (ppm) | SD     | GBN Count | Combined Total Percent |
|-----------------------|----------|--------|-----------|------------------------|
| MEG-Blank.14.05       | <0.005   |        | 450       | 15.09%                 |
| MEG-SiPrepBlank.20.99 | <0.005   |        | 545       | 18.27%                 |
| MEG-Au.11.13          | 1.806    | 0.081  | 2         | 0.07%                  |
| MEG-Au.12.11          | 1.465    | 0.081  | 151       | 5.06%                  |
| MEG-Au.12.25          | 0.72     | 0.032  | 163       | 5.46%                  |
| MEG-Au.12.32          | 0.616    | 0.017  | 67        | 2.25%                  |
| MEG-Au.13.03          | 1.823    | 0.107  | 378       | 12.67%                 |
| MEG-Au.13.04          | 0.013    | 0.0018 | 42        | 1.41%                  |
| MEG-Au.17.01          | 0.381    | 0.015  | 298       | 9.99%                  |
| MEG-Au.17.02          | 0.511    | 0.03   | 11        | 0.37%                  |
| MEG-Au.17.06          | 0.098    | 0.08   | 84        | 2.82%                  |
| MEG-Au.17.07          | 0.188    | 0.011  | 209       | 7.01%                  |
| MEG-Au.17.09          | 0.767    | 0.038  | 100       | 3.35%                  |
| MEG-Au.17.22          | 0.715    | 0.021  | 365       | 12.24%                 |
| MEG-Au.19.08          | 0.198    | 0.006  | 79        | 2.65%                  |
| CDN GS-2T             | 1.75     | 0.1    | 20        | 0.67%                  |
| CDN-P1A               | 0.143    | 0.008  | 19        | 0.64%                  |

Source: MEG, CDN 2020

## Gold Bar North Blank Material (coarse blank and pulp blank)

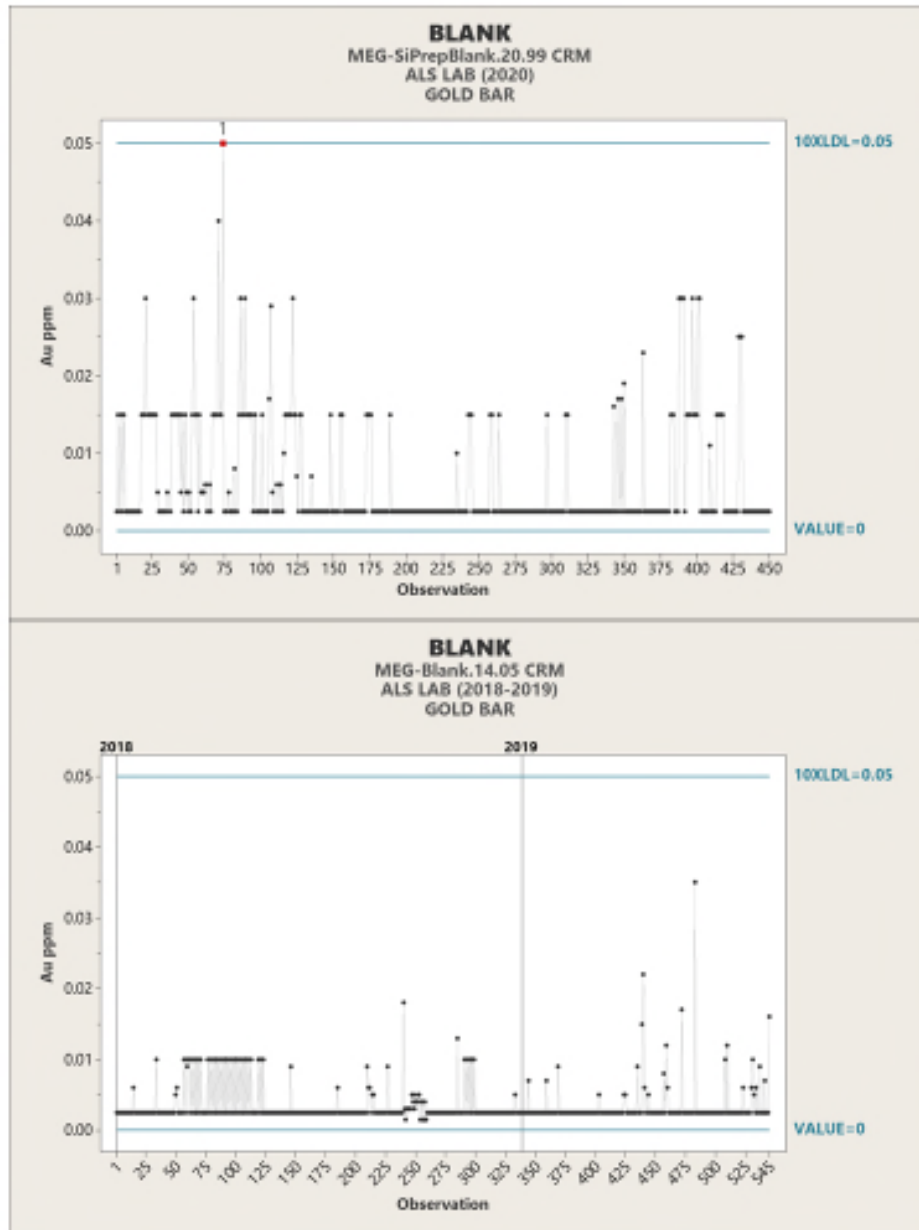


Figure 8-1: Results of Coarse Blank and Pulp Blank Samples at GBN (McEwen, 2020)

### 8.4.3 Gold Bar North CRM Material Samples

Fifteen individual CRMs were employed at GBN during 2019 and 2020. The results of all CRMs employed are presented in Figure 8-2 and Figure 8-3.

## Gold Bar North CRMs

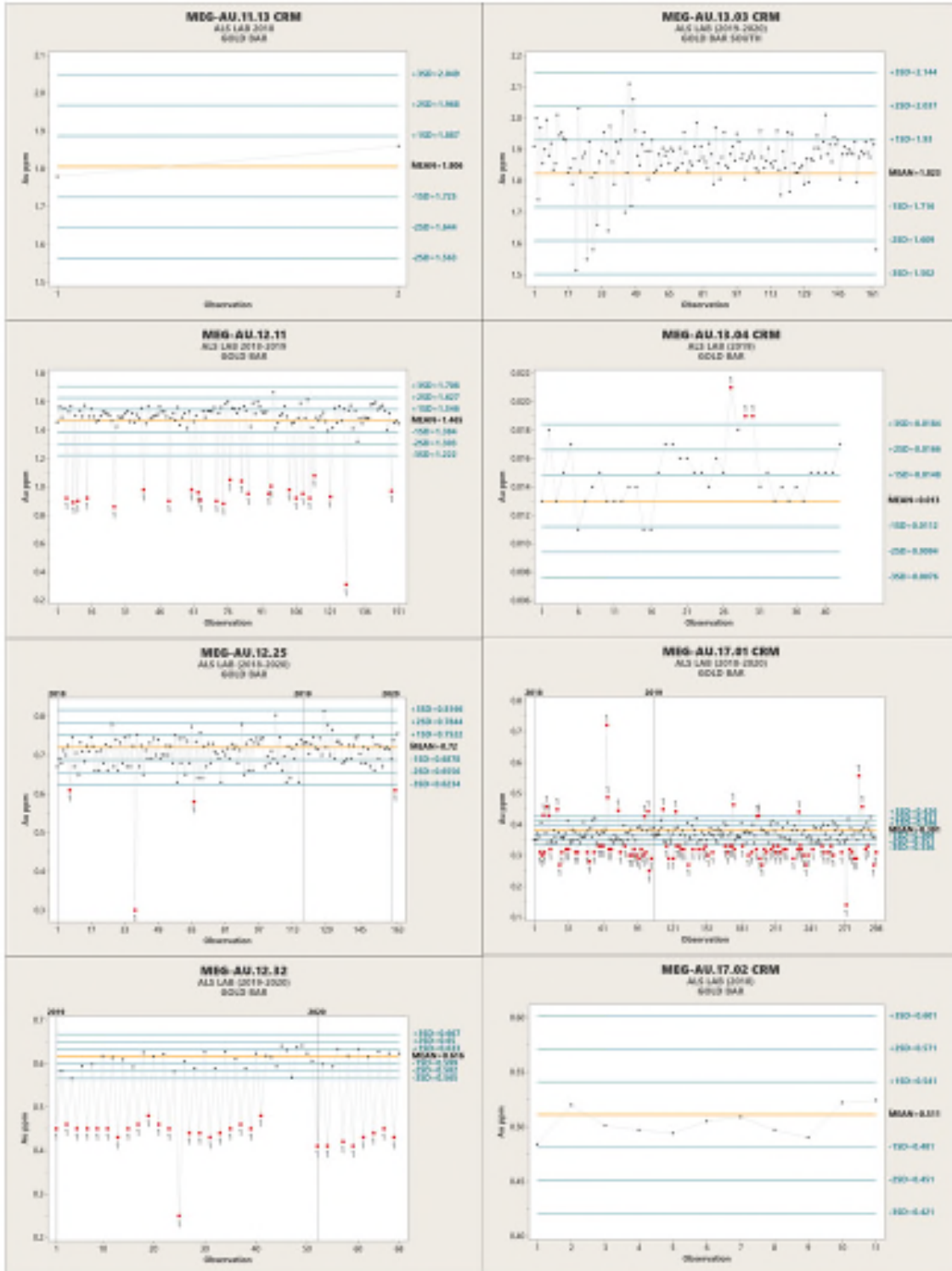


Figure 8-2: Graphical Representation of CRM Results in Chronological Order Mean Au Value is Represented by the Orange Line with 1, 2, and 3 Standard Deviation Lines Presented in Blue (McEwen, 2020)

## Gold Bar North CRMs

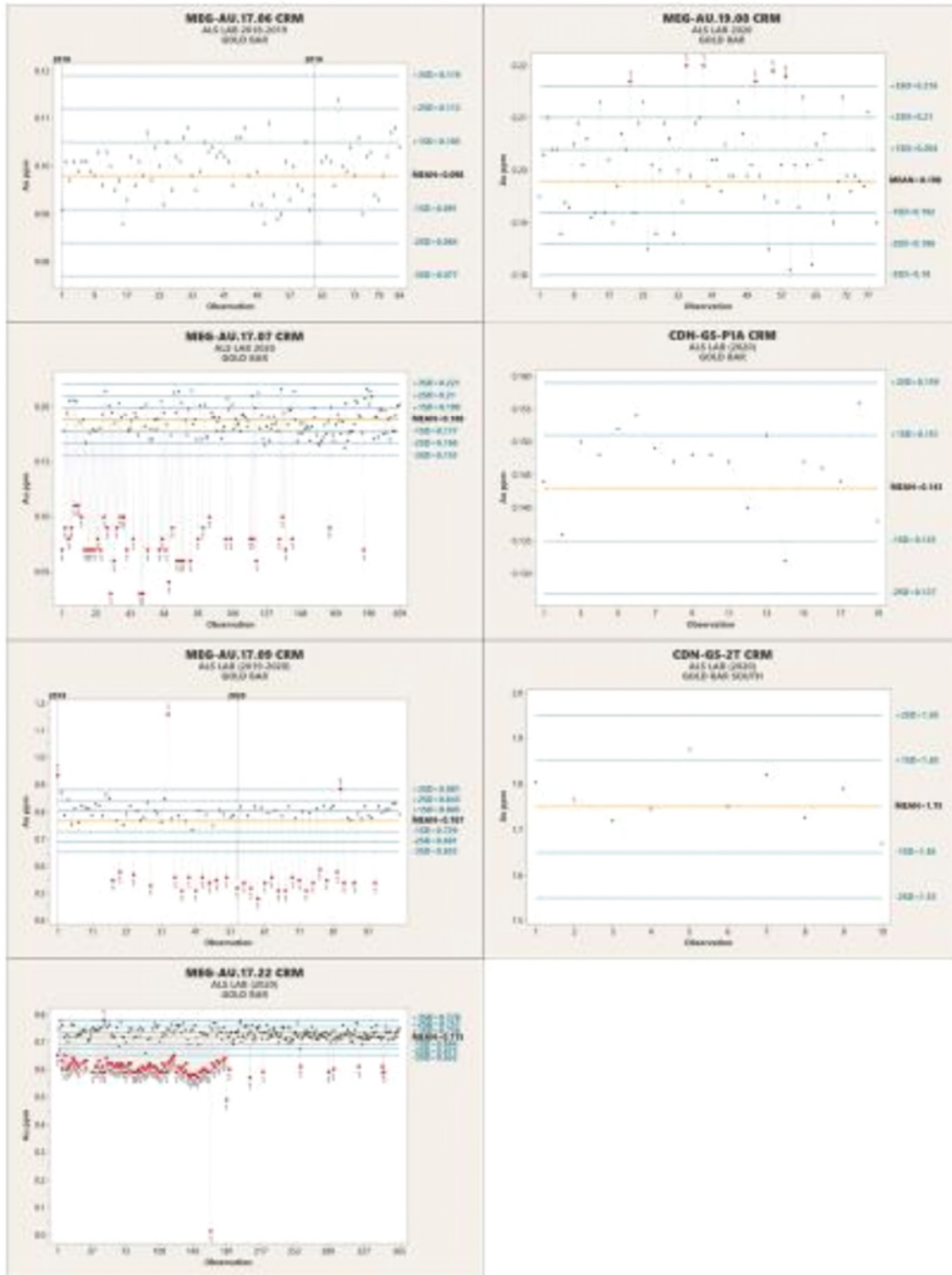


Figure 8-3: Graphical Representation of CRM Results in Chronological Order. Mean Au Value is Represented by the Orange Line with 1, 2, and 3 Standard Deviation Lines Presented in Blue (McEwen, 2020).



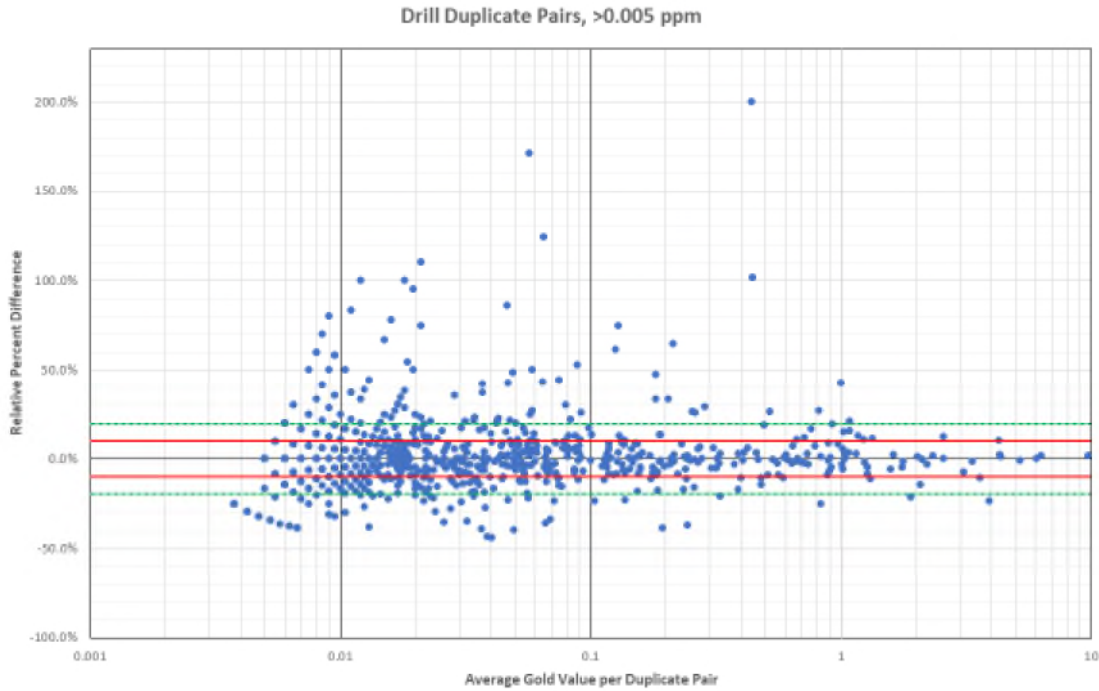
Most of CRMs used in 2019 and 2020 yielded results consistent with expectations. There were five MEG CRMs, however, that had a higher-than-expected failure rate. Following a detailed evaluation, all the CRMs with higher-than-expected failure rates did not indicate a lab bias or sampling bias and appeared to be isolated to the individual CRM. Two CRMs, MEG-Au.12.32 and MEG-Au.17.22 appeared to show more of a pattern of potential bias. MEG-Au.12.32 samples did appear to show potential instrument drift and MEG-Au.17.22 showed a high failure rate in samples submitted in 2019, but not in 2020. Other CRMs that were submitted at the same time did not exhibit the same patterns, therefore it is believed that the issue was related to the CRM itself. Per standing protocol, when a CRM failed QA/QC review, several drill samples that surround the failed CRM were re-analyzed for verification. There were no instances of the original assay being materially different than the rerun assay due to a failed CRM. Once a CRM was identified as being unreliable, the use of that CRM was discontinued. Due to several unreliable MEG CRMs, McEwen began to transition to CDN Laboratories CRM. Although relatively limited in population, the CDN CRMs appear to be performing as expected with no samples exceeding 3-sigma to-date.

#### **8.4.4 Gold Bar North Duplicates**

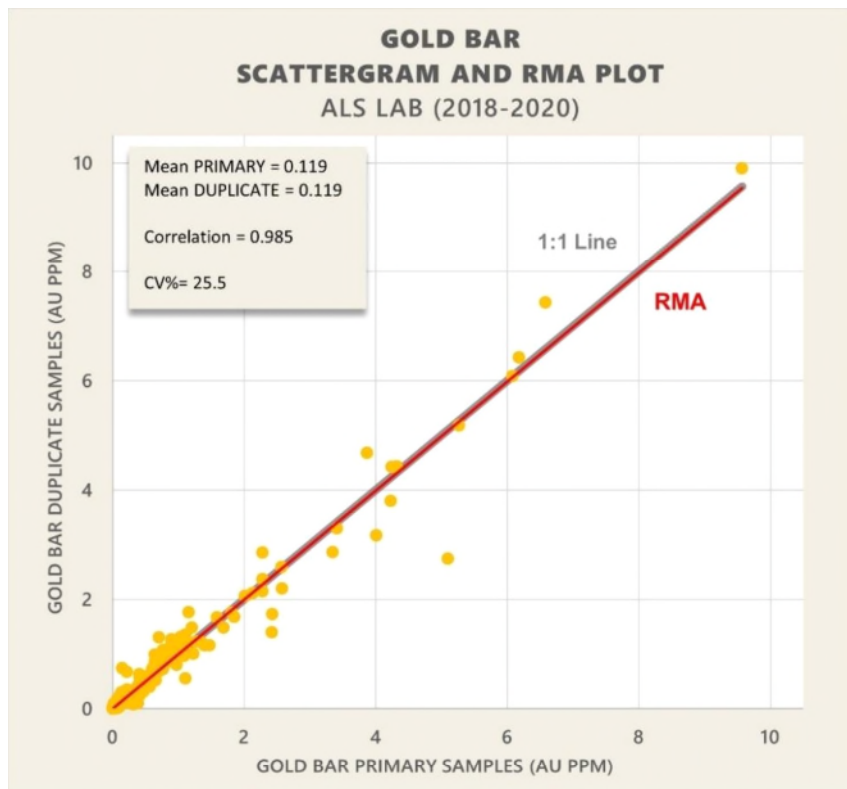
Duplicate sample programs typically consisted of drill rig duplicates and third-party assay checks. For 2018 thru 2020 programs, drill rig duplicates were performed at Gold Bar. Drill rig duplicate samples were used to assess assay repeatability before sample preparation. Sample prep procedures for the 2018, 2019, and 2020 programs included duplicate pairs of samples collected at every twentieth interval at the drill. There were 1,438 coarse reject sample duplicate pairs in the 2018 thru 2020 drilling programs. All primary and duplicate assays were performed by ALS in Sparks, Nevada. Figure 8-4 shows the relative percent difference of fire assay results for the 911 coarse reject sample pairs with gold values greater than the method's detection limit of 0.005 ppm. The target variation for these samples is +/- 20% of the original sample value, shown with dashed green lines.

Variability in the coarse reject composition is evident for low grade samples, due to greater uncertainty for values up to 10 times the method's detection limit, about 0.050 ppm. A systematic bias in coarse reject sample pairs is not evident. For sample pairs of economic gold grades, the variability of the coarse rejects is low. This indicates adequate crushing, homogenization, and splitting in advance of sample pulverization.

Third party lab check samples were sent to BV in Sparks, Nevada. Third party check samples were completed in 2018 and 2019 only with 576 pulp pairs plotted on a scatterplot (Figure 8-5) and evaluated for bias. The mean for both the primary and duplicate samples are the same at 0.119 with a correlation coefficient of 0.985, suggesting there is no internal lab bias of the primary lab.



**Figure 8-4: Coarse Reject Duplicate Sample Pairs Relative Percent Difference vs. Average (McEwen, 2020)**



**Figure 8-5: Scatter Plot of RC Rig Primary vs. Duplicate Sample Gold Assay Pairs (McEwen, 2020)**

#### **8.4.5 Gold Bar South Certified Reference Material Samples**

CRM samples with certified gold values were included in the sample sequence as part of McEwen standard QA/QC protocols. The CRMs used for the 2018-2020 drilling programs were prepared by Mineral Exploration and Environmental Geochemistry (MEG) Laboratories, Washoe City, Nevada, from naturally occurring mineralized rock. Certified mean values and the number of each MEG CRM included in the 2019 and 2020 drilling programs are shown in Table 8-4.

All preparation was done at MEG to create a batch of homogeneous pulp, typically on the order of 500 kg. Mean gold values were certified by analyzing five samples at four or five analytical laboratories accredited in the United States and Canada. The round-robin analysis also included repeat analysis of the same 100 g pulp sample, for a more robust data set.

In late 2020, MII began to incorporate CRM samples prepared by CDN Resource Laboratories Ltd., Langley, BC, Canada. CDN-generated CRMs were sourced from similar Carlin-style deposits as Gold Bar on the Cortez/Battle Mountain trend, Nevada. Reject ore material was dried, crushed, pulverized, and then passed through a 270-mesh screen. The passing material was mixed for five days in a double-cone blender. Splits were sent to 15 commercial laboratories for round robin assaying. Assay laboratories were located in Canada, United States, Ireland, Peru, and Australia. The two CDN CRMs used in 2020 are also presented in Table 8-4.

#### **8.4.6 Gold Bar South Blank Material Samples**

Known barren material was included in the sample sequence to test for cross-contamination introduced during sample preparation and analysis. Pulverized silica sand, purchased in 50 g envelopes from MEG Labs, has been used for blank samples during the recent drilling programs at GBN. The MEG identification is MEG-Blank.14.05. The envelopes were marked by McEwen staff and included in the sample sequence of drill hole pulp samples.

Blank sample results are graphed in Figure 8-6, with lines for method detection limit and ten times the method detection limit, the expected maximum value. All blank samples performed as expected, with only one sample out of 939 samples submitted returned an anomalous value exceeding 10 times detection limit.

A coarse blank was included into the sample sequence designed to evaluate the preparation of sample pulp material for cross sample contamination. Coarse blank material was provided by MEG consisting certified coarse crushed concrete cinder blocks labelled MEG-CaBlank.17.13 and MEG-SiPrepBlank.20.99. Results of GBN blank material is presented in Figure 8-6. In total, blank material constitutes 36.82% of all CRM samples.

**Table 8-4: Gold Bar South Certified Reference Material Samples**

| CRM ID                | Au (ppm) | SD     | GBS Count | Combined Total Percent |
|-----------------------|----------|--------|-----------|------------------------|
| MEG-CaBlank.17.13     | <0.005   |        | 176       | 18.57%                 |
| MEG-SiPrepBlank.20.99 | <0.005   |        | 173       | 18.25%                 |
| MEG-Au.12.11          | 1.465    | 0.081  | 8         | 0.84%                  |
| MEG-Au.12.25          | 0.72     | 0.032  | 13        | 1.37%                  |
| MEG-Au.12.32          | 0.616    | 0.017  | 146       | 15.40%                 |
| MEG-Au.13.03          | 1.823    | 0.107  | 163       | 17.19%                 |
| MEG-Au.13.04          | 0.013    | 0.0018 | 6         | 0.63%                  |
| MEG-Au.17.01          | 0.381    | 0.015  | 78        | 8.23%                  |
| MEG-Au.17.06          | 0.098    | 0.08   | 29        | 3.06%                  |
| MEG-Au.17.07          | 0.188    | 0.011  | 1         | 0.11%                  |
| MEG-Au.17.09          | 0.767    | 0.038  | 29        | 3.06%                  |
| MEG-Au.17.22          | 0.715    | 0.021  | 29        | 3.06%                  |
| MEG-Au.19.08          | 0.198    | 0.006  | 77        | 8.12%                  |
| CDN GS-2T             | 1.75     | 0.1    | 10        | 1.05%                  |
| CDN-P1A               | 0.143    | 0.008  | 10        | 1.05%                  |

## Gold Bar South Blank Material (coarse blank and pulp blank)

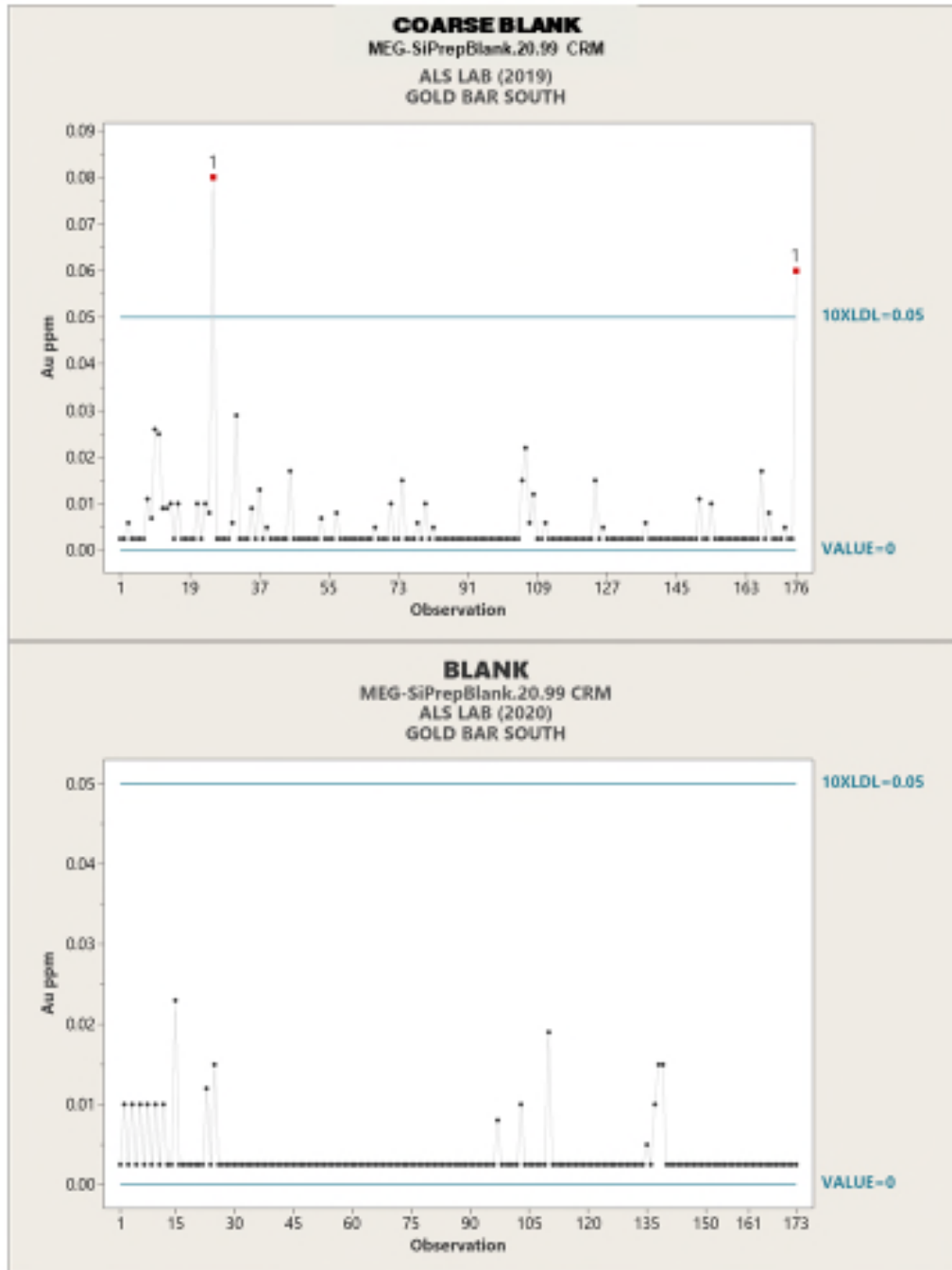


Figure 8-6: Results of Coarse Blank and Pulp Blank Samples at GBS (McEwen, 2020)

#### **8.4.7 Gold Bar South CRM Material Samples**

Thirteen individual CRMs were employed at GBS during 2019 and 2020. The results of all CRMs employed are presented in Figure 8-7 and Figure 8-8. Two CRMs obtained from MEG had a relatively high failure rate; MEG-Au17.01 and MEG-Au.12.32. When a CRM had a failure, several samples on either side of the CRM were re-assayed, including the CRM that failed. In all cases, the re-assay of samples did not show a significant deviation from the original assay and the CRM re-assay passed suggesting an issue with the CRM. Once a CRM was determined to have a high failure rate, that CRM was retired. In late 2020, CRMs from a different source (CDN) started to be employed. The percentage of CDN CRMs employed was relatively low at 2.2%, but they performed as expected. Graphs of the two CDN CRMs employed are presented in Figure 8-8.

## Gold Bar South CRMs



Figure 8-7: Graphical Representation of CRM Results in Chronological Order. Mean Au Value is Represented by the Orange Line with 1, 2, and 3 Sigma Lines Presented in Blue (McEwen, 2020)

## Gold Bar South CRMs

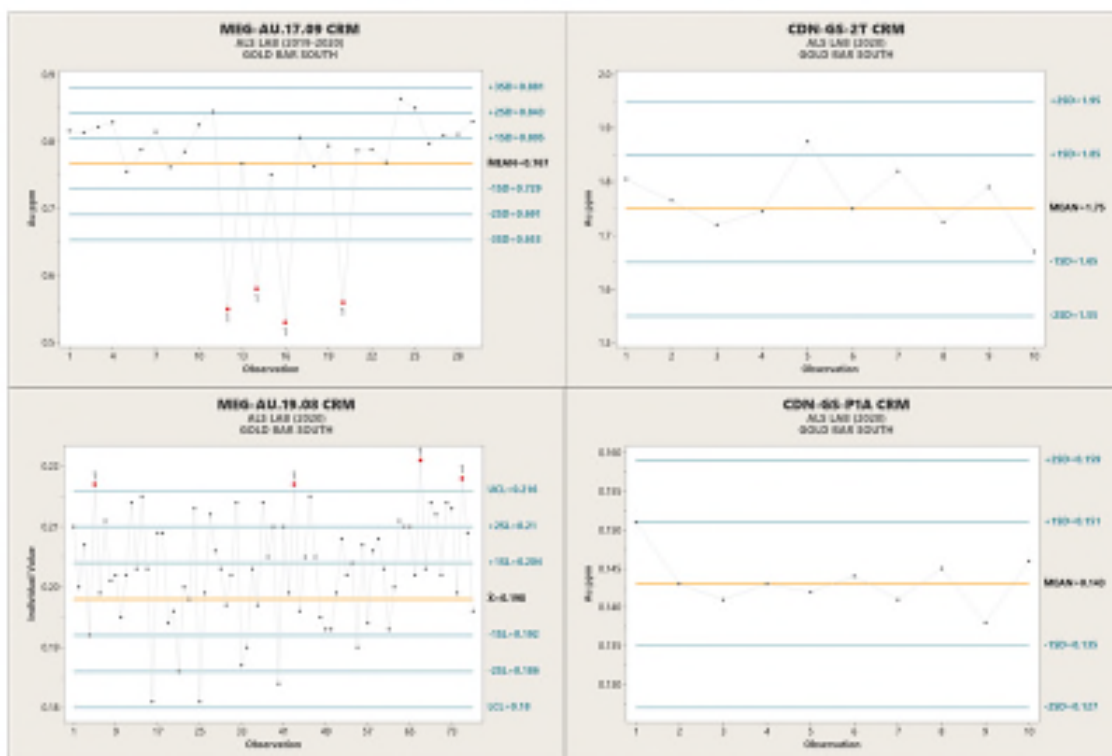


Figure 8-8: Graphical Representation of CRM Results in Chronological Order. Mean Au Value is Represented by the Orange Line with 1, 2, and 3 Sigma Lines Presented in Blue (McEwen, 2020).

### 8.4.8 Gold Bar South Duplicates

Duplicate sample programs typically consisted of drill rig duplicates and third-party assay checks. For 2018 thru 2020 programs, only drill rig duplicates were performed at Gold Bar. Drill rig duplicate samples were used to assess assay repeatability before sample preparation. Sample prep procedures for the 2018, 2019, and 2020 programs included duplicate pairs of samples collected at every twentieth interval at the drill. There were 595 coarse reject duplicate sample pairs in the 2018 thru 2020 drilling programs. All primary and duplicate assays were performed by ALS in Sparks, Nevada. Figure 8-9 shows the relative percent difference of fire assay results for the 434 coarse reject sample pairs with gold values greater than the method's detection limit of 0.005 ppm. The target variation for these samples was +/- 20% of the original sample value, shown with dashed green lines.

Variability in the coarse reject composition was evident for low grade samples, due to greater uncertainty for values up to 10 times the method's detection limit, about 0.050 ppm. A systematic bias in coarse reject sample pairs was not evident. For sample pairs of economic gold grades, the variability of the coarse rejects was low. This indicated adequate crushing, homogenization, and splitting in advance of sample pulverization.

Third party lab check samples were sent to BV in Sparks, Nevada. Third party check samples were completed in 2018 and 2019 only with 369 pulp pairs plotted on a scatterplot (Figure 8-10) and evaluated for bias. The mean for the primary lab is 0.6899 ppm and the third-party lab mean is 0.7055 ppm with a correlation coefficient of 0.998, suggesting there is no internal lab bias of the primary lab.



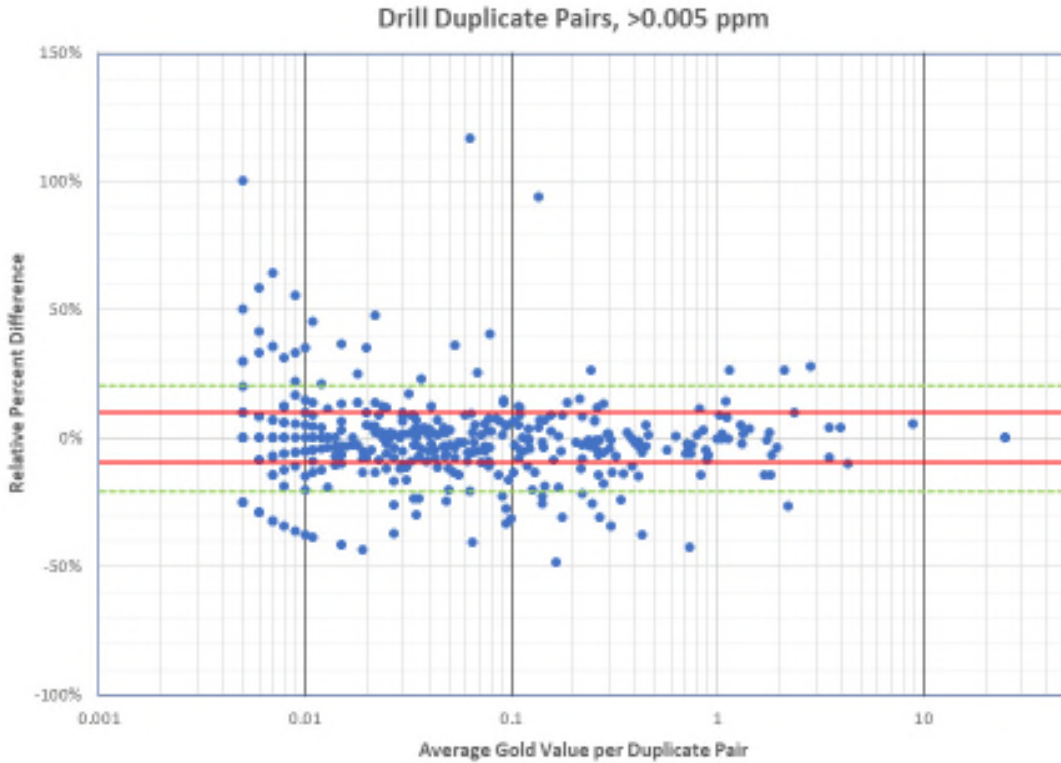


Figure 8-9: 2011 Coarse Reject Duplicate Sample Pairs Relative Percent Difference vs. Average (McEwen, 2020)

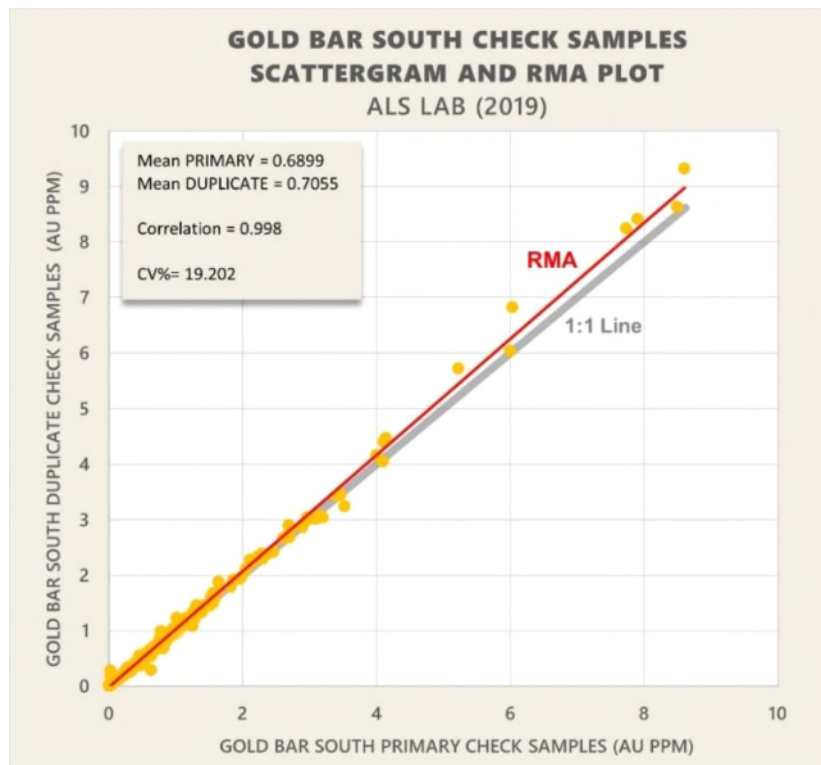


Figure 8-10: Scatter Plot of RC Rig Primary vs. Duplicate Sample Gold Assay Pairs (McEwen, 2020)

#### **8.4.9 Actions – Gold Bar North and Gold Bar South**

The assay Quality Assurance / Quality Control program that McEwen applied to resource drilling met current industry standards. The same QA/QC methods were applied to both Gold Bar North and Gold Bar South. Certified assay results were reviewed upon receipt by McEwen staff, and only a few individuals had permissions to add new data to the main database. Drill sample results were compared to lithology and mineralogy logs to validate assay data before importing it to the database. QA/QC sample results were queried after batches of analytical data were incorporated into the database, as a measure to preserve the integrity of the data as reported by the lab.

To identify “out-of-tolerance” sample intervals, the database was queried to identify the CRM sample values with significant discrepancies from their respective mean values. Results that fell outside of +/- three standard deviations from the certified mean value were considered out of tolerance. A reanalysis was done of an interval of samples adjacent to any CRM assays where out of tolerance occurred whether or not samples were mineralized.

#### **8.4.10 Recommendations**

Insertion of CRMs is a critical part of any QA/QC program and evaluates the sample preparation and assay procedures at a particular lab. In addition, duplicate samples are also a critical part of the QA/QC program. McEwen collected an adequate amount of drill rig duplicates and submitted an adequate number of samples to a third-party lab in 2018 and 2019 but have not submitted sample pulp duplicates to a third-party lab for the 2020 samples. It is recommended that three to five percent of duplicate sample pulps be submitted to a third-party lab as part of the standard QA/QC program. This will check for any systemic bias in the primary lab. McEwen is currently taking steps to rectify this gap in the QA/QC protocols for samples collected in 2020.

Until late 2020, McEwen exclusively used CRMs supplied by MEG. Several CRMs have demonstrated unreliable results, which hampered assay turnaround, especially since all failed CRMs and adjacent samples were rerun regardless of levels of mineralization. In all cases between 2018 and 2020, a failed CRM causing a rerun of samples, the original sample result was not materially changed, and the rerun CRM returned results within acceptable tolerances. It is recommended that CRMs with a high failure rate be discontinued and consideration be given to locating and employing CRMs provided by another supplier. In late 2020, McEwen began to incorporate CRMs supplied by CDN with acceptable results to date. However, there are not enough analyses of CDN CRMs to adequately evaluate their reliability.

McEwen employed up to 15 different CRMs, in addition to two coarse blanks and one silica sand blank between 2018 and 2020. It is suggested that the number of CRMs and blanks be more limited to three or four reliable CRMs, one coarse blank, and silica pulp blank.

#### **8.4.11 Results**

Some key points for improvement in the QA/QC protocol for drill hole samples have been identified. Future drilling programs would benefit from regular insertion of a limited number of high-quality CRMs and coarse blank material. Although the insertion rate and drill rig duplicate sampling are adequate, duplicate pulps to a third-party lab for samples collected in 2020 needs to be implemented. These measures would provide assay results that measure laboratory quality better and would yield more defensible data to include in future resource models. However, current and recent sample handling procedures meet or exceed industry standards, and the recent drill hole dataset is of high quality, suitable for resource modeling.

#### **8.5 OPINION ON ADEQUACY**

The sample handling, security, and preparation procedures used are all appropriate for the style of mineralization at Gold Bar, and they conform to the current exploration and industry best practices. McEwen has applied a QA/QC

**GOLD BAR PROJECT**  
**S-K 1300 TECHNICAL REPORT SUMMARY**

---

sampling program that meets current industry best practices to validate fire assay gold results. Overall, quality control on analytical procedures and assay results is good, and there is sufficient data to verify the quality of sample preparation and analysis.

## **9 DATA VERIFICATION**

The Resource Geologist (QP) regularly visited the Gold Bar site during 2020 to verify drilling and sampling procedures at the drill rigs and sample security before the samples were transferred to ALS. Assay data from this drilling program corroborate the existing database and were compared to geological logs to verify the locations of mineralized intervals relative to material type. The QP also compared a subset of the reported gold values on assay certificates with the values in the electronic database exports used for resource estimation.

### **9.1 PROCEDURES**

The QP verified drill hole locations and sampling procedures in the field, during the 2020 drilling program. Planned and as-built drill hole locations were reviewed by the QP and McEwen exploration staff throughout the drilling program, and no discrepancies were noted. Geological logging was also verified in the field and in 3D by the QP. Logging methodology was found to be standardized across the geology team for the 2020 drilling season. New geologic models were created for Gold Bar in 2020. The new models relied heavily on drilling and logging results from 2017-2020. Historic logged data was also applied to the modeling but was not considered as reliable. The new geologic models corroborate well with analytical results.

McEwen implemented a full dataset validation for Pick, Gold Bar South, Ridge and Cabin in 2020 that will be completed in 2021. The validation for Gold Bar is being conducted by McEwen database and GIS staff from Canada, Mexico, and Argentina under the supervision of the Corporate database manager. Collar locations in the electronic database are compared against original field location documentation from surveys and logging sheets and historic maps relevant to the time and period drilling was executed. Coordinate conversions used to standardize the dataset location are being reviewed and tested. Downhole survey data is compared against drill logs and downhole survey reports. Assay data is compared against original laboratory assay certificates and handwritten entries on the drill logs when certificates are not available. The drill holes were also reviewed by the QP in 2020 in 3D against the new geologic models for Pick, Ridge and Gold Bar South to identify unsupported results. The QP also reviewed Gold Bar South drill hole locations against aerial photography and a 2-meter DTM created in August, 2020. Collar coordinate values that did not fit were flagged by the QP for further review or rejected for resource modeling until review can be finalized.

As part of the validation, the QP reviewed QA/QC results for all drilling used for the Pick, Ridge and Gold Bar South resource estimates. Drilling was completed between 1981 and 2020 under 11 different company names to varying degrees of quality assurance and quality control methodology. The QP has determined that while many of the historic drill holes do not meet the current QA/QC protocols, 3<sup>rd</sup> party analyses were completed over time to validate a portion of the historic drill programs. The remaining unvalidated data used for resource estimation does not show any unexplained deviation compared to surrounding drill hole results when the geologic model is applied. Approximately, 10% of the assays exported from the electronic database for Pick and Gold Bar South were validated against laboratory certificates. Validation was based on random selection of drill holes and all assays for the selected drill holes were reviewed. Discrepancies were noted and reviewed by the database manager. A new dataset was exported and additional drill holes were selected for review.

Downhole survey deviation was reviewed for Pick and Gold Bar South drilling to determine how drill holes without downhole surveys should be used for estimation. It was determined, using existing downhole survey records, that drill holes < 700 feet in length deviate <20 feet on average. This is considered acceptable for modeling of Gold Bar resources by the QP.

McEwen completed three twinned diamond drill holes to confirm results from previous RC drill programs in Pick. Results showed that the assays compared well to the historic RC drill holes.

Decay analysis and rod change interval studies were completed for Pick and Gold Bar South. Where minor issues were found, the drilling was compared against the geologic model. Discrepancies in both analyses were explained by the presence of faulting.

Analytical data are reported in metric units, parts per million (ppm). The analytical values are imported directly to the resource estimation database. The precision of the converted values is limited by the reported values, to thousandths of parts per millions. The final resource estimate is then converted to U.S units (oz/t) using the conversion factor one troy ounce per short ton equals 34.286 g per metric tonne, which is equivalent to ppm.

## **9.2 LIMITATIONS**

Data verification for the Ridge deposit is planned for 2021 and was not completed prior to modeling. Metallurgical test sampling and analyses were not validated in 2020. Data used for the Cabin resource was not validated by the QP or MTS prior to use in the resource estimate. Although geological data is mostly qualitative, it is applied to the resource model. Verification of geological observations is limited to the opinions of McEwen geologists.

## **9.3 OPINION ON DATA ADEQUACY**

Investigations of all aspects of database quality indicate that the data sets used for resource estimation are accurate, and the quality of data is suitable to apply to resource estimation. Although validation of the historic Ridge dataset collected prior to 2017 was not possible, visually the data is well supported by drilling completed between 2017 and 2020. A number of drill holes completed prior to 1991 at GBS were identified as air rotary and while the assays were used for interpolation, the drill holes were not used for classification. The interpolated results utilizing the air rotary samples are outside of the 2020 economic resource pit shells used for reporting.

It is the opinion of the QP that the data available for estimation of geometallurgy is insufficient in extent for Pick and Ridge. Drilling should be completed along with re-analysis of available pulps from previous drill campaigns to fill gaps in the datasets.

## **10 MINERAL PROCESSING AND METALLURGICAL TESTING**

### **10.1 INTRODUCTION**

This section provides an update to the Gold Bar metallurgical ore characterization and performance, and a revision to the process design criteria. As presented in the previous FS published in 2018, the Gold Bar deposit has been subdivided into Gold Bar North and Gold Bar South. This report documents the history of the substantial ore characterization test work including:

- Mineralogy and metallurgical ore types
- The representativeness of the ore samples to the deposit
- Metallurgical ore characterization
- Metal recovery and recovery rate projections
- The basis of the process design criteria

This work is supplemented here with analysis of actual heap leach pad performance of material from Gold Bar North and additional laboratory testing and ore characterization of Gold Bar South.

#### **10.1.1 Gold Bar North**

Gold Bar North consists of three ore deposits: 1) Pick (East and West); 2) Ridge and 3) Cabin. The mineralization is similar for all three deposits and occurs as a sediment-hosted gold deposit. Most of the mineralization is hosted in carbonate-rich sedimentary rocks of the Devonian McColley Canyon Formation and is characterized by micron-sized gold and distinct hydrothermal alteration characteristics.

Most of the metallurgical samples supporting Gold Bar North recovery development were collected in 2010-2011 and reported in the Gold Bar PFS in October 2012 (SRK, 2012). There was additional drilling and metallurgical testing undertaken in the interim between 2012 and 2017. Metallurgical characterization for Gold Bar North presented in the 2018 FS was a combination of the results from:

- 2012 PFS (previously reported [SRK, 2012])
- 2014 bulk column test work
- 2015 bottle roll test on RC drill samples
- 2017 column test work

Recovery projections in the 2018 FS are related to the process plant design, which includes crushing to 100% minus 6-inch, and agglomeration of the minus 3-inch fraction, with the leach pad being loaded after recombining the fractions. Actual leaching at Gold Bar North began in December of 2018. Recovery projections in this report have been updated based on operational differences resulting from an increased percentage of run-of-mine (ROM) ores and elevated clay content in the placed ore, negatively impacting the leaching hydrodynamics.

#### **10.1.2 Gold Bar South**

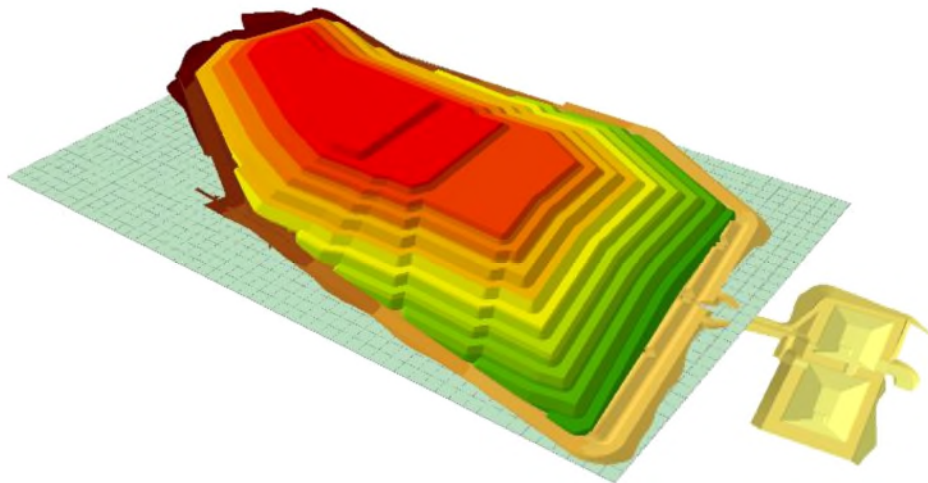
The Gold Bar South deposit's metallurgical characterization has been preliminarily developed and is limited to bottle roll test results completed between 2008 and 2011, column testing, and cyanide digestion gold assays from several drilling programs throughout the history of the Project. Column testing of material from a 2019 drilling campaign has recently been completed. Available results indicate that Gold Bar South ore is oxidized and amenable to cyanidation. About 75% of the Gold Bar South resource is hosted in the Webb Formation, and the remainder is hosted in the underlying Devils Gate Formation.

## **10.2 GOLD BAR NORTH – UPDATED PRECIOUS METAL RECOVERY AND RECOVERY RATE ANALYSIS**

The ore mineralogy of the Gold Bar North deposits consists of an intermixing of oxidized and un-oxidized refractory ores with variable leach recovery. An ultimate extraction of 82% for Gold Bar North was advanced in the 2018 FS and was intended to provide a conservative estimate, downgraded from values observed in test work, to account for typical inefficiencies encountered in full-scale operation including variation in crusher settings, process upsets, poor agglomeration or damaged agglomerates, deficient stacking practices, and poor irrigation practices.

Initiation of mining activities began December 5, 2018 with the first loading of ore onto the heap leach pad. Since then, approximately 6.494 Mtons of ore have been placed with over 100,000 troy ounces produced through December 2021. Analysis of the operational data offers the best opportunity to assess the actual leach extraction and extraction kinetics from placed material. In February 2020, Forte Dynamics, Inc. (Forte) developed a fully dynamic discretized three-dimensional heap leach model used to forecast production from the Gold Bar leach facility. Comparison of the model predictions with actual operational data over time allows the full-scale extraction and leaching rates to be assessed.

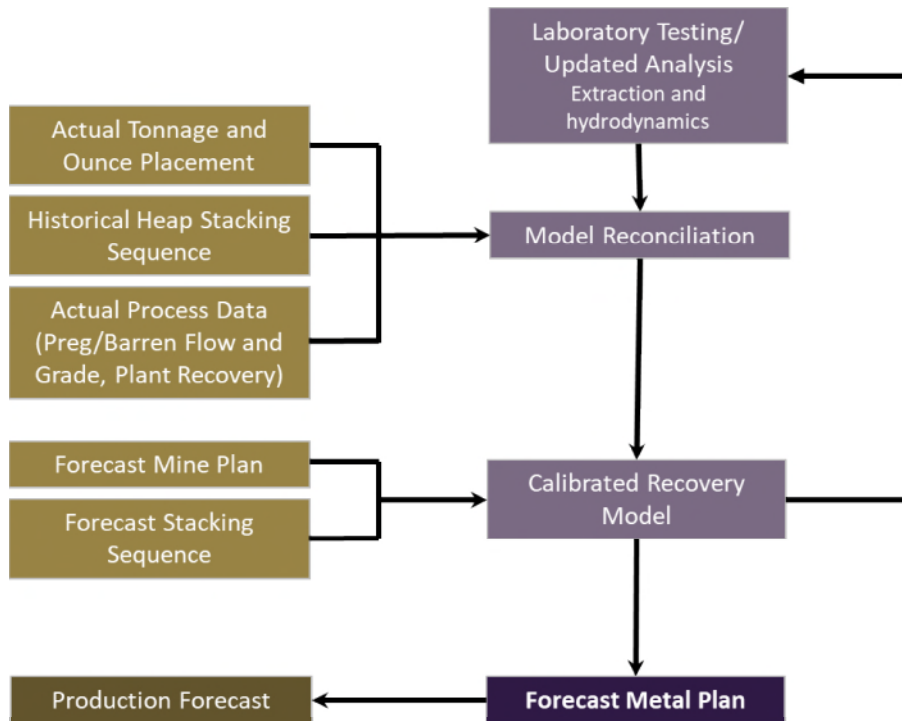
Figure 10-1 shows the modeled stacking superimposed on the underlying grid network used for discretization in the X and Y directions. The lift height is used for discretization in the Z direction yielding 18,876 individual cells.



**Figure 10-1: Heap Leach Pad and Discretization**

### **10.2.1 Heap Leach Pad Model Hydrodynamics and Extraction Calibration**

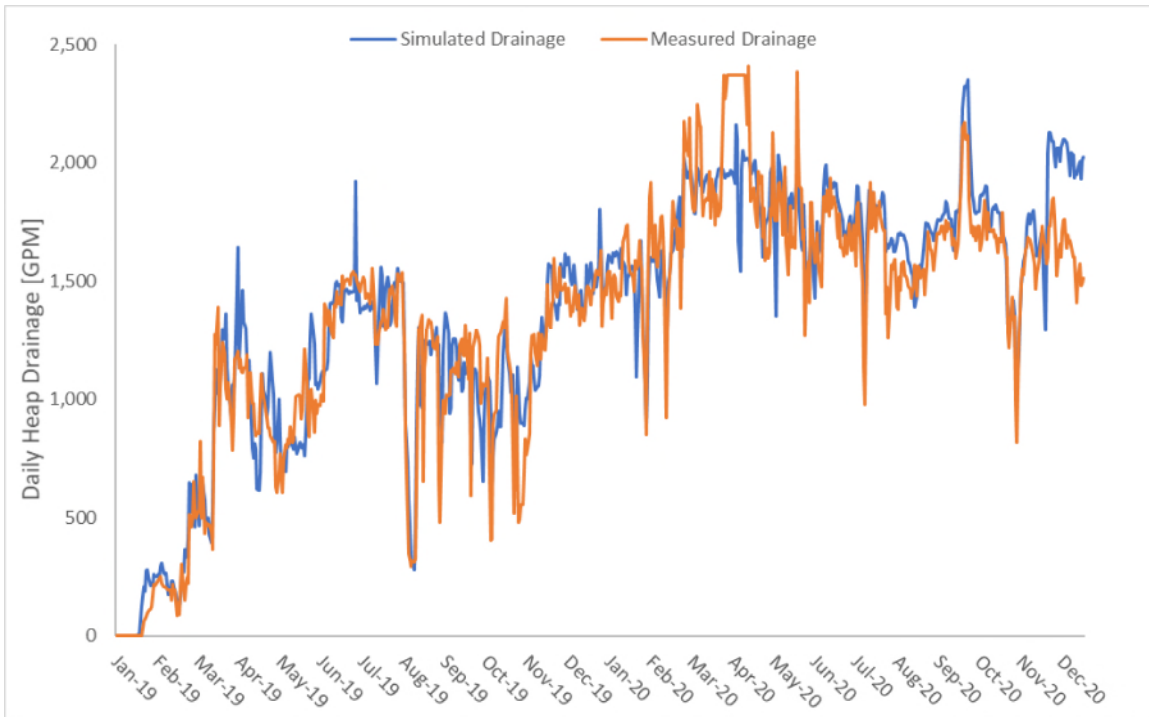
The 2018 FS considered production resulting entirely from crushed and agglomerated ore. As of December 2021, the total ore placement on the leach facility was approximately 6.494 Mtons with 38% of those tons placed as ROM. Forte's dynamic leaching model is used to investigate production from the leach facility and determine the extraction realized for the crushed and ROM fractions. Detailed production records are used to track how material is distributed to the individual cells within the model framework. Leaching is then simulated through time according to the actual leaching program recorded, and a production schedule is generated by considering the actual fundamental leaching kinetics and hydrodynamic transport occurring within the leach pad. Test work results are used as the basis to describe the ore properties, but these values are updated following calibration of the model to better simulate full-scale operations. Figure 10-2 shows the flow of information used to calibrate the leaching model and generate the production schedule.



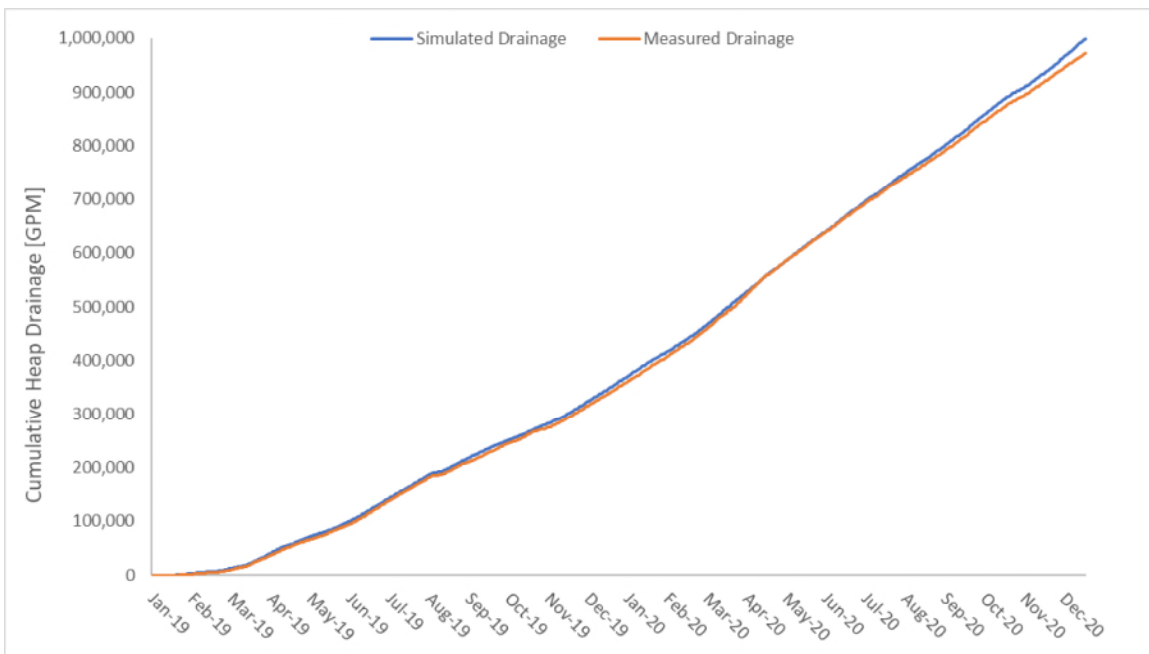
**Figure 10-2: Model Information and Process Flow Diagram (Forte, 2020)**

Transport of solutions within the leach model is simulated utilizing the Brooks-Corey equation for relative permeability. The model calibration for solution transport is assessed by comparing the predicted and measured outflow from the leach facility based on the actual leaching records. Figure 10-3 and Figure 10-4, respectively, show the daily and cumulative drainages predicted in the model compared to the actual measured values. Both figures show excellent correlation indicating the model calibration is accurate. The saturated hydraulic conductivity value (Ksat) that was arrived at from calibration of heap drainage was determined to be 13.3 ft/day compared to the 39 ft/day predicted in initial test work described in the 2018 FS Report. This suggests the ore is less permeable than expected likely due to an increased clay content of material placed to date combined with a higher percentage of un-agglomerated ROM ore compared to the original mine plan, but the overall agreement of the model prediction to actual allows the extraction from all ore types to be assessed.





**Figure 10-3: Daily Drainage Flow Rate Comparison (Forte, 2020)**



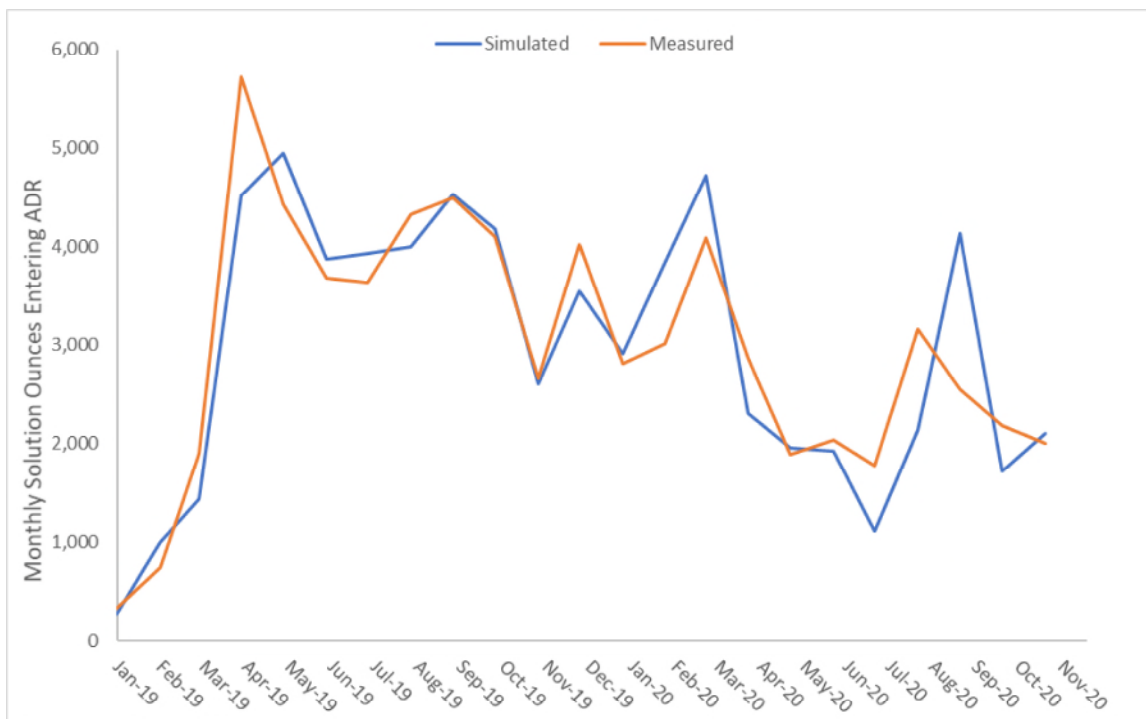
**Figure 10-4: Cumulative Drainage Flow Rate Comparison (Forte, 2020)**

### 10.2.2 Gold Bar North Gold Extraction Analysis

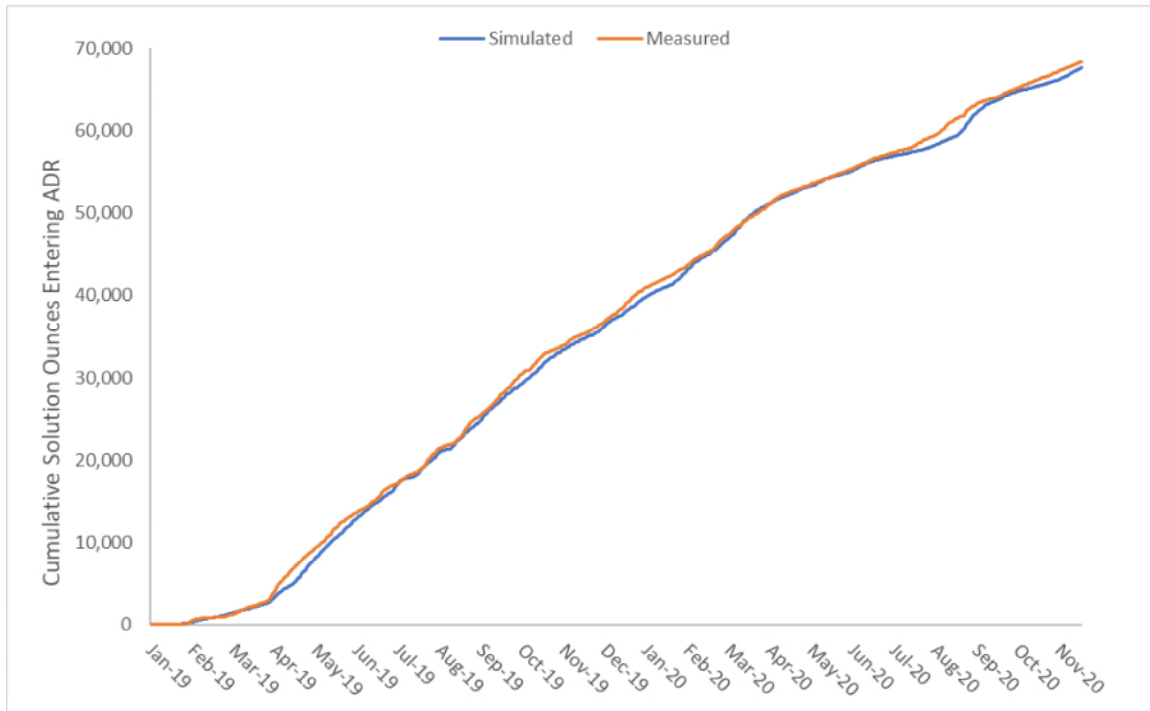
The 2018 FS included an ultimate gold extraction of 82% from Gold Bar North ore. This value assumed 100% of the ore to be crushed to minus 6-inch and the minus 3-inch fraction to be agglomerated prior to stacking. As noted, actual ore loading has consisted of a mixture of crushed and agglomerated ore, and ROM ore which has resulted in an impact

to the expected recovery. Forte’s production leaching model was used to update the extraction estimates based on actual performance.

The initial extraction curves presented in the 2018 FS were loaded into the model and then adjusted for each ore type following the process depicted in Figure 10-2 to match the actual production schedule more closely. The resulting calibration values are much more accurate than what is predicted by laboratory testing. Figure 10-5 and Figure 10-6, respectively, show the monthly and cumulative gold production predicted in the model compared to the actual measured values. The results show excellent correlation and indicate an average of 78% recovery of crushed oxide ore and 72% recovery for ROM. Table 10-1 summarizes the expected recovery for ore types defined for the Gold Bar North deposit. Figure 10-7 shows the predicted extraction rates resulting from the calibration. It should be noted that these represent the rate of gold extraction. Unlike conventional recovery-by-month relationships used to estimate production, these curves are used in conjunction with the hydrodynamic relationships described above to predict production. It should also be noted that additional testing is underway including to further define diffusion extraction rates and determine if adjustment to the crush size can enhance extraction properties.



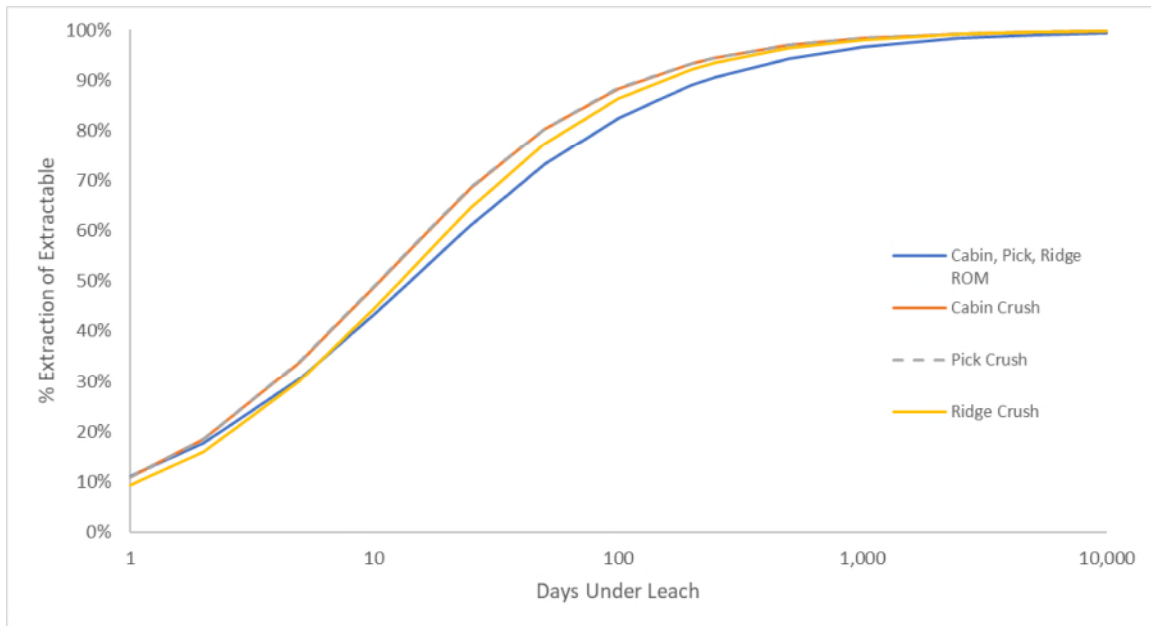
**Figure 10-5: Monthly Gold Production Comparison (Forte, 2020)**



**Figure 10-6: Cumulative Gold Production Comparison (Forte, 2020)**

**Table 10-1: Summary of Expected Recovery for Gold Bar North Ore Types**

| Ore Type    | Description  | Recovery |
|-------------|--|----------|
| Waste       | Gold grade less than ROM cut-off grade (au<0.007) & a classification (CLASS) of CLASS>2  | N/A      |
| Oxide ROM   | All material not designated as clay (clayint>1.5), high Sulphur (Sulf=1), or high Carbon (carbint>1.5), CLASS<3 & with au<=0.022, the designated ROM Crush cutover | 72%      |
| Oxide Crush | All material not designated as clay, high Sulf, or high Carbon and with au<=0.022  | 78%      |
| Mid Carbon  | Material model parameter 1.5>carbint<=2.5. carbint has decimals in the block model   | 50%      |
| High Carbon | Material model parameter carbint>2.5.  | 0%       |
| Sulf        | Material model parameter Sulf=1 (S>= 0.5%). Sulf has values of 0 or 1 in the block model   | 0%       |
| Mid Clay    | Material model parameter 1.5>clayint<=2.5. clayint has decimals in the block model   | 78%      |
| High Clay   | Material model parameter clayint>2.5.  | 78%      |



**Figure 10-7: Gold Bar North Extraction Rate Comparison (Forte, 2020)**

### **10.3 GOLD BAR NORTH – BASIS OF KEY PROCESS DESIGN CRITERIA**

#### **10.3.1 Precious Metal Recovery**

The 2018 FS plan included primary crushing to 100% minus 6-inch followed by screening and agglomeration of the minus 3-inch fraction. Agglomeration is appropriate for material with greater than 5% clay content but is largely ineffective in ores with clay contents below this level. The current mine block model shows that clay content is expected to drop below 5% in 2021 and that the agglomeration circuit will not be necessary after this point. The circuit will remain in place in the event that higher clay ores are encountered, and agglomeration is appropriate.

#### **10.3.2 Leach Feed Size**

ROM material will be placed on the leach pad as-delivered or crushed to 100% minus 6-inch depending on the grade. When appreciable clay content is encountered the crushed ore will be screened in a double deck vibrating screen. The minus 3-inch fraction will be agglomerated with cement and then recombined with the minus 6-inch/plus 3-inch (-6"/+3") fraction for loading onto the leach pad.

#### **10.3.3 Leach Recovery Rate**

The leach rate kinetics are very fast for all ore types. A cyanide concentration of 1.0 lb/t of solution with an industry standard application rate of 0.002-0.004 gpm/ft<sup>2</sup> is adequate to achieve optimum recovery and recovery rate based on the column test work and the recent production model calibration.

#### **10.3.4 Heap and Lift Height**

The heap lift height recommendation is a conservative 20-foot high at steady state and based on benchmarking other operations. Based on the compacted load permeability test work, a total heap height of 200 feet is acceptable for all ore types.

**10.3.5 Reagent Consumption**

As detailed in the 2018 FS, the large-scale 36-inch column consumed 0.29 lbs NaCN/ton, and the 24-inch columns with crushed ore cyanide consumption ranged from 0.34 to 2.08 NaCN lbs/ton. A conservative estimate of 0.40 lbs NaCN/ton ore is appropriate for full-scale operations.

Based on the compacted permeability tests from the 2017 KCA, cement required for agglomeration of the minus 3-inch size fraction is expected to be 20.0 lbs cement/ton agglomerated ore.

**10.4 GOLD BAR SOUTH**

Gold Bar South was formerly referred to as the Afgan deposit. The deposit has not been characterized to the same level of Gold Bar North. The 2018 FS included available data compiled by MDA in their report dated June 13, 2011 for the Afgan-Kobeh deposit. An ultimate extraction of 82% for Gold Bar South was put forth in the 2018 FS assuming the same processing considerations described for Gold Bar North, though the test work showed extractions ranging from 36% to 98%. Additional drilling was completed in 2019 along with additional column leach testing.

**10.4.1 2019 KCA Metallurgical Testing**

Drill core for the 2019 campaign was sent to Kappes Cassiday and Associates (KCA) for metallurgical testing. KCA prepared a composite sample by combining core from sixty-five intervals. The gold extraction from the ore was assessed by bottle roll testing at two different crush sizes (80% passing 150-mesh and 80% passing 10-mesh) as well as duplicate column tests with material crushed to minus 3-inch.

The bottle roll tests showed extractions of 64% and 91% with higher extraction at smaller crush size. The sodium cyanide consumptions were 0.16 and 0.25 lbs/ton. The material utilized in leaching was blended with 1.00 or 3.50 lbs/ton of hydrated lime.

For the column leach test work, gold extractions were 59% to 67% at 180 days of leaching based on calculated heads of 0.0353 to 0.0391 oz/ton. The sodium cyanide consumptions were 2.92 and 3.02 lbs/ton, respectively. The material utilized in leaching was blended with 2.93 or 3.00 lbs/ton of hydrated lime.

When comparing the gold extractions across the test program, the 10-mesh material leached for four (4) days showed a similar gold extraction (64%) to the average gold extraction between the two (2) column leach tests utilizing material crushed to 100% passing 3 inches leached for 180 days (63%). However, the pulverized material showed an extraction of 91%, indicating a size-dependence in the extraction.

**Table 10-2: Summary of 2019 KCA Bottle Roll Leach Tests**

| Description               | Feed Size, mm | Duration, hours | Head Assay, oz Au/ton | Calculated Head, oz Au/ton | Au Extracted % | Consumption, NaCN lbs/ton | Addition Ca(OH) <sub>2</sub> , lbs/ton |
|---------------------------|---------------|-----------------|-----------------------|----------------------------|----------------|---------------------------|--|
| Composite South Area Core | 0.074         | 96              | 0.0326                | 0.0327                     | 91%            | 0.25                      | 3.5                                    |
| Composite South Area Core | 1.7           | 96              | 0.0326                | 0.0284                     | 64%            | 0.16                      | 1                                      |

**Table 10-3: Summary of 2019 KCA Column Leach Tests**

| Description                                  | Feed Size, inch | Duration, Days | Head Assay, oz Au/ton | Calculated Head, oz Au/ton | Au Extracted, % | Consumption NaCN, lbs/ton | Addition Ca(OH) <sub>2</sub> , lbs/ton |
|--|-----------------|----------------|-----------------------|----------------------------|-----------------|---------------------------|--|
| Composite South Area Core, 83043 A - Split A | 1.73            | 180            | 0.0326                | 0.0353                     | 59%             | 2.92                      | 2.93                                   |
| Composite South Area Core, 83043 A - Split B | 1.73            | 180            | 0.0326                | 0.0391                     | 67%             | 3.02                      | 3.00                                   |

#### **10.4.2 Gold Bar South Recovery Projection**

Material from Gold Bar South deposit is scheduled to be placed as ROM in the current mine plan. The expected blasting fragmentation for the Gold Bar South project is expected to result in a size distribution with a P<sub>80</sub> of approximately 4-inch. Based on this and the apparent size dependence in extraction, an ultimate extraction of 61% is predicted following consideration of the expected liberation and diffusion properties. Additional test work is underway including VAT leach testing at Forte Analytical to further investigate an optimal P<sub>80</sub> and associated extraction.

## **11 MINERAL RESOURCE ESTIMATES**

### **11.1 INTRODUCTION – QUALIFIED PERSONS**

This Report provides a mineral resource estimate and a classification of resources reported in accordance with the CIM Definition Standards for Mineral Resources and Mineral Reserves. Accordingly, the Mineral Resources have been classified as Indicated Mineral Resources or Inferred Mineral Resources. The Technical Report Summary authors consider that the classification scheme as implemented is compliant with regulation S-K §229.1302 standards. The Mineral Resource estimate and related geologic modeling were reviewed and approved by Michael Baumann, C.P.G. of McEwen Mining Inc, Elko, Nevada. Mr. Baumann is a Qualified Person, and not independent of McEwen for purposes of NI 43-101.

Four independent block models were constructed for this Project. The previous model completed for Gold Bar North with an effective date of July 9, 2015, was broken up into three independent resource estimates for Gold Pick, Gold Ridge and Cabin. The Gold Bar South (formerly Afgan) last updated in 2018 is also updated in this report. The Mineral Resource Statement, provided in subsection 14.18 of this report is a combined statement for Gold Pick, Gold Ridge, Cabin and Gold Bar South. The sub-sections leading into the resource statement have been grouped to present the details for each deposit area.

The Mineral Resource estimates were based on a 3D geological model of major structural features and geologically controlled alteration and mineralization. In the Gold Pick and Gold Ridge areas, a total of 78 mineral (estimation) domains defined using structural offset of stratigraphic units were interpreted from mineralized drill intercepts, comprised mostly of 5 ft reverse circulation samples. Cabin is comprised of another 42 domains.

The block size of each model is 20 ft x 20 ft x 20 ft. All models are in Imperial units. For the main Gold Pick deposit and Gold Ridge deposits, gold was estimated into model blocks using the Ordinary Kriging (OK), OK with dynamic anisotropy and Inverse Distance Weighted (IDW) interpolation methods. Fill was modeled by comparing a current to a pre-mining topographic surface. Potentially deleterious material was modeled using cyanide soluble to fire assay ratios (CN:FA) for gold, carbon intensity logs, organic carbon analysis and sulfide analysis. Density was derived from historic production, and from 2011 and 2020 measurements of drill core.

The resource estimate for GBS used 42 interpolation domains representing structural offsets of the stratigraphic contacts derived by geologic logging. Ten-foot composites were used to inform blocks with XYZ dimensions of 20 ft x 20 ft x 20 ft, respectively. The model is in U.S. units. Gold was estimated into model blocks using the IDW interpolation method and dynamic anisotropy. There is no historic mining at GBS and the rock mass is considered oxidized or unaltered. Density was assigned based on stratigraphic unit and alteration. Density was derived from testing completed in 2019 and 2020 on drill core.

### **11.2 GOLD PICK BLOCK MODEL**

McEwen constructed contiguous block models for Gold Pick and Gold Ridge that were merged after interpolation into the model extents defined in Table 11-1.

**Table 11-1: Gold Pick and Gold Ridge 2020 Resource Model Extents**

| Coordinates | Min (ft)   | Max (ft)   | Block Size (ft) | Number of Blocks |
|-------------|------------|------------|-----------------|------------------|
| East        | 1,821,170  | 1,829,130  | 20              | 398              |
| North       | 14,452,020 | 14,457,000 | 20              | 249              |
| Elevation   | 6,200      | 9,100      | 20              | 145              |

Source: McEwen, 2020

The block size of 20 ft x 20 ft x 20 ft was considered appropriate for the deposit based on the drilling density, data quality and the anticipated open-pit mining fleet.

The 2020 version of the Gold Pick block model was constructed in imperial units (feet). The coordinate system for the 2020 block model is NAD83 meters scaled to feet.

### 11.3 GOLD PICK ASSAY DATA POPULATION DOMAIN ANALYSIS AND CAPPING

The Gold Pick assay database used in this study consisted of 1,807 drill holes and approximately 150,000 gold assay intervals. The cut-off date for data used in this resource estimate was October 29, 2020.

Most of the drilling supporting the resource estimate was performed using RC methods with minimal core drilling (~2%). However, when core drilling has been used, as described in Section 9.1 of this report, correlations are adequate to good, providing sufficient confidence for application of the data in resource modeling. RC drilling for all of Gold Bar has been above the water table; therefore, there are no issues related to drilling wet RC holes in the database.

Using lognormal probability plots and percentile analysis as guides, in conjunction with an examination of the distribution of drill hole data, metal removed, and effect on domain coefficient of variance, capping thresholds were selected for each interpolation domain for Gold Pick. An inflection point on each probability plot was selected to identify assays that are to be considered “outliers” to the general distribution and then compared to percentile analysis break points Assays were “capped” or set back to the defined threshold. The thresholds identified are tabulated below in Table 11-2.

**Table 11-2: Gold Pick Assay Capping Statistics by Interpolation Domain**

| Domains | Au Cap (ppm) | No. Samples Capped | Domains | Au Cap (ppm) | No. Samples Capped | Domains | Au Cap (ppm) | No. Samples Capped |
|---------|--------------|--------------------|---------|--------------|--------------------|---------|--------------|--------------------|
| 358     | 1            | 17                 | 517     | 2.86         | 31                 | 548     | 0.15         | 5                  |
| 401     | 5            | 20                 | 518     | 5.54         | 11                 | 550     | 1.1          | 12                 |
| 418     | 5.65         | 21                 | 520     | 2.01         | 41                 | 551     | 0.61         | 9                  |
| 473     | 1.61         | 33                 | 521     | 1.8          | 13                 | 553     | 4.59         | 23                 |
| 480     | 2.22         | 10                 | 522     | 2.3          | 19                 | 559     | 5            | 20                 |
| 482     | 1.1          | 10                 | 524     | 3            | 41                 | 560     | 4.3          | 26                 |
| 483     | 3.82         | 66                 | 525     | 1.54         | 15                 | 562     | 6.5          | 28                 |
| 484     | 3.24         | 12                 | 526     | 5            | 24                 | 563     | 3            | 70                 |
| 487     | 2.79         | 25                 | 527     | 2.61         | 26                 | 564     | 0.28         | 17                 |
| 489     | 1.5          | 55                 | 528     | 3.85         | 13                 | 565     | 6.5          | 11                 |
| 490     | 5            | 32                 | 529     | 2.48         | 30                 | 566     | 7            | 18                 |
| 491     | 4.68         | 20                 | 530     | 4.8          | 20                 | 567     | 5.5          | 12                 |



**GOLD BAR PROJECT**  
**FORM 43-101F1 TECHNICAL REPORT – FEASIBILITY STUDY**

| Domains | Au Cap (ppm) | No. Samples Capped |
|---------|--------------|--------------------|
| 492     | 5            | 80                 |
| 498     | 2.5          | 48                 |
| 511     | 3.3          | 22                 |
|         |              |                    |

| Domains | Au Cap (ppm) | No. Samples Capped |
|---------|--------------|--------------------|
| 542     | 6            | 22                 |
| 543     | 1.3          | 14                 |
| 546     | 0.4          | 30                 |
| 547     | 0.9          | 15                 |

| Domains | Au Cap (ppm) | No. Samples Capped |
|---------|--------------|--------------------|
| 568     | 2.2          | 20                 |
| 569     | 0.76         | 17                 |
| 570     | 3            | 44                 |
| 571     | 4            | 11                 |

Source: McEwen 2020

**11.4 GOLD PICK COMPOSITING**

After capping, the Au sample grades were composited to 5 ft fixed length intervals. After compositing, the composites were coded with the majority domain code. Table 11-3 summarizes the composite statistics.

**Table 11-3: Gold Pick Composite Statistics**

| Domain | No. Intervals | Minimum | Maximum | Mean  | Standard deviation | CV    | % Reduction applied to CV by Capping |
|--------|---------------|---------|---------|-------|--------------------|-------|--------------------------------------|
| 358    | 2312          | 0.002   | 1       | 0.037 | 0.116              | 3.175 | 59%                                  |
| 401    | 1951          | 0.002   | 5       | 0.338 | 0.774              | 2.291 | 16%                                  |
| 418    | 2127          | 0.001   | 5.65    | 0.326 | 0.81               | 2.483 | 13%                                  |
| 473    | 2504          | 0.001   | 1.61    | 0.097 | 0.261              | 2.691 | 25%                                  |
| 480    | 1467          | 0.003   | 2.22    | 0.109 | 0.274              | 2.515 | 24%                                  |
| 482    | 2589          | 0.002   | 1.1     | 0.025 | 0.089              | 3.509 | 15%                                  |
| 483    | 2532          | 0.002   | 3.82    | 0.258 | 0.751              | 2.906 | 30%                                  |
| 484    | 3661          | 0.001   | 3.24    | 0.044 | 0.257              | 5.849 | 27%                                  |
| 487    | 1366          | 0.003   | 2.79    | 0.291 | 0.581              | 1.999 | 12%                                  |
| 489    | 11523         | 0.001   | 1.5     | 0.045 | 0.157              | 3.505 | 27%                                  |
| 490    | 1787          | 0.001   | 5       | 0.491 | 0.991              | 2.019 | 11%                                  |
| 491    | 1253          | 0.003   | 4.68    | 0.48  | 0.927              | 1.93  | 14%                                  |
| 492    | 3128          | 0.002   | 5       | 0.421 | 1.054              | 2.504 | 19%                                  |
| 498    | 1692          | 0.001   | 2.5     | 0.216 | 0.544              | 2.518 | 24%                                  |
| 511    | 4202          | 0.002   | 3.3     | 0.089 | 0.332              | 3.729 | 16%                                  |
| 517    | 2018          | 0.003   | 2.86    | 0.355 | 0.603              | 1.699 | 57%                                  |
| 518    | 1489          | 0.003   | 5.54    | 0.661 | 1.058              | 1.6   | 9%                                   |
| 520    | 9259          | 0.003   | 2       | 0.093 | 0.249              | 2.686 | 14%                                  |
| 521    | 3594          | 0.002   | 1.8     | 0.052 | 0.195              | 3.731 | 17%                                  |
| 522    | 2155          | 0.003   | 2.3     | 0.086 | 0.297              | 3.468 | 31%                                  |
| 524    | 2957          | 0.002   | 3       | 0.189 | 0.489              | 2.578 | 16%                                  |
| 525    | 1159          | 0.002   | 1.54    | 0.08  | 0.23               | 2.879 | 27%                                  |
| 526    | 1839          | 0.003   | 5       | 0.506 | 0.968              | 1.912 | 6%                                   |
| 527    | 949           | 0.003   | 2.6     | 0.304 | 0.609              | 2.006 | 12%                                  |
| 528    | 927           | 0.003   | 3.85    | 0.198 | 0.588              | 2.975 | 20%                                  |
| 529    | 998           | 0.003   | 2.5     | 0.273 | 0.537              | 1.971 | 13%                                  |
| 530    | 992           | 0.003   | 4.8     | 0.481 | 0.996              | 2.07  | 12%                                  |
| 542    | 1035          | 0.003   | 6       | 0.728 | 1.261              | 1.732 | 15%                                  |
| 543    | 1394          | 0.003   | 1.3     | 0.058 | 0.179              | 3.088 | 55%                                  |

**GOLD BAR PROJECT**  
**FORM 43-101F1 TECHNICAL REPORT – FEASIBILITY STUDY**

| Domain | No. Intervals | Minimum | Maximum | Mean  | Standard deviation | CV    | % Reduction applied to CV by Capping |
|--------|---------------|---------|---------|-------|--------------------|-------|--------------------------------------|
| 546    | 2884          | 0.001   | 0.4     | 0.021 | 0.056              | 2.622 | 22%                                  |
| 547    | 2035          | 0.001   | 0.9     | 0.027 | 0.105              | 3.838 | 33%                                  |
| 548    | 1151          | 0.002   | 0.15    | 0.01  | 0.019              | 1.823 | 33%                                  |
| 550    | 603           | 0.001   | 1.1     | 0.073 | 0.185              | 2.549 | 38%                                  |
| 551    | 461           | 0.001   | 0.61    | 0.059 | 0.122              | 2.062 | 38%                                  |
| 553    | 1529          | 0.003   | 4.6     | 0.337 | 0.85               | 2.523 | 11%                                  |
| 559    | 1892          | 0.001   | 5       | 0.364 | 0.776              | 2.133 | 14%                                  |
| 560    | 4106          | 0.002   | 4.3     | 0.168 | 0.573              | 3.403 | 17%                                  |
| 562    | 1800          | 0.003   | 6.5     | 0.896 | 1.412              | 1.576 | 3%                                   |
| 563    | 2842          | 0.003   | 3       | 0.378 | 0.654              | 1.732 | 3%                                   |
| 564    | 1505          | 0.003   | 0.28    | 0.018 | 0.043              | 2.434 | 40%                                  |
| 565    | 1336          | 0.001   | 6.5     | 0.257 | 0.807              | 3.135 | 9%                                   |
| 566    | 3951          | 0.002   | 7       | 0.183 | 0.703              | 3.834 | 6%                                   |
| 567    | 2543          | 0.002   | 5.5     | 0.394 | 0.796              | 2.02  | 3%                                   |
| 568    | 1235          | 0.003   | 2.2     | 0.224 | 0.447              | 1.992 | 14%                                  |
| 569    | 1163          | 0.002   | 0.76    | 0.066 | 0.129              | 1.974 | 19%                                  |
| 570    | 2412          | 0.002   | 3       | 0.232 | 0.505              | 2.177 | 29%                                  |
| 571    | 1824          | 0.001   | 4       | 0.185 | 0.517              | 2.793 | 54%                                  |

Source: McEwen, 2020

**11.5 GOLD PICK GEOMETALLURGICAL MODELING**

McEwen recovers gold by using sodium cyanide (NaCN) in a heap leach operation. Historic and recent metallurgical testing indicates that mineralization, which is un-oxidized, decalcified, high-carbon, or high-sulfide has reduced or refractory recovery characteristics. Areas of material characterized by potential reduced or refractory recovery were identified and modeled by incorporating additional aspects such as:

- Carbon (high, moderate, and low) intensity
- Sulfide (Total Sulfur >0.3% or Sulfide Sulfur >0.1%)
- Cn/FA assay ratios

A risk variable was then assigned to the block model based on the criteria summarized in Table 11-4. Economic parameters were then assigned based on the risk assessment. Silicification was also reviewed for Gold Pick and not found to be in sufficient quantities as to affect heap leach recovery.

**Table 11-4: Gold Pick Recovery Model Risk Categorization**

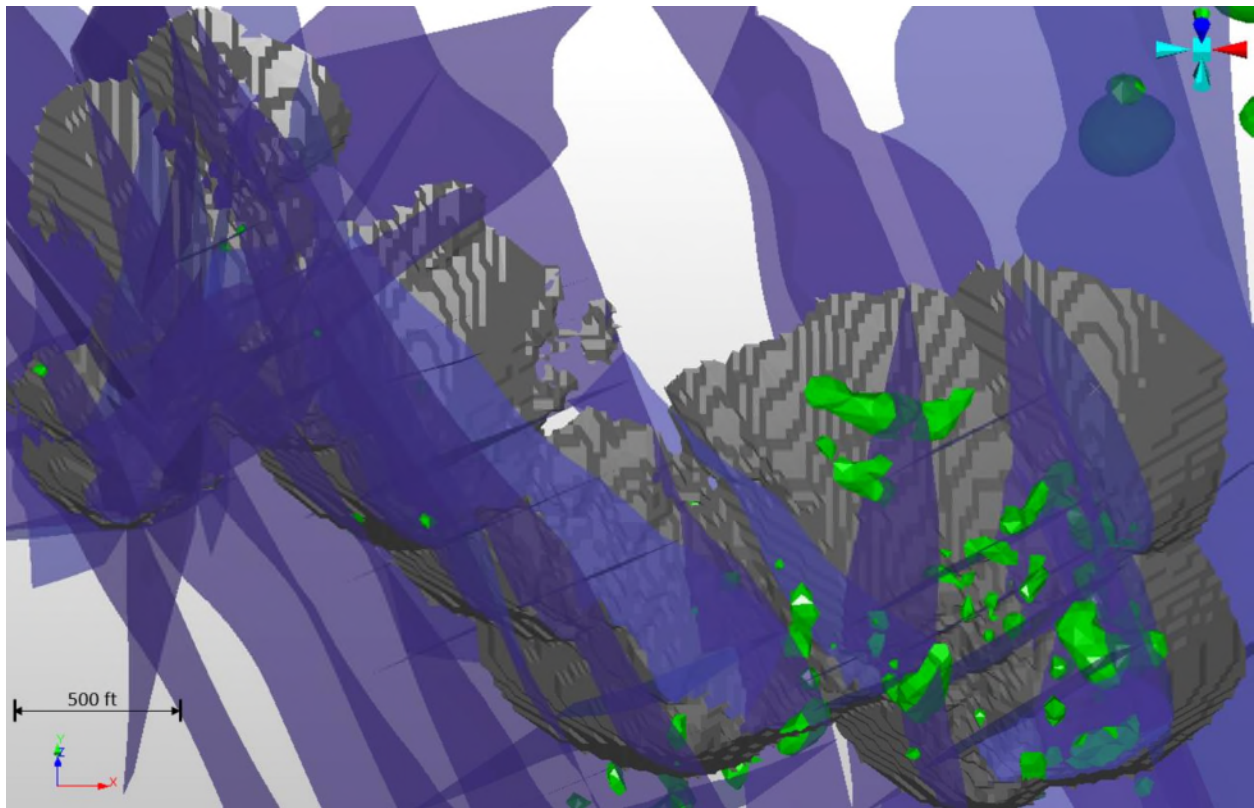
| Material Type Risk Categorization                                   | Low | Low | Moderate | High |
|---|-----|-----|----------|------|
| Oxide   | 0   |     |          |      |
| Sulfide Indicator of 1 (if %Tsulfur >=0.3% or Sulfide Sulfur >0.1%) |     |     |          | 3    |
| Carbon --- if intensity >=1 and <2                                  |     |     | 2        |      |
| Carbon -- if Intensity >=2  |     |     |          | 3    |
| If 50 < AuRecPct <= 70%   |     | 1   |          |      |
| If 25 < AuRecPct <= 50%   |     |     | 2        |      |
| If AuRecPct < 25%   |     |     |          | 3    |

Source: McEwen, 2020

The carbon model was created by combining the qualitative carbon intensity values (1-3, 3 being high) with quantitative organic carbon analytical values based on the assessment of recovery completed by Forte Dynamics as follows:

- Organic Carbon % <0.3 assigned an intensity of 1
- Organic Carbon % 0.3 – 0.6 assigned an intensity of 2
- Organic Carbon % > 0.6 assigned an intensity of 3

Intensity values were then modeled as indicator isoshells for intensity 1,2, and 3 using Leapfrog Geo v5.1. The occurrence of carbon pods appears to be coincident with faulting and can be in the hanging wall or foot wall of faults. Carbonaceous pods are of variable thickness. Controlling trends were applied using the fault structure model. The resulting isoshells shown in Figure 11-1 were then imported to Studio RM and the block model field Carb\_Int was coded from the isoshells.



**Figure 11-1: Oblique view, Gold Pick carbonaceous areas intensity >2 (McEwen, 2020)**

The sulfide model was constructed using a combination of ICP Total Sulfur % data and Sulfide Sulfur % data. Using thresholds determined by Forte Dynamics, an indicator isoshell model was created in Leapfrog Geo v5.1 by combining Total Sulfur % > 0.30% and Sulfide Sulfur % > 0.10% to represent sulfide mineralization that potentially affects recovery. It was determined that sulfides are most probably associated with mineralization and silicification encountered within the fault zones and are limited within the deposit as shown in Figure 11-2.

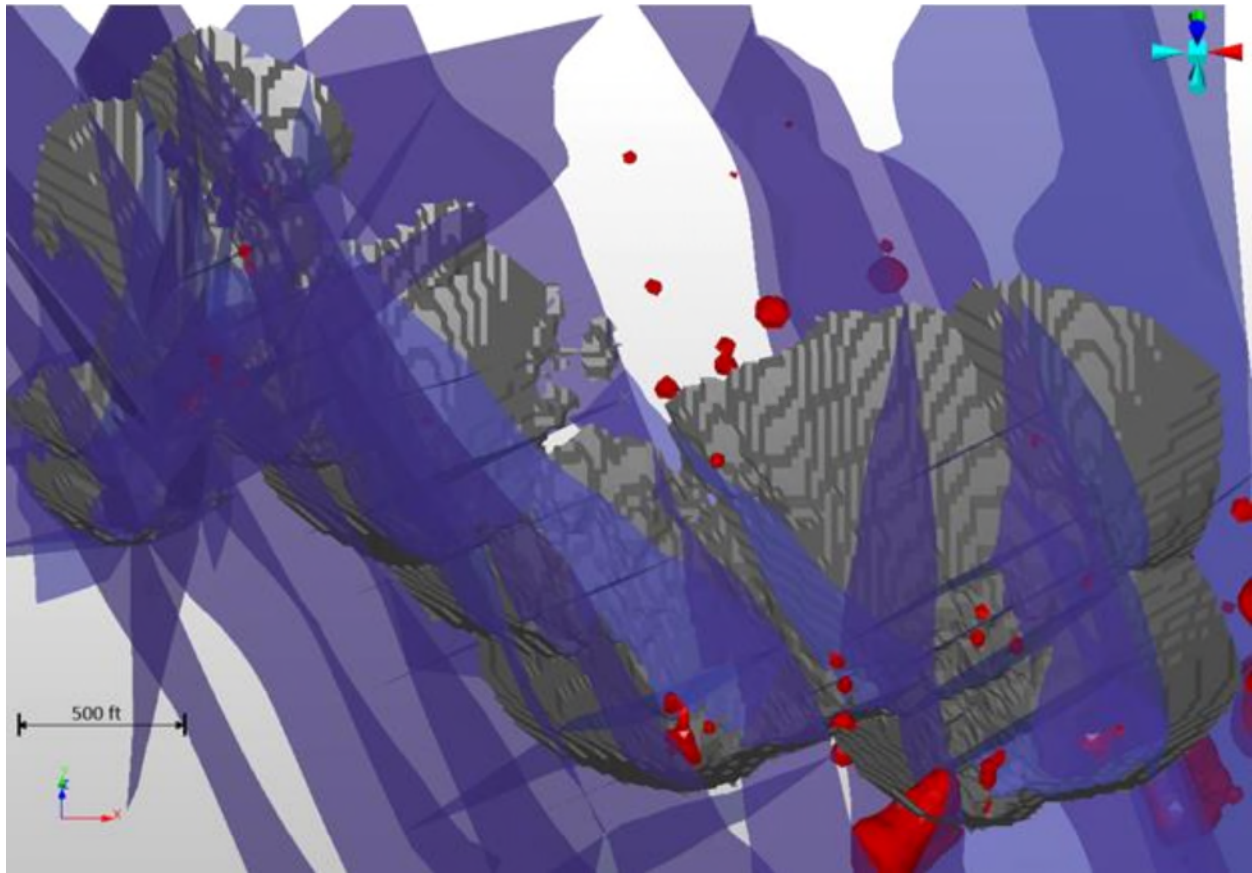


Figure 11-2: Oblique view, Gold Pick sulfide pods (McEwen, 2020)

CN/FA ratios were then used to populate the block model in areas where carbon and sulfide data is not available. The recovery model was created using the same interpolation methodology as the gold resource estimate. The results of the model were then used to populate the risk code as shown in Table 11-4.

#### 11.6 GOLD PICK HISTORIC MINING DUMPS

To account for the fill material left in dumps from previous mining, wireframe solids were created and coded to the model using a 50% minimum block rule. A 'Fill' attribute was then coded from the solid and the fill code was copied into the final model Domain field. Fill blocks were excluded from insitu tons and grade calculations.

#### 11.7 GOLD PICK DENSITY

Density was assigned to the block model based on previous analyses outlined in the prior FS completed in 2018 (M3, 2018). A density value of 13.35 ft<sup>3</sup>/t was assigned to material with a grade  $\geq 0.005$  opt. The lower average density of the oxide ore is a function of decalcification, argillization and oxidation. Any blocks coded as fill were then assigned a tonnage factor of 16.7 ft<sup>3</sup>/t. A summary of Tonnage Factors by rock type is provided in Table 11-5.

**Table 11-5: Gold Pick Tonnage Factors by Rock Type**

| <b>Rock Type</b>      | <b>Tonnage Factor ft<sup>3</sup>/ton</b> |
|-----------------------|--|
| Waste Rock            | 12.81                                    |
| Mineralized Oxide     | 13.35                                    |
| Carbonaceous Material | 12.81                                    |
| Fill                  | 16.7                                     |

Source: SRK 2015

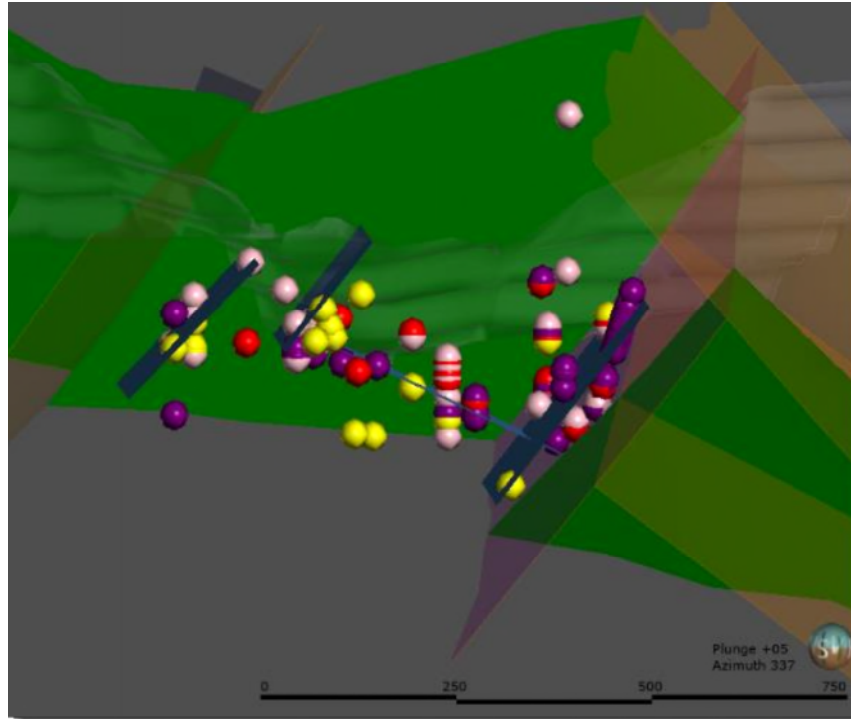
Additional test work is being conducted in 2020-2021 to better assign density by lithology and alteration.

### **11.8 GOLD PICK VARIOGRAPHY AND INTERPOLATION SEARCH CRITERIA**

The purpose of the domains is to divide the data into meaningful pods within the Bartine stratigraphic unit offset by faulting as illustrated in Figure 11-3. The northwest faults are the youngest in the system and are not mineralized but provide the greatest offsets. Northeast trending faults and fractures are both mineralized and offsetting. Boundary conditions test produced mixed results and results. The domain boundaries are considered hard boundaries based on visual offset of features and mineralized planes across the boundaries.

Variograms were constructed for the composited and capped assay values for each interpolation domain independently. To facilitate this work McEwen used the Snowden Supervisor tool kit to develop a series of variograms, for each mineral domain.





**Figure 11-4: Example of mineralized trends within Gold Pick Domain 492 (McEwen, 2020)**

To accommodate the different planes of mineralization within the deposit a dynamic anisotropic model was created. Mineralized planes were defined within each domain and the dip, dip direction and plunge of the planes were interpolated into each block using three search passes. Variography was then applied to the dominant gold trend within each domain to establish the search distances to be used for interpolation. Search distances listed in Table 11-6 were initially set to 70% of the distance to sill and then adjusted up or down based on review of multiple model runs. Gold isoshells were created at cut-off values of 0.005 opt and 0.003 opt to compare against the various models. Search distances were adjusted to minimize spread of mineralization beyond what was believed to be reliable distances from composites.

High angle faults are assumed to influence mineralization on a district scale in the Roberts Mountains and it is believed that such structures influence mineralization at Gold Bar. Within each deposit, other structural trends are also assumed to influence mineralization such as east or northeast trending structural controls at Gold Pick (SRK, 2012, Atlas, 1996). Atlas identified a large east-west-trending anticline along the center of the window of lower-plate rocks and several smaller east-west-trending anticlines have also been identified. MRDI (1995) noted that rocks at Gold Ridge are deformed in a gentle upright arch that plunges 22° towards 100° (SE). At Cabin Creek, the same east-plunging broad anticline continues from Gold Pick. A major NNW-trending fault brought the mineralized Cabin Creek block up. The strata in the Cabin Creek fault block dip considerably steeper than those at Gold Pick. Dips exist up to 56° to the east at Cabin Creek, while only about 30° at Gold Pick. MRDI reported that the principal result of their structural analysis in the Gold Pick pit was the finding that the average arch axis plunges approximately 35° toward the east. Project and district maps show a concentration of ore bodies along this arch trend. The arch, along with local feeder systems, was an important influence on mineralization.

**Table 11-6: Au Estimation Search Distances by Interpolation Domain for Gold Pick Estimation**

| Search Distances Applied |       |            |       | Search Distances Applied |       |            |       |
|--------------------------|-------|------------|-------|--------------------------|-------|------------|-------|
| Domain                   | Major | Semi-Major | Minor | Domain                   | Major | Semi-Major | Minor |
| 358                      | 120   | 62         | 100   | 527                      | 90    | 82         | 52    |
| 401                      | 49    | 27         | 24    | 528                      | 85    | 28         | 20    |
| 418                      | 34    | 37         | 32    | 529                      | 102   | 35         | 25    |
| 473                      | 108   | 103        | 52    | 530                      | 57    | 55         | 44    |
| 480                      | 65    | 37         | 19    | 542                      | 58    | 57         | 50    |
| 482                      | 42    | 39         | 16    | 543                      | 82    | 52         | 35    |
| 483                      | 93    | 72         | 40    | 546                      | 160   | 63         | 38    |
| 484                      | 36    | 38         | 12    | 547                      | 80    | 22         | 22    |
| 487                      | 218   | 88         | 76    | 548                      | 120   | 62         | 100   |
| 489                      | 135   | 85         | 75    | 550                      | 112   | 52         | 75    |
| 490                      | 95    | 88         | 80    | 551                      | 163   | 120        | 18    |
| 491                      | 89    | 51         | 49    | 553                      | 77    | 20         | 18    |
| 492                      | 41    | 37         | 8     | 559                      | 55    | 38         | 35    |
| 498                      | 99    | 86         | 59    | 560                      | 75    | 50         | 46    |
| 511                      | 69    | 38         | 25    | 562                      | 142   | 98         | 10    |
| 517                      | 88    | 50         | 11    | 563                      | 97    | 70         | 50    |
| 518                      | 95    | 125        | 60    | 564                      | 90    | 34         | 36    |
| 520                      | 60    | 30         | 90    | 565                      | 108   | 75         | 32    |
| 521                      | 68    | 38         | 19    | 566                      | 50    | 42         | 31    |
| 522                      | 44    | 42         | 12    | 567                      | 98    | 32         | 32    |
| 524                      | 40    | 42         | 22    | 568                      | 155   | 125        | 65    |
| 525                      | 72    | 80         | 35    | 569                      | 103   | 35         | 24    |
| 526                      | 92    | 72         | 38    | 570                      | 55    | 35         | 24    |
|                          |       |            |       | 571                      | 60    | 47         | 25    |

Source: McEwen 2020

## 11.9 GOLD PICK GRADE ESTIMATION

With the sample set available inverse distance cubed (ID<sup>3</sup>) and ordinary kriging (OK) interpolation methods were used to estimate blocks within each domain using search distances derived from variography and applied to the dip, dip direction and plunge assigned to each block from trend data. A nearest neighbor (NN) model was also created from 20-foot composites using the same search orientations and distances as the OK and ID<sup>3</sup> models for validation purposes.

To preserve grade relationship to source data and reduce smearing, a search neighborhood strategy with three search ellipse ranges was used. The first pass was limited to data close to the block at approximately 60-70% of the variogram range. Subsequent second and third search passes were increased in size by 2x the original distance and 2.5 times the original search distance. The search distances were adjusted by domain until the McEwen QP was satisfied that the blocks estimated represented an appropriate volume given the density of the source data and distance from mapped structures.



For each interpolation run, hard boundaries were applied to each block whereby a block in a given interpolation domain was not allowed to use composites from an adjacent interpolation domain if they fell within the search parameters of that block. Block grades on subsequent search passes were not allowed to overwrite previous estimates.

Parameter testing was completed using composite lengths (5 foot and 10 foot) composed of capped and uncapped samples, outlier restriction, varying minimum and maximum number of samples per search and varying block sizes (20x20x10 vs 20x20x20). Test results produced total ounce estimates within a range of +1.5% of the final model parameters chosen for final estimation.

**11.10 GOLD PICK MINERAL RESOURCE CLASSIFICATION**

Mineral Resources were classified into Measured, Indicated, and Inferred categories based on CIM Definition Standards. Parameters used for classification are listed in Table 11-7. Parameters for measured are not included as those blocks were reclassified as indicated.

**Table 11-7: Gold Pick Classification Parameters**

|                                      | Indicated | Inferred |
|--------------------------------------|-----------|----------|
| <b>Block Model Code</b>              | 2         | 3        |
| <b>Average Distance</b>              | ≤75       | ≤175     |
| <b>Minimum Number of Drill holes</b> | 3         | 2        |
| <b>Minimum Number of Samples</b>     | 5         | 4        |

Source: McEwen, 2020

Classification using a purely statistical approach occasionally produces artifacts—blocks that fail mathematical criteria but are clearly related to adjacent blocks. Therefore, to finalize classification, dilate-erode process was applied to the block model where Measured blocks are 'dilated' out 20 feet into surrounding blocks and then dilated back allowing surrounding blocks to 'smooth' the Measured classification. This process was then completed for Indicated and Inferred blocks. The process is run 6 times in varying order of classification and then reversed to erode then dilate the block values to produce 12 potential classification models. Statistics for the original and resulting block models were compared prior to choosing the 'best fit' smoothed classification model to ensure the blocks were still statistically apportioned correctly. Measured blocks were then reclassified as Indicated based on on-going work to determine density values and mineralogy that could potentially affect recovery.

An oblique view of model blocks with Au > 0.005 opt showing the distribution of Indicated (green) and Inferred (blue) categories is provided Figure 11-5.

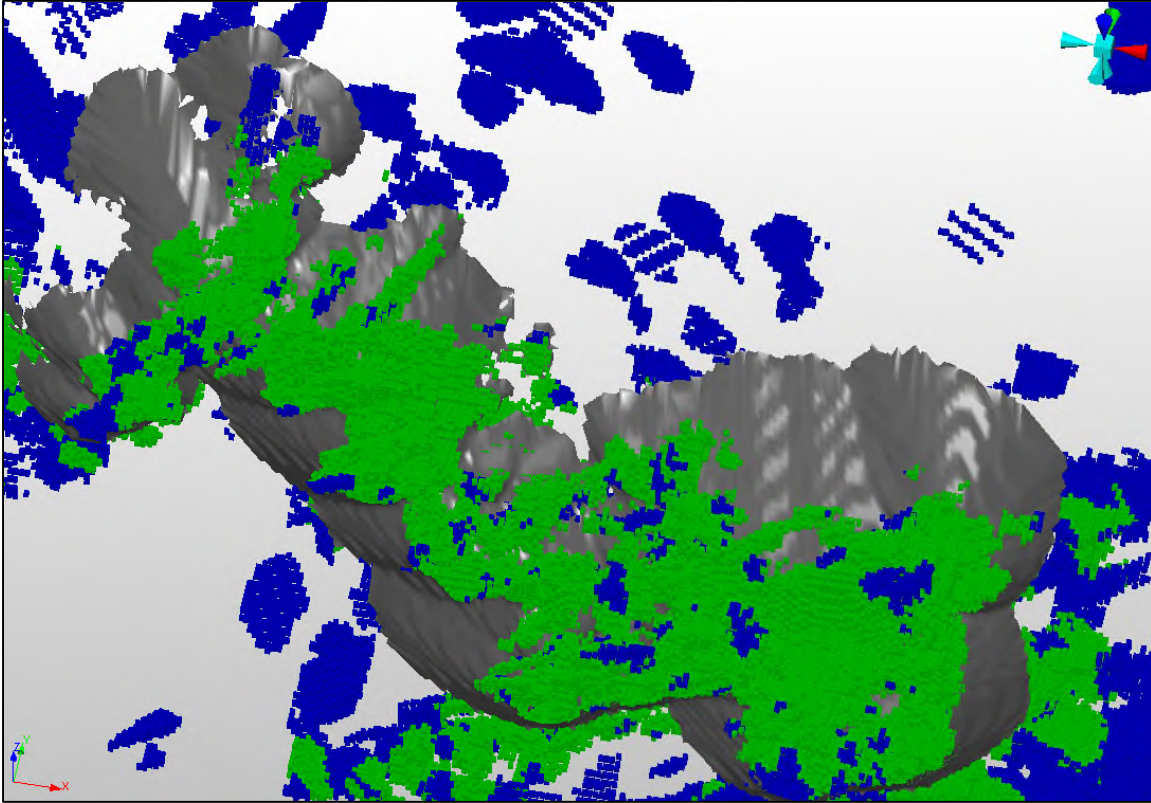


Figure 11-5: Gold Pick Estimated Blocks Colored by Classification Code (Green = Indicated, Blue = Inferred) (McEwen, 2020)

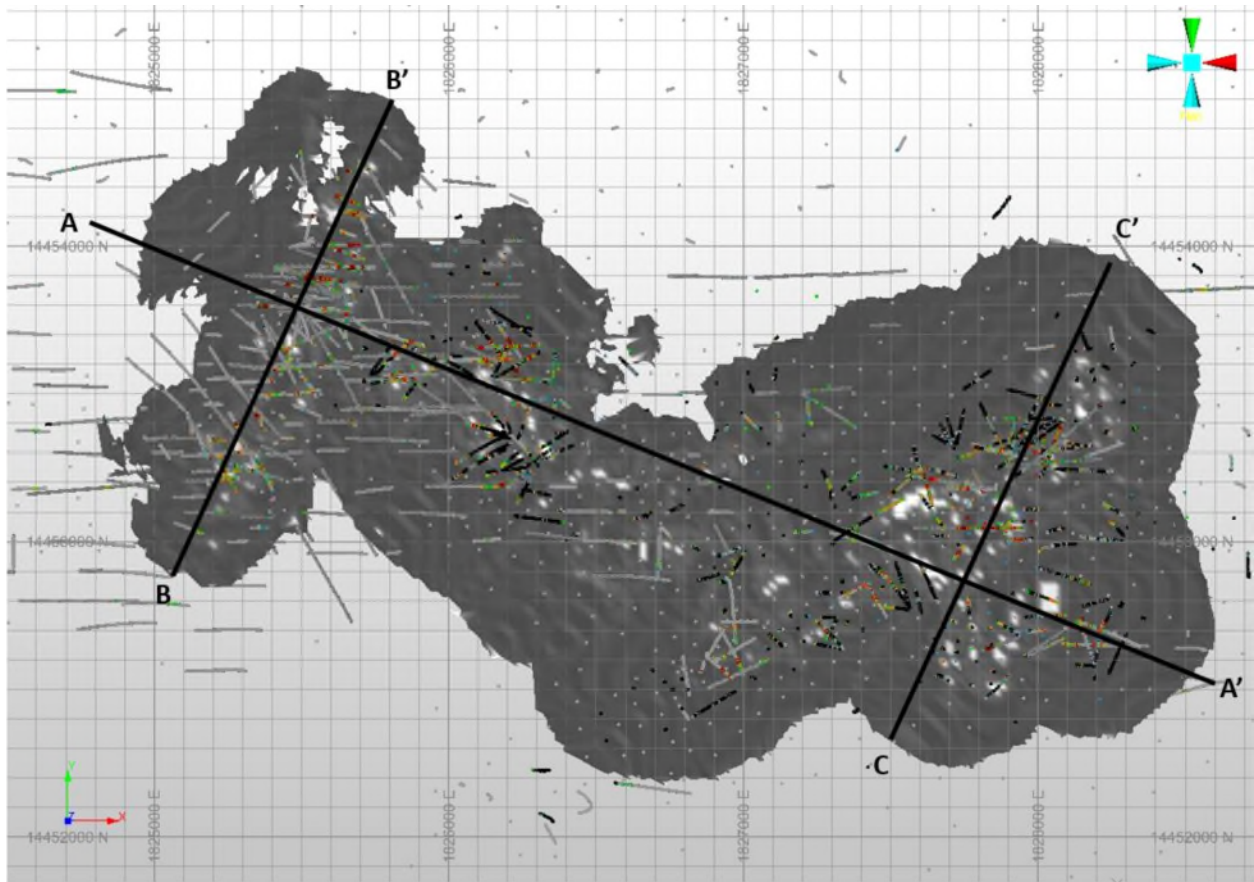
### 11.11 GOLD PICK BLOCK MODEL VALIDATION

Various measures were implemented to validate the Gold Pick block model. These measures included the following:

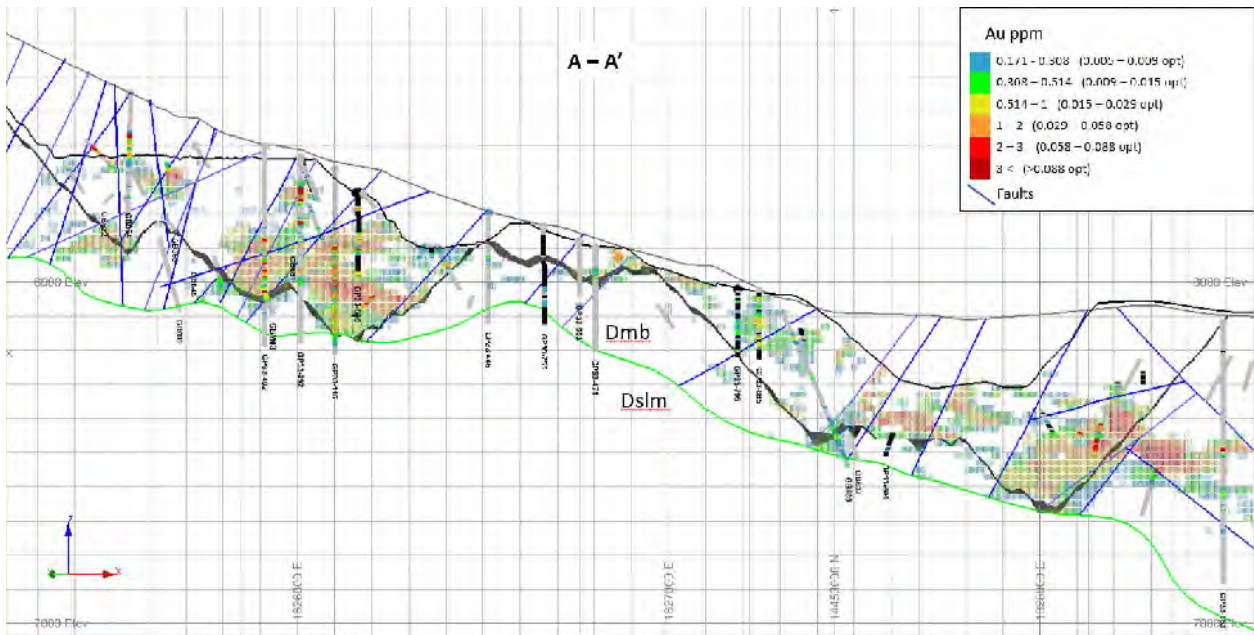
- Comparison of drill hole composites with resource block grade estimates from all zones visually in plan and section views;
- Statistical comparisons between block and composite data using distribution analyses;
- Statistical comparisons between the IDW, OK and NN models; and
- Swath plot analysis (drift analysis) comparing the inverse distance model with the NN model and declustered composite grades.
- Comparison to available ore control sampling

#### 11.11.1 Visual Comparison

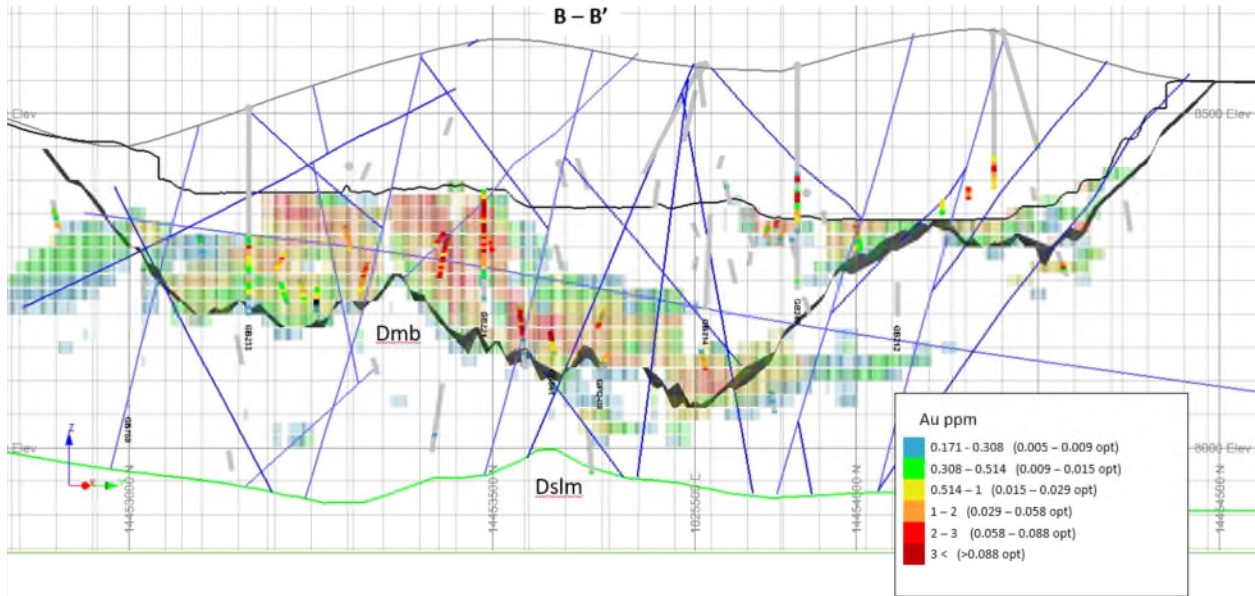
The estimated values of resource model blocks visually compare satisfactorily with composite values. Figure 11-6 provides a plan view of the resource pit and defines the locations of the cross sections. Figure 11-7 through Figure 11-9 provide cross sections showing the blocks colored by the IDW estimated Au oz/t values and the corresponding composite grades for drill hole intervals within 20 feet of the cross section. The green line represents the contact between the mineralized Bartine and the underlying Lone Mountain dolomite. Blue lines represent faults. The block model is clipped to the November, 2020 end of month topography. The gray ribbon represents the 2020 \$1750 resource pit shell.



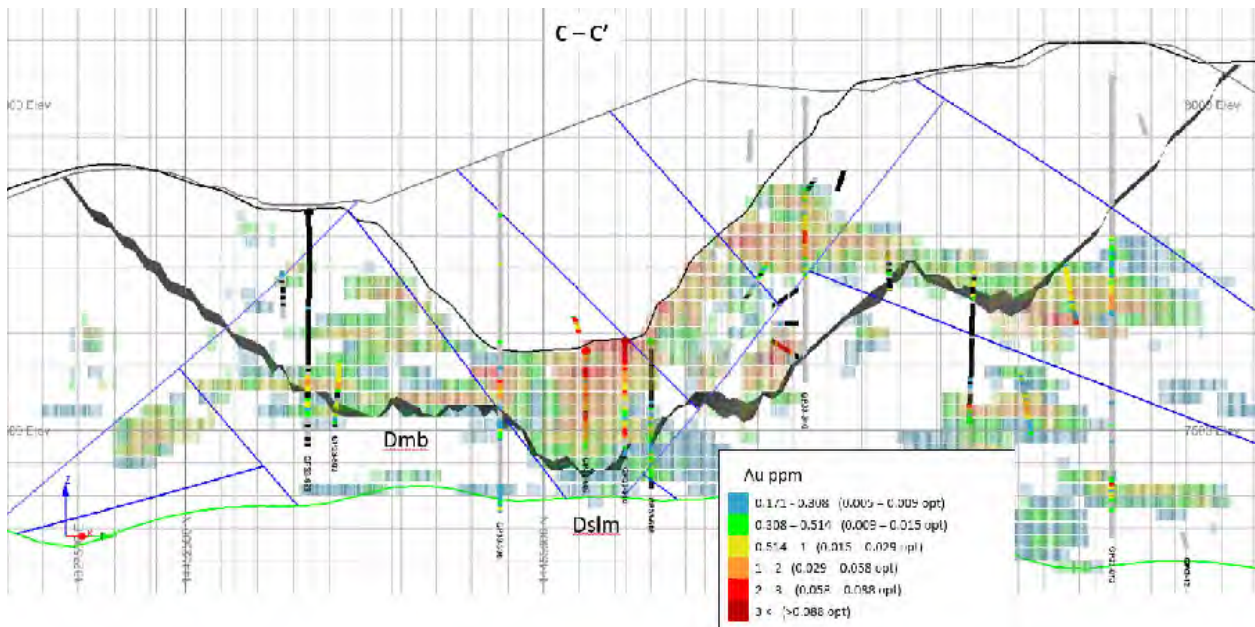
**Figure 11-6: Plan View of Visual Validation Cross Section Locations for Estimated Grades, Gold Pick (McEwen, 2020)**



**Figure 11-7: Section A-A' - Visual Validation of Estimated Gold Grades, Gold Pick (McEwen, 2020)**



**Figure 11-8: Section B-B' - Visual Validation of Estimated Gold Grades, Gold Pick (McEwen, 2020)**

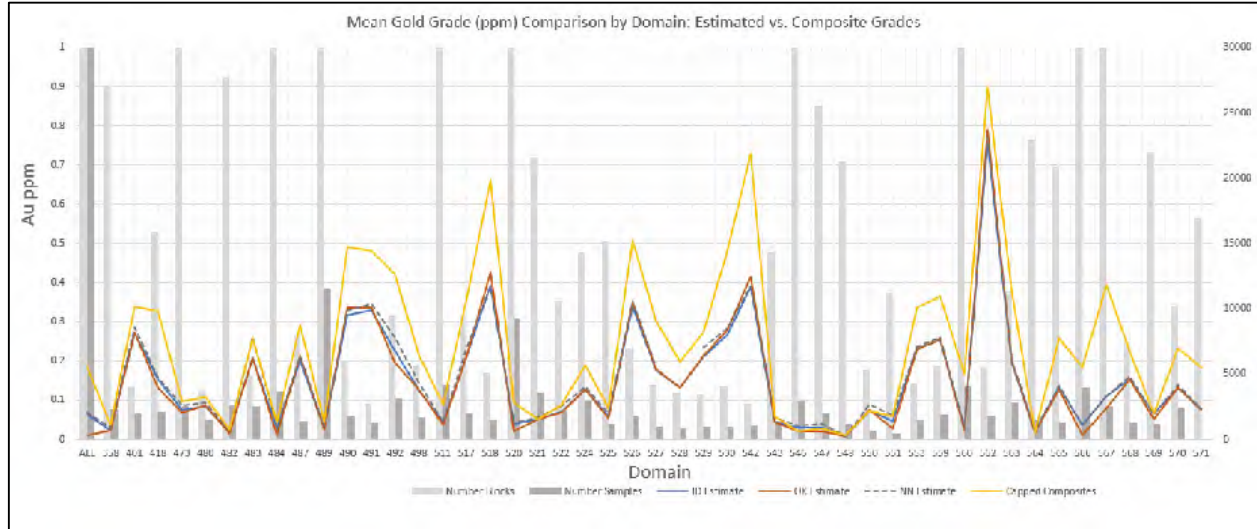


**Figure 11-9: Section C-C' - Visual Validation of Estimated Gold Grades, Gold Pick (McEwen, 2020)**

**11.11.2 Visual Validation and Comparative Statistics**

The model was validated visually in plan and section comparing drill hole composites to adjacent block grades. The interpolated OK and IDW gold grades were compared to both the underlying composite grades, as well as the corresponding NN grades to ensure that the final grades estimates were valid. When comparing the OK and IDW estimate to the composite grades, it is important that the final average estimated grade be lower than the composite grades to ensure that metal is not “manufactured” during estimation. Inclusion of the NN grades computed from 20’ composites is an additional check on the interpolated grades. To ensure that these grade relationships were honored during the grade estimation process. Overall, the three estimation methods fit well for each domain when the mean

grades are plotted for each domain as shown in Figure 11-10. Globally, the NN and IDW models fit best. On the domain scale all three methods fit well. Since the interpolations are not constrained by a grade shell this is expected. There is a higher variance in certain domains between the OK model and NN or IDW because the variogram parameters used give the majority of the sample weighting to the nearest samples determined by the dynamic anisotropic search directions.



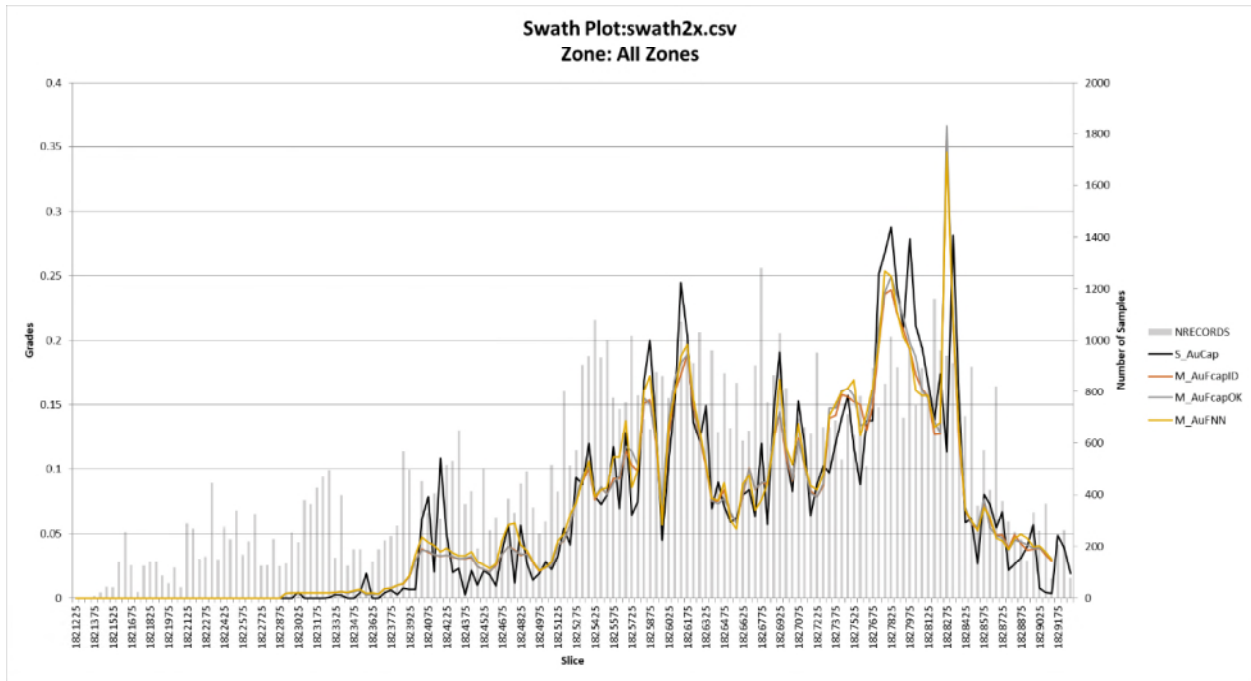
**Figure 11-10: Histogram of Estimated vs. Composite Au Grades by Domain (McEwen, 2020)**

### 11.11.3 Swath Plots

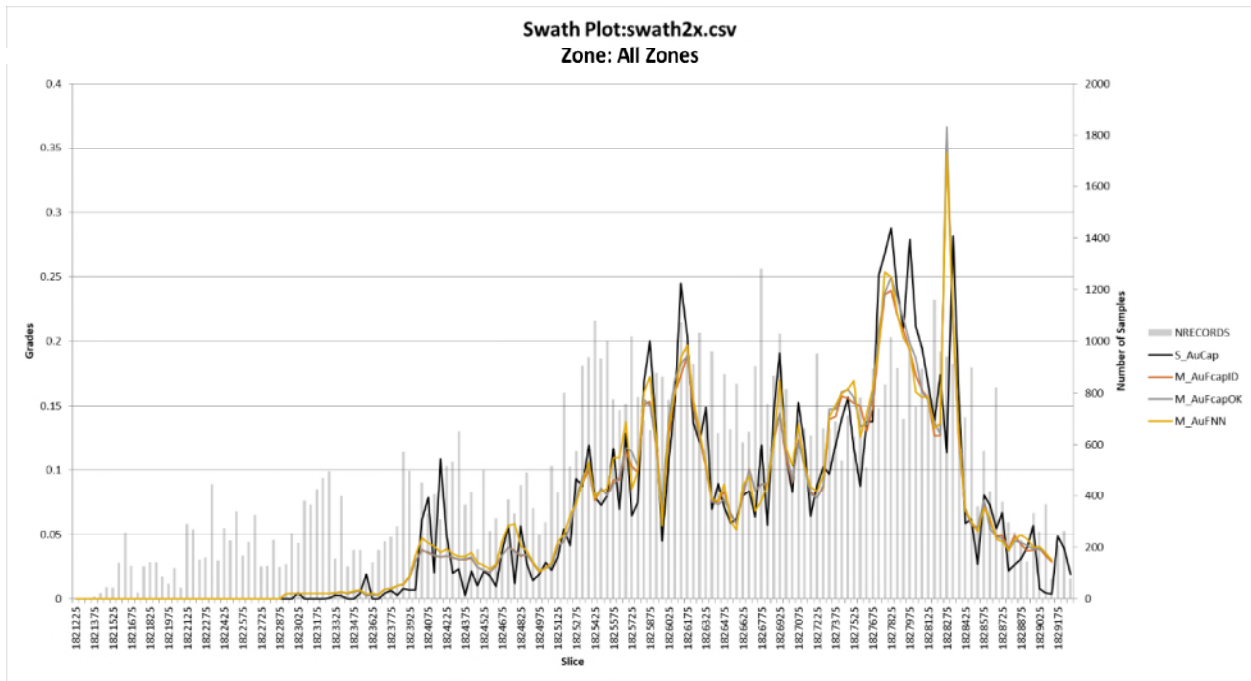
A swath plot is a graphical display of the grade distribution derived from a series of bands, or swaths, generated in several directions through the deposit. They are used to locate spatial grade disparity in the model. Using the swath plot, grade variations from the OK, IDW and NN models are compared to the distribution derived from the declustered composite dataset.

The grade trends may show local fluctuations on a swath plot, but the overall trend of the interpolated grades should be similar to the declustered composites. Swath plots were generated for gold grades along east-west and north-south directions, and also by elevation for the global model and individual domains. Swath widths were 50 ft wide for calculating east-west, north-south and elevation plots, respectively. Items plotted include Au grades by OK, IDW and NN for all estimated blocks as well as the corresponding declustered composites Au grades. The swath plots are shown in Figure 11-11 through Figure 11-13.

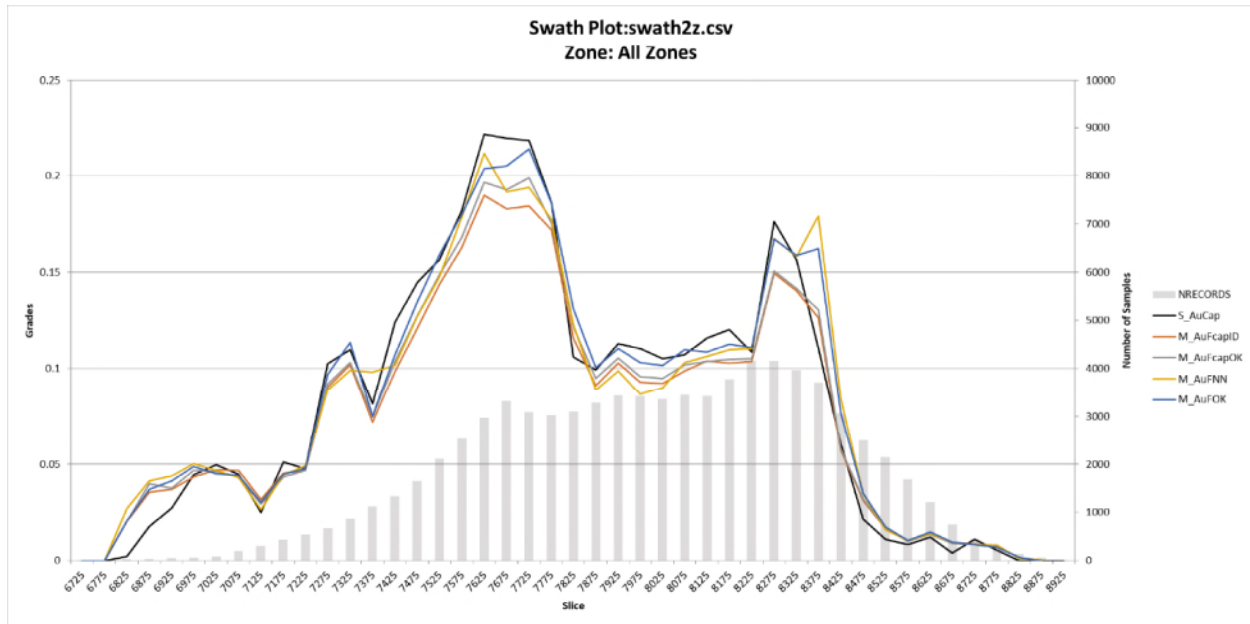
According to the swath plots, there is good correlation between the modeling methods with the composites used. While there is a certain amount of smoothing that occurs around the peaks and valleys and in areas with lower block counts, overall, the models fit well with the composite dataset.



**Figure 11-11: North-South Au Swath Plot - 120 ft Eastings (McEwen, 2020)**



**Figure 11-12: East-West Au Swath Plot - 120 ft Northings (McEwen, 2020)**

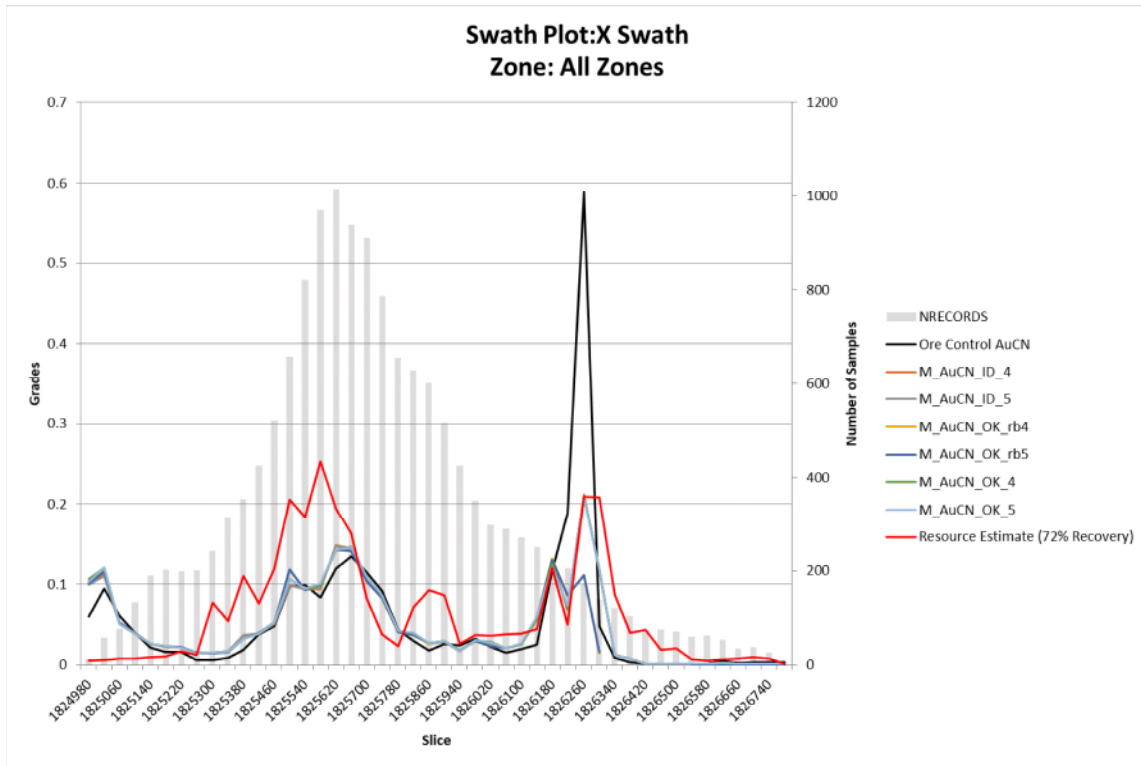


**Figure 11-13: Elevation Au Swath Plot - 80 ft Elevations (McEwen, 2020)**

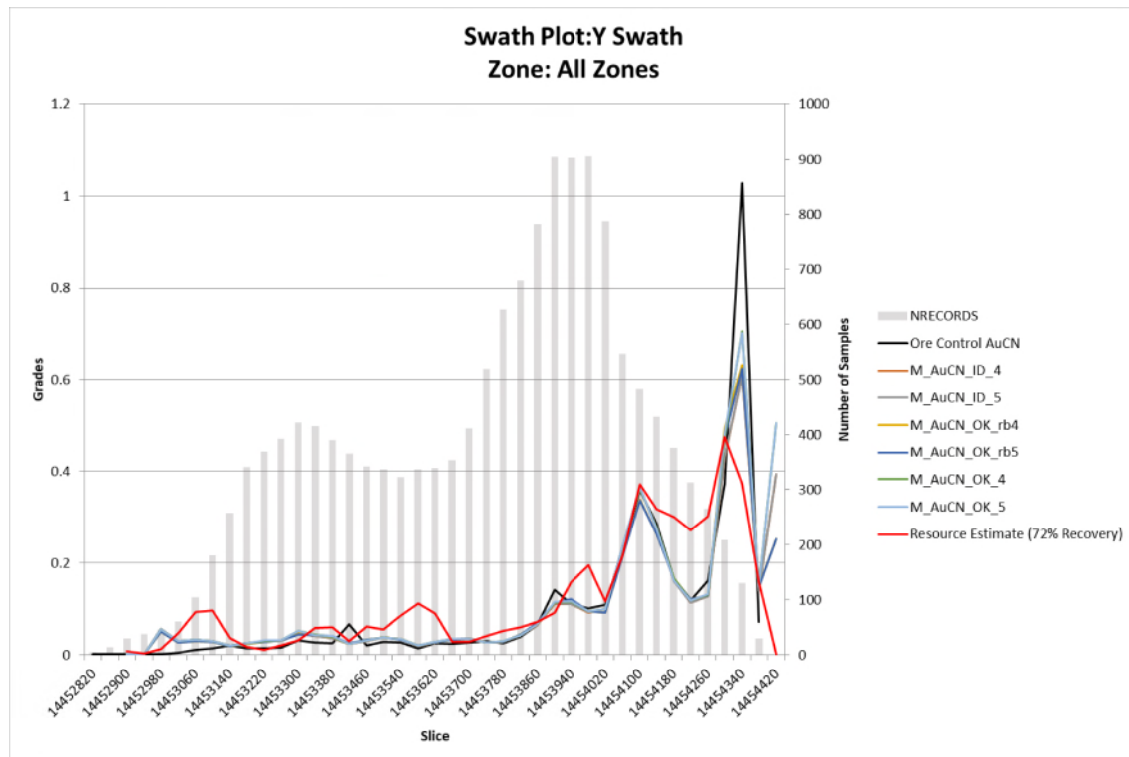
#### 11.11.4 Reconciliation to Available Ore Control Data

A review of the resource estimate versus available ore control data was completed. A comparison between interpolated blocks based on available cyanide assay ore control results vs. the resource estimate calculated with fire assay results is difficult when the effect of clays and deleterious minerals are factored into the difference between the assay methods.

Ore control AuCN results were spread by domains and variography completed to determine search parameters. Multiple models using ID<sup>2</sup>, ID<sup>3</sup>, and OK interpolation methods were used on 20x20x20 and 10x10x10 blocks to determine a best fit model for ore control data. Search parameters for number of samples used was varied and only one search pass was completed. Results for all models are similar. The smaller 10x10x10 blocks produced lower grades and lower tons above a cut-off grade of 0.005 opt Au. Selected models were compared using swath plots shown in Figure 11-14 through Figure 11-16 to the resource estimate. To correct the resource estimates based on Au fire assays to AuCn ore control results, a 72% recovery factor is applied to the estimated mineral resource.

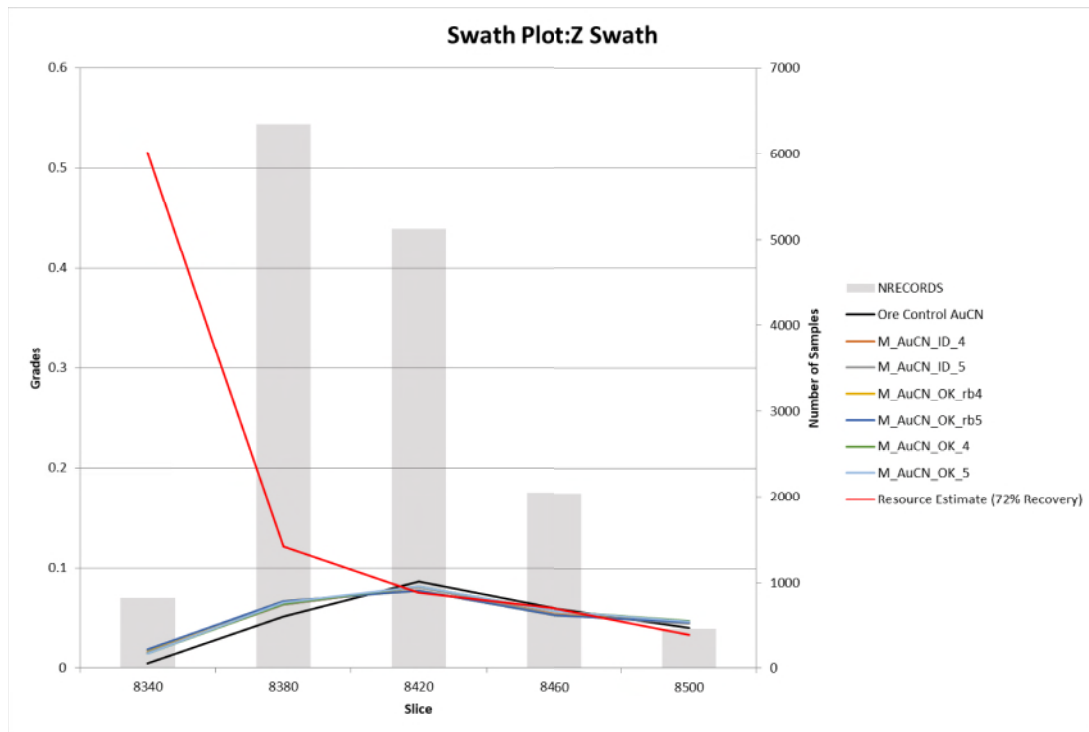


**Figure 11-14: East-West Reconciliation Au Swath Plot (McEwen, 2020)**



**Figure 11-15: North -South Reconciliation Au Swath Plot (McEwen, 2020)**





**Figure 11-16: Bench Reconciliation Au Swath Plot (McEwen, 2020)**

## 11.12 GOLD PICK ECONOMIC INPUT PARAMETERS

Cut-off grade for the Mineral Resource Statement was determined based on the following equation:

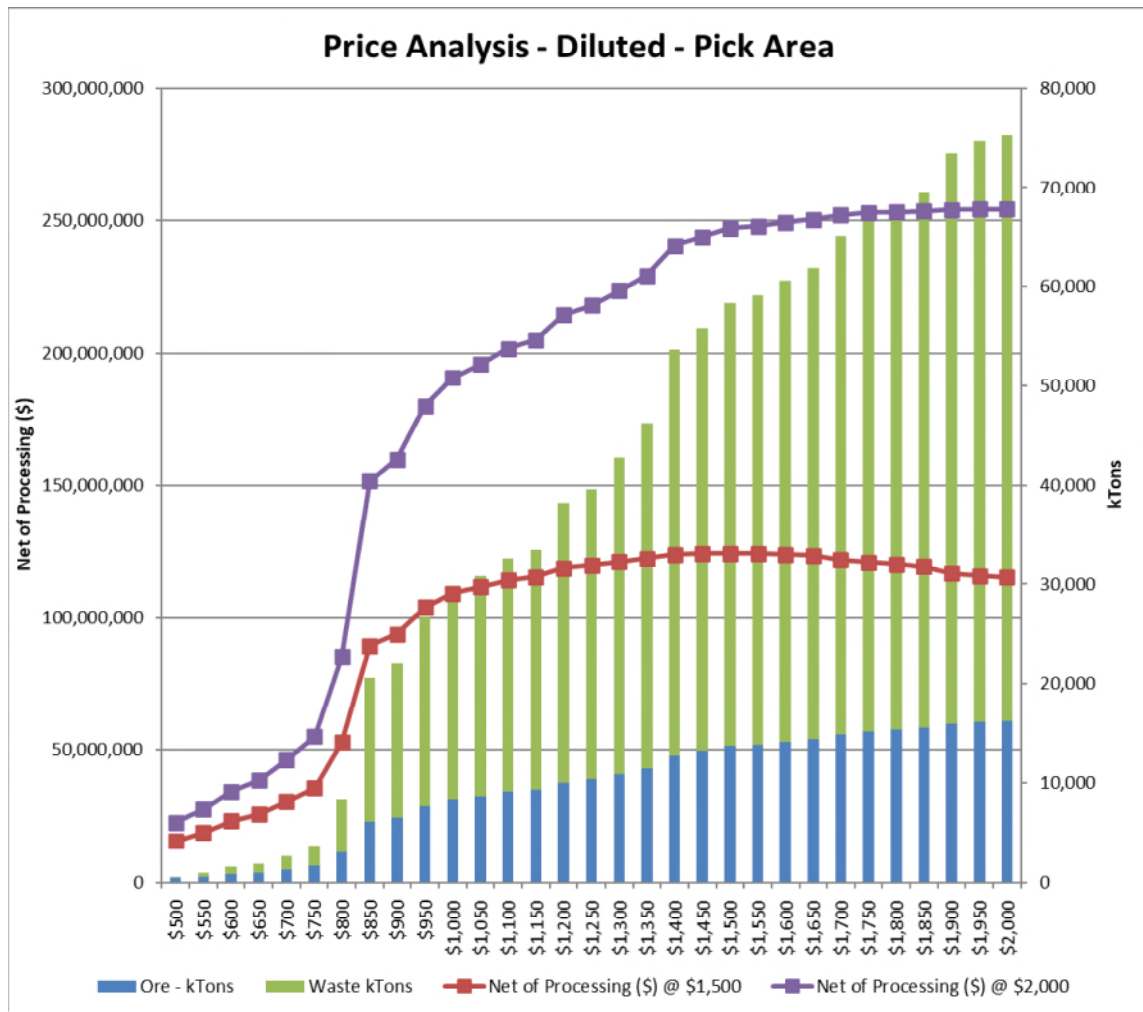
$$\text{Cut-off} = \frac{((1+\text{DIL}) * (\text{MCo} + \text{PC} + \text{SR} + \text{R}))}{(\text{Price} * \text{Rec} * \text{Factor})}$$

- DIL = Dilution: 0 for the resource
- MCo = Mining Cost: US\$3.19/t for ore, US\$1.99/t for waste
- PC = Total Ore Processing Cost: US\$8.13/t (combined ROM and stacked ore)
- Price = Net Gold Sales Price: US\$1,725/oz
- Rec = Recovery: 72% ROM oxide, 78% crushed oxide, and 50% mid-carbon
- SR=Smelting and Refining: \$2.013/oz
- R=Royalty: 0% for Gold Pick
- Factor = Factor for unit conversion: 1

The resulting cut-off grade for Gold Pick rounds to 0.007 oz/t Au.

## 11.13 GOLD PICK RESOURCE SENSITIVITY

The Gold Bar Mineral Resource is reported below at variable prices within the November 2020 Resource Pit to demonstrate the sensitivity of the mineral resource. The sensitivity analysis was completed using \$1,500/oz Au price and \$2,000/oz Au price. These sensitivities are provided in Figure 11-17 for diluted resource.



Source: IMC, 2020

**Figure 11-17: Gold Pick Sensitivity within the Gold Pick 2020 Resource Pit**

#### 11.14 GOLD RIDGE ASSAY DATA POPULATION DOMAIN ANALYSIS AND CAPPING

The Gold Ridge drilled assay database used in this study consisted of 424 drill holes and approximately 49,000 gold assay intervals. The cut-off date for new data used in this resource estimate was October 14, 2020.

Most of the drilling supporting the resource estimate was performed using RC methods with minimal core drilling (< 2%). However, when core drilling has been used, as described in Section 9.1 of this report, correlations are adequate to good, providing sufficient confidence for application of the data in resource modeling. RC drilling for all of Gold Bar has been above the water table; therefore, there are no issues related to drilling wet RC holes in the database.

Using lognormal probability plots and quantile analysis as guides, in conjunction with an examination of the distribution of drill hole data, metal removed, and effect on coefficient of variance, capping thresholds were selected for each interpolation domain for Gold Ridge. An inflection point on each probability plot was selected to identify assays that are to be considered “outliers” to the general distribution and then compared to other parameters and adjusted as necessary to achieve the best fit. Assays were “capped” or set back to the defined threshold. The thresholds identified are tabulated below in Table 11-8.

**Table 11-8: Gold Ridge Assay Capping Statistics by Interpolation Domain (McEwen, 2020),**

| <b>ZONE</b> | <b>No. Samples Capped</b> | <b>Au Cap (ppm)</b> |
|-------------|---------------------------|---------------------|
| 189         | 1                         | 0.04                |
| 197         | 7                         | 0.35                |
| 198         | 6                         | 2.66                |
| 208         | 9                         | 1.14                |
| 210         | 7                         | 4.73                |
| 212         | 4                         | 5                   |
| 214         | 11                        | 0.76                |
| 215         | 5                         | 2.4                 |
| 216         | 4                         | 0.42                |
| 217         | 6                         | 0.94                |
| 220         | 11                        | 1.76                |
| 221         | 3                         | 0.91                |
| 222         | 6                         | 5.33                |
| 224         | 7                         | 0.46                |
| 228         | 10                        | 2.8                 |
| 229         | 5                         | 0.4                 |
| 231         | 10                        | 1.07                |
| 237         | 3                         | 1.32                |
| 243         | 3                         | 0.02                |
| 245         | 11                        | 1.31                |
| 247         | 11                        | 1.79                |
| 249         | 3                         | 1.31                |
| 301         | 6                         | 0.33                |
| 311         | 4                         | 0.29                |
| 321         | 12                        | 0.35                |
| 346         | 21                        | 0.66                |
| 601         | 6                         | 4.27                |
| 611         | 12                        | 5.39                |
| 621         | 16                        | 7.38                |
| 631         | 16                        | 3.12                |
| 641         | 14                        | 2.77                |
| 651         | 4                         | 1.78                |

**11.15 GOLD RIDGE COMPOSITING**

After capping, the Au sample grades were composited to 10-ft fixed length intervals. After compositing, the composites were coded with the domain code. Table 11-9 summarizes the composite statistics.

**Table 11-9: Composite Statistics, Gold Ridge (McEwen, 2020)**

| Domain | No. Intervals | Minimum | Maximum | Mean  | Standard deviation | CV    | % Reduction applied to CV by Capping and Compositing |
|--------|---------------|---------|---------|-------|--------------------|-------|--|
| 189    | 19            | 0.003   | 0.066   | 0.012 | 0.016              | 1.405 | 37%  |
| 197    | 219           | 0.002   | 0.35    | 0.02  | 0.053              | 2.625 | 32%  |
| 198    | 199           | 0.001   | 2.547   | 0.448 | 0.563              | 1.257 | 12%  |
| 208    | 101           | 0.001   | 1.14    | 0.108 | 0.26               | 2.405 | 23%  |
| 210    | 371           | 0.001   | 4.73    | 0.41  | 0.782              | 1.904 | 9%   |
| 212    | 326           | 0.001   | 5       | 0.696 | 1.011              | 1.453 | 10%  |
| 214    | 294           | 0.001   | 0.76    | 0.061 | 0.138              | 2.252 | 28%  |
| 215    | 313           | 0.001   | 2.4     | 0.082 | 0.302              | 3.677 | 17%  |
| 216    | 37            | 0.003   | 0.442   | 0.061 | 0.103              | 1.695 | 8%   |
| 217    | 275           | 0.003   | 0.94    | 0.069 | 0.131              | 1.902 | 43%  |
| 220    | 647           | 0.001   | 1.76    | 0.075 | 0.213              | 2.854 | 18%  |
| 221    | 17            | 0.003   | 0.901   | 0.174 | 0.278              | 1.596 | 20%  |
| 222    | 375           | 0.003   | 5.33    | 0.428 | 0.694              | 1.621 | 16%  |
| 224    | 170           | 0.001   | 0.46    | 0.052 | 0.093              | 1.778 | 63%  |
| 228    | 239           | 0.001   | 2.8     | 0.441 | 0.654              | 1.483 | 12%  |
| 229    | 159           | 0.001   | 1.76    | 0.057 | 0.17               | 3     | 36%  |
| 231    | 251           | 0.002   | 1.07    | 0.105 | 0.209              | 1.997 | 20%  |
| 237    | 31            | 0.001   | 0.941   | 0.126 | 0.255              | 2.024 | 42%  |
| 243    | 3             | 0.004   | 0.017   | 0.011 | 0.007              | 0.625 | 14%  |
| 245    | 399           | 0.001   | 1.646   | 0.112 | 0.236              | 2.107 | 35%  |
| 247    | 250           | 0.002   | 1.79    | 0.169 | 0.339              | 2.006 | 23%  |
| 249    | 48            | 0.002   | 1.035   | 0.348 | 0.323              | 0.927 | 24%  |
| 301    | 1445          | 0.001   | 0.495   | 0.01  | 0.03               | 2.924 | 19%  |
| 311    | 209           | 0.001   | 0.443   | 0.031 | 0.054              | 1.744 | 20%  |
| 321    | 558           | 0.001   | 4.305   | 0.042 | 0.251              | 5.971 | 11%  |
| 346    | 1874          | 0.001   | 2.537   | 0.041 | 0.118              | 2.909 | 12%  |
| 601    | 3146          | 0.001   | 4.015   | 0.065 | 0.269              | 4.168 | 19%  |
| 611    | 324           | 0.001   | 5.39    | 0.441 | 0.983              | 2.227 | 23%  |
| 621    | 498           | 0.002   | 7.38    | 0.691 | 1.281              | 1.852 | 16%  |
| 631    | 485           | 0.001   | 3.12    | 0.264 | 0.565              | 2.137 | 11%  |
| 641    | 1243          | 0.001   | 2.77    | 0.059 | 0.277              | 4.68  | 9%   |
| 651    | 104           | 0.001   | 1.78    | 0.126 | 0.305              | 2.418 | 11%  |

### **11.16 GOLD RIDGE GEOMETALLURGICAL MODELING**

Areas of material characterized by potential reduced or refractory recovery were identified and modeled by incorporating additional aspects such as:

- Carbon intensity indicator; 0 or 2
- Sulfide; no measured sulfide was observed
- Cn/FA assay ratios; available for northern end of the deposit only

A risk variable was then assigned to the block model based on the criteria summarized in Table 11-4. Economic parameters were then assigned based on the risk assessment.

Silicification was also reviewed for Gold Ridge and modeled using the logged intensity codes 1,2 and 3. Pods of silicification exist along the fault zones where they intersect the Lone Mountain Formation (Dslm) contact and appear poddy in nature. Silicification has not been applied to the Gold Ridge recovery model.

Small carbon pods were identified in fault hanging walls from geologic logging. Carbon was modeled as an indicator isoshell with fault trends applied in Leapfrog Geo v5.1 and the block model was populated from the resulting isoshell.

CN/FA ratios were then used to populate the block model in areas where carbon and sulfide data is not available. The recovery model was created using the same interpolation methodology as the gold resource estimate. The results of the model were then used to populate the risk code as shown in Table 11-4.

### **11.17 GOLD RIDGE HISTORIC MINING DUMPS**

To account for the fill material left in dumps from previous mining, wireframe solids were created and coded to the model using a 50% majority rule. A 'Fill' attribute was then coded from the solid and the fill code was copied into the final model Domain field. Fill blocks were excluded from insitu tons and grade calculations.

### **11.18 GOLD RIDGE DENSITY**

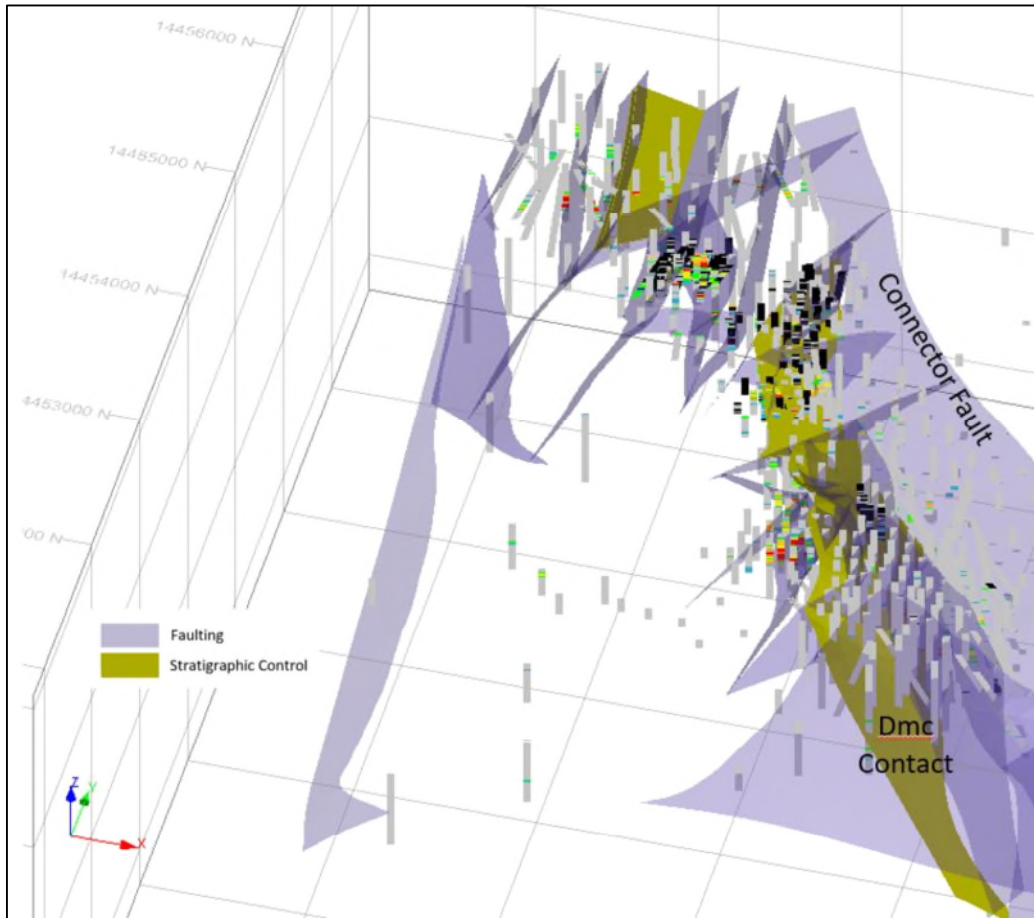
Density was assigned to the block model based on previous analyses outlined in the FS completed in 2018. A density value of 13.35 ft<sup>3</sup>/t was assigned to material with a grade >0.005 opt. The lower average density of the oxide mineralized material is a function of decalcification, argillization, and oxidation. Any blocks coded as fill were then assigned a tonnage factor of 16.7 ft<sup>3</sup>/t. A summary of Tonnage Factors by rock type is provided in Table 11-5.

Additional test work is being conducted in 2020-2021 to better assign density by lithology and alteration.

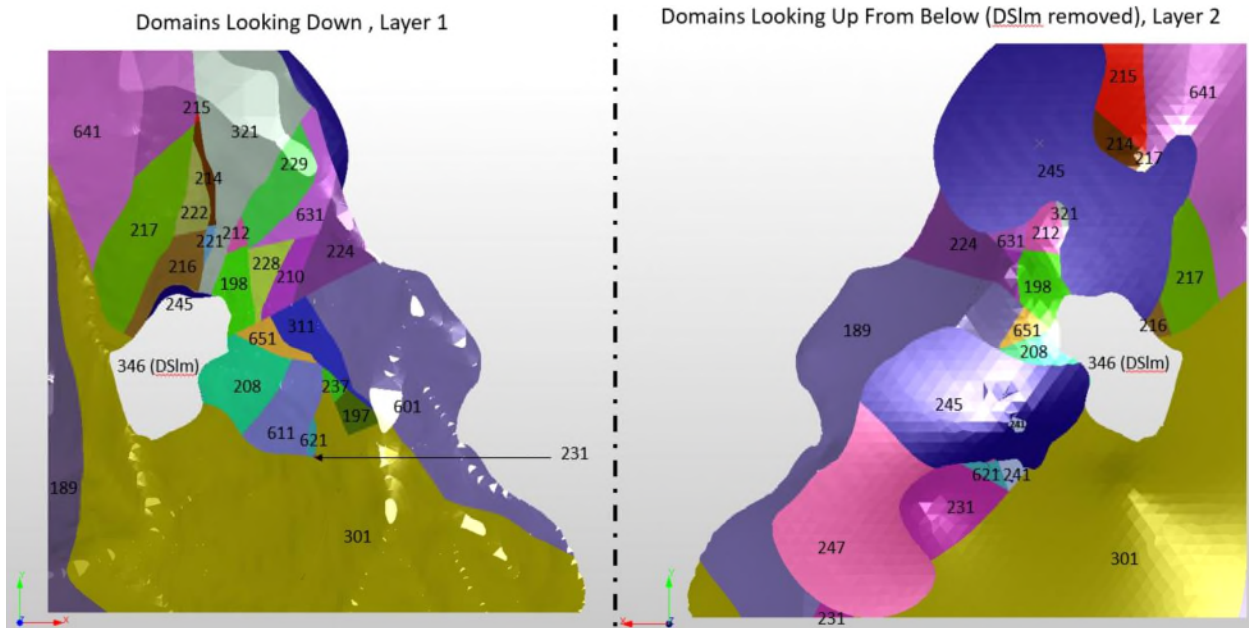
### **11.19 GOLD RIDGE VARIOGRAPHY AND INTERPOLATION SEARCH CRITERIA**

The purpose of the domains is to divide the data into meaningful pods within the Bartine (Dmb) and Coils (Dmc) stratigraphic units offset by faulting as illustrated in Figure 11-18. Domains shown in Figure 11-19 were created from this combination of fault offsets and stratigraphic boundaries. Faults/fracture sets shown in Figure 11-18 are divided into four broad trend directions. An ENE-trending, near-vertical, high-density fracture set which plays a role in mineralization and is offset by all other faults. The NE-trending fault set that predominately offsets mineralization with localized mineralization. The NS-trending, west-dipping fault set that plays a significant role in mineralization with numerous high-grade intersections on modeled fault surfaces. The NW-trending, west-dipping fault set, the youngest, offsets all previously mentioned fault sets, and plays a significant role in mineralization with numerous high-grade intersections on modeled fault surfaces.

Mineralization is almost entirely contained within the Bartine member of the McColley Canyon Formation with local occurrences of gold in the overlying Coils Creek member. Mineralization also locally extends into the underlying Kobeh (Dmk) member where silicification is observed in contact with the underlying Lone Mountain Formation.



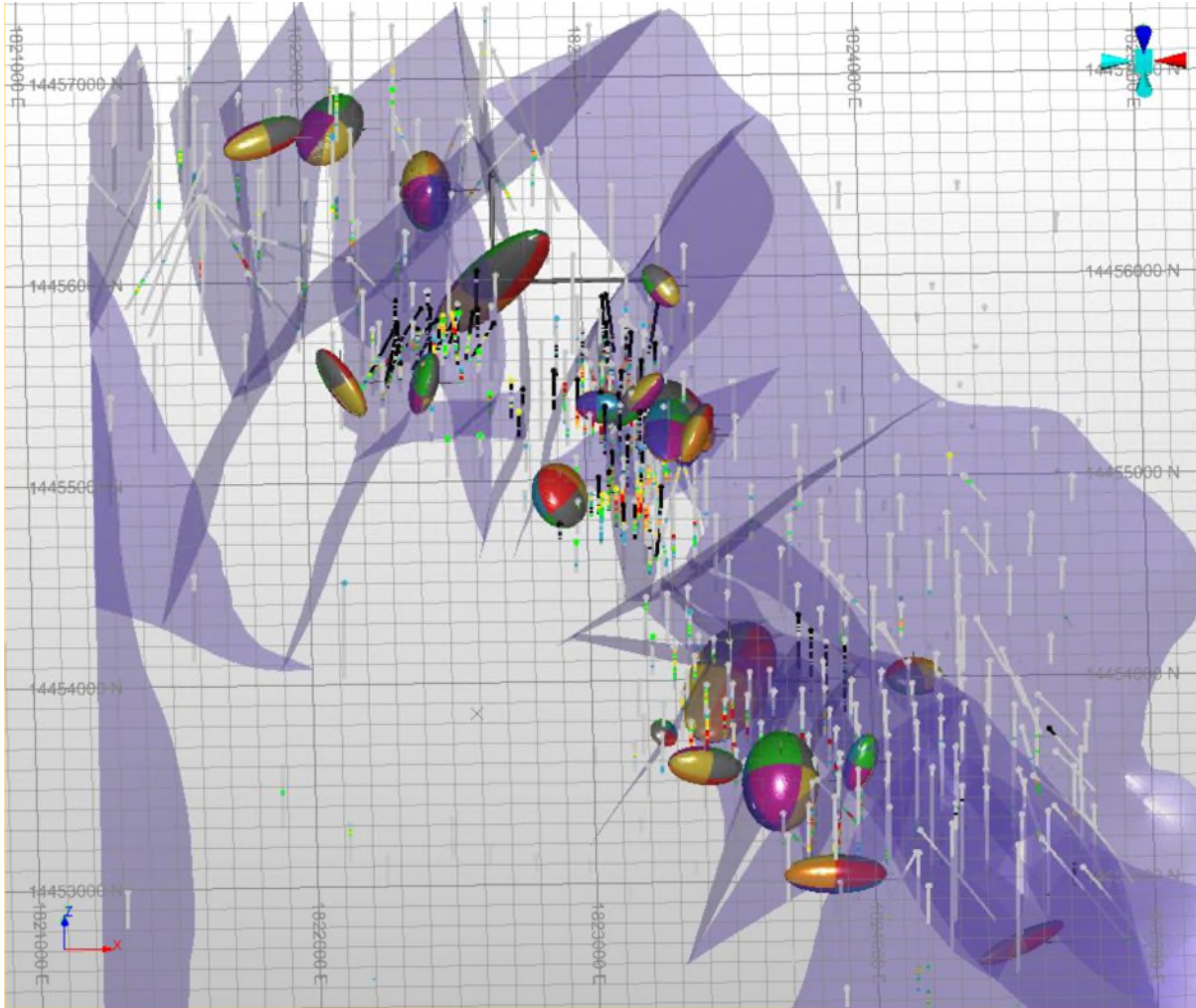
**Figure 11-18: Structural Model for Gold Ridge Deposit (McEwen, 2020)**



**Figure 11-19: Domains and Codes for the Gold Ridge Deposit (McEwen, 2020)**

Variograms were constructed for the composited and capped assay values independently for each interpolation domain. To facilitate this work McEwen used the Snowden Supervisor tool kit to develop a series of variograms, for each mineral domain.

The nugget value was determined from down hole variograms for each domain and then applied to the variogram models. Nugget values for Gold Ridge are low ranging between 0.005-0.2. The nugget and short-range structures tend to influence 70% of the total variogram model within an average of 130 feet for the domains. The search ellipsoids shown in Figure 11-20 generated from variography are typically oriented along the stratigraphic direction and mineralized fault trends. Search distances listed in Table 11-10 were initially set to 70% of the distance to sill and then adjusted up or down based on review of multiple model runs. Search distances were adjusted to minimize spread of mineralization beyond what was believed to be reliable distances from composites.



**Figure 11-20: Gold Ridge Grade Estimation Search Ellipsoids and Structural Mapping, Gold Ridge (McEwen, 2020)**

**Table 11-10: Gold Ridge Model Search Parameters, Gold Ridge (McEwen, 2020)**

| Domains | Datamine Rotation |     | Search Distance |       |            | Variogram |                    |
|---------|-------------------|-----|-----------------|-------|------------|-----------|--------------------|
|         | z                 | x   | z               | Major | Semi-Major | Minor     | % Distance to Sill |
| 197     | 45                | 125 | 95              | 125   | 58         | 58        | 80                 |
| 198     | 100               | 50  | 15              | 125   | 122        | 85        | 70                 |
| 208     | -160              | 90  | 120             | 30    | 90         | 58        | 80                 |
| 210     | 120               | 15  | 170             | 130   | 50         | 120       | 70                 |
| 212     | 20                | 110 | 10              | 95    | 64         | 45        | 80                 |
| 214     | 170               | 115 | 105             | 285   | 145        | 70        | 70                 |
| 215     | 50                | 65  | 40              | 100   | 42         | 80        | 80                 |
| 217     | 155               | 40  | 75              | 125   | 35         | 70        | 80                 |
| 220     | 120               | 110 | 180             | 118   | 122        | 92        | 80                 |
| 221     | 95                | 105 | 105             | 120   | 100        | 48        | 80                 |



**GOLD BAR PROJECT**  
**FORM 43-101F1 TECHNICAL REPORT – FEASIBILITY STUDY**

| Domains | Datamine Rotation                      |     |      | Search Distance |            |       | Variogram          |
|---------|--|-----|------|-----------------|------------|-------|--------------------|
|         | z                                      | x   | z    | Major           | Semi-Major | Minor | % Distance to Sill |
| 222     | 95                                     | 105 | 105  | 120             | 100        | 48    | 80                 |
| 224     | 120                                    | 15  | 170  | 130             | 50         | 120   | 70                 |
| 228     | -125                                   | 170 | -40  | 172             | 87         | 55    | 70                 |
| 229     | 95                                     | 40  | 135  | 68              | 39         | 68    | 80                 |
| 231     | -170                                   | 80  | 170  | 190             | 70         | 38    | 80                 |
| 237     | 45                                     | 125 | 95   | 125             | 58         | 58    | 80                 |
| 245     | 120                                    | 5   | 170  | 150             | 85         | 42    | 70                 |
| 247     | 160                                    | 25  | 170  | 190             | 40         | 20    | 70-90              |
| 249     | -160                                   | 90  | 120  | 30              | 90         | 58    | 80                 |
| 601     | 55                                     | 150 | 100  | 102             | 67         | 67    | 80                 |
| 611     | 170                                    | 90  | -160 | 208             | 105        | 88    | 80                 |
| 621     | 80                                     | 120 | 160  | 150             | 120        | 140   | 70                 |
| 631     | 70                                     | 40  | -175 | 180             | 125        | 65    | 70                 |
| 641     | 155                                    | 95  | 90   | 77              | 74         | 74    | 80                 |
| 651     | -160                                   | 90  | 120  | 30              | 90         | 58    | 80                 |
| 189     | Waste Zones, Block Model Not Populated |     |      |                 |            |       |                    |
| 216     |  |     |      |                 |            |       |                    |
| 301     |  |     |      |                 |            |       |                    |
| 311     |  |     |      |                 |            |       |                    |
| 321     |  |     |      |                 |            |       |                    |
| 346     |  |     |      |                 |            |       |                    |

**11.20 GOLD RIDGE GRADE ESTIMATION**

With the sample set available, inverse distance cubed (ID<sup>3</sup>) and ordinary kriging (OK) interpolation methods were used to estimate blocks within each domain using search distances derived from variography. A nearest neighbor (NN) model was also created from 20-foot composites using the same search orientations and distances as the OK and ID<sup>3</sup> models for validation purposes.

To preserve grade relationship to source data and reduce smearing, a search neighborhood strategy with three search ellipse ranges was used. The first pass was limited to data very close to the block at approximately 60-70% of the variogram range. Subsequent second and third search passes were increased in size by 2x the original distance and 2.2 times the original search distance. The search distances were adjusted by domain until the McEwen QP was satisfied that the blocks estimated represented an appropriate volume given the density of the source data and distance from mapped structures. Block grades on subsequent search passes were not allowed to overwrite previous estimates.

For each interpolation run, hard and soft boundaries were applied to test domain boundaries that produced ambiguous results from boundary condition testing. Comparison of the final models to the NN model showed that the soft boundary models were lower in grade. This was due to the influence of lower grade material that typically occurs on one side of the boundary condition. The final model utilized hard boundaries for interpolation to help preserve grades along mineralized domain boundaries.

The ID3 model was chosen as the final model method after comparison to OK and NN models. Kriging appeared to overly smooth the domains in areas where mineralization was limited to narrow structural control while the ID model more heavily weighted the samples at short distances.

**11.21 GOLD RIDGE MINERAL RESOURCE CLASSIFICATION**

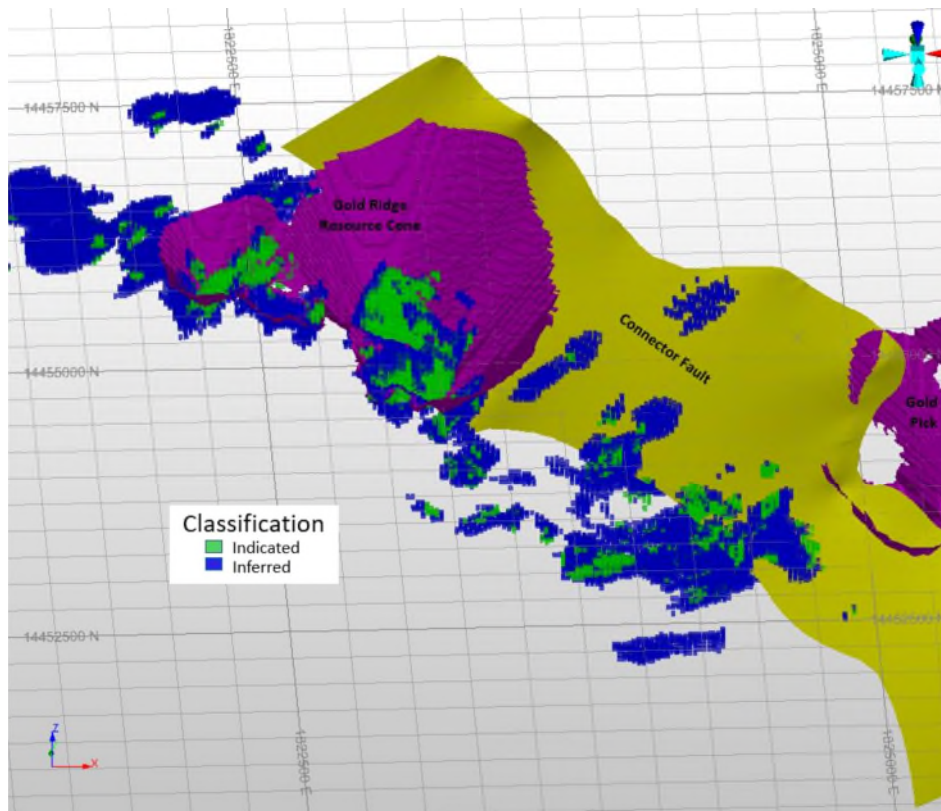
Mineral Resources were classified into Measured, Indicated, and Inferred categories based on CIM Definition Standards. Parameters used for classification are listed in Table 11-11. Parameters for measured are not included as those blocks were reclassified as indicated.

**Table 11-11: Gold Ridge Classification Parameters (McEwen, 2020)**

|                                      | Indicated | Inferred |
|--------------------------------------|-----------|----------|
| <b>Block Model Code</b>              | 2         | 3        |
| <b>Average Distance</b>              | ≤65       | ≤150     |
| <b>Minimum Number of Drill holes</b> | 3         | 2        |
| <b>Minimum Number of Samples</b>     | 5         | 3        |

Classification using a purely statistical approach occasionally produces artifacts—blocks that fail mathematical criteria but are clearly related to adjacent blocks. Again, Measured blocks were then reclassified as Indicated based on on-going work to determine density values and mineralogy that could potentially affect recovery.

An oblique view of model blocks with Au > 0.005 opt showing the distribution of Indicated (green) and Inferred (blue) categories is provide Figure 11-21.



**Figure 11-21: Gold Ridge Estimated Blocks Colored by Classification Code (McEwen, 2020)**

**11.22 GOLD RIDGE BLOCK MODEL VALIDATION**

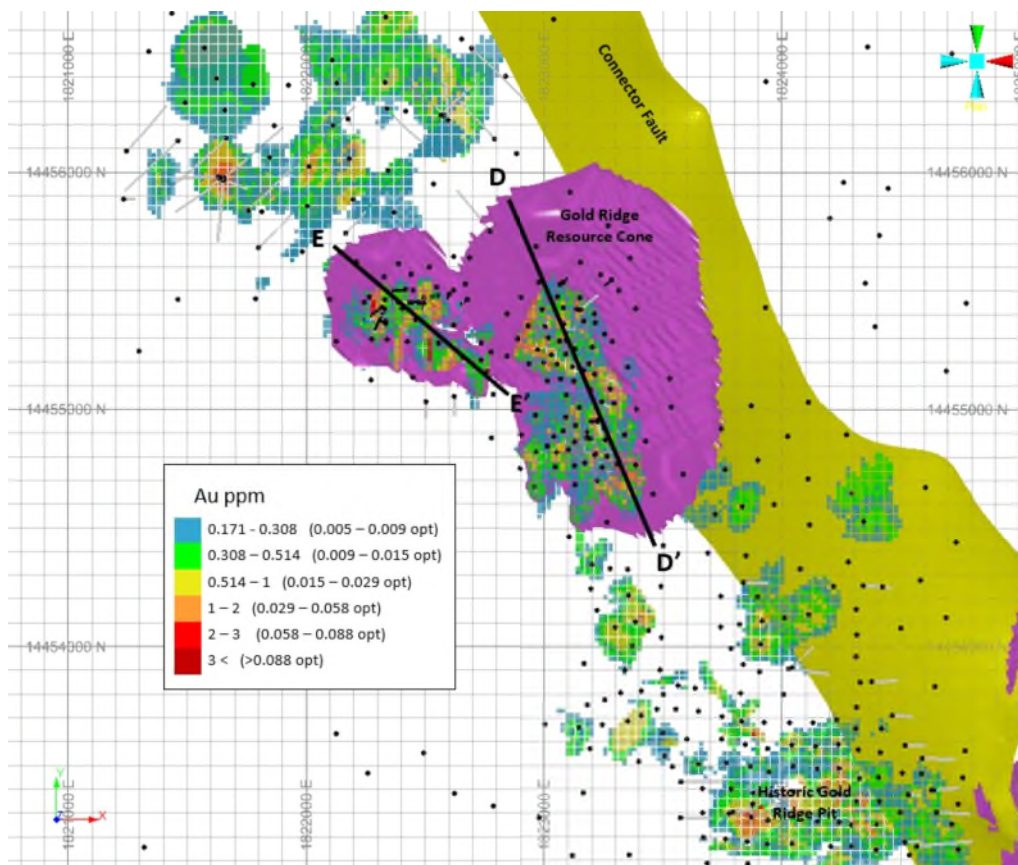
Various measures were implemented to validate the Gold Bar North block model. These measures included the following:

- Comparison of drill hole composites with resource block grade estimates from all zones visually in plan and section view;
- Statistical comparisons between block and composite data using distribution analysis;
- Statistical comparisons between the IDW, OK and NN models; and
- Swath plot analysis (drift analysis) comparing the inverse distance model with the NN model and declustered composite grades.

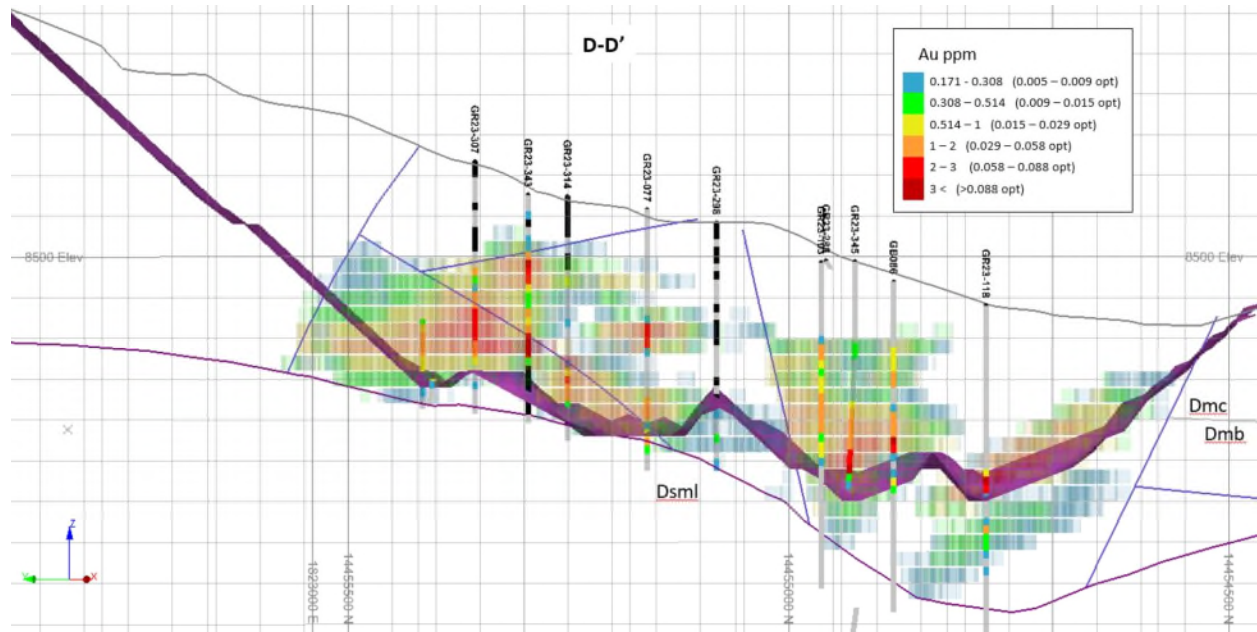
**11.22.1 Visual Comparison**

The model was validated visually in plan and section views comparing drill hole composites to adjacent block grades.

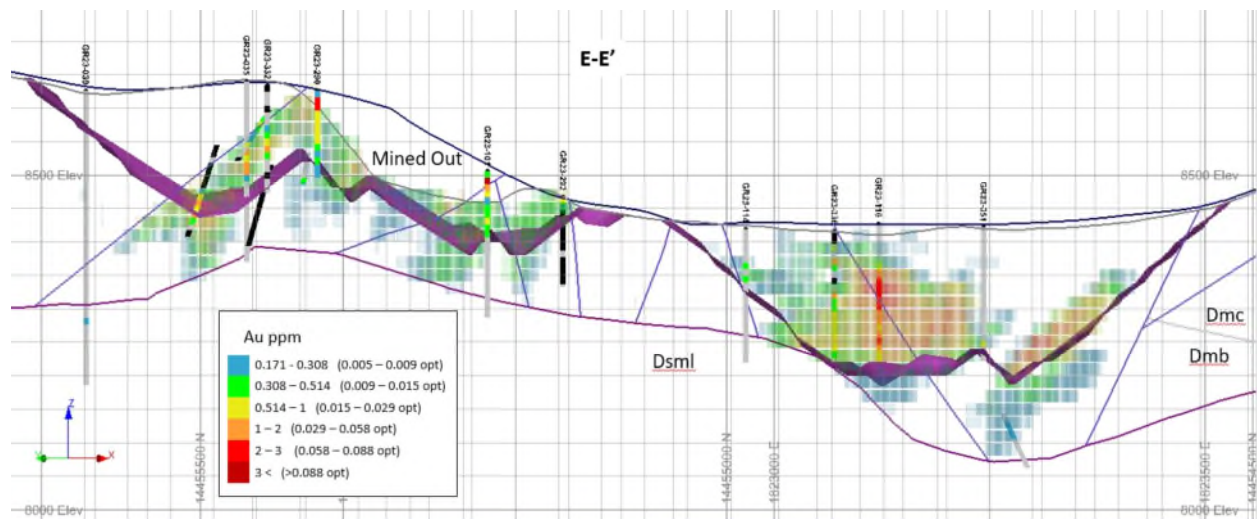
The estimated values of resource model block grades visually compare satisfactorily with composite values. Figure 11-22 provides a plan view of the resource pit and defines the locations of the cross sections. Figure 11-23 and Figure 11-24 provide cross sections showing the blocks colored by the IDW estimated Au oz/t values and the corresponding composite grades for drill hole intervals within 40 ft of the cross section. The purple line represents the contact between the mineralized Bartine and the underlying Lone Mountain dolomite. Blue lines represent faults. The block model is clipped to the November, 2020 end of month topography. Purple ribbon represents the 2020 \$1750 resource cone.



**Figure 11-22: Plan View of Visual Validation Cross Section Locations for Estimated Grades, Gold Ridge (McEwen, 2020)**



**Figure 11-23: Section D-D' – Visual Validation of Estimated Gold Grades, Gold Ridge (McEwen, 2020)**

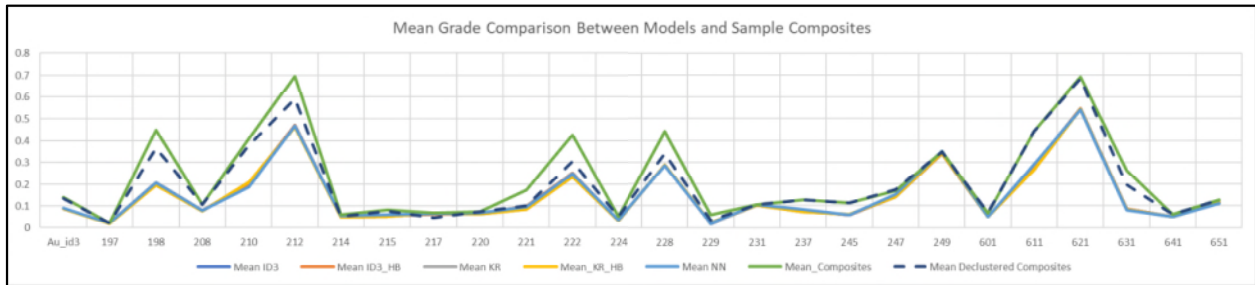


**Figure 11-24: Section E-E' – Visual Validation of Estimated Gold Grades, Gold Ridge (McEwen, 2020)**

### 11.22.2 Visual Validation and Comparative Statistics

The interpolated OK and IDW gold grades (hard boundary and soft boundary models) were compared to both the underlying composite grades and declustered composites as well as the corresponding NN grades to ensure that the final grades estimates were valid. When comparing the OK and IDW estimate to the composite grades, it is important that the final average estimated grade be lower than the composite grades to ensure that metal is not “manufactured” during estimation. Inclusion of the NN grades computed from 20’ composites is an additional check on the interpolated grades. To ensure that these grade relationships were honored during the grade estimation process. Overall, the three estimation methods fit well for each domain when the mean grades are plotted for each domain as shown in

Figure 11-25. Globally, the NN and IDW models fit best but on the domain scale all three methods fit well. Since the interpolations are not constrained by a grade shell this is expected.



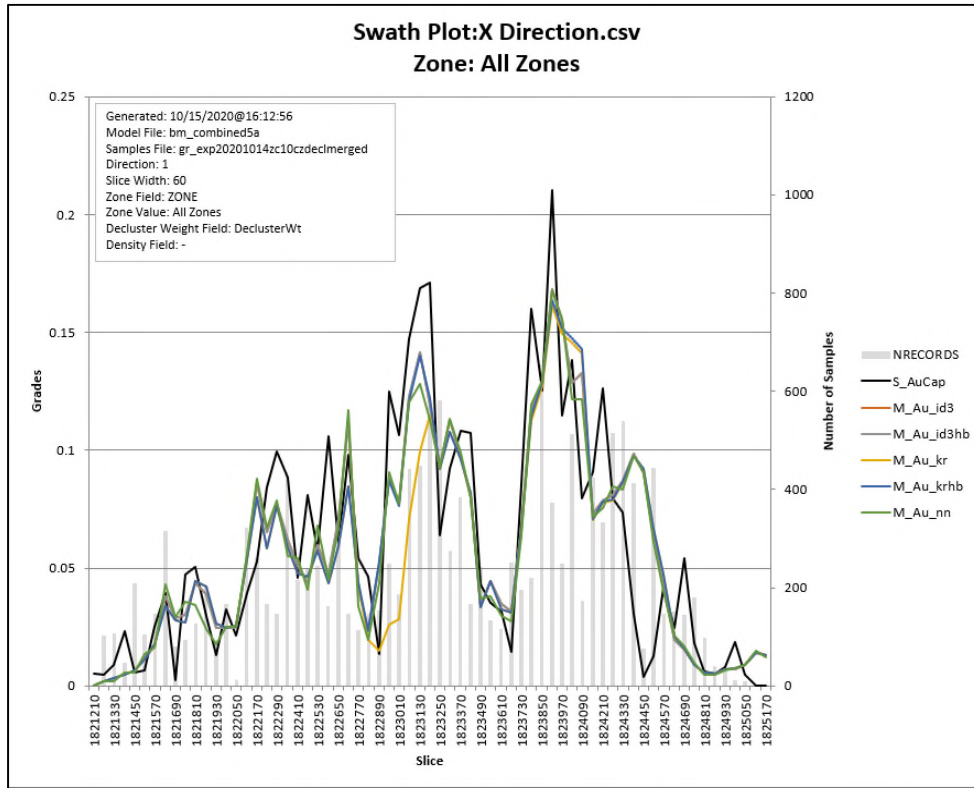
**Figure 11-25: Histogram of Estimated vs. Composite Au Grades, Gold Ridge (McEwen, 2020)**

### 11.22.3 Swath Plots

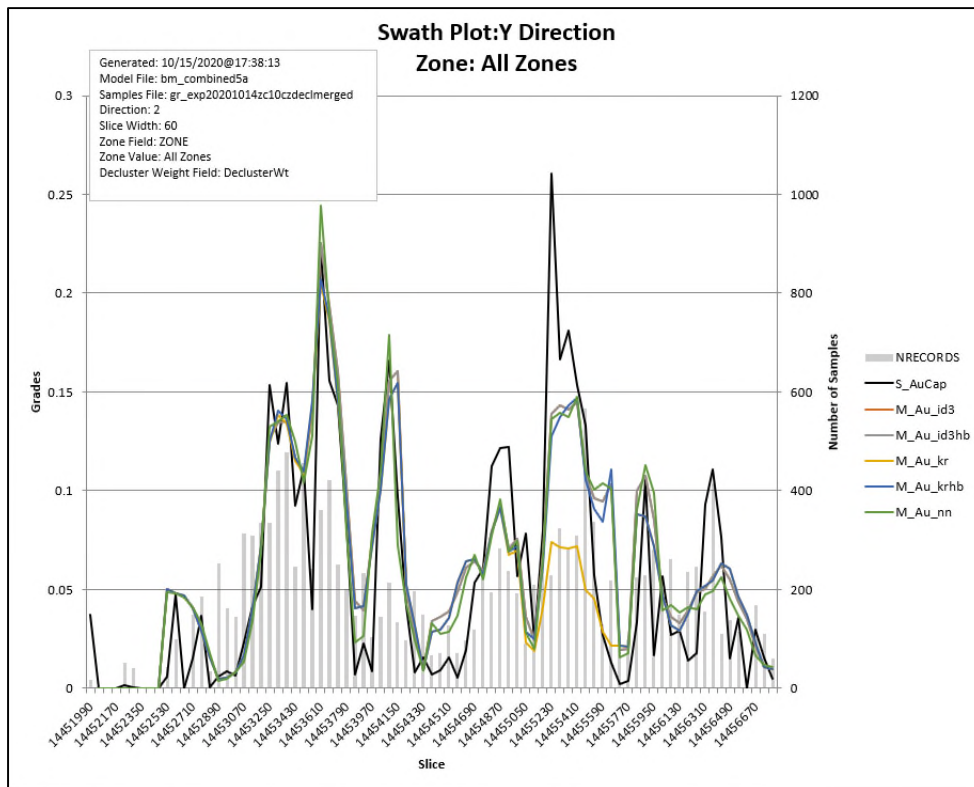
Using the swath plot, grade variations from the OK, IDW and NN models are compared to the distribution derived from the declustered composite dataset.

The grade trends may show local fluctuations on a swath plot, but the overall trend of the interpolated grades should be similar to the declustered composites. Swath plots were generated for gold grades along east-west and north-south directions, and also by elevation for the global model and individual domains. Swath widths were 60, 60, and 40 ft wide for east-west, north-south and elevation swaths, respectively. Items plotted include Au grades by OK, IDW (hard and soft boundary models) and NN for all estimated blocks as well as the corresponding declustered composites (capped prior to compositing) Au grades. The swath plots are shown in Figure 11-26 through Figure 11-28.

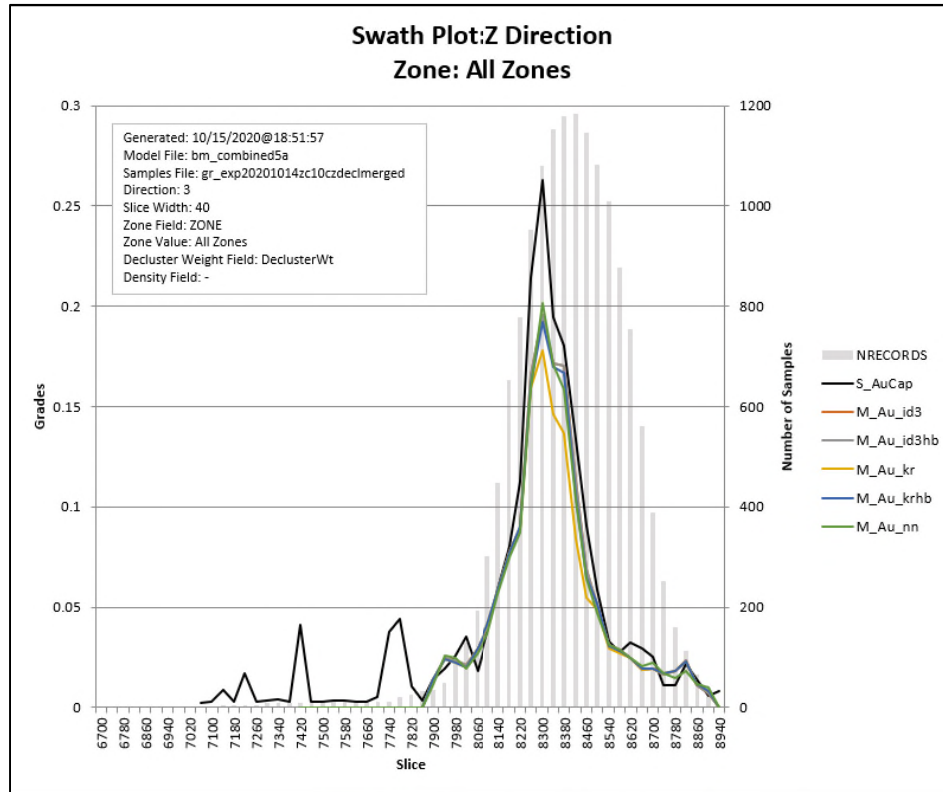
According to the swath plots, there is good correlation between the OK and ID methods utilizing hard boundaries and the NN method with the composites used. While there is a certain amount of smoothing that occurs around the peaks and valleys and in areas with lower block counts, overall, the models fit well with the composite dataset. The models interpolated using soft domain boundaries show more smoothing in the high- and low-grade ranges.



**Figure 11-26: North-South Au Swath Plot – 60 ft Eastings, Gold Ridge (McEwen, 2020)**



**Figure 11-27: East-West Au Swath Plot 60 ft Northings, Gold Ridge (McEwen, 2020)**



**Figure 11-28: Elevation Au Swath Plot – 40 ft Elevations, Gold Ridge (McEwen, 2020)**

**11.23 GOLD RIDGE ECONOMIC INPUT PARAMETERS**

Cut-off grade for the Mineral Resource Statement was determined based on the following equation:

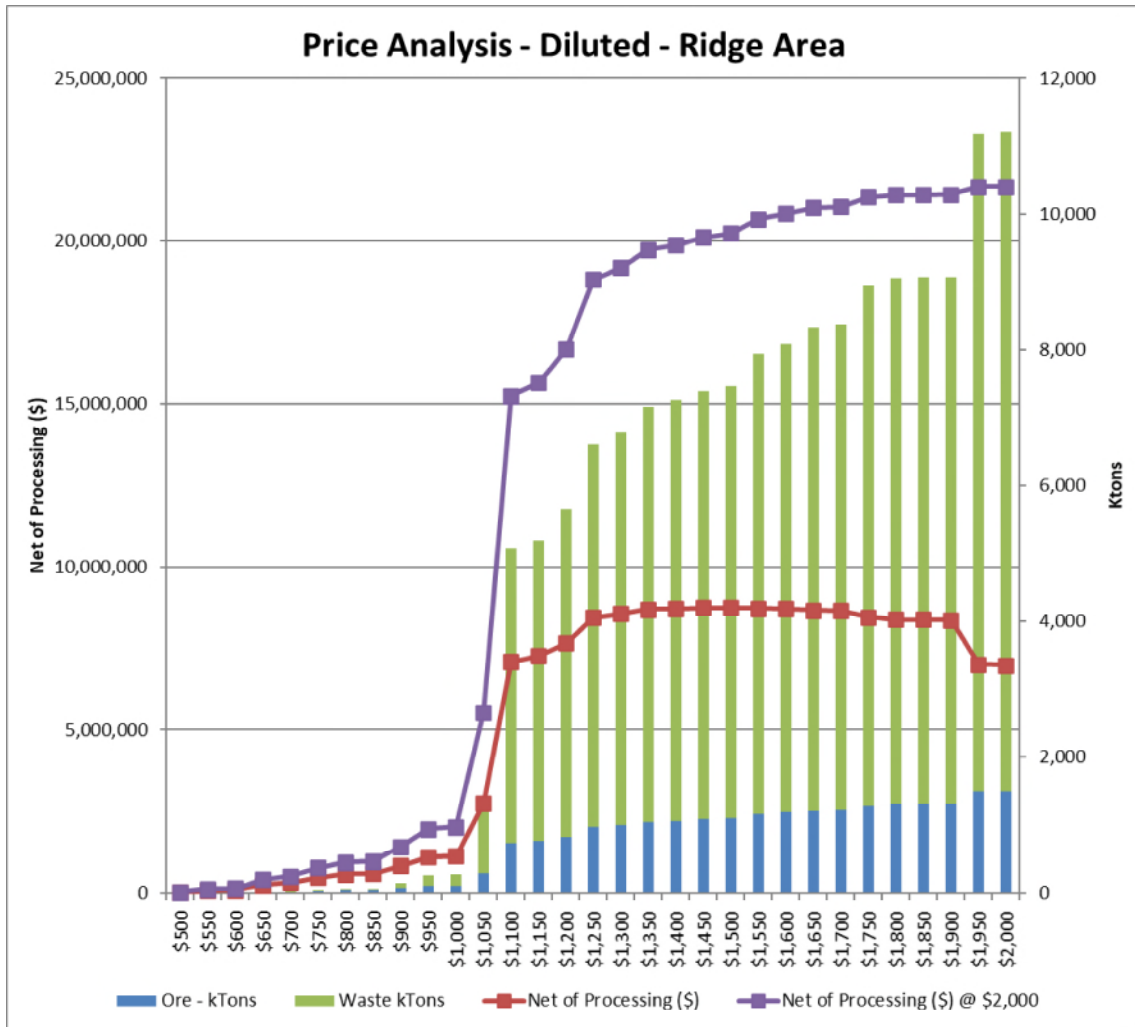
$$\text{Cut-off} = ((1+\text{DIL}) * (\text{MCo} + \text{PC} + \text{SR} + \text{R})) / (\text{Price} * \text{Rec} * \text{Factor})$$

- DIL = Dilution: 0 for the resource
- MCo = Mining Cost: US\$3.19/t for ore, US\$1.99/t for waste
- PC = Total Ore Processing Cost: US\$8.13/t (combined ROM and stacked ore)
- Price = Net Gold Sales Price: US\$1,725/oz
- Rec = Recovery: 72% oxide ROM, 78% oxide Crush, and 50% mid-carbon
- SR=Smelting and Refining: \$2.013/oz
- R=Royalty: 0% for Gold Ridge
- Factor = Factor for unit conversion: 1

The resulting cut-off grade for Gold Ridge rounds to 0.007 oz/t Au.

**11.24 GOLD RIDGE MINERAL RESOURCE SENSITIVITY**

The Gold Bar Mineral Resource is reported below at variable prices within the November 2020 Resource Pit to demonstrate the sensitivity of the resource. The sensitivity analysis was completed using \$1,500/oz Au price and \$2,000/oz Au price. These sensitivities are provided in Figure 11-29 for diluted resource.



**Figure 11-29: Gold Ridge Sensitivity Within the Resource Pit (McEwen, 2020)**

**11.25 CABIN ASSAY DATA POPULATION DOMAIN ANALYSIS AND CAPPING**

The Cabin assay database used in this study consisted of 193 drill holes and approximately 15,400 gold assay intervals. The cut-off date for data used in this resource estimate was September 29, 2020.

Most of the drilling supporting the resource estimate was performed using RC methods with minimal core drilling (~5%). However, when core drilling has been used, as described in Section 9.1 of this report, correlations are adequate to good, providing sufficient confidence for application of the data in resource modeling. RC drilling for all of Gold Bar has been above the water table; therefore, there are no issues related to drilling wet RC holes in the database.

Using probability plots and histograms as guides, capping thresholds were selected for each interpolation domain for Cabin. An inflection point on each probability plot was selected to identify assays that are to be considered “outliers” to the general distribution and then compared to percentile analysis break points Assays were “capped” or set back to the defined threshold. The thresholds identified are tabulated below in Table 11-12.



**Table 11-12: Cabin Assay Capping Statistics by Interpolation Domain (MTS, 2020)**

| Domain      |       | Au ppm Cap | No. Samples Capped | Domain      |            | Au ppm Cap | No. Samples Capped |
|-------------|-------|------------|--------------------|-------------|------------|------------|--------------------|
| Fault Block | Strat |            |                    | Fault Block | Strat      |            |                    |
| 1           | 700   | none       |                    | 26          | 700        | none       |                    |
| 2           | 700   | 2          | 4                  | 1           | 800        | 1          | 3                  |
| 3           | 700   | 1.3        | 5                  | 2           | 800        | none       | 0                  |
| 4           | 700   | 3          | 5                  | 3           | 800        | none       | 0                  |
| 6           | 700   | 0.7        | 6                  | 4           | 800        | 1.9        | 2                  |
| 7           | 700   | 0.1        | 2                  | 6           | 800        | 1.5        | 2                  |
| 8           | 700   | 2          | 6                  | 7           | 800        | 5          | 1                  |
| 9           | 700   | 6          | 5                  | 8           | 800        | 1          | 3                  |
| 10          | 700   | 7          | 9                  | 9           | 800        | 1          | 2                  |
| 11          | 700   | 3          | 4                  | 11          | 800        | none       | 0                  |
| 14          | 700   | 3          | 1                  | 16          | 800        | none       | 0                  |
| 15          | 700   | 5          | 6                  | 17          | 800        | none       | 0                  |
| 16          | 700   | 3.5        | 4                  | 18          | 800        | none       | 0                  |
| 17          | 700   | 1.2        | 2                  | 19          | 800        | none       | 0                  |
| 18          | 700   | 0.75       | 2                  | 20          | 800        | none       | 0                  |
| 19          | 700   | none       |                    | 21          | 800        | none       | 0                  |
| 20          | 700   | none       |                    | 22          | 800        | none       | 0                  |
| 21          | 700   | 2.9        | 1                  | 26          | 800        | 2          | 0                  |
| 22          | 700   | none       |                    | All         | Ddl (500)  | None       | 0                  |
| 24          | 700   | 3          | 1                  | All         | Dmc (600)  | None       | 0                  |
| 25          | 700   | 1.9        | 2                  | All         | DSIm (900) | None       | 0                  |

Metal at risk was investigated using the 20x20 model by comparing the uncapped grade estimate (AUOK) to the Capped grade estimate (AUOKC) for blocks classified as Indicated Mineral Resources and Inferred Mineral Resources. The metal at risk for the Dmb is 4.57%. The metal at risk for the Dmk is 2.4%. The amount of metal removed by capping is considered to be reasonable.

**11.26 CABIN COMPOSITING**

After capping, the Au sample grades were composited to 10 ft fixed length intervals. Table 11-13 summarizes the number of composites, mean grade and CV for each stratigraphic unit by fault block.

Table 11-13: Cabin Composite Statistics (MTS, 2020)

| Fault Block | Number Composites by Domain |      |      |      |      |      |       | Mean Grade Au ppm |      |      |      |      |      | CV   |      |      |      |      |      |      |
|-------------|-----------------------------|------|------|------|------|------|-------|-------------------|------|------|------|------|------|------|------|------|------|------|------|------|
|             | Tv                          | Ddl  | Dmc  | Dmb  | Dmk  | DSIm | Total | Fault Block       | Tv   | Ddl  | Dmc  | Dmb  | Dmk  | DSIm | Tv   | Ddl  | Dmc  | Dmb  | Dmk  | DSIm |
|             | -100                        | -500 | -600 | -700 | -800 | -900 |       |                   | -100 | -500 | -600 | -700 | -800 | -900 | -100 | -500 | -600 | -700 | -800 | -900 |
| 1           |                             |      |      | 33   | 41   | 133  | 207   | 1                 |      |      |      | 0.13 | 0.17 | 0.02 |      |      |      | 1.37 | 1.53 | 1.4  |
| 2           |                             |      |      | 62   | 4    | 4    | 70    | 2                 |      |      |      | 0.45 | 0.19 | 0.03 |      |      |      | 1.43 | 0.82 | 0.19 |
| 3           |                             |      | 2    | 573  | 44   | 16   | 635   | 3                 |      |      | 0    | 0.09 | 0.06 | 0.07 |      |      | 0    | 2.2  | 1.88 | 1.64 |
| 4           |                             |      |      | 562  | 219  | 68   | 849   | 4                 |      |      |      | 0.07 | 0.1  | 0.03 |      |      |      | 4.3  | 2.7  | 1.5  |
| 6           |                             | 32   | 76   | 293  |      |      | 401   | 6                 |      | 0.02 | 0.01 | 0.04 |      |      |      | 0.73 | 1.4  | 3.01 |      |      |
| 7           |                             |      |      | 61   | 138  | 82   | 281   | 7                 |      |      |      | 0.02 | 0.13 | 0.02 |      |      |      | 1.64 | 2.2  | 1.87 |
| 8           |                             |      |      | 244  | 107  | 11   | 362   | 8                 |      |      |      | 0.27 | 0.63 | 0.03 |      |      |      | 2.46 | 1.4  | 0.39 |
| 9           |                             |      |      | 281  | 104  | 72   | 457   | 9                 |      |      |      | 0.6  | 0.15 | 0.08 |      |      |      | 1.85 | 1.34 | 1.7  |
| 10          |                             |      |      | 186  |      |      | 186   | 10                |      |      |      | 0.39 |      |      |      |      |      | 3.73 |      |      |
| 11          |                             |      | 70   | 670  | 75   |      | 815   | 11                |      |      | 0    | 0.06 | 0.14 |      |      |      | 1.09 | 4.23 | 1.47 |      |
| 14          |                             |      | 19   | 330  |      |      | 349   | 14                |      |      | 0.01 | 0.21 |      |      |      |      | 0.98 | 1.94 |      |      |
| 15          |                             | 4    | 83   | 458  |      |      | 545   | 15                |      | 0.01 | 0.01 | 0.14 |      |      |      | 0.4  | 1.09 | 3.55 |      |      |
| 16          |                             |      |      | 131  | 16   | 13   | 160   | 16                |      |      |      | 0.49 | 0.18 | 0.03 |      |      |      | 1.74 | 1.39 | 1.95 |
| 17          | 21                          |      |      | 31   | 61   | 11   | 124   | 17                | 0.02 |      |      | 0.17 | 0.03 | 0.07 | 1.76 |      |      | 1.45 | 2.48 | 1.85 |
| 18          |                             |      |      | 181  | 55   | 15   | 251   | 18                |      |      |      | 0.05 | 0.08 | 0.03 |      |      |      | 1.86 | 1.33 | 0.5  |
| 19          |                             |      |      | 189  | 49   | 28   | 266   | 19                |      |      |      | 0.2  | 0.03 | 0.04 |      |      |      | 1.87 | 0.96 | 1.69 |
| 20          |                             |      |      | 14   | 8    | 7    | 29    | 20                |      |      |      | 0.01 | 0.01 | 0    |      |      |      | 1.23 | 1.17 | 0.53 |
| 21          |                             |      |      | 146  | 11   | 1    | 158   | 21                |      |      |      | 0.24 | 0.04 | 0.02 |      |      |      | 1.79 | 1.57 | 0    |
| 22          | 4                           |      |      | 16   | 15   | 1    | 36    | 22                | 0    |      |      | 0.12 | 0.01 | 0    | 0    |      |      | 1.67 | 1.16 | 0    |
| 24          |                             |      |      | 60   |      |      | 60    | 24                |      |      |      | 0.2  |      |      |      |      |      | 1.79 |      |      |
| 25          |                             |      |      |      |      |      |       | 25                |      |      |      |      |      |      |      |      |      |      |      |      |
| 26          |                             |      |      | 96   | 15   | 8    | 119   | 26                |      |      |      | 0.1  | 0.03 | 0.02 |      |      |      | 2.5  | 1.12 | 1    |
| All         | 25                          | 37   | 250  | 4617 | 962  | 470  | 6361  | All               | 0.02 | 0.02 | 0.01 | 0.17 | 0.16 | 0.03 | 1.92 | 0.73 | 1.36 | 3.27 | 2.48 | 2.05 |

### **11.27 CABIN GEOMETALLURGICAL MODELING**

Areas of material characterized by potentially reduced or refractory recovery were identified and modeled by incorporating additional aspects as:

- Carbon (0 or 2) intensity
- Silicification (0 or 2) intensity

The carbon and silicification models were created using the qualitative intensity values (1-3, 3 being high). Intensity values were then modeled as indicator isoshells for intensity  $\geq 2$  using Leapfrog Geo v5.1. The occurrence of carbon pods appears to be coincident with faulting and can be in the hanging wall or fault wall of the faults. Carbonaceous pods are of variable thickness. Controlling trends were applied using the fault structure model. These were then imported to Minesight and the block model field INDCB was coded from the isoshells. All modeled carbon occurs outside of the resource pit shell. Silicification occurs within the resource pit shell with the majority associated with waste.

CN/FA ratios were then used to populate the block model in areas where carbon and sulfide data is not available. The recovery model was created using the same interpolation methodology as the gold resource estimate. The results of the model along with the carbon model were then used to populate the risk code as shown in Table 11-4.

### **11.28 CABIN DENSITY**

Density was assigned to the block model based on previous analysis outlined in the FS completed in 2018. A density value of 13.35 ft<sup>3</sup>/t was assigned to material with a grade  $>0.005$  opt. The lower average density of the oxide mineralized material is a function of decalcification, argillization, and oxidation. Any blocks coded as fill were then assigned a tonnage factor of 16.7 ft<sup>3</sup>/t. A summary of Tonnage Factors by rock type is provided in Table 11-5.

Additional test work is being conducted in 2020-2021 to better assign density by lithology and alteration.

### **11.29 CABIN VARIOGRAPHY AND INTERPOLATION SEARCH CRITERIA**

The purpose of the domains is to divide the data into meaningful pods within the stratigraphic units offset by faulting as illustrated in Figure 11-30. The northwest faults are the youngest in the system and are not mineralized but provide the greatest offsets. Northeast trending faults and fractures are both mineralized and offsetting. Boundary conditions tested produced mixed results. The domain boundaries are considered hard boundaries based on visual offset of features and mineralized planes across the boundaries.

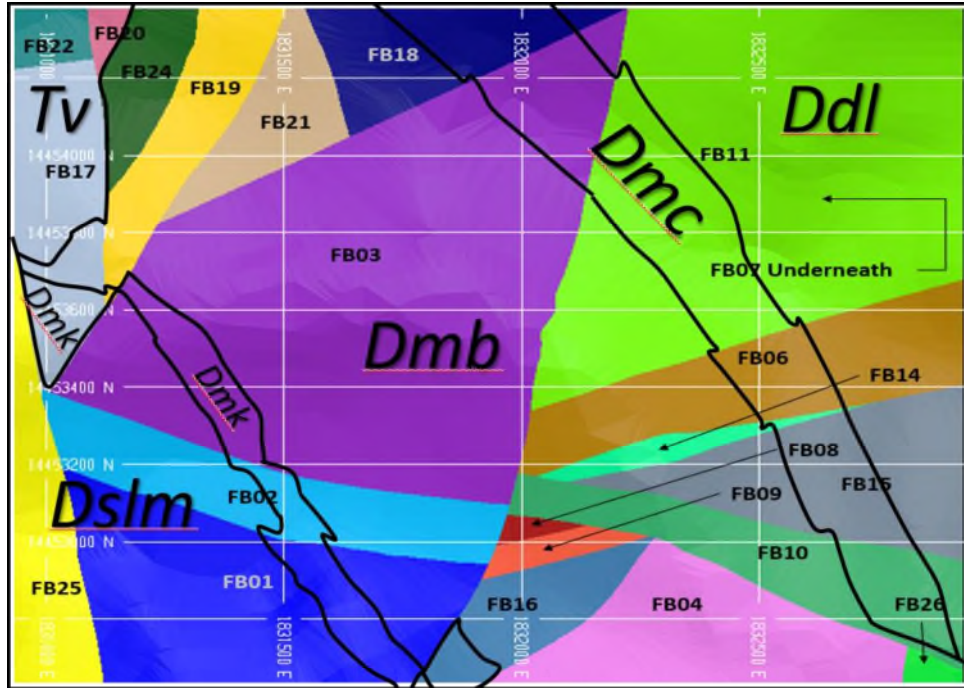


Figure 11-30: Cabin Structural Domains and Stratigraphic Units (MTS, 2020)

Variograms (correlograms) were constructed for the capped and composited assay values. To facilitate this work MTS used the MineSight Data Analysis module to create variograms for each mineral domain. MTS commonly considers 400 samples as the minimum number of composites for variogram modeling. Table 11-13 shows the number of composites for subdomains is commonly less than 400 samples.

The nugget ( $C_0$ ) picked at 0.17 was determined with a downhole variogram. Figure 11-31 shows the downhole variogram model used for the Cabin grade estimation. Directional variograms utilized a 50-foot lag.

Because of the limited number of samples in each fault block, Variograms were completed for the Dmb (STRAT=700) and the Dmk (STRAT = 800). A variogram model was also completed on the combined Dmb and Dmk (STRAT = 700 + 800) composites. MTS chose the combined 700-800 for the variogram for grade estimation. The variogram model summarized in Figure 11-32 used a correlogram model.

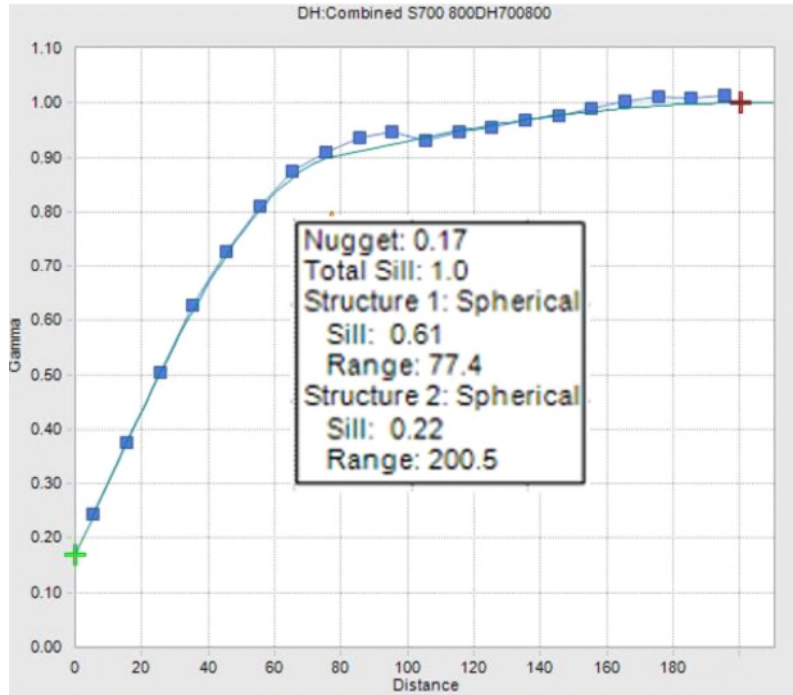


Figure 11-31: Downhole Variogram for Combined 700-800 (MTS, 2020)

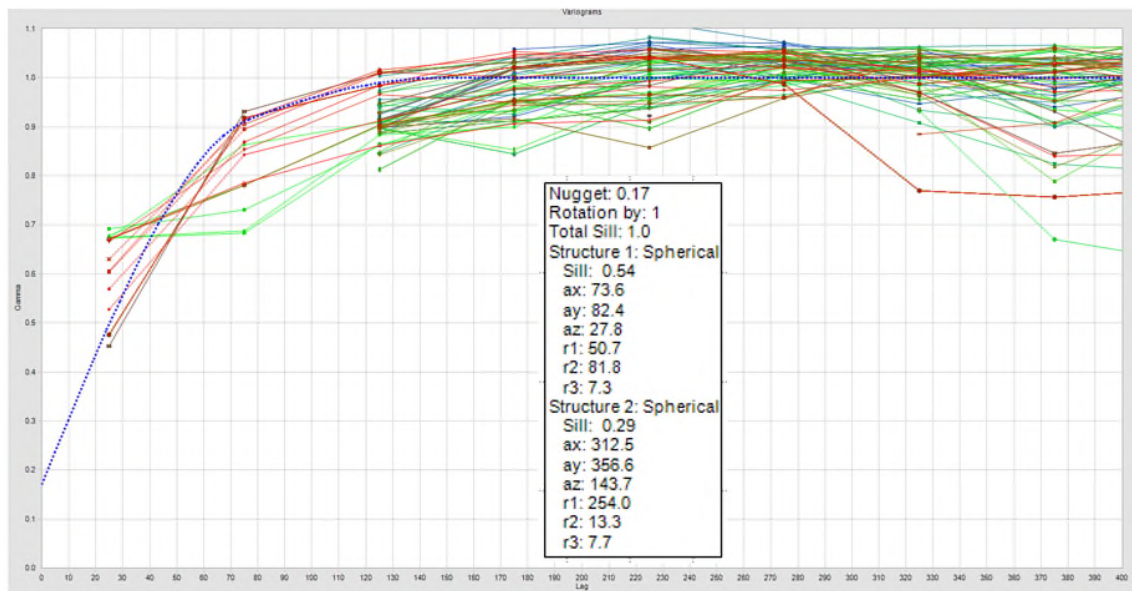


Figure 11-32: Variogram Model for Combined Dmb and Dmk (MTS, 2020).

The Cabin resource block model was constructed in two phases. To provide better definition of fault block and stratigraphic boundaries without using a sub-cell methodology, MTS chose to construct an initial block model with a block size of 10 ft x 10 ft x 10 ft (10x10 model). Estimation and model validation were completed on the 10x10 model. The final 10x10 model was reblocked to a 20 ft x 20 ft x 20 ft block size (20x20 model) using the MineSight MSDART module.

Grade estimation, model validation and Mineral Resource Classification were accomplished for the 10x10 model. Model validation was also completed on the 20x20 model after reblocking to confirm the reblocking was accomplished correctly.

The limits for the 10x10 model are summarized in Table 11-14. The limits were determined by the extent of the geology model provided.

**Table 11-14: Model Extents for 10x10 Block Model (MTS, 2020)**

| Direction | Min      | Max      | Cell Size | Number Blocks |
|-----------|----------|----------|-----------|---------------|
| Easting   | 1828730  | 1833030  | 10        | 430           |
| Northing  | 14452020 | 14454700 | 10        | 268           |
| Elevation | 6200     | 9100     | 10        | 290           |

### 11.30 CABIN GRADE ESTIMATION

Grade estimation was completed in four passes with expanding search and fewer samples for each consecutive pass. Table 11-15 summarizes the estimation plan. The grade estimation was accomplished for uncapped and capped gold grades. Additional grade estimations included Inverse Distance Weighting and an outlier restriction. The IDW estimate was for comparison to the OK estimate used for the reported resource estimate. The outlier restriction estimate was used for comparison but reduced the overall grade an unreasonable amount when compared to mine production data.

**Table 11-15: Cabin Grade Estimation Plan (MTS, 2020)**

| Parameter           | Pass1 | Pass 2 | Pass 3 | Pass 4 |
|---------------------|-------|--------|--------|--------|
| Search Major        | 100   | 150    | 250    | 400    |
| Search Semi         | 75    | 100    | 200    | 250    |
| Search Minor        | 40    | 60     | 80     | 80     |
| Min Samples         | 7     | 5      | 5      | 2      |
| Max Samples         | 9     | 9      | 7      | 7      |
| Max from DH         | 3     | 3      | 3      | 3      |
| Rot1 LRL            | 166.1 | 166.1  | 166.1  | 166.1  |
| Rot2 LRL            | -25.5 | -25.5  | -25.5  | -25.5  |
| Rot3 LRL            | 17.8  | 17.8   | 17.8   | 17.8   |
| Outlier Restriction |       |        |        |        |
| Grade Threshold     | 3     | 3      | 3      | 3      |
| Distance Threshold  | 30    | 30     | 30     | 30     |
| Code Matching       | STRAT | STRAT  | STRAT  | STRAT  |
| Contacts            | Hard  | Hard   | Hard   | Hard   |
| Code Matching       | FBLK  | FBLK   | FBLK   | FBLK   |
| Boundaries          | Hard  | Hard   | Hard   | Hard   |

**11.31 CABIN MINERAL RESOURCE CLASSIFICATION**

Mineral Resources were classified into Measured, Indicated, and Inferred categories based on CIM Definition Standards. Parameters used for classification are listed in Table 11-16.

**Table 11-16: Cabin Classification Parameters**

| Classification | Criteria                       |
|----------------|--------------------------------|
| Measured       | Three drill holes within 35 ft |
|                | with 1 drill hole within 25 ft |
| Indicated      | Two drill holes within 85 ft   |
|                | with 1 drill hole within 60 ft |
| Inferred       | Two drill holes within 150 ft  |

Source: MTS, 2020

Mineral Resource Classification was completed in a two-step process. A preliminary classification was determined using confidence limits. The confidence limits were based on a 7500 ton/mo production schedule.

The confidence limit criteria for Measured Mineral Resources required 3 drill holes within 35 ft with 1 drill hole within 25 ft. Indicated Mineral Resources required 2 drill holes within 85 ft with one of the drill holes within 60 ft. Inferred Mineral Resources required 2 drill holes within 150 ft.

A preliminary classification (PCLAS) was coded to the block model using MineSight scripts. The preliminary classification shows a “Spotted Dog” texture (Figure 11-33) with isolated blocks of Measured and Inferred classified blocks within the blocks generally classified as Indicated.

To remove the “Spotted Dog”, bench polygons were constructed on 20 ft intervals. The bench polygons were extruded vertically  $\pm 10$  ft to construct solids. The solids were used to code the blocks to Indicated Mineral Resource Classification. All blocks within the bench solids were classified as Indicated (MII=2). Indicated blocks outside the bench solids were modified to Inferred (MII = 3). The results from that classification are shown in Figure 11-34. Again, Measured blocks were then reclassified as Indicated based on on-going work to determine density values and mineralogy that could potentially affect recovery.

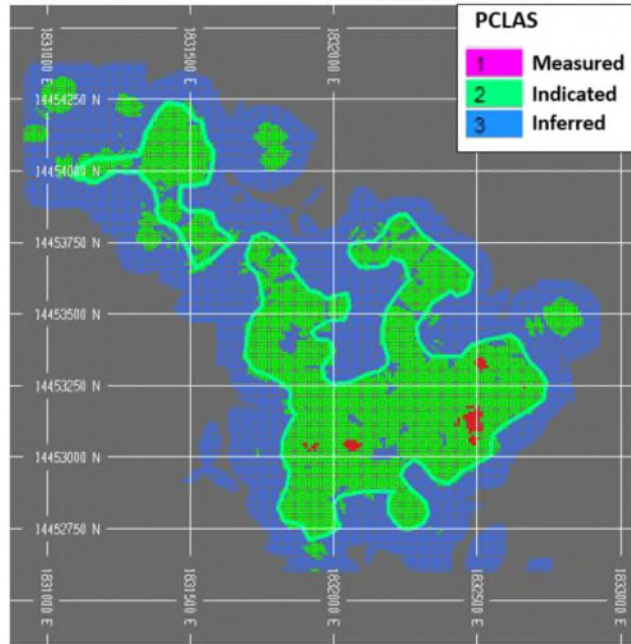


Figure 11-33: PCLAS Preliminary Classification with Indicated Polygon (Elevation 7090) (MTS, 2020)

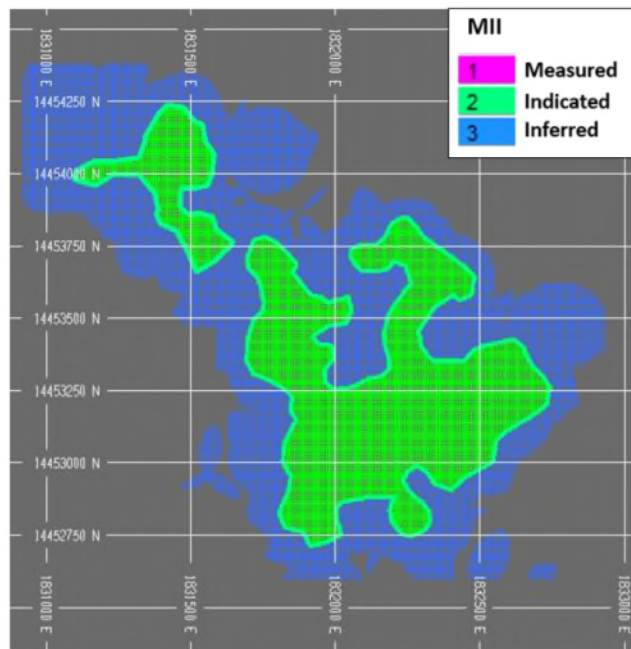


Figure 11-34: Final Classification with Indicated Polygon (Elevation 7090) (MTS, 2020)

### 11.32 CABIN BLOCK MODEL VALIDATION

Various measures were implemented to validate the initial 10x10x10 Cabin block model and reblocked 20x20x20 block model. These measures included the following:

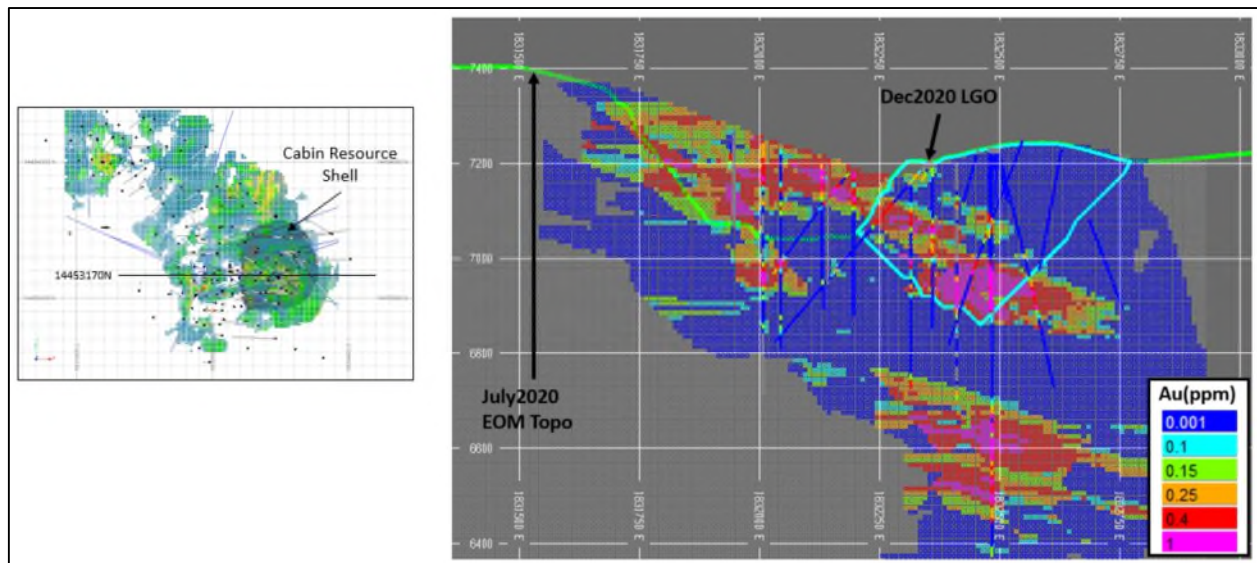
- Comparison of drill hole composites with resource block grade estimates from all zones visually in plan and section views;



- Global bias check;
- Swath plot analysis (drift analysis) comparing the inverse distance model with the NN model and declustered composite grades; and
- HERCO change of support.

**11.32.1 Visual Comparison**

A visual inspection of gold grades comparing block model and composite grades was completed in cross-section and plan. The visual inspection indicated the block grades compare well to the composite grades. Figure 11-35 shows section 14453170 N. Included on the section are the End-of-Month (EOM) surface from July 2020 and the Dec. 2020 \$1,750 Lerchs Grossman Optimization (LGO).



**Figure 11-35: Plan View of Visual Validation Cross Section Locations for Estimated Grades, Cabin (MTS, 2020)**

**11.32.2 Global Bias Check**

A global bias check was completed comparing the estimated grade to the NN grade by stratigraphic unit. The grade estimate is considered to be unbiased when the Relative percent difference between the estimated grade and the NN grade are within  $\pm 5\%$ .

Table 11-17 summarizes the global bias by stratigraphic unit. The Ddl stratigraphic unit shows a slight positive bias with a relatively small number of blocks and the mean grade is also low. The global bias for the stratigraphic units that contain significant mineralization (Dmb and Dmk) is within the  $\pm 5\%$  criteria. The Cabin resource model is considered to be unbiased.

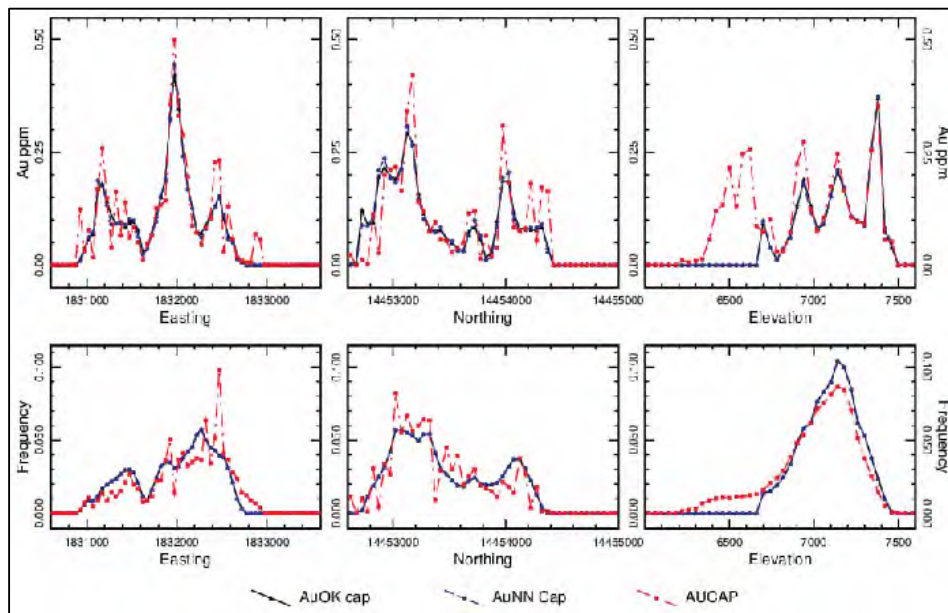
**Table 11-17: Global Bias Check by Stratigraphic Unit (MTS, 2020)**

| Stratigraphic Unit<br>(Model Code) | Number<br>Blocks | Mean<br>AUCAP (ppm) | Mean<br>AUCAPNN (ppm) | %Rel<br>Difference |
|------------------------------------|------------------|---------------------|-----------------------|--------------------|
| Tv (100)                           | 2,390            | 0.0139              | 0.0111                | 25.30%             |
| Ddl (500)                          | 5,574            | 0.018               | 0.0168                | 7.00%              |
| Dmc (600)                          | 24,170           | 0.0086              | 0.0084                | 3.10%              |
| Dmb (700)                          | 458,340          | 0.1116              | 0.1114                | 0.20%              |
| Dmk (800)                          | 85,866           | 0.1065              | 0.1038                | 2.60%              |
| DSIm (900)                         | 25,181           | 0.0363              | 0.0355                | 2.10%              |

**11.32.3 Swath Plots**

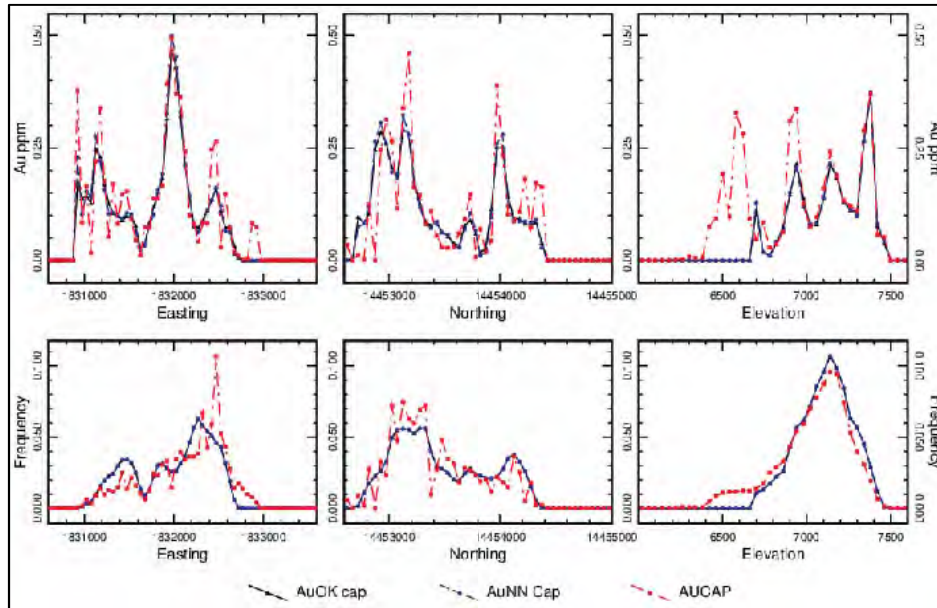
Swath plots were generated for gold grades along east-west and north-south directions, and also by elevation for the global model and individual domains. Swath widths were 50 ft wide for east-west, north-south and elevation. Figure 11-36, Figure 11-37, and Figure 11-38 show swath plots for all stratigraphic units, Dmb and Dmk respectively.

According to the swath plots, there is good correlation between the modeling methods with the composites used. While there is a certain amount of smoothing that occurs around the peaks and valleys and in areas with lower block counts, overall, the models fit well with the composite dataset.



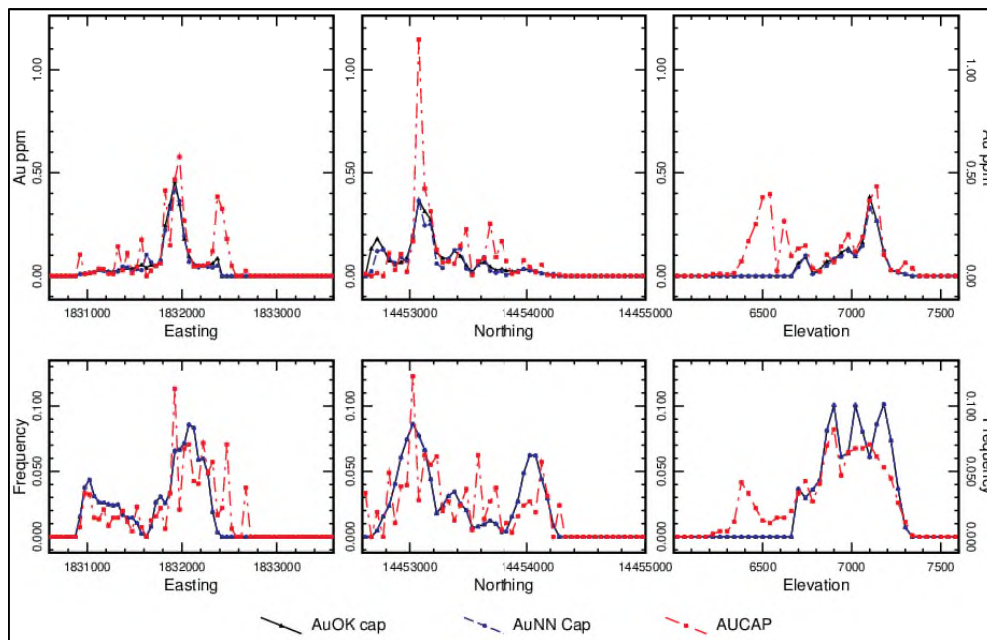
Source: MTS, 2020

**Figure 11-36: Cabin Swath Plot for All Strat; Capped Grades; 10x10x10 Block Model; Indicated Mineral Resources**



Source: MTS, 2020

**Figure 11-37: Cabin Swath Plot for Dmb (700); Capped Grades; 10x10x10 Block Model; Indicated Mineral Resource**



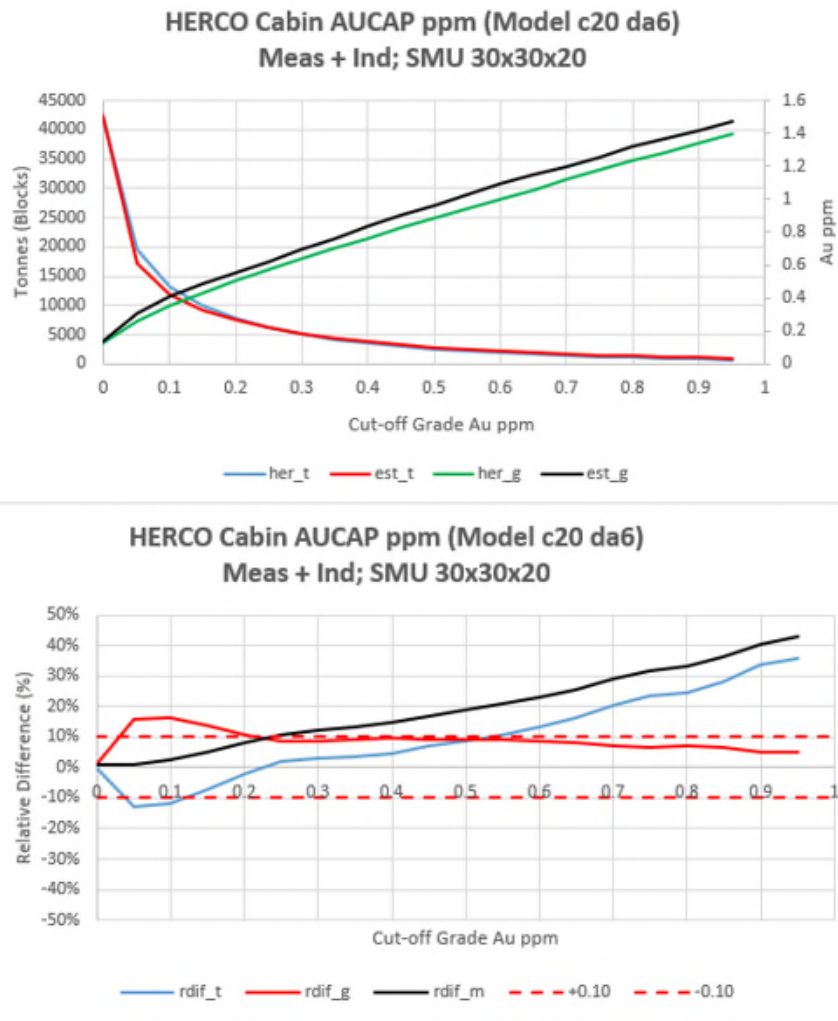
Source: MTS, 2020

**Figure 11-38: Cabin Swath Plot for Dmk (800); Capped Grades; 10x10x10 Block Model; Indicated Mineral Resources**

**11.33 CABIN CHANGE OF SUPPORT ANALYSIS**

Change of support was investigated using HERCO plots and a 30x30x20 SMU. Figure 11-39 shows the HERCO plot for AUOK cap grade in ppm Au. The upper plot of the HERCO grade-tonnage curve indicates the grade estimate is

under smoothed for grade at a 0.25 ppm gold cut-off grade. The lower plot showing percent relative differences indicates the grade estimate is approximately 10% high at a 0.007 oz/ton (0.25 ppm) Au cut-off and the tonnage estimate is approximately 2 percent high.



Source: MTS, 2020

**Figure 11-39: Cabin HERCO Change of Support Plot for Au(ppm) for Indicated Mineral Resources Reblock 20x20 Model**

The 10x10 model was reblocked to a 20x20x20 block size using the MineSight functions in MSDART. The larger block size matches the block size for the other block models in the Gold Bar project and permits a common block model for the Gold Bar project. The reblocking also softens the hard boundaries used in the 10x10 model.

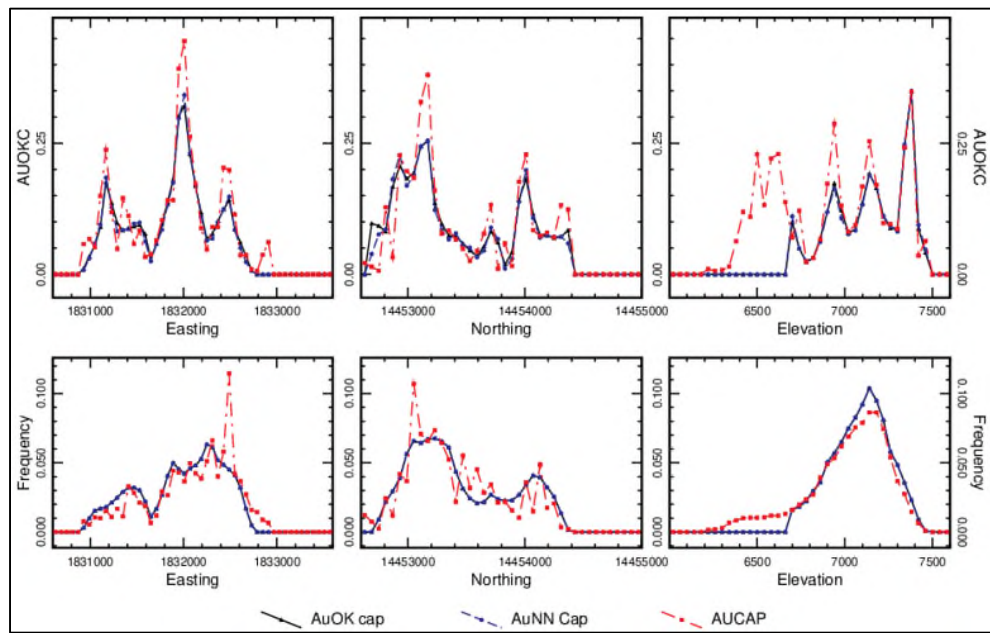
A visual inspection of gold grades comparing block model and composite grades was completed in cross-section and plan. The visual inspection indicated the block grades compare to the composite grades.

A global bias check of the reblocked 20x20 model (Table 11-18). The global bias is similar to the 10x10 model and indicates the reblocking accomplished successfully.

**Table 11-18: Global Bias Check by Stratigraphic Unit for 20x20 Block Model (MTS, 2020)**

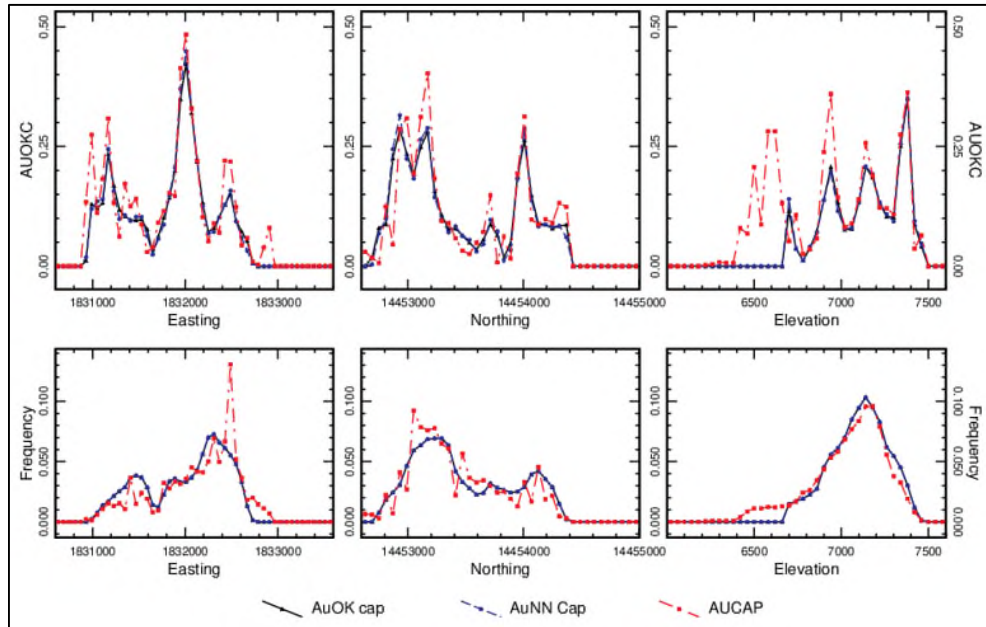
| Stratigraphic Unit<br>(Model Code) | Number<br>Blocks | Mean        | Mean          | %Rel       |
|------------------------------------|------------------|-------------|---------------|------------|
|                                    |                  | AUCAP (ppm) | AUCAPNN (ppm) | Difference |
| Tv (100)                           | 607              | 0.0263      | 0.0207        | -27.04%    |
| Ddl (500)                          | 1,275            | 0.0187      | 0.0175        | -7.06%     |
| Dmc (600)                          | 4,411            | 0.0088      | 0.0087        | -1.56%     |
| Dmb (700)                          | 74,260           | 0.1084      | 0.1048        | -3.41%     |
| Dmk (800)                          | 19,627           | 0.1064      | 0.1034        | -2.95%     |
| DSIm (900)                         | 13,826           | 0.0412      | 0.0388        | -6.12%     |

Swath plots were constructed to confirm the reblocking. Swaths were constructed at 60 ft intervals in the East-West and North-South directions and 40 ft intervals for elevations to better fit the block size. Figure 11-40, Figure 11-41, and Figure 11-42 show swath plots for All stratigraphic units, Dmb and Dmk respectively. Swaths of the 20x20 model are similar to Swath Plots for the 10x10 model.



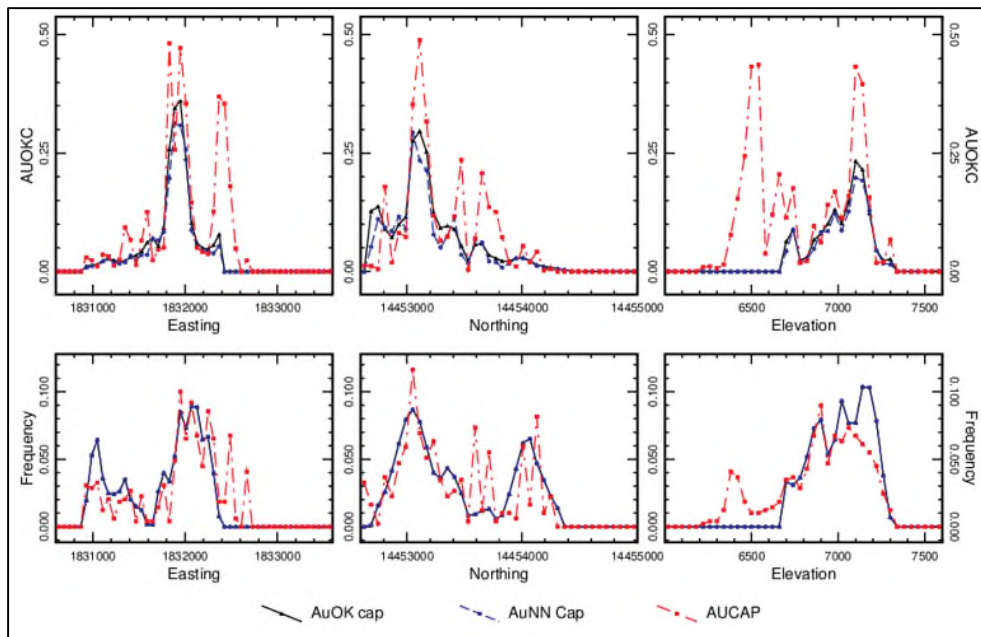
Source: MTS, 2020

**Figure 11-40: Cabin Swath Plot for All Strat; Capped Grades; 20x20x20 Block Model; Indicated Mineral Resources**



Source: MTS, 2020

**Figure 11-41: Cabin Swath Plot for Dmb (700); Capped Grades; 20x20x20 Block Model; Indicated Mineral Resources**



Source: MTS, 2020

**Figure 11-42: Cabin Swath Plot for Dmk (800); Capped Grades; 20x20x20 Block Model; Indicated Mineral Resources**

**11.34 CABIN ECONOMIC INPUT PARAMETERS**

Cut-off grade for the Mineral Resource Statement was determined based on the following equation:

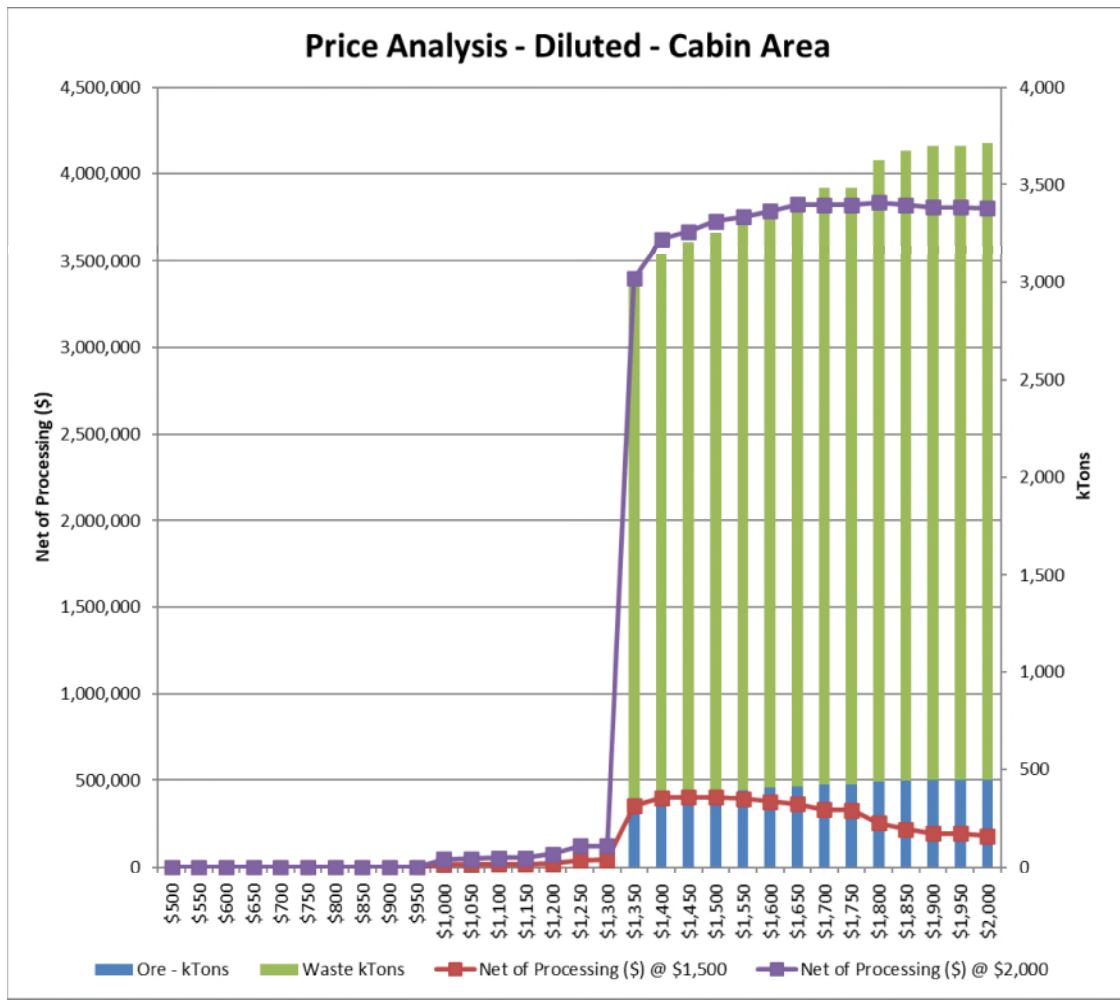
$$\text{Cut-off} = ((1+\text{DIL}) * (\text{MCo} + \text{PC} + \text{SR} + \text{R})) / (\text{Price} * \text{Rec} * \text{Factor})$$

- DIL = Dilution: 0 for the resource
- MCo = Mining Cost: US\$3.19/t for ore, US\$1.72/t for waste
- PC = Total Ore Processing Cost: US\$8.40/t (combined ROM and agglomerated, stacked ore)
- Price = Net Gold Sales Price: US\$1,725/oz
- Rec = Recovery: 72% ROM oxide, 78% crushed oxide, 50% mid-carbon
- SR=Smelting and Refining: \$2.013/oz
- R=Royalty: 4% NPI
- Factor = Factor for unit conversion: 1

The resulting cu-toff grade for Cabin rounds to 0.007 oz/t Au.

**11.35 CABIN MINERAL RESOURCE SENSITIVITY**

The Gold Bar Mineral Resource is reported below at variable prices within the 2020 Resource Pit to demonstrate the sensitivity of the resource. The sensitivity analysis was completed using \$1500/oz Au price and \$2000/oz Au price. These sensitivities are provided in Figure 11-43 for diluted resource.



Source: IMC, 2020

**Figure 11-43: Cabin Sensitivity within the Gold Pick 2020 Resource Pit**

**11.36 GOLD BAR SOUTH ASSAY DATA POPULATION DOMAIN ANALYSIS AND CAPPING**

The Gold Bar South drilled assay database used in this study consisted of 504 drill holes and approximately 27,800 gold assay intervals. The cut-off date for data used in this resource estimate was September 3, 2020.

Most of the drilling supporting the resource estimate was performed using RC methods with minimal core drilling (< 8%). However, when core drilling has been used, as described in Section 9.1 of this report, correlations are adequate to good, providing sufficient confidence for application of the data in resource modeling. RC drilling for all of Gold Bar South has been above the water table; therefore, there are no issues related to drilling wet RC holes in the database.

Using lognormal probability plots and quantile analysis as guides, in conjunction with an examination of the distribution of drill hole data, metal removed, and effect on coefficient of variance, capping thresholds were selected for each interpolation domain for Gold Bar South. An inflection point on each probability plot was selected to identify assays that are to be considered “outliers” to the general distribution and then compared to other parameters and adjusted as necessary to achieve the best fit. Assays were “capped” or set back to the defined threshold. The thresholds identified are tabulated below in Table 11-19.

**Table 11-19: Assay Capping Statistics by Interpolation Domain (McEwen, 2020)**

| <b>ZONE</b> | <b>Number Samples Capped</b> | <b>Capped Value</b> |
|-------------|------------------------------|---------------------|
| 102         | 1                            | 0.45                |
| 105         | 7                            | 0.4                 |
| 107         | 3                            | 0.5                 |
| 112         | 6                            | 0.95                |
| 132         | 1                            | 0.7                 |
| 133         | 11                           | 0.25                |
| 134         | 3                            | 1.4                 |
| 135         | 6                            | 0.4                 |
| 148         | 9                            | 1.2                 |
| 202         | 14                           | 1.2                 |
| 205         | 6                            | 0.55                |
| 207         | 16                           | 0.7                 |
| 212         | 19                           | 1.5                 |
| 232         | 12                           | 2.1                 |
| 233         | 13                           | 2                   |
| 234         | 17                           | 4                   |
| 235         | 18                           | 1.5                 |
| 236         | 2                            | 1.5                 |
| 242         | 6                            | 0.5                 |
| 247         | 2                            | 1.5                 |
| 248         | 9                            | 4                   |
| 300         | 4                            | 0.2                 |
| 400         | 4                            | 0.4                 |
| 600         | 20                           | 6                   |
| 609         | 5                            | 3                   |
| 610         | 15                           | 2.6                 |
| 611         | 28                           | 3                   |
| 623         | 4                            | 0.4                 |
| 629         | 25                           | 4                   |
| 630         | 4                            | 1.3                 |
| 631         | 24                           | 2.5                 |
| 637         | 1                            | 0.4                 |



**GOLD BAR PROJECT**  
**FORM 43-101F1 TECHNICAL REPORT – FEASIBILITY STUDY**

| ZONE | Number Samples Capped | Capped Value |
|------|-----------------------|--------------|
| 639  | 11                    | 2            |
| 640  | 3                     | 0.5          |
| 643  | 6                     | 1.2          |
| 644  | 4                     | 1.5          |
| 645  | 4                     | 0.6          |
| 646  | 7                     | 0.55         |
| 649  | 2                     | 3            |
| 650  | 16                    | 0.8          |
| 701  | 8                     | 0.15         |
| 711  | 1                     | 0.4          |

**11.37 GOLD BAR SOUTH COMPOSTING**

After capping, the Au sample grades were composited to 10 ft fixed length intervals. After compositing, the composites were re-coded with the domain code. Table 11-20 summarizes the composite statistics.

**Table 11-20: Composite Statistics (McEwen, 2020)**

| Domain | No. Intervals | Minimum | Maximum | Mean  | Standard deviation | CV    | % Reduction applied to CV by Capping and Compositing |
|--------|---------------|---------|---------|-------|--------------------|-------|--|
| 189    | 19            | 0.003   | 0.066   | 0.012 | 0.016              | 1.405 | 37%  |
| 197    | 219           | 0.002   | 0.35    | 0.02  | 0.053              | 2.625 | 32%  |
| 198    | 199           | 0.001   | 2.547   | 0.448 | 0.563              | 1.257 | 12%  |
| 208    | 101           | 0.001   | 1.14    | 0.108 | 0.26               | 2.405 | 23%  |
| 210    | 371           | 0.001   | 4.73    | 0.41  | 0.782              | 1.904 | 9%   |
| 212    | 326           | 0.001   | 5       | 0.696 | 1.011              | 1.453 | 10%  |
| 214    | 294           | 0.001   | 0.76    | 0.061 | 0.138              | 2.252 | 28%  |
| 215    | 313           | 0.001   | 2.4     | 0.082 | 0.302              | 3.677 | 17%  |
| 216    | 37            | 0.003   | 0.442   | 0.061 | 0.103              | 1.695 | 8%   |
| 217    | 275           | 0.003   | 0.94    | 0.069 | 0.131              | 1.902 | 43%  |
| 220    | 647           | 0.001   | 1.76    | 0.075 | 0.213              | 2.854 | 18%  |
| 221    | 17            | 0.003   | 0.901   | 0.174 | 0.278              | 1.596 | 20%  |
| 222    | 375           | 0.003   | 5.33    | 0.428 | 0.694              | 1.621 | 16%  |
| 224    | 170           | 0.001   | 0.46    | 0.052 | 0.093              | 1.778 | 63%  |
| 228    | 239           | 0.001   | 2.8     | 0.441 | 0.654              | 1.483 | 12%  |
| 229    | 159           | 0.001   | 1.76    | 0.057 | 0.17               | 3     | 36%  |
| 231    | 251           | 0.002   | 1.07    | 0.105 | 0.209              | 1.997 | 20%  |
| 237    | 31            | 0.001   | 0.941   | 0.126 | 0.255              | 2.024 | 42%  |
| 243    | 3             | 0.004   | 0.017   | 0.011 | 0.007              | 0.625 | 14%  |
| 245    | 399           | 0.001   | 1.646   | 0.112 | 0.236              | 2.107 | 35%  |
| 247    | 250           | 0.002   | 1.79    | 0.169 | 0.339              | 2.006 | 23%  |
| 249    | 48            | 0.002   | 1.035   | 0.348 | 0.323              | 0.927 | 24%  |
| 301    | 1445          | 0.001   | 0.495   | 0.01  | 0.03               | 2.924 | 19%  |
| 311    | 209           | 0.001   | 0.443   | 0.031 | 0.054              | 1.744 | 20%  |
| 321    | 558           | 0.001   | 4.305   | 0.042 | 0.251              | 5.971 | 11%  |
| 346    | 1874          | 0.001   | 2.537   | 0.041 | 0.118              | 2.909 | 12%  |

| Domain | No. Intervals | Minimum | Maximum | Mean  | Standard deviation | CV    | % Reduction applied to CV by Capping and Compositing |
|--------|---------------|---------|---------|-------|--------------------|-------|--|
| 601    | 3146          | 0.001   | 4.015   | 0.065 | 0.269              | 4.168 | 19%  |
| 611    | 324           | 0.001   | 5.39    | 0.441 | 0.983              | 2.227 | 23%  |
| 621    | 498           | 0.002   | 7.38    | 0.691 | 1.281              | 1.852 | 16%  |
| 631    | 485           | 0.001   | 3.12    | 0.264 | 0.565              | 2.137 | 11%  |
| 641    | 1243          | 0.001   | 2.77    | 0.059 | 0.277              | 4.68  | 9%   |
| 651    | 104           | 0.001   | 1.78    | 0.126 | 0.305              | 2.418 | 11%  |

**11.38 GOLD BAR SOUTH GEOMETALLURGICAL MODELING**

McEwen recovers gold by using sodium cyanide (NaCN) in a heap leach operation. Historic and recent metallurgical testing indicates that un-oxidized, decalcified, high-carbon, high-sulfide or strongly silicified mineralization has problematic recovery characteristics. Areas of material characterized by potentially reduced or refractory recovery were identified and modeled by incorporating additional aspects as:

- Carbon; no measured carbon observed within the economic cone
- Sulfide; no measured sulfide observed within the economic cone
- Silicification indicator intensities of 0, 2, 2.5 and 3
- Cn/FA assay ratios; Cn/FA ratios <75% represent approximately 7% of the dataset

A lower recovery factor of 61% was assigned to the Gold Bar South deposit based on the strong silicification identified through the ore body. Metallurgical testing is on-going.

**11.39 GOLD BAR SOUTH HISTORIC MINING DUMPS**

No fill material left in dumps from previous mining was identified in the Gold Bar South area.

**11.40 GOLD BAR SOUTH DENSITY**

Density samples were taken and analyzed through the Gold Bar South deposit in 2019 and 2020. Table 11-21 outlines the density factors applied to the 2020 resource estimate. Density was applied based on stratigraphic unit and alteration type.

**Table 11-21: Gold Bar South Tonnage Factors by Rock Type (McEwen, 2020)**

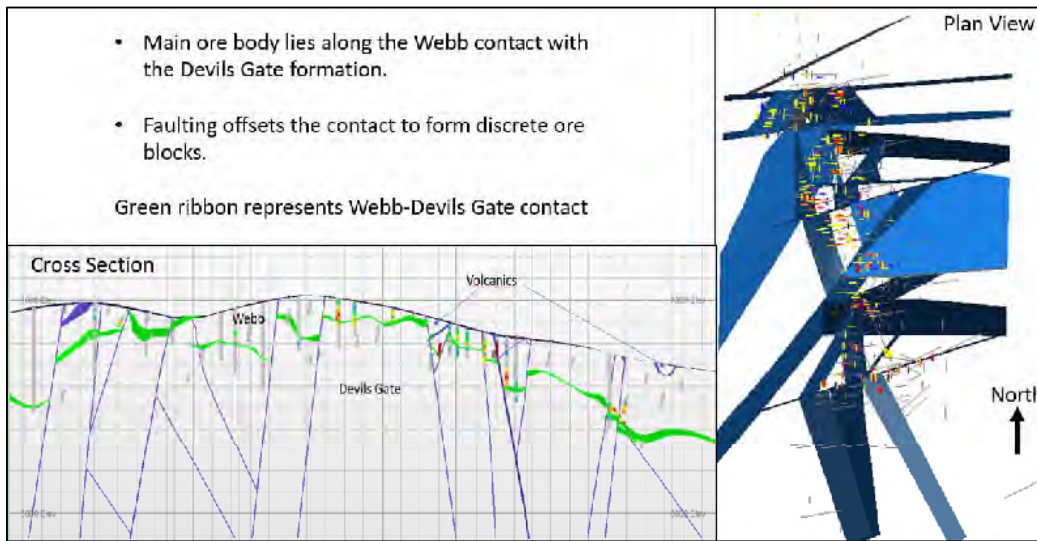
| Units                           | g/cm <sup>3</sup> | Tonnage Factor | Density (ft <sup>3</sup> /st) |
|---------------------------------|-------------------|----------------|-------------------------------|
| Webb: Silicification Int 2-3    | 2.32              | 13.78          | 0.073                         |
| Webb: not silicified or breccia | 2.22              | 14.41          | 0.069                         |
| Clay Intensity 3                | 2.25              | 14.25          | 0.070                         |
| Webb: Breccia: Int>2            | 2.37              | 13.51          | 0.074                         |
| Ddg: Breccia: Int >2            | 2.47              | 12.96          | 0.077                         |
| Ddg not considered Breccia      | 2.51              | 12.74          | 0.078                         |
| Volcanic Units                  | 2.20              | 14.53          | 0.069                         |

Additional test work is being conducted in 2020-2021 to better assign density by lithology and alteration.

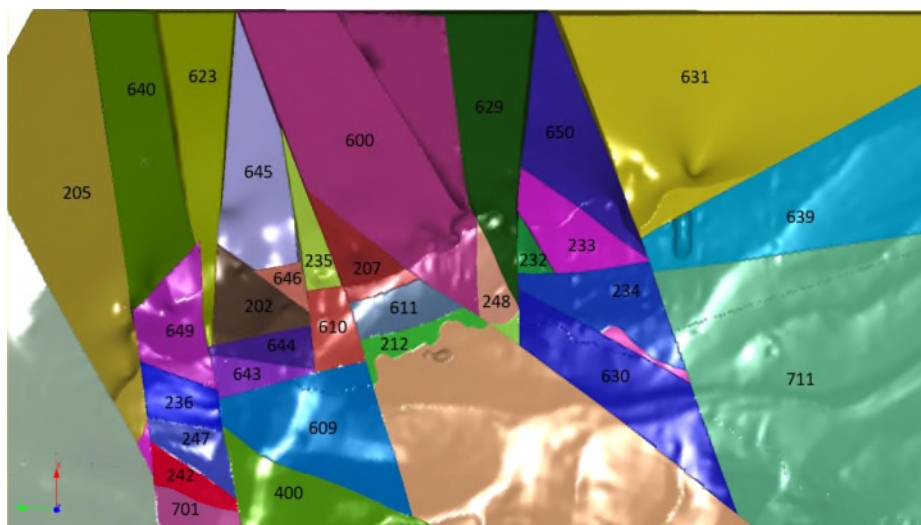
**11.41 GOLD BAR SOUTH VARIOGRAPHY AND INTERPOLATION SEARCH CRITERIA**

The purpose of the domains is to divide the data into meaningful pods within the Webb (Mw), Devils Gate (Ddg) and Tertiary volcanic (Tv) stratigraphic units offset by faulting as illustrated in Figure 11-44. Domains shown in Figure 11-45 and Figure 11-46 were created from this combination of fault offsets and stratigraphic boundaries. Fault/fracture sets shown in Figure 11-44 are divided into three broad trend directions. An ENE-trending, near-vertical, fracture set that acts as a minor host to mineralization. The NE-trending fault set that predominately offsets mineralization and hosts localized mineralization. The NS-NNW trending fault set.

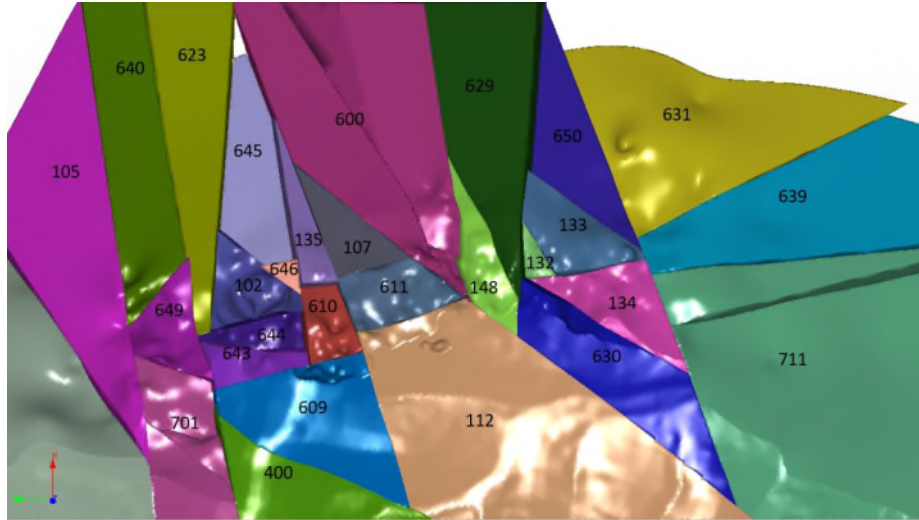
Mineralization is primarily hosted along the contact in a karsted collapse breccia within the Webb formation. Mineralization also occurs in the Devils Gate but is limited to fracturing within the more massive limestone near the contact with Webb.



**Figure 11-44: Structural Model for Gold Bar South Deposit (McEwen, 2020)**



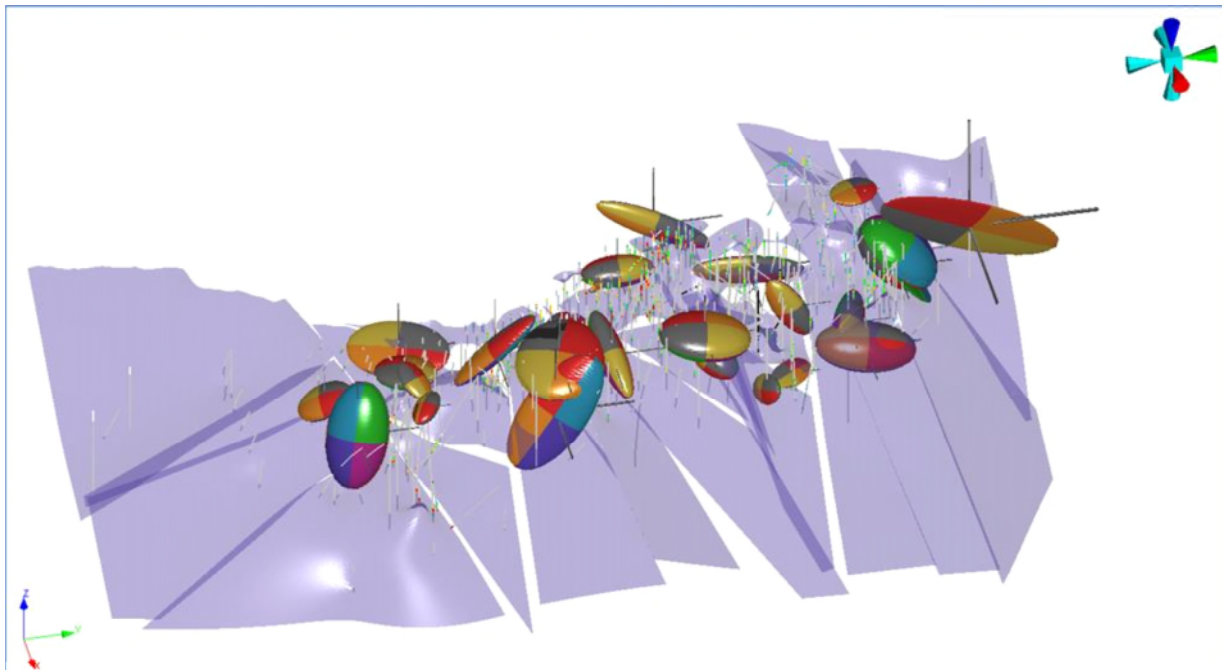
**Figure 11-45: Domains and Codes for the Webb Formation (McEwen, 2020)**



**Figure 11-46: Domains and Codes for the Devils Gate Formation (McEwen, 2020)**

Variograms were constructed independently for the composited and capped assay values for each interpolation domain. To facilitate this work McEwen used the Snowden Supervisor tool kit to develop a series of variograms, for each mineral domain.

The nugget value was determined from down hole variograms for each domain and then applied to the variogram models. Nugget values for Gold Bar South are low between 0.005-0.2. The nugget and short-range structures tend to influence 50-70% of the total variogram model within an average of 90 feet for the domains. The search ellipsoids shown in Figure 11-47 generated from variography are typically oriented along the Mw-Ddg contact and the strike and dip change. Search distances listed in Table 11-22 were initially set to 70% of the distance to sill and then adjusted up or down based on review of multiple model runs. Search distances were adjusted to minimize spread of mineralization beyond what was believed to be reliable distances from composites.



**Figure 11-47: Gold Bar South Grade Estimation Search Ellipsoids and Structural Mapping (McEwen, 2020)**

**Table 11-22: Gold Bar South Model Search Parameters (McEwen, 2020)**

| Domain | % of Vario for Search Distance | Distance X | Distance Z | Distance X | Angle 1 | Angle 2 | Angle 3 |
|--------|--------------------------------|------------|------------|------------|---------|---------|---------|
| 102    | 70                             | 55         | 108        | 20         | 50      | 30      | 95      |
| 105    | 70                             | 170        | 125        | 65         | 175     | 135     | -150    |
| 112    | 70                             | 165        | 80         | 48         | 0       | 0       | 90      |
| 132    | 70                             | 250        | 74         | 46         | -165    | 45      | 85      |
| 133    | 80                             | 138        | 75         | 35         | 50      | 30      | 100     |
| 134    | 60                             | 200        | 115        | 35         | 110     | 30      | 180     |
| 135    | 60                             | 120        | 49         | 52         | 30      | 40      | 130     |
| 148    | 80                             | 75         | 50         | 20         | 105     | 20      | 170     |
| 202    | 60                             | 160        | 65         | 45         | 110     | 95      | -120    |
| 205    | 70                             | 180        | 135        | 70         | -160    | 140     | 175     |
| 607    | 70                             | 185        | 125        | 110        | 60      | 10      | 40      |
| 212    | 70                             | 95         | 32         | 25         | 55      | 90      | 175     |
| 232    | 70                             | 250        | 74         | 46         | -165    | 45      | 85      |
| 233    | 80                             | 138        | 75         | 35         | 50      | 30      | 100     |
| 234    | 70                             | 119        | 96         | 39         | 0       | 0       | 105     |
| 235    | 70                             | 110        | 90         | 32         | 135     | 85      | -160    |
| 236    | 70                             | 100        | 52         | 26         | -170    | 5       | 70      |
| 242    | 70                             | 100        | 52         | 26         | -170    | 5       | 70      |
| 247    | 70                             | 100        | 52         | 26         | -170    | 5       | 70      |
| 248    | 70                             | 185        | 158        | 30         | 115     | 20      | 90      |
| 400    | 70                             | 100        | 52         | 26         | -170    | 5       | 70      |
| 600    | 60                             | 120        | 49         | 52         | 30      | 40      | 130     |
| 609    | 70                             | 245        | 60         | 33         | 100     | 90      | -155    |
| 610    | 60                             | 160        | 90         | 65         | 40      | 35      | 85      |
| 611    | 70                             | 130        | 105        | 67         | 80      | 20      | 75      |
| 623    | 70                             | 58         | 40         | 45         | 165     | 80      | -175    |
| 629    | 60                             | 190        | 50         | 130        | -150    | 60      | 70      |
| 630    | 70                             | 119        | 96         | 39         | 0       | 0       | 105     |
| 631    | 60                             | 140        | 80         | 42         | -70     | 110     | 85      |
| 637    | 50                             | 240        | 20         | 100        | 85      | 110     | 35      |
| 639    | 70                             | 115        | 75         | 35         | 170     | 35      | 115     |
| 640    | 60                             | 148        | 80         | 65         | 85      | 30      | -165    |
| 643    | 70                             | 220        | 70         | 38         | 95      | 100     | -175    |
| 644    | 70                             | 88         | 75         | 34         | -90     | 30      | -90     |
| 645    | 70                             | 95         | 67         | 35         | 165     | 70      | 155     |
| 646    | 70                             | 185        | 125        | 110        | 60      | 10      | 40      |
| 649    | 70                             | 170        | 75         | 55         | 30      | 70      | 160     |

**GOLD BAR PROJECT  
FORM 43-101F1 TECHNICAL REPORT – FEASIBILITY STUDY**

| Domain | % of Vario for Search Distance | Distance X | Distance Z | Distance X | Angle 1 | Angle 2 | Angle 3 |
|--------|--------------------------------|------------|------------|------------|---------|---------|---------|
| 650    | 70                             | 70         | 120        | 45         | 175     | 20      | 130     |
| 701    | WASTE                          |            |            |            |         |         |         |
| 711    | WASTE                          |            |            |            |         |         |         |
| 300    | WASTE                          |            |            |            |         |         |         |

**11.42 GOLD BAR SOUTH GRADE ESTIMATION**

With the sample set available, inverse distance (ID3) and ordinary kriging (OK) interpolation methods were used to estimate blocks within each domain using search distances derived from variography. A nearest neighbor (NN) model was also created from 20-foot composites using the same search orientations and distances as the OK and ID3 models for validation purposes. Blocks were also populated using the strike and dip of the contact, calculated on a 20-foot grid and a dynamic anisotropic (DA) model was calculated using ID3 and OK interpolation methods. Search parameters for the gold DA model were set to the same distances and number of samples as the traditional ID3 and OK models. A separate DA model was constructed for fault zones that appear to carry mineralization. The structural DA model was limited to 30-foot search radius of the structures used. The structural DA model was then merged with the stratigraphic DA model. Blocks from the structural DA model were given precedence over the stratigraphic model.

To preserve the gold grade relationship to source data and reduce smearing, a search neighborhood strategy with three search ellipse ranges was used. The first pass was limited to data close to the block at approximately 60-80% of the variogram range. Subsequent second and third search passes were increased in size by 2x the original distance and 2.2 times the original search distance. The search distances were adjusted by domain until the QP was satisfied that the blocks estimated represented an appropriate volume given the density of the source data and distance from mapped structures. Block grades on subsequent search passes were not allowed to overwrite previous estimates.

For each interpolation run, hard and soft boundaries were applied to test domain boundaries that produced ambiguous results from boundary condition testing. Comparison of the final models to the NN model showed that the soft boundary models and domains that were combined across structural or stratigraphic contact were lower in grade. This was due to the influence of lower grade material that typically occurs on one side of the boundary condition.

The ID3 DA model was chosen as the final model method after comparison to OK and NN models. Kriging appeared to overly smooth the domains in areas where mineralization was limited to narrow structural control while the ID model more heavily weighted the samples at short distances. The DA model best fits the grades to the overall shape of the contact zone and limits spreading grades outside of the brecciated zones.

**11.43 GOLD BAR SOUTH MINERAL RESOURCE CLASSIFICATION**

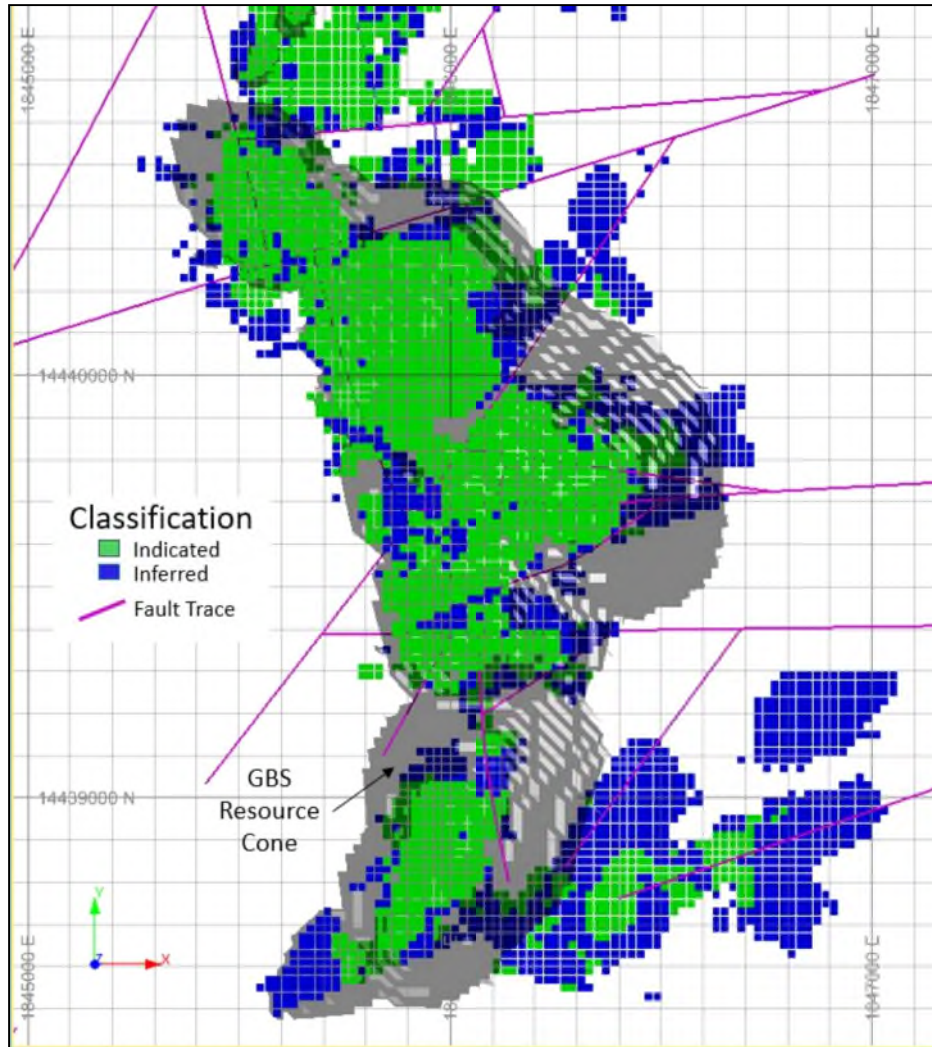
Mineral Resources were classified into Measured, Indicated, and Inferred categories based on based on CIM Definition Standards. Parameters used for classification are listed in Table 11-23. Parameters for measured are not included as those blocks were reclassified as indicated.

**Table 11-23: Gold Bar South Classification Parameters (McEwen, 2020)**

|                               | Indicated | Inferred |
|-------------------------------|-----------|----------|
| Block Model Code              | 2         | 3        |
| Average Distance              | ≤75       | ≤150     |
| Minimum Number of Drill holes | 3         | 2        |
| Minimum Number of Samples     | 5         | 3        |

Classification using a purely statistical approach occasionally produces artifacts—blocks that fail mathematical criteria but are clearly related to adjacent blocks. Again, Measured blocks were then reclassified as Indicated based on ongoing work to determine density values and mineralogy that could potentially affect recovery.

An oblique view of model blocks with Au > 0.005 opt showing the distribution of Indicated (green) and Inferred (blue) categories is provided Figure 11-48.



**Figure 11-48: Gold Ridge Estimated Blocks Colored by Classification Code (McEwen, 2020)**

#### **11.44 GOLD BAR SOUTH BLOCK MODEL VALIDATION**

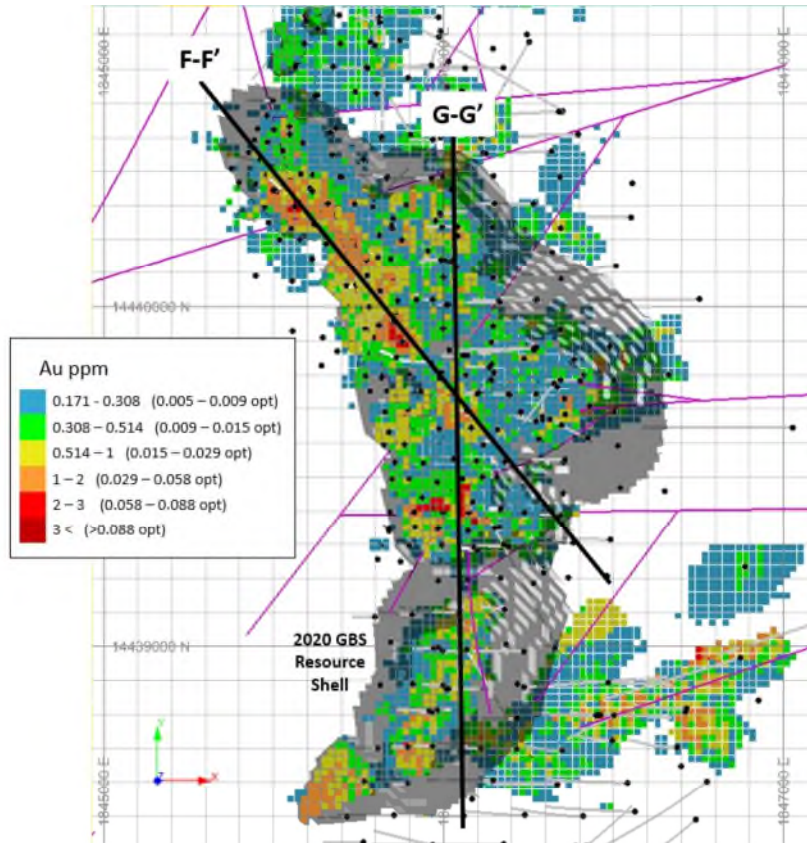
Various measures were implemented to validate the Gold Bar South block model. These measures included the following:

- Comparison of drill hole composites with resource block grade estimates from all zones visually in plan and section view;
- Statistical comparisons between block and composite data using distribution analysis;
- Statistical comparisons between the IDW, OK and NN models; and

- Swath plot analysis (drift analysis) comparing the inverse distance model with the NN model and declustered composite grades.

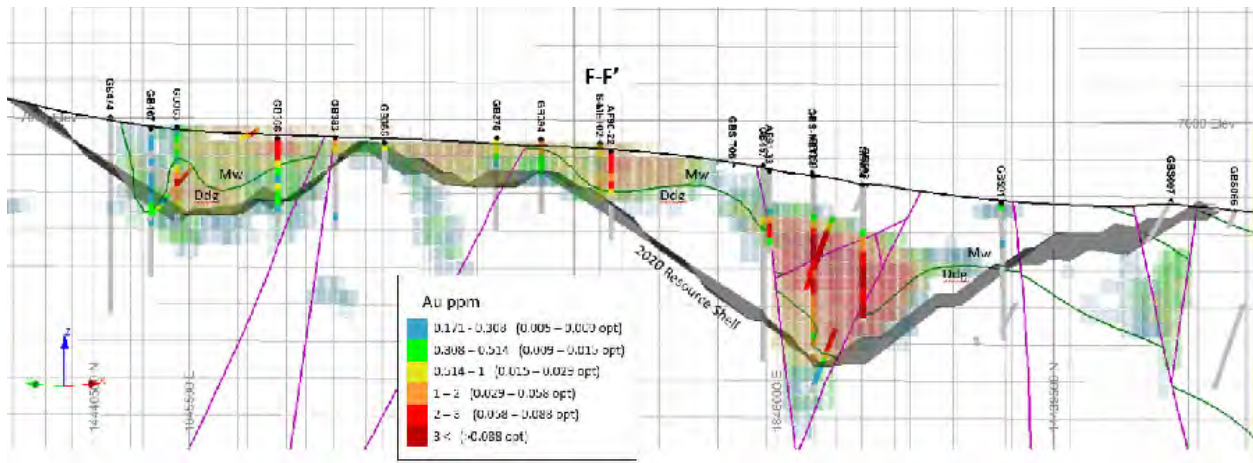
**11.44.1 Visual Comparison**

The estimated values of resource model block grades visually compare satisfactorily with composite values. Figure 11-49 provides a plan view of the resource pit and defines the locations of the cross sections. Figure 11-50 provides cross sections showing the blocks colored by the IDW estimated Au oz/t values and the corresponding composite grades for drill hole intervals within 40 ft of the cross section. The purple lines represent faulting. Gray ribbon represents the 2020 \$1750 resource shell.



**Figure 11-49: Plan View of Visual Validation Cross Section Locations for Estimated Grades (McEwen, 2020)**





**Figure 11-50: Section F-F' – Visual Validation of Estimated Gold Grades( McEwen, 2020)**

### 11.44.2 Visual Validation and Comparative Statistics

The model was validated visually in plan and section views comparing drill hole composites to adjacent block grades.

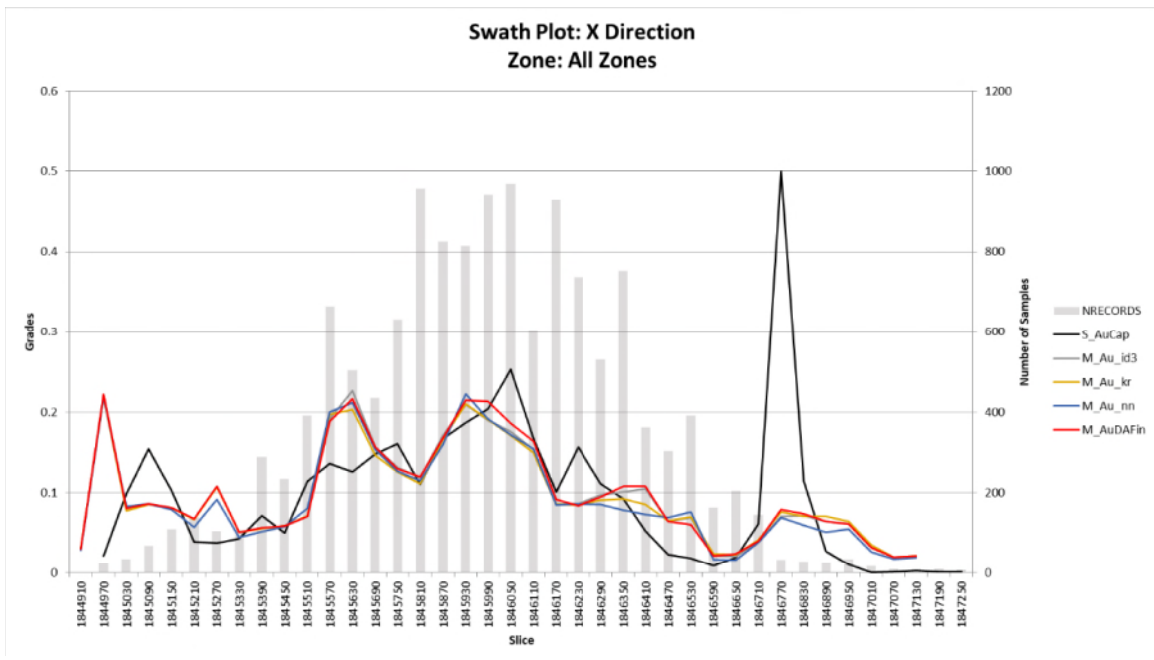
The interpolated OK and IDW gold grades using variography derived search ellipsoids and dynamic anisotropy (hard boundary and soft boundary models) were compared to both the underlying composite grades and declustered composites as well as the corresponding NN grades to ensure that the final grades estimates were valid. When comparing the OK and IDW estimate to the composite grades, it is important that the final average estimated grade be lower than the composite grades to ensure that metal is not “manufactured” during estimation. Inclusion of the NN grades computed from 20’ composites is an additional check on the interpolated grades. To ensure that these grade relationships were honored during the grade estimation process. Overall, interpolated grades are lower than composite grades and fit well with most domains. Where domains were combined across the stratigraphic contact, the overall grades interpolated are lower due to added dilution. Based on the results of the validation, future models should treat the contact as a hard boundary.

#### 11.44.2.1 Swath Plots

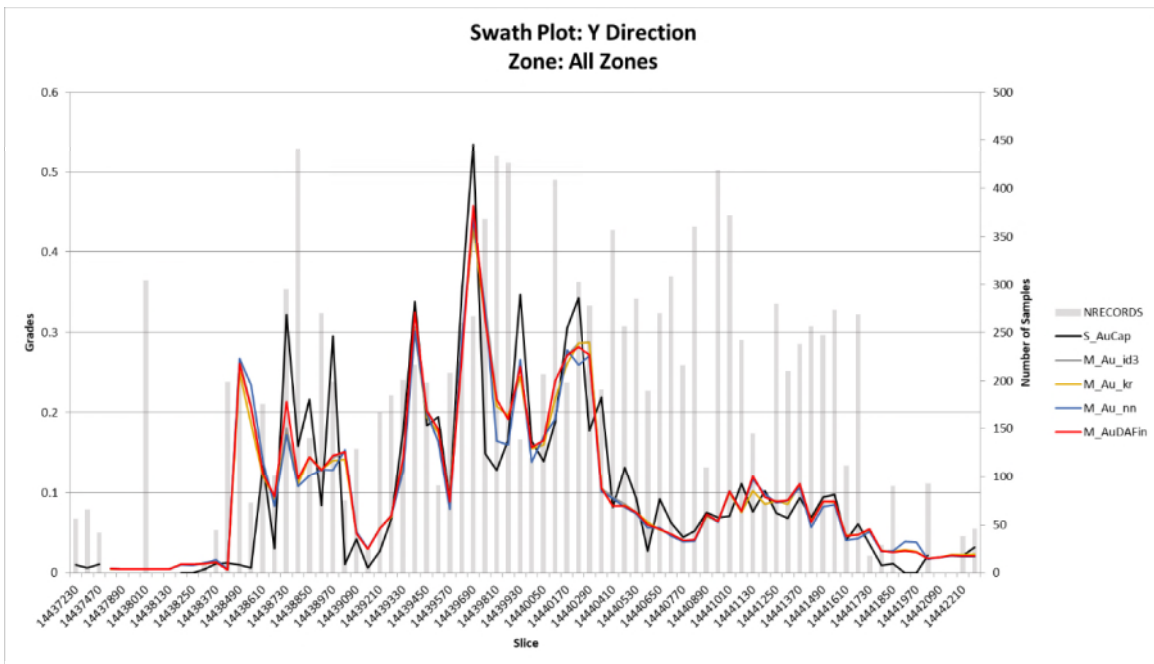
Using the swath plot, grade variations from the OK, IDW and NN models are compared to the distribution derived from the declustered composite dataset.

The grade trends may show local fluctuations on a swath plot, but the overall trend of the interpolated grades should be similar to the declustered composites. Swath plots were generated for gold grades along east-west and north-south directions, and elevation for the global model and individual domains. Swath widths were 60, 60, and 40 ft wide for east-west, north-south and elevation, respectively. Items plotted include Au grades by OK, IDW (hard and soft boundary models) and NN for all estimated blocks as well as the corresponding declustered composites (capped prior to compositing) Au grades. The swath plots are shown in Figure 11-51 through Figure 11-53.

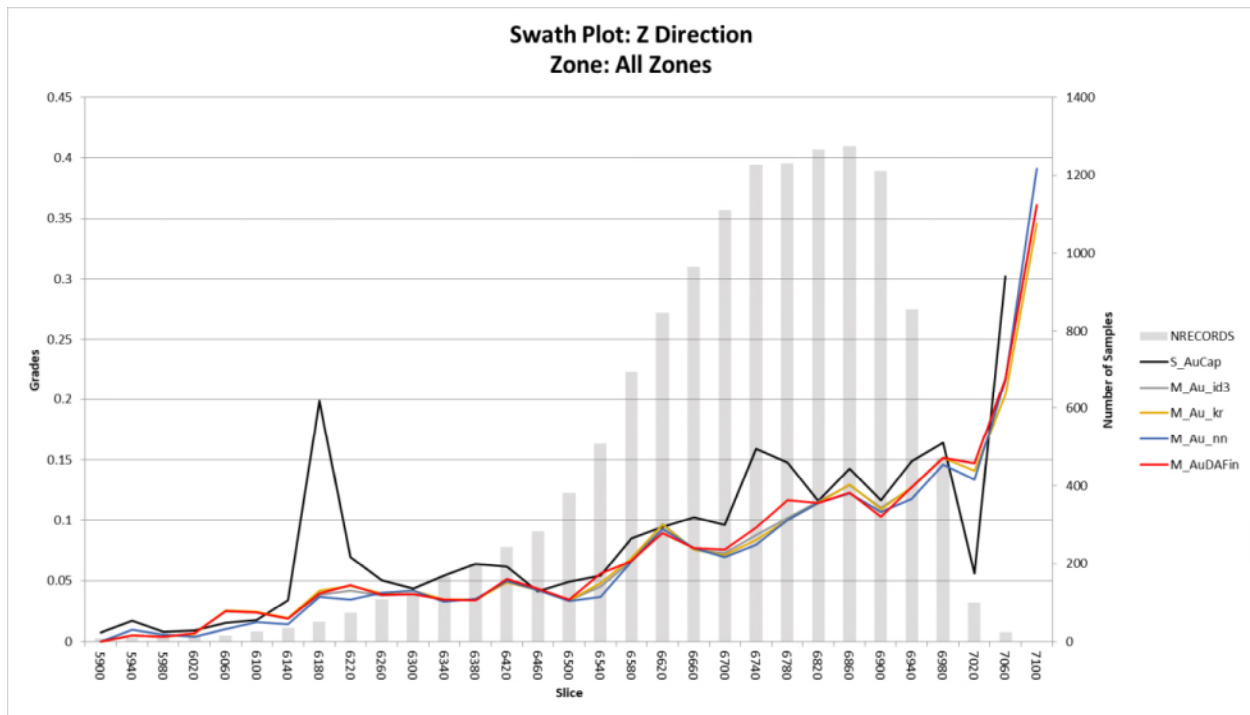
According to the swath plots, there is good correlation between the OK and ID methods utilizing hard boundaries and the NN method with the composites used. While there is a certain amount of smoothing that occurs around the peaks and valleys and in areas with lower block counts, overall, the models fit well with the composite dataset. The models interpolated using soft domain boundaries show more smoothing in the high- and low-grade ranges.



**Figure 11-51: North-South Au Swath Plot – 60 ft Eastings (McEwen, 2020)**



**Figure 11-52: East-West Au Swath Plot – 60 ft Northings (McEwen, 2020)**



**Figure 11-53: Elevation Au Swath Plot – 40 ft Elevations (McEwen, 2020)**

#### 11.45 GOLD BAR SOUTH ECONOMIC INPUT PARAMETERS

Cut-off grade for the Mineral Resource Statement was determined based on the following equation:

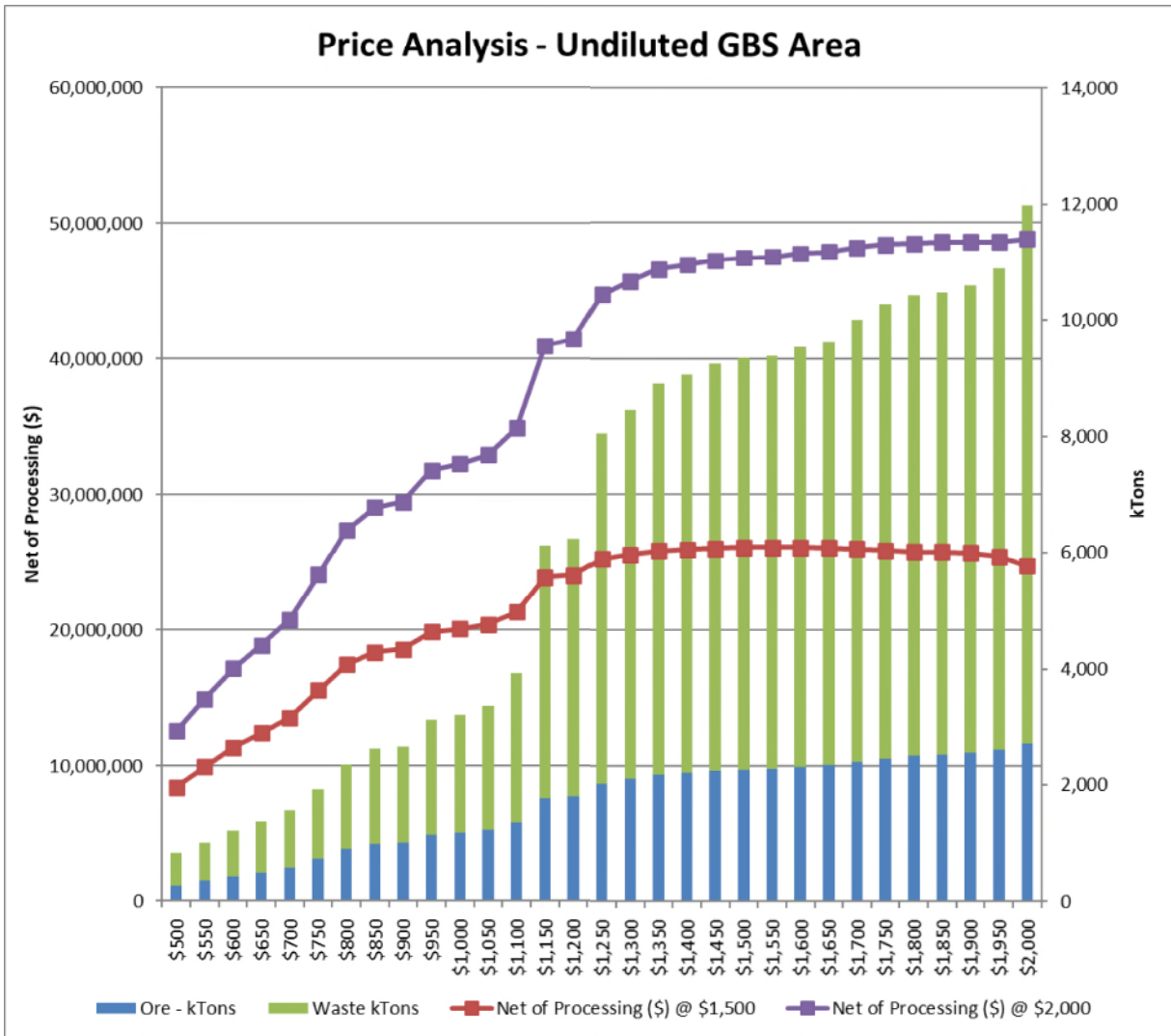
$$\text{Cut-off} = ((1+\text{DIL}) * (\text{MCo} + \text{PC} + \text{SR} + \text{R})) / (\text{Price} * \text{Rec} * \text{Factor})$$

- DIL = Dilution: 0 for the resource
- MCo = Mining Cost: US\$3.19/t for ore, US\$1.99/t for waste
- PC = Total Ore Processing Cost: US\$8.13/t (combined ROM and stacked ore)
- Price = Net Gold Sales Price: US\$1,725/oz
- Rec = Recovery: 61% ROM
- SR=Smelting and Refining: \$2.013/oz
- R=Royalty: 1% Net Smelter Return
- Factor = Factor for unit conversion: 1

The resulting cut-off grade for Gold Bar South rounds to 0.008 oz/t Au.

#### 11.46 GOLD BAR SOUTH MINERAL RESOURCE SENSITIVITY

The Gold Bar Mineral Resource is reported below at variable prices within the 2020 Resource Pit to demonstrate the sensitivity of the resource. The sensitivity analysis was completed using 0.009 oz/ton Au cut-off grade (\$1500/oz Au price) and 0.0067 oz/ton Au cut-off grade (\$2000/oz Au price). These sensitivities are provided in Figure 11-54 for undiluted resource.



**Figure 11-54: Gold Bar South Sensitivity Within the Resource Pit (McEwen, 2020)**

**11.47 MINERAL RESOURCE STATEMENT**

The four resource models were constrained with LG pit optimizations to ensure that the resource has a reasonable stripping ratio and meets the NI 43-101 criteria of having a reasonable potential for eventual economic extraction. Hexagon's MineSight software was used to generate an LG pit optimization using the economic inputs described in the footnotes of the resource statement. The combined Mineral Resource Statement for the Gold Bar Project, including Gold Pick, Gold Ridge, Cabin and Gold Bar South, is presented in Table 11-24.

**Table 11-24: Mineral Resource Statement (exclusive of Mineral Reserves) for the combined Gold Bar Gold Deposit, Eureka County, Nevada, USA, Effective 1 January, 2022.**

| Pit            | Classification | Mass (Ktons) | Grade (Au opt) | Contained Metal (Au (koz)) |
|----------------|----------------|--------------|----------------|----------------------------|
| All            | Indicated      | 1,479        | 0.056          | 82.4                       |
|                | Inferred       | 1,955        | 0.023          | 44.4                       |
| Pick           | Indicated      | 362          | 0.154          | 55.6                       |
|                | Inferred       | 842          | 0.022          | 18.9                       |
| Ridge          | Indicated      | 334          | 0.027          | 9.0                        |
|                | Inferred       | 751          | 0.019          | 14.3                       |
| Cabin          | Indicated      | 420          | 0.024          | 9.9                        |
|                | Inferred       | 0            | 0              | 0                          |
| Gold Bar South | Indicated      | 364          | 0.022          | 7.9                        |
|                | Inferred       | 362          | 0.031          | 11.2                       |

- The Mineral Resource was prepared under the direction of Michael Bauman, RM SME and C.P.G. Mr. Baumann is a Qualified Person (QP) under S-K 1300 who takes responsibility for it.
- Mineral Resources do not have demonstrated economic viability. The estimate of Mineral Resources may be materially affected by environmental, permitting, legal, title, taxation, socio-political, marketing, or other relevant issues.
- Mineral resources are based on the following economic input parameters: \$3.19/ore ton mining cost, \$1.99/waste tone mining cost, \$4.91/ore ton crushed process cost, \$3.77/ore ton ROM process cost, \$3.16/ore ton G&A cost, \$0.475/toz gold refining charge, \$1.538/toz transport & sales cost, 99.95% payable gold, 1% royalty at GBS only, 78% crushed oxide recovery at Pick & Ridge, 50% mid-carbon recovery at Pick & Ridge, 72% ROM oxide recovery at Pick & Ridge, 61% ROM oxide recovery at GBS, 0% ROM mid-carbon recovery
- The stated Resources above are based on a variable cut-off grade based on rock type, mining area, carbon content, clay content, and process response.
- Resources stated in the table above are contained within a \$1,725/oz Gold sales price Lerchs-Grossmann (LG) pits.
- ktons means 1000 short tons; Short tons = 2000 lbs.
- Gold is reported in Troy Ounces per Short Ton
- Based on end of December 2021 topography
- The Mineral Resources in this report were estimated and reported using the regulation S-K 1300 of the United States Securities and Exchange Commission ("SEC").

#### **11.48 POTENTIAL RISKS IN DEVELOPING THE MINERAL RESOURCE**

McEwen is not aware of any environmental, permitting, legal, title, taxation, socio-economic, marketing, political or other issues that could materially affect the mineral resources stated here. Additional core drilling, permitting, engineering and cost estimating are necessary to convert the remaining Inferred Mineral Resources at Gold Ridge, Cabin and Gold Bar South to Mineral Reserves.

Assay grades are expected to be confirmed with additional planned core drilling. Density data is a current deficiency, but the estimate presented here should be accurate to +/- 5%, which is within the tolerance of the resource estimate.

Since Gold Bar is a producing mine, there are moderate to low risks to the continued development of the mineral resource at the site as follows in

**Table 11-25.**

**Table 11-25: Risks by Category**

| <b>Risk Category</b> | <b>Explanation</b>   | <b>Risk</b> |
|----------------------|--|-------------|
| Geology              | Uncertainty in geological interpretation may affect mineral estimates in areas that have not been mined.   | Moderate    |
| Estimation           | Bulk Density: bulk density is assigned on a rock type basis, based on the median measured bulk density. Local variations in density may affect tonnage results.  | Moderate    |
|                      | Uncertainty in geological interpretation may affect mineral estimates in areas that have not been mined.   | Moderate    |
|                      | Outlier Management: grade capping is used to limit the influence of anomalous high-grade samples on a vein basis. Local grade trends may therefore be biased.  | Low         |
| Metallurgy           | Data to assist in the estimation of recoveries, such as the presence of carbon and oxidation state are limited in areal. Local variations in recovery may affect recoveries.   | Moderate    |
| Data                 | Data Management: all information is stored in a proprietary SQL database. Mineral resources are calculated for each deposit in Datamine Studio RM software or Minesite 3D. Data validation errors may contribute to estimation errors. | Low         |
| Reconciliation       | Detailed block model reconciliation has not historically been carried out on a routine basis. This is important to continue to identify critical errors in the models.   | Moderate    |

## **12 MINERAL RESERVE ESTIMATES**

The mineral reserve was developed from the block model and is the total of all proven and probable category ore that is planned for processing. The mine plan that is presented in Section 13 details the development of that mine plan. The mineral reserve was established by tabulating the contained tonnage of measured and indicated material (proven and probable) within the designed final pit geometry at the planned cut-off grade. The final pit design and the internal phase (pushback) designs were guided by the results of the Lerchs-Grossmann algorithm.

### **12.1 RESERVE ESTIMATION**

#### **12.1.1 Economic Pit Shells**

The Lerchs-Grossmann (LG) algorithm is a tool for guidance to mine design that targets an economical pit shell. The algorithm applies approximate costs and recoveries along with approximate pit slope angles to establish theoretical economic breakeven pit wall locations. All the LG and mine plan discussions in this section and the subsequent sections address Measured and Indicated (Proven and Probable) ore only. Inferred is treated as waste from this point forward in the project evaluation. The Project was built in U.S. units and all metal grades are in troy ounces per short ton (oz/t).

Economic input applied to the LG algorithm is necessarily preliminary as it is one of the first steps in the development of the mine plan. However, the LG geometries should be considered as approximate as they do not assure access, working room or address geotechnical constraints. The important result of the LG's is the relative changes in geometry between LG's of increasing metal prices. Lower metal prices result in smaller pits which provide guidance to the design of the initial pushbacks. The change in pit geometry as metal prices are increased indicates the best directions for the succeeding phase expansions to the ultimate pit.

Table 12-1 summarizes the input data to the LG's. Process recoveries and estimated process costs were provided by Forte and the MUX project team. The overall slope parameters at Pick and Ridge are based on the 2012 geotechnical report by SRK, 2012 PFS (SRK, 2012a, SRK, 2012b) provided by McEwen to IMC. The overall slope parameters at Gold Bar South are based on geotechnical report by Piteau, "Mine Planning Summary of Recommended Geotechnical Slope Designs for Gold Bar South Mine Plan" (Piteau, 2020) provided by McEwen to IMC. The slope angles used for Pick in the LG algorithm are consistent with pre-existing pit walls that were observed during an IMC site visit and confirmed by current operators at site. Mine operating costs were derived from contractor mining quotes provided to McEwen and subsequently provided to IMC by McEwen.

Table 12-1: Economic Input Parameters (IMC, 2022)

**Mining Cost**

| <b><u>Ore Mine Operating Cost</u></b>   |                      | <b><u>Mining Cost</u></b> | <b><u>Incremental Haul Cost</u></b>     |
|---|----------------------|---------------------------|---|
|   | Pick                 | \$3.29 /ore ton           | \$0.00 /ore ton                         |
|   | Cabin                | \$3.29 /ore ton           | \$0.00 /ore ton                         |
|   | Ridge                | \$4.16 /ore ton           | \$0.00 /ore ton                         |
|   | Gold Bar South (GBS) | \$3.57 /ore ton           | \$0.00 /ore ton                         |
| <i>Based on recent contractor bid</i>   |                      |                           |   |
| <b><u>Waste Mine Operating Cost</u></b> |                      | <b><u>Mining Cost</u></b> | <b><u>Incremental Ore Haul Cost</u></b> |
|   | Pick                 | \$2.57 /waste ton         | \$0.72 /waste ton                       |
|   | Cabin                | \$2.57 /waste ton         | \$0.72 /waste ton                       |
|   | Ridge                | \$2.31 /waste ton         | \$1.85 /waste ton                       |
|   | Gold Bar South (GBS) | \$2.14 /waste ton         | \$1.43 /waste ton                       |
| <i>Based on recent contractor bid</i>   |                      |                           |   |

**Processing and G&A Cost (Reserves Target Crusher + Stack | Resources Target ROM + Stack)**

|                           |       | <b><u>Process Cost</u></b> | <b><u>G&amp;A</u></b> | <b><u>Ore Haul Increment</u></b> | <b><u>Total</u></b> |
|---------------------------|-------|----------------------------|-----------------------|----------------------------------|---------------------|
| <b><u>Mining Area</u></b> |       |                            |                       |                                  |                     |
| <b>Crusher +Stack</b>     | Pick  | \$4.91                     | \$3.22                | \$0.72                           | \$8.85 /ton ore     |
|                           | Cabin | \$4.91                     | \$3.22                | \$0.72                           | \$8.85 /ton ore     |
|                           | Ridge | \$4.91                     | \$3.22                | \$1.85                           | \$9.98 /ton ore     |
|                           | GBS   | \$4.91                     | \$3.22                | \$1.43                           | \$9.56 /ton ore     |
| <b>ROM +Stack</b>         | Pick  | \$3.77                     | \$3.22                | \$0.72                           | \$7.71 /ton ore     |
|                           | Cabin | \$3.77                     | \$3.22                | \$0.72                           | \$7.71 /ton ore     |
|                           | Ridge | \$3.77                     | \$3.22                | \$1.85                           | \$8.84 /ton ore     |
|                           | GBS   | \$3.77                     | \$3.22                | \$1.43                           | \$8.42 /ton ore     |

**Process Recovery**

|                           |       | <b><u>Oxide / High Clay</u></b> | <b><u>Mid-Carbon / Low Rec.</u></b> |
|---------------------------|-------|---------------------------------|-------------------------------------|
| <b><u>Mining Area</u></b> |       |                                 |                                     |
| <b>Crusher +Stack</b>     | Pick  | 78%                             | 50%                                 |
|                           | Cabin | 78%                             | 50%                                 |
|                           | Ridge | 78%                             | 50%                                 |
|                           | GBS   | N/A                             | N/A                                 |
| <b>ROM +Stack</b>         | Pick  | 72%                             | 0%                                  |
|                           | Cabin | 72%                             | 0%                                  |
|                           | Ridge | 72%                             | 0%                                  |
|                           | GBS   | 61%                             | 0%                                  |

\* All GBS is to be ROM



Table 12-2: Economic Input Parameters (IMC, 2021)

Smelting and Refining Terms

|                                 |  |                |
|---------------------------------|--|----------------|
| <b>Gold Refining</b>            | \$0.475  | /oz Gold       |
| <b>Transport and Sales Cost</b> | \$1.538  | /oz Gold       |
| <b>Payable Gold</b>             | 99.95%   |                |
| <b>Royalty</b>                  | <u>Mining Area</u>   | <u>Royalty</u> |
|                                 | Pick   | 0.00%          |
|                                 | Cabin  | 0.00%          |
|                                 | Cabin NPI  | 4.00%          |
|                                 | Ridge  | 0.00%          |
|                                 | GBS  | 1.00%          |
| <b>Dilution</b>                 | IMC built in a mining dilution at Pick and Ridge based on the grade of the surrounding blocks. |                |

Metal Prices for Base Case

|                   |          |          |
|-------------------|----------|----------|
| <b>Gold Price</b> | \$ 1,650 | /troy oz |
|-------------------|----------|----------|

Slope angles, Less 4 Degrees for Roads

| <u>Mining Area</u> | <u>Azimuth</u> |      | <u>Overall</u> | <u>Interramp</u> |
|--------------------|----------------|------|----------------|------------------|
|                    | (From)         | (To) | (Degrees)      | (Degrees)        |
| Pick - West        | 0              | 360  | 50             | 54               |
| Cabin              | 0              | 360  | 50             | 54               |
| Ridge              | 0              | 360  | 42             | 42               |
| GBS                | Varied         |      | Varied         |                  |

Cut-off Grades by Area & Process Type

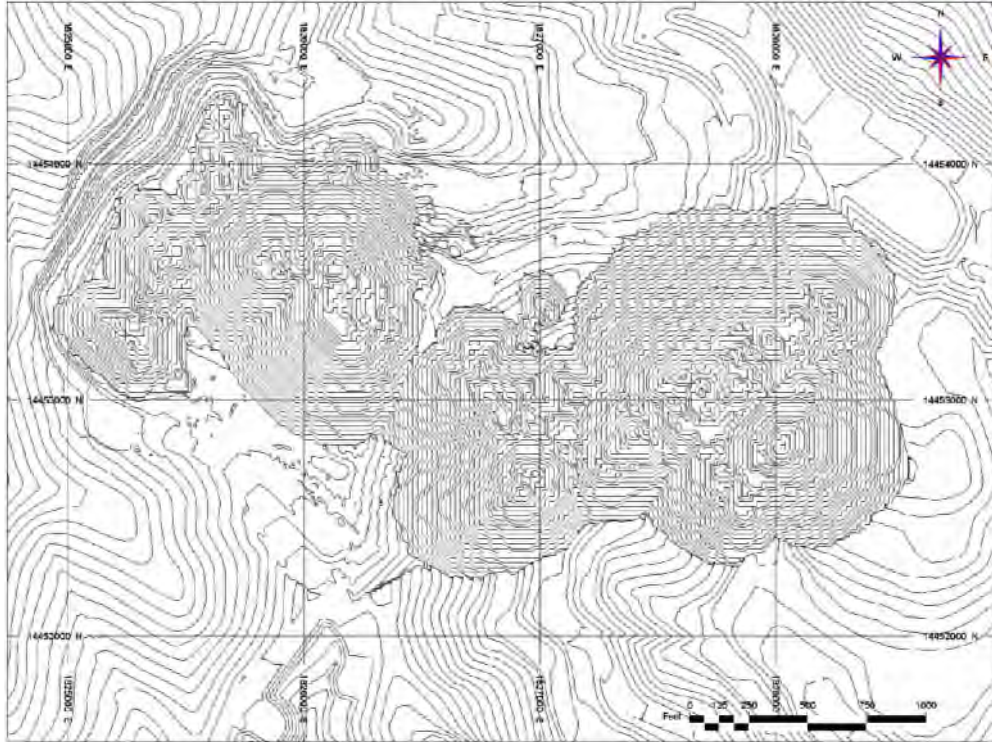
| Internal Cut-off Grades (oz/ton) |          |                   |                              |                  |
|----------------------------------|----------|-------------------|------------------------------|------------------|
| <u>Mining Area</u>               | ROM Only | To Crusher        |                              |                  |
|                                  |          | <u>Oxide Only</u> | <u>Mid-Carbon / Low Rec.</u> | <u>High Clay</u> |
| Pick                             | 0.0065   | 0.0300            | 0.0107                       | 0.0069           |
| Ridge                            | 0.0075   | 0.0300            | 0.0121                       | 0.0078           |
| GBS                              | 0.0085   | N/A               | N/A                          | N/A              |

The final pit design is based on a breakeven economic LG target pits between \$1250/oz & \$1400/oz gold price. The metal within the designed pit was then tabulated using a \$1,650/oz gold price to maximize the return on investment. The final pit designs were not optimized to the increased gold price of \$1,650/oz gold. The LG pit targets were selected based on a price sensitivity that resulted in the best project returns while minimizing the risks associated with minimal project contribution. An area that had minimal incremental project benefit from the \$1250 to \$1400 LG pits, might have resulted in committing to mining a much larger pit and therefore the smaller pit target was selected.

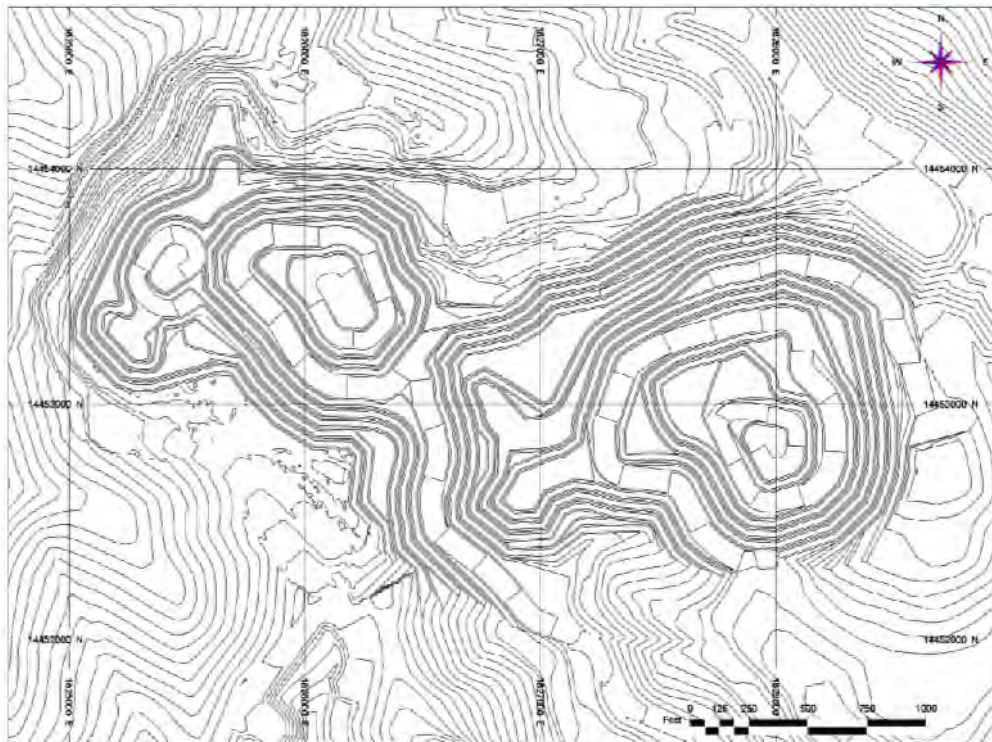
In consultation with the geological modeler, an additional mining dilution grade was developed by IMC for Pick, Ridge and Cabin model areas. A mining dilution was not applied to GBS, because additional dilution was already built into the model at GBS. Several methods for developing mining dilution were evaluated and compared with ore control. The dilution method that resulted in the closest correlation to ore control calculated the diluted mining grade by diluting every block with 50% of the non-diluted grade in each of surrounding blocks on a bench.

Figure 12-1, Figure 12-3, and Figure 12-5 illustrate the target LG pit that was used as the guide for final pit design in Gold Pick, Gold Ridge and Gold Bar South respectively.

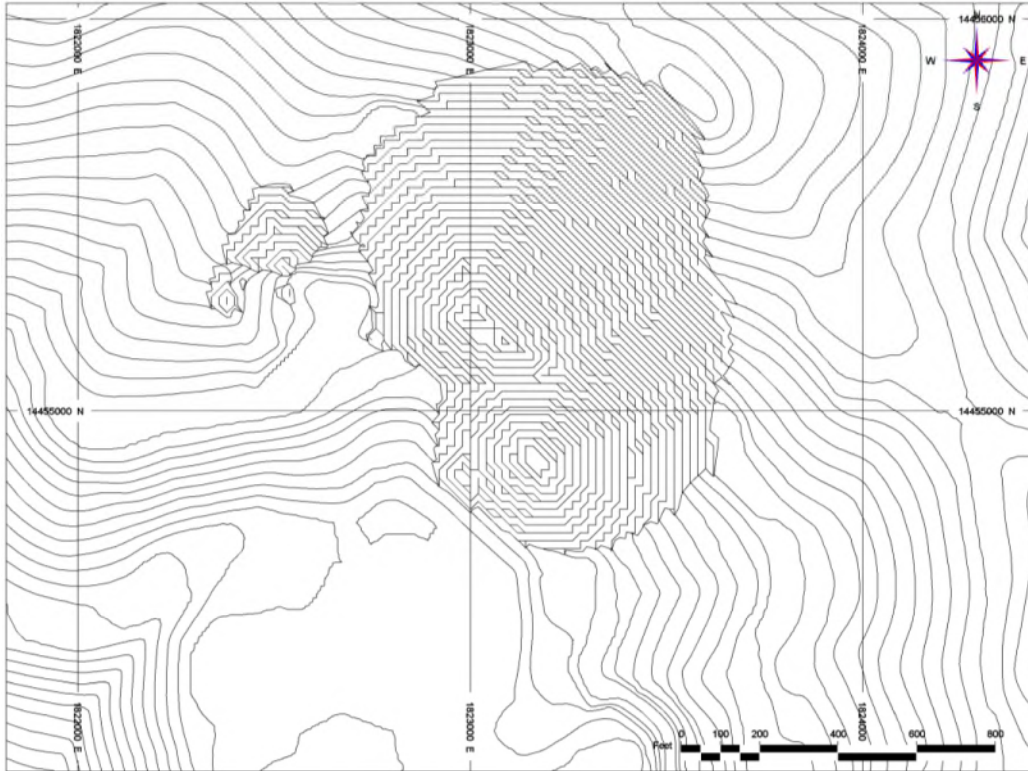
Figure 12-2, Figure 12-4, and Figure 12-6 illustrate the final pit designs guided the LG targets in Gold Pick, Gold Ridge and Gold Bar South respectively.



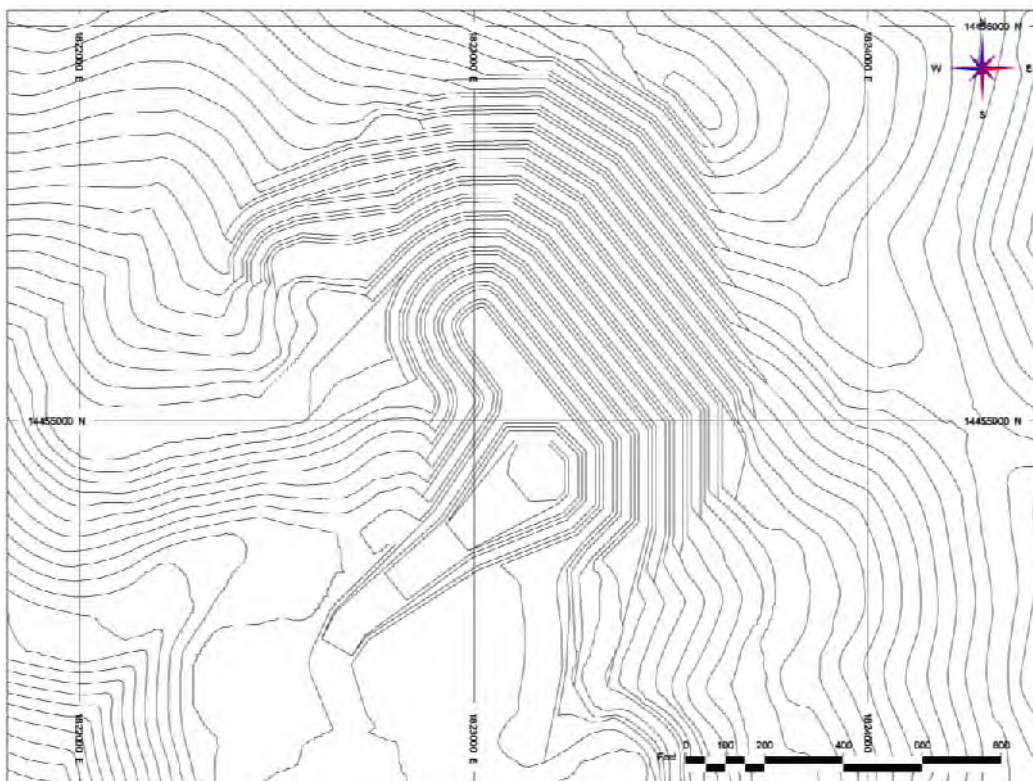
**Figure 12-1: Gold Pick – LG Output (IMC, 2020)**



**Figure 12-2: Gold Pick – Phase Design (IMC, 2020)**



**Figure 12-3: Gold Ridge – LG Output (IMC, 2020)**



**Figure 12-4: Gold Ridge – Phase Design (IMC, 2020)**

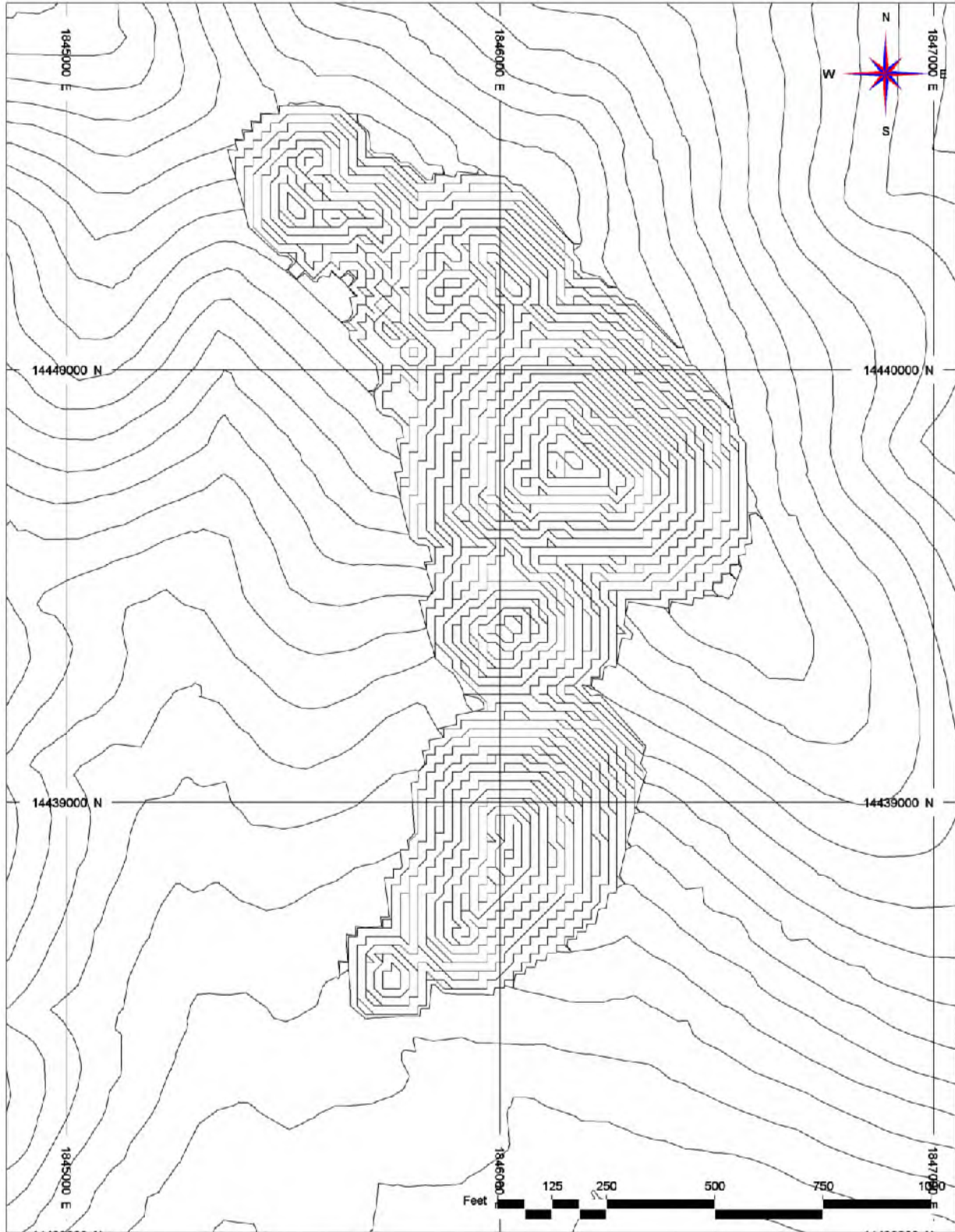
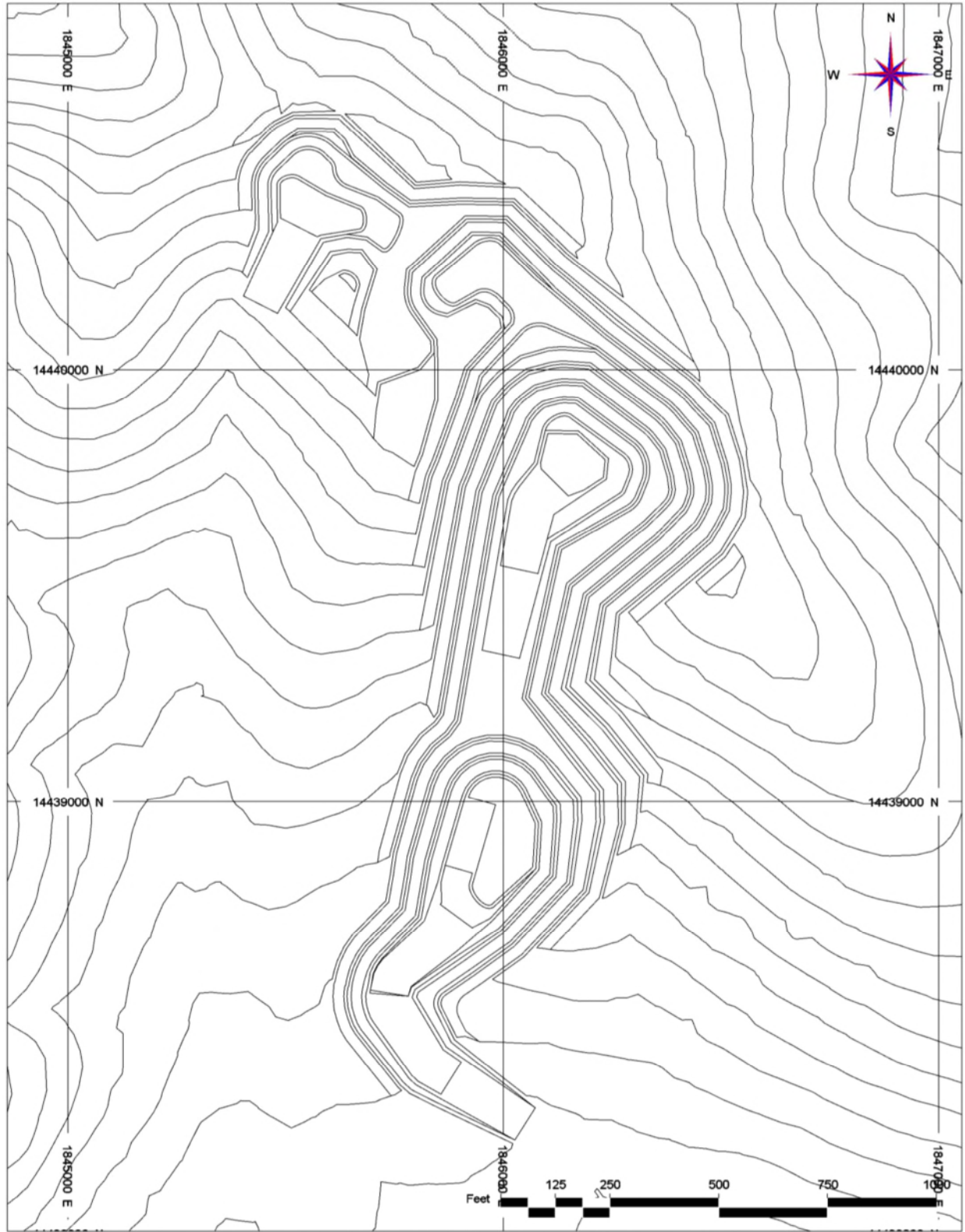


Figure 12-5: Gold Bar South – LG Output (IMC, 2020)



**Figure 12-6: Gold Bar South – Phase Design (IMC, 2020)**

### **12.1.2 Final Pit Design**

The final pit designs are based on the breakeven economic LG pits between \$1,250/oz & \$1,400/oz gold grade to maximize the return on investment. The designed pits are then tabulated using a \$1,650/oz gold price. The LG algorithm targets several ore pods creating multiple unique pit bottoms. The resulting LG pits contain several noses, peaks and saddles, which create geotechnical and access issues, see Figure 12-5. The final design, shown in Figure 12-6 merged the pit bottoms and removed geotechnical features to produce a minable pit design. As a result, the final pit design is larger than LG pit targets.

The final pit design is split into three mining areas that are planned for the production of the Gold Bar deposit. Access roads and working room for the equipment have been planned into the phase designs. The inter-ramp slope angles that were recommended by SRK and Piteau have been used for the final pit design.

The following criteria were applied to the final pit and phase designs:

|                                   |                      |
|-----------------------------------|----------------------|
| Mine Planning Parameters:         |                      |
| Haul Road Width                   | 88 feet              |
| Haul Road Grade                   | 10% Maximum          |
| Inter-ramp Slope Angles           | Inter-ramp           |
| Gold Pick                         | 54 degrees           |
| Gold Bar South                    | 38-45 degrees        |
| Gold Ridge                        | 42 degrees           |
| Operating width between pushbacks | 200-300 feet nominal |

The final pit design inclusive of haul roads is illustrated on Figure 12-2. Additional mine plan drawings will be provided in Section 13 with the discussion of the mine plan and operation.

Section 11 reported that the block model is based on 20 by 20 ft blocks with a 20 ft bench height. The planned equipment at Gold Bar will be a good match for the 20ft bench height. Block model grades were utilized to develop the mine plan. The block model was developed by MUX and is discussed in Section 11.

The mine plan assumes that the mine operator will be able to selectively mine the ore zones. The model has estimated carbonaceous, sulfidic, and high clay zones that are known to impact recoveries. Adjustments to the modeled carbonaceous, sulfidic, and high clay zones could have positive or negative impacts to the project. It is crucial that alteration that may be present in the ore zones be correctly identified and segregated when mining. It is understood that the visual identification of the carbon alteration zones can be assessed in the field. The carbonaceous zones have a distinctive black coloration that allow it to be identified from non-carbonaceous zones. However, black coloration does not necessarily mean the carbon is activated and will affect processing. Analytical testing will be conducted for final ore/waste designation of carbonaceous material prior to mining. Sulfide is difficult to determine by visual assessment and analytical testing will be conducted before material is classified as ore.

## **12.2 RESERVE ESTIMATE**

The Gold Bar mine open pit Mineral Reserve Statement is presented in Table 12-3.

**Table 12-3: McEwen Mining Inc. – Gold Bar Deposit Mineral Reserve Statement (Imperial Units);  
Independent Mining Consultants, January 1, 2022**

| Classification           | Cut-off Grade (oz/t) | Mineralized Tons (ktons) | Gold Grade                  |                             | Gold Metal                     |                                |
|--------------------------|----------------------|--------------------------|-----------------------------|-----------------------------|--------------------------------|--------------------------------|
|                          |                      |                          | Contained Gold Grade (oz/t) | Recovered Gold Grade (oz/t) | Contained Metal (000's ounces) | Recovered Metal (000's ounces) |
| Probable                 | Variable             | 15,491                   | 0.024                       | 0.017                       | 370                            | 260                            |
| <b>Total Prov + Prob</b> |                      | 15,491                   | 0.024                       | 0.017                       | 370                            | 260                            |

Notes:

- The Mineral Reserve was provided by Independent Mining Consultants, Inc. (IMC), an independent third-party contractor.
- Based on IMC's knowledge there are no environmental, permitting, legal, title, taxation, socio-economic political issues that would materially affect these Mineral Reserves.
- Mineral Reserves equal the total ore planned for processing as of January 1st, 2022 from the mine plan based on a \$1,650/oz gold
- Mineral reserves are based on the following economic input parameters: \$3.80/ avg. ore ton mining cost, \$2.88/ avg. waste ton mining cost, \$4.91/ore ton crushed process cost, \$3.77/ore ton ROM process cost, \$3.22/ore ton G&A cost, \$0.475/toz gold refining charge, \$1.538/toz transport & sales cost, 99.95% payable gold, 1% royalty at GBS only, 78% crushed oxide recovery at Pick & Ridge, 50% mid-carbon recovery at Pick & Ridge, 72% ROM oxide recovery at Pick & Ridge, 61% ROM oxide recovery at GBS, 0% ROM mid-carbon recovery. The stated Reserves above are based on a variable cut-off grade based on rock type, mining area, carbon content, clay content, and process response.
- Reserves stated in the table above are contained within an engineered pit design between the US\$1,250/oz, and \$1,400/oz Gold sales price Lerchs-Grossmann (LG) pits.
- The stated Mineral Reserves above are not additional to the Mineral Resource (Mineral Reserves are included in the Mineral Resources )
- 
- ktons means 1000 short tons; Short tons = 2000 lbs.
- Gold is reported in Troy Ounces per Short Ton
- Based on end of December 2021 topography
- The Mineral Resources in this report were estimated and reported using the regulation S-K §229.1304 of the United States Securities and Exchange Commission ("SEC").

### 12.3 CLASSIFICATION OF RESERVES

In accordance with regulation CRIRSCO and the CIM classification system only Measured and Indicated resource categories can be converted to reserves (through inclusion within the open-pit mining limits). In all Mineral Reserve statements, Inferred Mineral Resources are reported as waste. The Mineral Reserve is further limited by material that can be mined economically, which is identified by the cut-off grades (CoG's) associated with mineral extraction.

CoG is a function of technical and economical parameters and defines the economic portion of the resource at the time of determination. Break even CoG considers the total unit operating costs, including mining, processing and administration, process recovery, metal prices and additional costs for freight, smelting and/or refining. Where applicable, royalties are included in the calculation. A second CoG often used is the internal CoG that only considers any additional cost to mine ore beyond waste. This cut-off defines material that is uneconomic but has a lower final cost to the Project if processed rather than wasted.

Once such a CoG is defined all the material with a gold grade above this value should be considered as ore, i.e., economically mineable. Ore feed to plant will have an average grade higher than the CoG value, and this difference provides the profit (return on capital) for the business.

The CoG may be modified to other values during the mining operations to optimize business profits. These operational CoG grades may accomplish different specific purposes.

**12.3.1 Break Even Cut-off Grade**

The typical expression for a break-even (BE) gold CoG is (allowing for appropriate use of units):

$$\text{BE CoG} = \frac{\text{Total Unit Mining, Processing and Administration Operating Costs}}{(\text{Au Price} - (\text{Royalty} + \text{Final Sales Costs})) \times \text{Process Recovery}}$$

**12.3.2 Internal Cut-off Grade**

An alternative (operational) CoG, the internal CoG, considers all operating costs, but only includes the ore mining cost that exceeds the waste mining cost of that same block. This material is considered marginal and once it has been mined (for example to access ore with grades above the BE CoG) the mining cost is considered to be a sunk cost. The ore and waste haulage cost differ significantly and also vary by mining phase. An incremental ore haulage cost was applied to equalate the variation in haulage costs. If the material can pay for the additional ore mining cost, downstream processing costs, and other ore related costs then it qualifies as ore. This can be adjusted to allow for differential ore and waste haulage (or other) costs.

The typical expression for an internal (Int.) gold CoG is (allowing for appropriate use of units):

$$\text{Int. CoG} = \frac{\text{Total Unit Processing, Incremental Haulage and Administration Operating Costs}}{(\text{Au Price} - (\text{Royalty} + \text{Final Sales Costs})) \times \text{Process Recovery}}$$

The CoG used by IMC to determine whether a block was ore or waste was the internal cut-off reported as ounces per ton during the pit optimization process. A CoG was established for each mining area and planned type of processing to define ore and waste in the production schedule.

The ore recovery response was evaluated by Forte for each major ore type. The variable internal CoG applied is based on the best economics for each ore type, mining area, oxide, carbon content, recovery, or clay content. Lower grade material was shipped directly to the leach pad if it was only oxide ore (does not contain carbon or high clay). Higher grade material was shipped to the crusher when economic benefit from the increased recovery was greater than economic benefit from shipping the material as ROM only. Any material identified as either mid-carbon, lower recovery or containing a high clay content is to be shipped to the crusher prior to being placed on the leach pad. Material in the model identified as high carbon was not processed and is planned to be placed in a designated waste stockpile.

Depending on the orebody, the CoG can be adjusted to increase the project NPV. Multiple schedules and mining sequences were evaluated. The largest impact on the NPV was the mining sequence and type of processing applied to the ore. The NPV did not improve from elevating the CoG's. Consequently, it was determined that the project should be mined at an internal CoG between 0.0065 and 0.0121 oz/t Au. The internal CoG's applied to each mining area and processing type are reported in Table 12-4.

**Table 12-4: Internal Cut-off Grades (IMC, 2022)**

| Internal Cut-off Grades (oz/ton) |              |                   |                              |                  |
|----------------------------------|--------------|-------------------|------------------------------|------------------|
| Process:                         | ROM Only     | To Crusher        |                              |                  |
| <i>Mining Area</i>               | <i>Oxide</i> | <i>Oxide Only</i> | <i>Mid-Carbon / Low Rec.</i> | <i>High Clay</i> |
| Pick                             | 0.0065       | 0.0300            | 0.0107                       | 0.0069           |
| Ridge                            | 0.0075       | 0.0300            | 0.0121                       | 0.0078           |
| GBS                              | 0.0085       | N/A               | N/A                          | N/A              |



**12.4 RESERVE ESTIMATE RISKS**

IMC is not aware of any environmental, permitting, legal, title, taxation, socio-economic, marketing, political, or other issues that could materially affect the mineral reserves stated here.

**Table 12-5: Risks by Category**

| <b>Risk Category</b> | <b>Explanation</b>  | <b>Risk</b> |
|----------------------|---|-------------|
| Geology              | Uncertainty in geological interpretation may affect mineral estimates in areas that have not been mined.  | Moderate    |
|                      | Probable Mineral Reserves are at a lower confidence risk than Proven Mineral Reserves. Marginal Mineral Reserves are at a higher risk of being uneconomic than Economic Mineral Reserves.           | Low         |
|                      | Ore Control: Correctly identifying and segregating the various zones during mining activity will be a key factor impacting the project economics.   | Low         |
| Estimation           | Bulk Density: bulk density is assigned on a rock type basis, based on the median measured bulk density. Local variations in density may affect tonnage results.                                     | Moderate    |
|                      | Uncertainty in geological interpretation may affect mineral estimates in areas that have not been mined.  | Moderate    |
| Metallurgy           | Data to assist in the estimation of recoveries, such as the presence of carbon and oxidation state are limited in areal extent. Local variations in recovery may affect recoveries.                 | Low         |
|                      | Ability to selectively mine ore and waste may result in a higher than expected or a lower than expected dilution.   | Low         |
| Data                 | Data Management: all information is stored in a proprietary SQL database. Mineral resources are calculated for each deposit in Datamine. Small database errors may contribute to estimation errors. | Low         |
| Geotechnical         | Unexpected geotechnical conditions may result in the loss of ore.   | Low         |
|                      | Better than expected geotechnical conditions may allow steeper slopes, resulting in a higher ore recovery.  | Moderate    |
| Workforce            | Lack of a skilled work force, and supervision may result in higher costs and lower productivities.  | Low         |
| Economics            | Long term future higher cut-off values have the potential, and may, reduce Mineral Reserves tonnes and contained metal.   | Moderate    |

### **13 MINING METHODS**

The Gold Bar Project is planned for production using conventional hard rock open pit mining methods. Ore production to the crusher is planned at a maximum capacity of 7,500 tpd (2,750 ktons/yr). Additional run of mine (ROM) material will be placed when available. The maximum ore production to the leach pad (crushed & ROM) is planned to be 8,880 tpd (3,240 ktons/yr). The mine production schedule was developed with the goal of filling the crusher at the required ore rate and maximizing the project return on investment. The total material rate is tied to equipment productivity and fluctuates by period. The maximum total production is expected to reach a rate of 64,700 tons/day (23,600 ktons/yr). The mine is scheduled to operate 7 days/wk with two, 12-hour shifts/day.

The Gold Bar Project is currently being mined by a contractor, and this is planned to continue. Contractor equipment on hand is often variable. There is flexibility in the fleet size, and the actual mining fleet in use will likely vary depending on the contractor's fleet on hand. The schedule and production requirements were based on the following fleet assumptions: Bench heights are planned at 20-ft; drilling is planned based on using four rotary down-the-hole hammer drills with 45,000 lb pull down capacity and 6.75 in diameter blast holes; and the blasted rock will be loaded into 100-ton haul trucks using three, 16-cubic yard front-end loaders.

The mine plan was developed with a phased approach. The phase designs, mine schedule, and mine equipment requirements are summarized in this section.

Gold Bar is a low-grade, disseminated gold series of deposits with mineralization close to the surface at an average remaining head grade of 0.024 oz/t Au.

The phases were tabulated from the mineral resource block model and those tabulations were used as input to the development of the mine production schedule. Figure 13-1 illustrates the relative position of the three mining areas.

Waste rock will be stored in several waste rock facilities designed in close proximity to each pit to reduce haulage costs. Whenever possible, pit backfilling will be utilized if doing so proves to be economic during operations. Some waste mined late in the mine life will be placed in a designated storage facility to meet closure requirements.

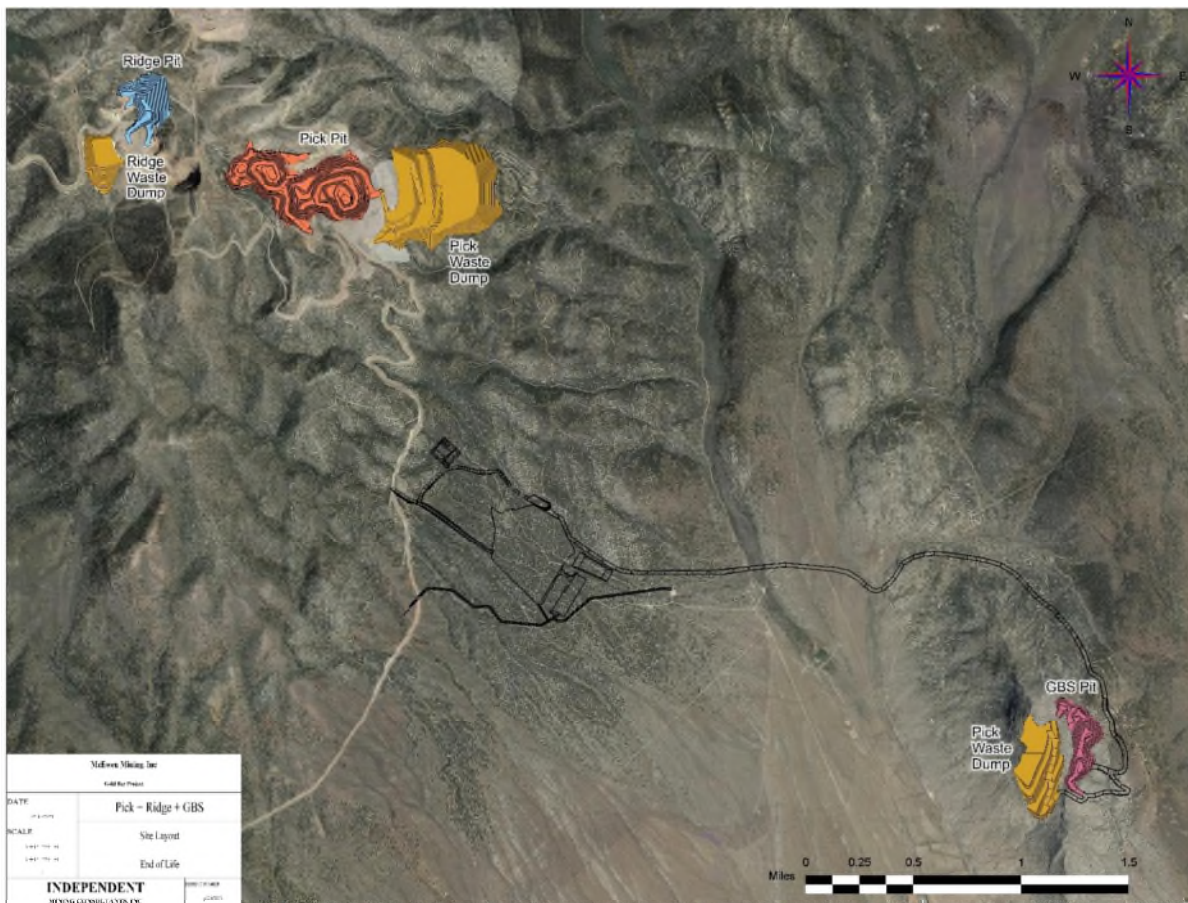


Figure 13-1: Gold Bar Relative Locations of Pit Designs (IMC, 2020)

**13.1 PRE-PRODUCTION AND MINE DEVELOPMENT**

Gold Bar has been in operation for over three years and is currently producing metal at site. Future mine development and access construction will be performed by the mining contractor. Access to many areas of the mine have already been established from previous mining activity. Extensive widening and recontouring of existing and new initial roads will be required to access the future mining areas of Ridge and Gold Bar South (GBS). Planned future access roads will be constructed utilizing tracked dozers, hammer blasthole rigs, and the proposed 100-ton ore mining fleet with a front-end loader.

A significant amount of access road development has already been completed by the previous and current operators. The existing roads will be utilized for primary haulage access to the Pick and Ridge pits. The Gold Bar South pit will require construction of a new road for haulage access.

The access road between the leach pad and Gold Bar South is long (approximately four miles), but it does not have the steep terrain challenges observed at Pick and Ridge. Ridge will require a substantial amount of stripping before ore can be reliably extracted from it. Gold Bar South outcrops near the surface, and stripping is expected to be minimal.

**13.2 PHASE DESIGN**

The Lerchs-Grossmann algorithm was used as a guide to the design of the phases. Multiple economic pits were developed using the costs, slope angles and recoveries outlined in Section 12. Metal prices were changed in order to establish a series of multiple nested pit geometries. The results of this work indicated the starting point, final pit and the extraction sequence that maximized the NPV throughout the mine life.

**13.2.1 Design Parameters**

The overall slope parameters are based on the geotechnical report by SRK, 2012 PFS (SRK, 2012a; SRK, 2012b, Piteau, 2020). These slopes are provided in Table 13-1 and were used in the mineral resource pit optimization. Low rock quality in geotechnical characterization drilling from Gold Ridge resulted in more conservative slope specifications for that pit compared to Gold Pick and the recently mined Cabin Creek. The geotechnical data for Gold Ridge is primarily based on a single drill hole. More geotechnical work should be performed prior to construction at Ridge to determine if a steeper slope angle can be achieved. The geotechnical data for Gold Bar South is based on five drill holes and no additional geotechnical work is expected within the current pit limits at GBS.

**Table 13-1: Overall Pit Slopes**

| <b>Area</b> | <b>Location</b> | <b>Max Interramp Slope Angle (degrees)</b> |
|-------------|-----------------|--|
| Pick        | Central         | 54   |
| GBS         | SE              | Varied                                     |
| Ridge       | West            | 42   |

Three mining areas were designed for the Gold Bar project with approximately 200-300 ft of operating width on each bench within a phase. The phases are designed to accommodate two-way haulage for a 100-ton haul fleet.

**Table 13-2: Road Design Parameters**

|                      |    |      |
|----------------------|----|------|
| <b>Road Width</b>    | 88 | (ft) |
| <b>Maximum Grade</b> | 10 | (%)  |

The design parameters for the phases were similar to those for the final pit as discussed in Section 12.

### **13.2.2 Gold Pick**

The majority of the ore to be mined at Gold Bar will be mined from Pick. Pick accounts for just over 80% of the ore feed at Gold Bar. Pick is planned as three phases: West, Central, and East mined from west to east. Pick will be mined with three 20-ft benches between each catch bench. The majority of Pick daylighting to the surface and much of the access is planned within the current design footprint.

The initial stripping at Pick has already been completed. The ore feed at Gold Bar is currently being mined from the western phase (Pick Phase 1) of Pick. Pick Phase 1 will continue to be mined throughout 2022 while Pick Phase 2 is brought into production.

The central phase (Pick Phase 2) will first be established with an extra wide ramp that connects into the current upper access and ties into the current lower access at Pick. Once the west (Pick Phase 1) phase is mined out, then the wide ramp will be mined out as the central (Pick Phase 2) phase is mined down. Pick Phase 2 will have independent access to the south from the east phase (Pick Phase 3).

The eastern phase (Pick Phase 3) has the largest stripping requirements of any of the planned phases at Gold Bar.

The Pick waste material will expand from the historic Pick Waste Facility located east of the Pick pit.

### **13.2.3 Gold Ridge**

Gold Ridge is located west of Pick and north of the historic Ridge pit mined by previous operators. The planned ore feed from Ridge currently accounts for less than 7% of the total planned ore feed. Ridge will be mined as one phase using two 20-ft benches between each catch bench. Nearly all of Ridge daylighting to the surface and the majority of the access is planned within the current design footprint.

The main access between Pick and Ridge will be widened to 88 feet wide. The upper benches will be accessed with one-way access roads but will be widened for two-way traffic as the material rate increases.

Ridge contains the lowest grade material that is planned for production at Gold Bar and the highest stripping ratio. Ridge has the highest cost per ounce of any of the planned phases. The exploration drilling density and geotechnical guidance within Gold Ridge is not as well defined as Pick and Gold Bar South. Future drilling campaigns at Ridge may improve grade estimation and stripping requirements.

The waste material will expand from the historic Ridge Waste Facility located southwest of the Ridge pit. The ore haulage from Ridge is approximately a five-mile haul that is mostly downhill. Approximately 80% of the ore from Ridge is planned to be crushed, and the remaining material will be placed as ROM.

### **13.2.4 Gold Bar South (GBS)**

Gold Bar South (GBS) is located a few miles southeast of the current processing facilities at Gold Bar. GBS accounts for approximately 12-13% of the total planned ore feed at Gold Bar. GBS will be mined as one phase using two 20ft

benches between each catch bench. Most of GBS daylight to the surface, and the majority of the access is planned within the current design footprint.

GBS has relatively higher grade and a lower stripping ratio than other planned phases. As a result, GBS contains the lowest cost per ounce material within the planned phases at Gold Bar.

Gold Bar South outcrops near the surface, and stripping is expected to be minimal. Waste to ore ratio at Gold Bar South is variable as it is mined; therefore, the ore delivery from GBS will be inconsistent from month-to-month. All of the material planned at GBS will not impact the crusher feed, because it is to be placed as ROM.

The waste from Gold Bar South will be placed southwest of the GBS pit. The GBS waste storage facility is located near the pit resulting in minimal waste haulage.

Forté evaluated the cost benefit of crushing at GBS, and it was determined that GBS would not benefit from crushing; therefore, all ore from GBS will be hauled directly to the leach pad as ROM. The ore haulage from GBS is approximately a five-mile haul that is mostly flat with an uphill component near the leach pad.

### **13.3 MINE PRODUCTION SCHEDULE**

The metal within the final pit designs was tabulated using a \$1,650/oz gold price. The planned ore feed to the crusher was tabulated at an internal cut-off grade. All areas of the mine are planned at 20ft bench heights. The mine plan has a remaining mine life of 6 years of operation.

The application of an elevated cut-off grade strategy did not improve the project NPV given the relatively short mine life. All pits are planned to be mined at the internal cut-off grade, which varies by area and processing type. The internal cut-off grades are provided in Table 13-2.

The multiple schedules were evaluated on a NPV basis at the project design prices that were used to establish the mineral reserve (Section 12). The best overall production schedule on an economic and practical basis was selected and costed for the economic analysis.

The mine production schedule was developed with the goal of loading the leach pad at the required production rates and maximizing the project return on investment. Multiple mine production schedules were developed that analyzed alternative cut-off grade strategies versus mine total material movement. Total material rates were tied to the size and number of loading units so that the final selected schedule would provide efficient use of the capital equipment employed.

The Gold Cut-off Grade for the mine plan and mineral reserve is:

$$\text{Gold Cut-off} = (\$1650 - \text{Sales Cost}) \times \text{Recovery}\% \times (1 - \text{Royalty}) + \text{Gold Contribution}$$

The total proven and probable mineral reserves related ore that is planned for processing in Table 12-3 is the mineral reserve as summarized in Section 12. Inferred mineralization is treated as waste within the mine plan and mineral reserve statement.

### **13.4 WASTE ROCK STORAGE DESIGN**

Waste rock from the Gold Bar pits can be separated into the following two waste rock management categories based on material type:

- Non-Designated Waste (59,110 ktons); and
- Designated Waste (1,658 ktons).

Three waste storage facilities are planned at each of the remaining mining areas of Pick, Ridge and Gold Bar South. The Pick waste will expand from the historic Pick waste dump east of the planned Pick phases between Pick and Cabin (already mined) areas. The Ridge waste will expand from the historic Ridge waste dump located southwest of the Ridge pit. GBS waste will be placed southwest of the planned pit at GBS.

The Pick waste facility is designed in stages from the top to bottom. The initial portion of the Pick waste facility is placed at an angle of repose (1.5 to 1). Concentric platforms (rings) will be filled in at the angle of repose and encompass the previously placed material every 100ft of vertical change in elevation. Once each waste platform is completed, then the lift above it can be recontoured to a reclamation angle (2.5 to 1) as the facility is constructed down the valley. The lower portions of the Pick waste facility will not meet reclamation angles unless all of the planned waste material is placed. Balancing the material placed with the remaining planned material as the facility is constructed will be key to maintain an overall final reclamation angle.

The Ridge waste facility is primarily constructed as a large fill ramp within the valley west of Ridge to maintain a reclamation angle.

The Gold Bar South waste facility will be constructed using conventional 100-ft lifts built from the bottom up and is designed to an overall reclamation angle of 2.5 to 1.

There is no provision for re-contouring of the waste dumps within the mine operating costs. Mine reclamation costs are not included within the mining costs because they were addressed separately by McEwen and their contractors to reduce haulage costs, and waste storage facilities were designed as close to each pit access point as possible. Whenever practical, waste rock was designed to backfill mined-out areas in former Atlas satellite pits. The amount of pit backfill is subject to change depending on economic and operational requirements.

#### **13.4.1 Non-Designated Waste Storage Design**

There are approximately 59.1 Mt of Non-Designated Waste, which comprises 97% of the remaining waste to be mined. The waste is defined as any material that falls below the economic CoG and is not Designated Waste as described below. It is composed primarily of oxidized and un-oxidized carbonate material consisting of limestone and dolomite, with localized clay alteration.

The waste rock storage facilities for the Project were designed to ensure operational stability and safety and to minimize work to achieve final reclamation at the end of the mine life. The majority of the waste rock generated during mining will be valley-fill, Non-Designated Waste.

There may be a future opportunity to backfill a portion of the west Pick pit when mining of the east Pick pit is active; however, this was not included in the current design as the mineral resource is still open to the north-west of the current Pick mining area.

#### **13.4.2 Designated Waste Storage Design**

There is approximately 1.7 Mt of designated waste at Gold Bar, which accounts for less than 3% of the remaining planned waste material at site. Nearly all of the designated waste is mined from the Pick phases (98.5%), with only ~31 ktons of designated waste mined from Ridge.

Designated Waste is defined as any un-oxidized material, regardless of gold grade, whose content of organic carbon and sulfides make it refractory or preg-robbing in heap leach processing. From an environmental perspective, this material has a low potential to generate acid but a high potential for metal leaching under expected neutral pH weathering conditions.

The designated waste is generally higher-grade material, but it cannot be extracted using the currently planned processing methods. The designated waste is detrimental to the recovery if placed on the leach pad. It is important that designated waste material be correctly identified and segregated from the ore shipped to the leach facility. This waste material is being stockpiled in the event that it might be extracted in the future using other methods of processing.

The designated waste will be stockpiled on the southern portion of the Pick waste facility and accessed separately from the already existing access to the Cabin area. As this waste is being placed, non-designated waste material will be stacked to the outside of the designated waste in order to buttress and encapsulate it. During reclamation, material from the Pick East Upper dump will be pushed out by dozer to cover the Designated Waste cell and graded to promote run-off.

### **13.5 MINE EQUIPMENT REQUIREMENTS**

The Gold Bar Project is planned to be mined by a contractor. Contractor equipment on hand is often variable. There is flexibility in the fleet size, and, thus, the actual mining fleet used for these phases will likely vary. Mine equipment is standard, off-the-shelf units.

Drilling will be completed with four rotary down-the-hole hammer drills with 45,000-lb pull down capacity and 6.75-in diameter blast holes. The blasted rock will be loaded into 100-ton haul trucks using three 16-cu yd front end loaders.

The auxiliary equipment consists of various sized track dozers, a wheel dozer, motor graders, water trucks, an auxiliary truck, and an excavator. The dozer sizes are consistent with Caterpillar D8-class, D9-class, and one D10-class dozers; these size dozers were selected to maintain the dumps and for cleanup in the pit. Two Caterpillar 18-class motor graders will be used to maintain the roads and remove snow. Two, 8,000-gal articulating water trucks were sized to adequately maintain dust control on the haul roads.

Three, front-end wheel loaders were selected to match production requirements based on the financial analysis of the mine schedule. The mobility of the front-end loaders is a benefit to mine operations. The majority of the time only two loaders will be in production, but a third loader will provide greater flexibility and increased mechanical availability.

Truck fleet requirements were developed from haul time simulation over profiles measured for each material type, by phase, for each period of the mine plan. The detailed haulage profiles and production schedule information, cycle times and then equipment requirements were determined by IMC.

Table 13-3 summarizes the major mine equipment units that will be on site throughout the mine life. Table 13-4 summarizes the material characteristics used for calculating the fleet requirements. Table 13-5 summarizes the utilization and availability of the mining equipment.



**Table 13-3: Fleet Requirements (IMC, 2020)**

| Major Mine Equipment<br>Equipment Type                          | Max<br>Units |
|---|--------------|
| CAT MD6200 Waste Rotary Drill (6.75 in bit / 35000 lb pulldown) | 4            |
| CAT 992K Front End Loader (16 CuYd bucket / 1050 HP)            | 3            |
| CAT 777G Haul Truck (83.8 CuYd bed / 100 t)                     | 12           |
| CAT D8-D9-D10 Track Dozers (14-15-17 ft blade / 312-436-600 HP) | 3            |
| CAT 834K Wheel Dozer (16.7 ft blade / 562 HP)                   | 1            |
| CAT 18M Motor Graders (18 ft blade / 304 HP)                    | 2            |
| CAT 773G WTR Water Truck (8000 gal tank / 45 t)                 | 2            |
| CAT 938 IT Aux Loader (4 CuYd bucket / 188 HP)                  | 1            |
| CAT 745 Aux Truck (24.2 CuYd bed / 45 t)                        | 1            |
| CAT 349 Excavator (4 CuYd bucket / 396 HP)                      | 1            |

\* The haulage fleet can be reduced to 8 trucks if the stripping of Ridge is advanced into year 2

**Table 13-4: Material Characteristics (IMC, 2020)**

| PARAMETER                  | ORE    | WASTE  | FILL   |
|----------------------------|--------|--------|--------|
| Dry Bank Density (CuFt/t)  | 13.232 | 12.821 | 16.500 |
| Material Handling Swell    | 40.0%  | 40.0%  | 40.0%  |
| Moisture Content           | 2.5%   | 2.5%   | 2.5%   |
| Dry Loose Density (CuFt/t) | 18.52  | 17.95  | 23.10  |
| Wet Loose density (CuFt/t) | 18.99  | 18.40  | 23.68  |

**Table 13-5: Utilization and Availability of Mining Equipment (IMC, 2020)**

| Equipment Type  | Mechanical<br>Availability | Utilization of<br>Availability | Maximum<br>Utilization |
|---|----------------------------|--------------------------------|------------------------|
| CAT MD6200 Waste Rotary Drill (6.75 in bit / 45000 lb pulldown) | 0.80                       | 0.85                           | 0.680                  |
| CAT 992K Front End Loader (16 CuYd bucket / 1050 HP)            | 0.95                       | 0.90                           | 0.855                  |
| CAT 777G Haul Truck (83.8 CuYd bed / 100 t)                     | 0.95                       | 0.90                           | 0.855                  |
| CAT D8-D9-D10 Track Dozers (14-15-17 ft blade / 312-436-600 HP) | 0.85                       | 0.70                           | 0.595                  |
| CAT 834K Wheel Dozer (16.7 ft blade / 562 HP)                   | 0.85                       | 0.60                           | 0.510                  |
| CAT 18M Motor Graders (18 ft blade / 304 HP)                    | 0.85                       | 0.60                           | 0.510                  |
| CAT 773G WTR Water Truck (8000 gal tank / 45 t)                 | 0.85                       | 0.60                           | 0.510                  |
| CAT 938 IT Aux Loader (4 CuYd bucket / 188 HP)                  | 0.85                       | 0.60                           | 0.510                  |
| CAT 745 Aux Truck (24.2 CuYd bed / 45 t)                        | 0.85                       | 0.60                           | 0.510                  |
| CAT 349 Excavator (4 CuYd bucket / 396 HP)                      | 0.85                       | 0.60                           | 0.510                  |

### 13.6 MANPOWER REQUIREMENTS

During production, mining operations will require crews operating on ten-hour, rotating shifts six days per week. Because of the distance from the town of Eureka, the crews will be transported to the site in company-supplied vans.

Mining crew manpower is to be provided by the mining contractor.

**Table 13-6: Fleet Requirements (IMC, 2022)**

| Scheduled Mine Days and Shifts Per Year |                  |            |                  |                 |                  |
|---|------------------|------------|------------------|-----------------|------------------|
| Mining Year                             | Scheduled Shifts |            |                  | Lost (1) Shifts | Available Shifts |
|   | Scheduled Days   | Shifts/Day | Scheduled Shifts |                 |                  |
| QTR1 - 2022                             | 72               | 2          | 144              | 6               | 138              |
| QTR2 - 2022                             | 91               | 2          | 182              | 4               | 178              |
| QTR3 - 2022                             | 92               | 2          | 184              | 4               | 167              |
| QTR4 - 2022                             | 92               | 2          | 184              | 6               | 178              |
| QTR1 - 2023                             | 90               | 2          | 180              | 4               | 176              |
| QTR2 - 2023                             | 91               | 2          | 182              | 4               | 178              |
| QTR3 - 2023                             | 92               | 2          | 184              | 6               | 178              |
| QTR4 - 2023                             | 92               | 2          | 184              | 6               | 178              |
| QTR1 - 2024                             | 90               | 2          | 180              | 2               | 176              |
| QTR2 - 2024                             | 91               | 2          | 182              | 2               | 178              |
| QTR3 - 2024                             | 92               | 2          | 184              | 3               | 178              |
| QTR4 - 2024                             | 92               | 2          | 184              | 3               | 178              |
| QTR1 - 2025                             | 91               | 2          | 182              | 2               | 176              |
| QTR2 - 2025                             | 91               | 2          | 182              | 2               | 178              |
| QTR3 - 2025                             | 92               | 2          | 184              | 3               | 178              |
| QTR4 - 2025                             | 92               | 2          | 184              | 3               | 178              |
| QTR1 - 2026                             | 90               | 2          | 180              | 2               | 176              |
| QTR2 - 2026                             | 91               | 2          | 182              | 2               | 178              |
| QTR3 - 2026                             | 92               | 2          | 184              | 3               | 178              |
| QTR4 - 2026                             | 92               | 2          | 184              | 3               | 178              |
| QTR1 - 2027                             | 90               | 2          | 180              | 2               | 176              |
| QTR2 - 2027                             | 91               | 2          | 184              | 2               | 178              |
| QTR3 - 2027                             | 92               | 2          | 184              | 3               | 178              |
| QTR4 - 2027                             | 92               | 2          | 184              | 3               | 178              |
| Total                                   | 2,173            |            | 4,348            | 80              | 4,211            |

(1) Lost shifts include holidays & 6-day work weeks

**Table 13-7: Operating Time Per Shift (IMC, 2022)**

| <b>Summary of Operating Time Per Shift</b>                   |       |
|--|-------|
| Scheduled Time Per Shift (min)                               | 720   |
| Less Scheduled Nonproductive Times                           |       |
| Travel Time/Shift Change/Blasting (min)                      | 10    |
| Equipment Inspection (min)                                   | 10    |
| Lunch/Breaks   | 30    |
| Fueling, Lube, & Service (min)                               | 10    |
| Net Scheduled Productive Time (Metered Operating Time) (min) | 660   |
| Job Efficiency (50 Minutes Productive Time Per Metered Hour) | 83.3% |
| Net Productive Operating Time Per Shift (min)                | 550   |

13.7 PERIOD DRAWINGS

The following figure present the end of mine life drawing (Figure 13-2).



Figure 13-2: Mining Progression – End of Year 2027 (Final Pit), (IMC, 2022)

## **14 PROCESSING AND RECOVERY METHODS**

### **14.1 PROCESS FLOW SHEET**

The Gold Bar gold deposit will be mined as three open pits: Ridge, Pick, Gold Bar South. Ore from all three pits will be processed through conventional heap leaching and adsorption, desorption, regeneration (ADR) technology for precious metal recovery. Placed ore is a combination of crushed, agglomerated, and ROM ore. The processing facilities can accommodate a leachable reserve of approximately 15.6 Mt of ore at a gold grade of 0.025 oz/t and a target process rate of 7,900 tpd. The new heap leach pad has been located and designed with expandability for an ore reserve increase.

The process flow sheet is shown in Figure 14-1. Ore is delivered from the mine and placed in a stockpile adjacent to the crushing plant or routed directly to the leach pad in the case of ROM. The crushing circuit consists of a single stage crusher discharging to an overland conveyor that transports the crushed ore to the leach pad. An optional agglomeration circuit is included for operation when needed. Crushed ore will be stacked onto the heap using a radial stacker. A dilute cyanide solution is used to extract the precious metal from placed ore. The gold will then be recovered from the pregnant solution in the carbon plant by adsorbing the dissolved gold onto activated carbon followed by desorption, electrowinning, retorting and smelting to recover the gold as a final doré product.

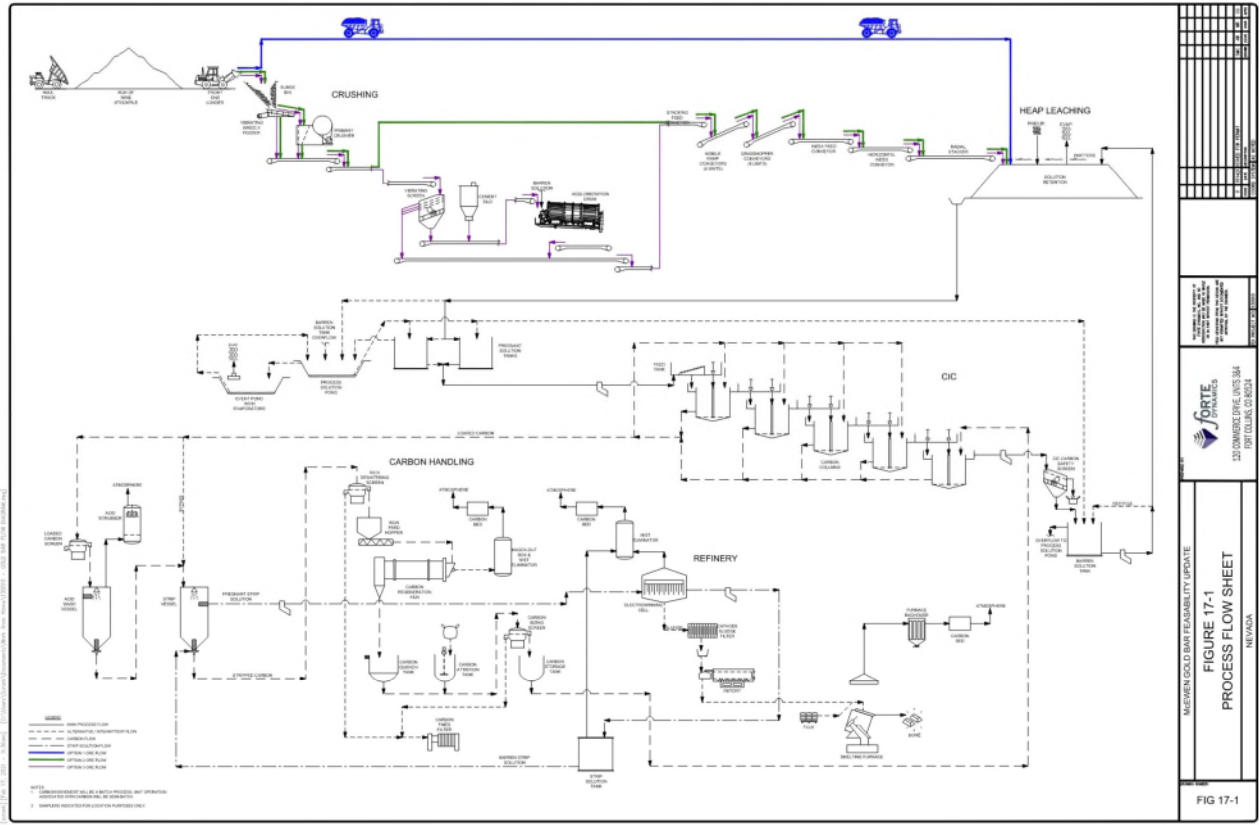


Figure 14-1: Process Flow Sheet (Forte, 2020)

|     |      |         |                             |
|-----|------|---------|-----------------------------|
| NO. | REV. | DATE    | DESCRIPTION                 |
| 1   | 1    | 03/2020 | ISSUED FOR REVIEW           |
| 2   | 2    | 04/2020 | REVISED TO REFLECT COMMENTS |
| 3   | 3    | 05/2020 | REVISED TO REFLECT COMMENTS |
| 4   | 4    | 06/2020 | REVISED TO REFLECT COMMENTS |
| 5   | 5    | 07/2020 | REVISED TO REFLECT COMMENTS |
| 6   | 6    | 08/2020 | REVISED TO REFLECT COMMENTS |
| 7   | 7    | 09/2020 | REVISED TO REFLECT COMMENTS |
| 8   | 8    | 10/2020 | REVISED TO REFLECT COMMENTS |
| 9   | 9    | 11/2020 | REVISED TO REFLECT COMMENTS |
| 10  | 10   | 12/2020 | REVISED TO REFLECT COMMENTS |
| 11  | 11   | 01/2021 | REVISED TO REFLECT COMMENTS |
| 12  | 12   | 02/2021 | REVISED TO REFLECT COMMENTS |
| 13  | 13   | 03/2021 | REVISED TO REFLECT COMMENTS |
| 14  | 14   | 04/2021 | REVISED TO REFLECT COMMENTS |
| 15  | 15   | 05/2021 | REVISED TO REFLECT COMMENTS |
| 16  | 16   | 06/2021 | REVISED TO REFLECT COMMENTS |
| 17  | 17   | 07/2021 | REVISED TO REFLECT COMMENTS |
| 18  | 18   | 08/2021 | REVISED TO REFLECT COMMENTS |
| 19  | 19   | 09/2021 | REVISED TO REFLECT COMMENTS |
| 20  | 20   | 10/2021 | REVISED TO REFLECT COMMENTS |
| 21  | 21   | 11/2021 | REVISED TO REFLECT COMMENTS |
| 22  | 22   | 12/2021 | REVISED TO REFLECT COMMENTS |
| 23  | 23   | 01/2022 | REVISED TO REFLECT COMMENTS |
| 24  | 24   | 02/2022 | REVISED TO REFLECT COMMENTS |
| 25  | 25   | 03/2022 | REVISED TO REFLECT COMMENTS |
| 26  | 26   | 04/2022 | REVISED TO REFLECT COMMENTS |
| 27  | 27   | 05/2022 | REVISED TO REFLECT COMMENTS |
| 28  | 28   | 06/2022 | REVISED TO REFLECT COMMENTS |
| 29  | 29   | 07/2022 | REVISED TO REFLECT COMMENTS |
| 30  | 30   | 08/2022 | REVISED TO REFLECT COMMENTS |
| 31  | 31   | 09/2022 | REVISED TO REFLECT COMMENTS |
| 32  | 32   | 10/2022 | REVISED TO REFLECT COMMENTS |
| 33  | 33   | 11/2022 | REVISED TO REFLECT COMMENTS |
| 34  | 34   | 12/2022 | REVISED TO REFLECT COMMENTS |
| 35  | 35   | 01/2023 | REVISED TO REFLECT COMMENTS |
| 36  | 36   | 02/2023 | REVISED TO REFLECT COMMENTS |
| 37  | 37   | 03/2023 | REVISED TO REFLECT COMMENTS |
| 38  | 38   | 04/2023 | REVISED TO REFLECT COMMENTS |
| 39  | 39   | 05/2023 | REVISED TO REFLECT COMMENTS |
| 40  | 40   | 06/2023 | REVISED TO REFLECT COMMENTS |
| 41  | 41   | 07/2023 | REVISED TO REFLECT COMMENTS |
| 42  | 42   | 08/2023 | REVISED TO REFLECT COMMENTS |
| 43  | 43   | 09/2023 | REVISED TO REFLECT COMMENTS |
| 44  | 44   | 10/2023 | REVISED TO REFLECT COMMENTS |
| 45  | 45   | 11/2023 | REVISED TO REFLECT COMMENTS |
| 46  | 46   | 12/2023 | REVISED TO REFLECT COMMENTS |
| 47  | 47   | 01/2024 | REVISED TO REFLECT COMMENTS |
| 48  | 48   | 02/2024 | REVISED TO REFLECT COMMENTS |
| 49  | 49   | 03/2024 | REVISED TO REFLECT COMMENTS |
| 50  | 50   | 04/2024 | REVISED TO REFLECT COMMENTS |
| 51  | 51   | 05/2024 | REVISED TO REFLECT COMMENTS |
| 52  | 52   | 06/2024 | REVISED TO REFLECT COMMENTS |
| 53  | 53   | 07/2024 | REVISED TO REFLECT COMMENTS |
| 54  | 54   | 08/2024 | REVISED TO REFLECT COMMENTS |
| 55  | 55   | 09/2024 | REVISED TO REFLECT COMMENTS |
| 56  | 56   | 10/2024 | REVISED TO REFLECT COMMENTS |
| 57  | 57   | 11/2024 | REVISED TO REFLECT COMMENTS |
| 58  | 58   | 12/2024 | REVISED TO REFLECT COMMENTS |
| 59  | 59   | 01/2025 | REVISED TO REFLECT COMMENTS |
| 60  | 60   | 02/2025 | REVISED TO REFLECT COMMENTS |
| 61  | 61   | 03/2025 | REVISED TO REFLECT COMMENTS |
| 62  | 62   | 04/2025 | REVISED TO REFLECT COMMENTS |
| 63  | 63   | 05/2025 | REVISED TO REFLECT COMMENTS |
| 64  | 64   | 06/2025 | REVISED TO REFLECT COMMENTS |
| 65  | 65   | 07/2025 | REVISED TO REFLECT COMMENTS |
| 66  | 66   | 08/2025 | REVISED TO REFLECT COMMENTS |
| 67  | 67   | 09/2025 | REVISED TO REFLECT COMMENTS |
| 68  | 68   | 10/2025 | REVISED TO REFLECT COMMENTS |
| 69  | 69   | 11/2025 | REVISED TO REFLECT COMMENTS |
| 70  | 70   | 12/2025 | REVISED TO REFLECT COMMENTS |
| 71  | 71   | 01/2026 | REVISED TO REFLECT COMMENTS |
| 72  | 72   | 02/2026 | REVISED TO REFLECT COMMENTS |
| 73  | 73   | 03/2026 | REVISED TO REFLECT COMMENTS |
| 74  | 74   | 04/2026 | REVISED TO REFLECT COMMENTS |
| 75  | 75   | 05/2026 | REVISED TO REFLECT COMMENTS |
| 76  | 76   | 06/2026 | REVISED TO REFLECT COMMENTS |
| 77  | 77   | 07/2026 | REVISED TO REFLECT COMMENTS |
| 78  | 78   | 08/2026 | REVISED TO REFLECT COMMENTS |
| 79  | 79   | 09/2026 | REVISED TO REFLECT COMMENTS |
| 80  | 80   | 10/2026 | REVISED TO REFLECT COMMENTS |
| 81  | 81   | 11/2026 | REVISED TO REFLECT COMMENTS |
| 82  | 82   | 12/2026 | REVISED TO REFLECT COMMENTS |
| 83  | 83   | 01/2027 | REVISED TO REFLECT COMMENTS |
| 84  | 84   | 02/2027 | REVISED TO REFLECT COMMENTS |
| 85  | 85   | 03/2027 | REVISED TO REFLECT COMMENTS |
| 86  | 86   | 04/2027 | REVISED TO REFLECT COMMENTS |
| 87  | 87   | 05/2027 | REVISED TO REFLECT COMMENTS |
| 88  | 88   | 06/2027 | REVISED TO REFLECT COMMENTS |
| 89  | 89   | 07/2027 | REVISED TO REFLECT COMMENTS |
| 90  | 90   | 08/2027 | REVISED TO REFLECT COMMENTS |
| 91  | 91   | 09/2027 | REVISED TO REFLECT COMMENTS |
| 92  | 92   | 10/2027 | REVISED TO REFLECT COMMENTS |
| 93  | 93   | 11/2027 | REVISED TO REFLECT COMMENTS |
| 94  | 94   | 12/2027 | REVISED TO REFLECT COMMENTS |
| 95  | 95   | 01/2028 | REVISED TO REFLECT COMMENTS |
| 96  | 96   | 02/2028 | REVISED TO REFLECT COMMENTS |
| 97  | 97   | 03/2028 | REVISED TO REFLECT COMMENTS |
| 98  | 98   | 04/2028 | REVISED TO REFLECT COMMENTS |
| 99  | 99   | 05/2028 | REVISED TO REFLECT COMMENTS |
| 100 | 100  | 06/2028 | REVISED TO REFLECT COMMENTS |

MEWEN GOLD BAR FEASIBILITY UPDATE  
 FIGURE 17-1  
 PROCESS FLOW SHEET  
 NEVADA

**14.2 CRUSHING, AGGLOMERATING AND STACKING**

The crushing and stacking circuits are designed for 480 dry short tons per hour (stph), with operations scheduled for 24 hours per day, seven days per week, 350 days per year. At an expected 70% operating availability, this will result in placing an average of 8,057 stpd onto the heap leach pad, equivalent to 2,820,000 tons per year.

Ore will be trucked from the mine to either a stockpile close to the primary crusher and subsequently reclaimed with a front-end loader (FEL) or hauled directly to the heap leach pad depending on the grade. The FEL will dump ore into a surge bin. A vibrating grizzly feeder will draw ore from the surge bin, with the feeder oversize reporting to a jaw crusher. The grizzly feeder undersize material will bypass the crusher and will combine with the crusher product on the primary discharge belt conveyor.

The crushed ore will be transferred to the leach pad via an overland conveyor that discharges on to a series of several mobile ramp conveyors and mobile grasshopper-type conveyors. Units of mobile conveyors and grasshopper-type conveyors will be added or removed as required, dependent upon the stacking location on the pad. The final conveyor will be a radial-type mobile stacker that will place agglomerated ore in lifts, up to 25 feet in height. As multiple lifts are placed, the edges of the heap will be concurrently reclaimed to a 3:1 slope. This will reduce closure costs and facilitate safer and easier leaching of the slopes.

Agglomeration is anticipated for only select material for the ores at Gold Bar North or South. If needed, the agglomeration drum and cement addition will remain in the circuit following the crushing and prior to the conveying system. The grizzly undersize and the primary crushed ore will be conveyed to a vibrating, inclined screen. Screen oversize (+3 inch) will bypass the agglomeration drum and report to the screening discharge belt conveyor. The undersize fraction from the screen will be conveyed to the agglomeration drum for the binding process. Cement and barren solution will be added on the screen undersize conveyor ahead of the drum. Agglomerated ore will combine with the screen oversize on the screening discharge belt conveyor. The agglomeration drum and all downstream material handling equipment are physically located within the containment of the heap leach pad liner system.

An evaluation of the test work suggests that the processing should be a mix of crushed and ROM ore placed on the leach pad. Further test work is underway to evaluate the optimum size of ore to be placed on the leach pad and the recoveries of those ores. This test work will allow the calculation of the most economic mix of crushed and ROM ores to be processed.

Table 14-1 provides the key crushing agglomerating and stacking process design parameters.

**Table 14-1: Key Crushing, Agglomeration and Stacking Process Design Parameters (Forte, 2020)**

| <b>Crushing, Agglomerating and Stacking</b>           | <b>Unit</b>        | <b>Design</b> |
|---|--------------------|---------------|
| Crushing and Stacking Process Rate                    | tpd                | 8,057         |
| Crushing and Stacking Throughput Rate                 | tph                | 480           |
| Screen Aperture – Bottom Deck                         | inch               | 3             |
| Ore Bulk Density                                      | lb/ft <sup>3</sup> | 94            |
| Ore Crushing Work Index                               | kWh/t              | 14.6          |
| Agglomeration Cement (If required)                    | lbs/ton            | 14            |
| Stacked Ore Height                                    | ft                 | 25            |
| Crushing & Agglomeration Plant Operating Availability | %                  | 70            |

**14.3 HEAP LEACH PAD DESIGN**

The following is a summary of the proposed heap leach pad design. Key heap leach process design parameters are provided in Table 14-2.

**Table 14-2: Key Heap Leach Process Design Parameters**

| Heap Leaching                       | Unit                | Design                           |
|-------------------------------------|---------------------|----------------------------------|
| Ore Lift Height                     | ft                  | 25                               |
| Solution Application Rate           | gpm/ft <sup>2</sup> | 0.004/0.002                      |
| Leach Cycle                         | days                | 30 preparation and 90 irrigation |
| Tons Under Leach                    | ktons               | 966                              |
| Area Under Leach                    | ft <sup>2</sup>     | 600,000                          |
| Cyanide Concentration               | lb/t soln.          | 1.0                              |
| Leach Solution pH                   | pH                  | 10.5 to 11.0                     |
| Pregnant Solution Flow Rate         | gpm                 | 1,798                            |
| Barren Solution Flow Rate           | gpm                 | 1956                             |
| Average Pregnant Solution Grade     | Oz/t soln. Au+Ag    | 0.030                            |
| Process Pond Capacity               | mgal                | 7.16                             |
| Event Pond Capacity                 | mgal                | 6.12                             |
| Metal Recovery Plant Operating Time | %                   | 98                               |

Source: SRK, 2015; Newfields, 2018

The heap leach pad is designed to be constructed in two phases (Phases 1A and 1B) with 4 cells each, for a total of 8 cells. The leach pad and process facilities extend from an elevation of 6,750 ft amsl at the toe of the process ponds to an elevation of 6,980 ft amsl at the northwestern edge of the leach pad perimeter road. The slope of the lined base receiving ore will range from 7 to 8% on the western half and 2 to 4% on the eastern half. In total, the leach pad will have a total lined area of 4.18 million ft<sup>2</sup>, or approximately 96 acres. The final reclaimed surface of the leach pad will be graded to an 8% top slope with 3H:1V (horizontal to vertical) side slopes and will be covered with 2 ft of growth media. The leach pad design provides a total ore capacity of approximately 13.8 million yd<sup>3</sup>, or 17.5 Mt using an average dry density of 94 lb/ft<sup>3</sup> (1.27 t/yd<sup>3</sup>) for stacked ore.

Prior to development, the footprint of each facility was cleared and grubbed of existing vegetation and topsoil. Cut-to-fill regrading was utilized where possible to minimize earthworks requirements. Excess soil removed from the base of each phase will be stockpiled for later use as growth media to provide for the estimated 332,000 yd<sup>3</sup> of cover to be placed over the finished leach pad at the end of the Project for reclamation.

The leach pad liner system is a compacted 12-inch-thick low-permeability subgrade layer overlain by a single geosynthetic liner. The primary geosynthetic liner will be a double-side textured 80-mil high-density polyethylene (HDPE) geomembrane liner. The subgrade layer consists of 12 inches of either imported low-permeability soil or an admixture of bentonite and native soil to achieve a hydraulic conductivity of 1x10<sup>-6</sup> centimeters per second (cm/sec) or less.

The solution channel, Process Solution Pond, and Event Pond were both constructed with a double synthetic liner system consisting of an HDPE geonet between an 80-mil HDPE primary liner and a 60-mil HDPE secondary liner. Each pond liner system is equipped with a leak collection and recovery system (LCRS). The pregnant solution collected



at the base of the heap via the overliner solution recovery system is routed to pregnant solution tanks at the Process Solution Pond via a solid-wall HDPE conveyance pipe installed in the lined solution channel.

The Phase 1A leach pad has been completed along with the ponds, and solution conveyance systems and is currently in operation. The leach pad will require two additional phases of expansion. The initial expansion, Phase 1B will complete the Phase 1 pad. A final expansion is planned, Phase 2, to accommodate the total amount of ore in reserves. Both expansions are planned to be constructed similarly to the existing design.

A seismic hazard analysis was performed for the heap leach pad design using the Probabilistic Seismic Hazard Analysis (PSHA) method. Stability analyses were performed on critical slope surfaces using the computer program SLIDE (Version 7). For all analyses, the factors of safety (FOS) under static and pseudostatic conditions are higher than the required minimum FOS of 1.3 and 1.05 (NDEP, 1994). The proposed heap leach pad configuration will be stable under both static and pseudostatic conditions for both the initial lift and final ore grading configurations.

During operations, storm water runoff from the heap are captured by the solution collection system, channeled to the process ponds, and incorporated in the process circuit. The designs of the Process Solution and Event Ponds provide for storage of a 12-hour operating volume, the volume of the 25-year and 100-year, 24-hour storm events falling on the pad and ponds, and dead storage to allow for pump operation. Following closure, storm water run-off from the covered and reclaimed heap surface will be collected by a trapezoidal channel constructed on the interior side of the perimeter access road, which will route flows to the northeast and southeast corners of the heap and discharge them into adjacent natural drainages.

#### **14.4 PROCESSING PLANT DESIGN AND OPERATIONS**

##### **14.4.1 Metal Recovery Plant Design and Operations**

A carbon ADR circuit is used at the Gold Bar Mine to recover gold and silver from the pregnant solution. The ADR plant recovers and sends concentrated gold solution to the refinery where the final marketable doré bars are produced. Pregnant solution from the heap leach pad flows by gravity to the pregnant solution tanks. From the pregnant solution tanks, the solution is pumped to the ADR plant, where soluble gold and silver adsorb onto activated carbon. Adsorption of the gold onto activated granular coconut shell carbon is conducted in a five-stage counter current carbon-in-column (CIC) circuit. Carbon is advanced from column to column counter current to the pregnant solution flow so that the highest-grade carbon contacts the highest grade pregnant solution and the most active fresh carbon contacts the lowest grade solution.

Loaded carbon from the first adsorption column is pumped to an acid wash vessel and acid washed by circulating dilute nitric acid upwards through the bed of carbon to remove scale build-up (mainly calcium) to maintain the carbon's ability to recover gold and expose the surface to improve gold elution efficiency. Residual acid in the acid wash vessel is neutralized with caustic before the loaded carbon is transferred to the strip (elution) vessel. Hot caustic cyanide solution is pumped through the strip vessel to remove the gold and silver from the loaded carbon. Elution is conducted at 100 psi and 300°F for up to ten hours. Sodium hydroxide is added to the stripping solution to aid stripping and provide electrolyte for the subsequent electrowinning stage.

Stripped carbon is transferred to the regeneration circuit where carbon will be thermally regenerated in a horizontal rotary kiln or the carbon may be sent directly to the sizing circuit and returned to the carbon columns. Stripped carbon is washed with water then screened to remove fines prior to being fed to the regeneration kiln. There it is heated to approximately 1,200 to 1,400°F in a moist, oxygen-free atmosphere to reactivate its surfaces before it is reused in the carbon columns.

Recovery of precious metals from the rich pregnant strip solution is conducted in a single electrowinning (EW) cell. Electrowinning removes the precious metals from the pregnant solution by passing direct current through an

electrowinning cell. The rich strip solution is transferred to the electrowinning cells. The precious metal ions transfer from the solution to the stainless-steel wool cathode and deposit onto the steel wool as a weakly bonded sludge. The barren EW solution is then returned to the stripping circuit, completing the elution cycle. The barren strip solution from the electrowinning cell is collected in the EW barren return tank and pumped to the strip solution tank for reuse in the strip circuit. The sludge in the electrowinning cell is washed off the cathodes in batches and recovered as a damp cake in the cathode sludge filter press.

Filter cake is retorted to remove and recover mercury prior to smelting the dried sludge to produce doré bars. Filter cake is collected in pans. The pans are placed in a mercury retort system for several hours. The retort then heats the filtered cake to approximately 1,100°F to vaporize mercury. The retort temperature is ramped up gradually to enable the sludge to dry completely before mercury is vaporized and to allow time for the mercury to diffuse to the solid surfaces. Retort vapor is withdrawn from the retort by a vacuum pump, which pulls the vapor through a condenser where the mercury condenses and flows into a mercury collection compartment. Mercury is removed as required.

Following a cooldown period, the dried (retorted) cake is mixed with fluxes and charged to an electric induction furnace and heated to approximately 2,250°F. When the furnace charge is fully molten, it separates into two distinct layers: the slag (on the top) and metal (on the bottom). The slag layer, containing fused fluxes and impurities, is poured first into conical pots. Once slag has been removed, the melted gold and silver (metal layer) is poured into molds to form doré bars.

Bars are cooled, cleaned, weighed, and stamped with an identification number and weight. Doré bars are the final product of the plant which will be shipped to the market at 90-95% Au/Ag purity.

Table 14-3 provides the feasibility design parameters for the ADR Plant.

**Table 14-3: Key ADR Process Design Parameters (Forte, 2020)**

| ADR Plant Operation           | Unit                | Design |
|-------------------------------|---------------------|--------|
| <i>CIC Adsorption Circuit</i> |                     |        |
| Column Carbon Capacity        | tons/column         | 3.0    |
| Carbon Size                   | Mesh                | 6 x 12 |
| Column Flow Rate              | gpm                 | 1,798  |
| Pregnant Solution Grade       | oz/t soln. Au+Ag    | 0.030  |
| Carbon Loading                | oz Au+Ag/ton carbon | 129    |
| Barren Grade                  | oz/t soln. Au+Ag    | 6.5    |
| Adsorption Efficiency         | %                   | 99     |
| Operating Time                | %                   | 98     |
| <i>Desorption Circuit</i>     |                     |        |
| Column Carbon Capacity        | tons/strip          | 3.0    |
| Flow Rate                     | gpm                 | 50     |
| Elution Temperature           | deg. F              | 300    |
| Elution Pressure              | psig                | 100    |
| Elution Time                  | hrs                 | 10     |
| NaOH Concentration            | %                   | 2.0    |
| Efficiency                    | %                   | 95     |

| <b>ADR Plant Operation</b> | <b>Unit</b>        | <b>Design</b> |
|----------------------------|--------------------|---------------|
| <i>Acid Wash</i>           |                    |               |
| Column Carbon Capacity     | tons               | 3.0           |
| Nitric Acid Concentration  | %                  | 3.0           |
| <i>Carbon Reactivation</i> |                    |               |
| Throughput Rate            | lb/hr              | 311           |
| Temperature                | deg. F             | 1,200         |
| <i>Mercury Retort</i>      |                    |               |
| Temperature                | deg. F             | 1,100         |
| <i>Electrowinning</i>      |                    |               |
| Flow Rate                  | gpm                | 50            |
| Rich Electrolyte           | oz Au+Ag/ton soln. | 2.0           |
| Lean Electrolyte           | oz Au+Ag/ton soln. | 0.6           |
| Rectifier                  | kW                 | 9             |
| Current Density            | A/m <sup>2</sup>   | 200           |
| Efficiency                 | %                  | 90-97         |
| <i>Smelting</i>            |                    |               |
| Temperature                | deg. F             | 2,200         |
| Fluxes                     | lb/oz Au + Ag      | 0.156         |
| Pour Per Month             | each               | 8             |
| Ounces Per Pour            | oz Au+Ag           | 768           |

## **14.5 CONSUMABLE REQUIREMENTS**

### **14.5.1 Power**

Three natural gas generators are used to supply power to the crushing, screening, processing loads and supporting infrastructure.

### **14.5.2 Water Supply**

The peak make-up water requirement for the Project is 450 gpm. The water source for the Project will be from production water wells located approximately two miles southeast from site.

### **14.5.3 Major Reagents**

Major reagents and usage for the heap leach operation are provided in Table 14-4. Reagent consumption was determined during metallurgical test work performed by KCA in 2011 and 2015 and confirmed during operations.

**Table 14-4: Major Reagent Consumption (Forte, 2020)**

| Reagent               | Use        |
|-----------------------|------------|
| Agglomeration Cement* | 14.0 lb/t  |
| Sodium Cyanide        | 0.30 lb/t  |
| Caustic Soda          | 0.05 lb/t  |
| Antiscalant           | 0.03 lb/t  |
| Nitric Acid           | 0.09 lb/t  |
| Carbon                | 0.013 lb/t |
| Refinery Fluxes       | 0.024 lb/t |

*\*Agglomeration Cement addition, if needed, is based on 20 lb/t of material to be agglomerated (fines). The fines fraction of the ore is 70%; hence, the equivalent cement consumption rate per ton of ore is 14 lb/t.*

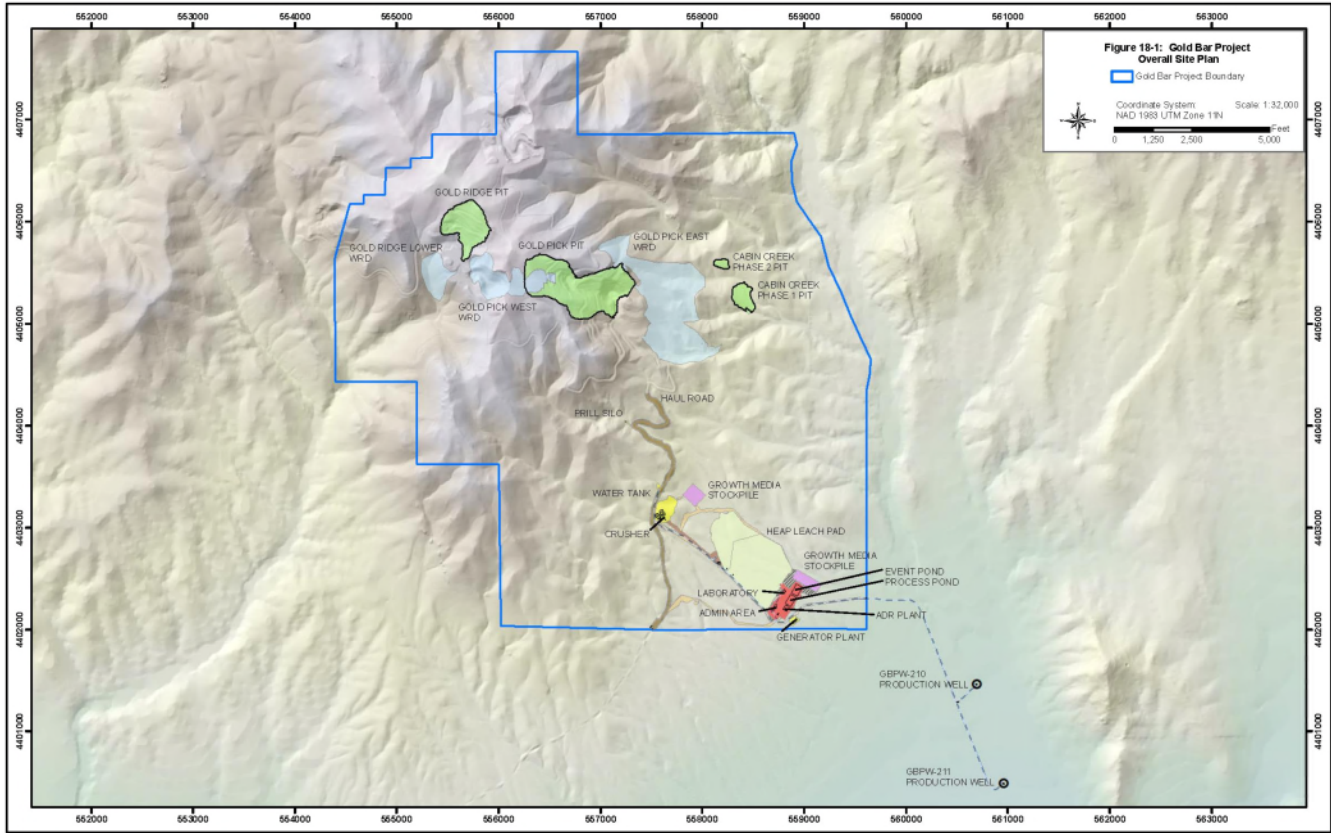
## **15 INFRASTRUCTURE**

### **15.1 SITE ACCESS**

Heavy vehicle traffic accesses the Project site via U.S. Highway 50 by traveling north on the existing Three Bars Road (Eureka County designation M-107) for approximately 16 miles, and then east for 1.5 miles on the existing Gold Bar Road (Eureka County designation G-215) to the former Atlas Mill area. From the former mill area, access is gained to the east on the existing Atlas Haul Road (Eureka County designation G-215) for approximately seven miles to the mine facilities.

Light vehicle traffic access to the mine facilities is from U.S. Highway 50 and traveling north on the existing Roberts Creek Road (Eureka County designation M-108) for approximately 13 miles, then west on the Bypass Road for approximately one mile to North Roberts Creek Road (Eureka County designation G-215), then northeast on North Roberts Creek Road for 0.6 mile, then northwest on North Roberts Creek Road for 1.5 miles to the proposed mine facilities.

The overall site plan is shown in Figure 15-1.



**Figure 15-1: Site Plan (McEwen, 2020)**

## **15.2 SERVICE ROADS**

Several access roads reach the leach pad and the process plant area as shown in Figure 15-2. Other service roads are around the process areas for access to the primary crusher, overland conveyor, and screen and agglomeration areas. All roads were designed for two-way traffic and vary in size depending on their usage.

## **15.3 PROCESS FACILITIES**

Near the crushing plant, a stockpile area exists that provides surge capacity between the mine and crusher. There is also a conveying system that moves crushed ore from the crusher to the leach pad and stacks it using a movable, grasshopper-type conveyor system.

The ADR process building is located immediately west of and adjacent to the Process Water Pond as shown in Figure 15-3. A bridge crane is included in the ADR facility to allow for optimal maintenance flexibility. In addition, an aisleway is included through the length of the building to allow for maintenance access throughout the facility.

The Refinery portion of the facility is secured. At the entry of the refinery a large vestibule is provided outside of the secure area that includes a space for operators to change in and out of their working clothes. An adjacent concrete paved area includes the carbon bed and dust collection systems, retort chiller, and exhaust fans for the secure area. The paved area outside of the refinery is fenced to include all of the equipment, less the retort chiller. The fenced area is gated to allow for secure loading of doré. The Electrical room for the ADR/Refinery facilities is also integral and included within the Refinery footprint. The ADR/Refinery facility also includes a designated maintenance area that is integral and open to the ADR facility but included in the refinery footprint.

To the north of the ADR building a reagent area is arranged directly against the building for ease of reagent distribution throughout the plant. This area includes an enclosed compressor room, and containments for the Nitric Acid, Caustic, and Cyanide tanks with a truck accessible bunded concrete apron for delivery containment.

The ADR and Refinery facilities are shown in Figure 15-3.

**GOLD BAR PROJECT**  
**FORM 43-101F1 TECHNICAL REPORT – FEASIBILITY STUDY**

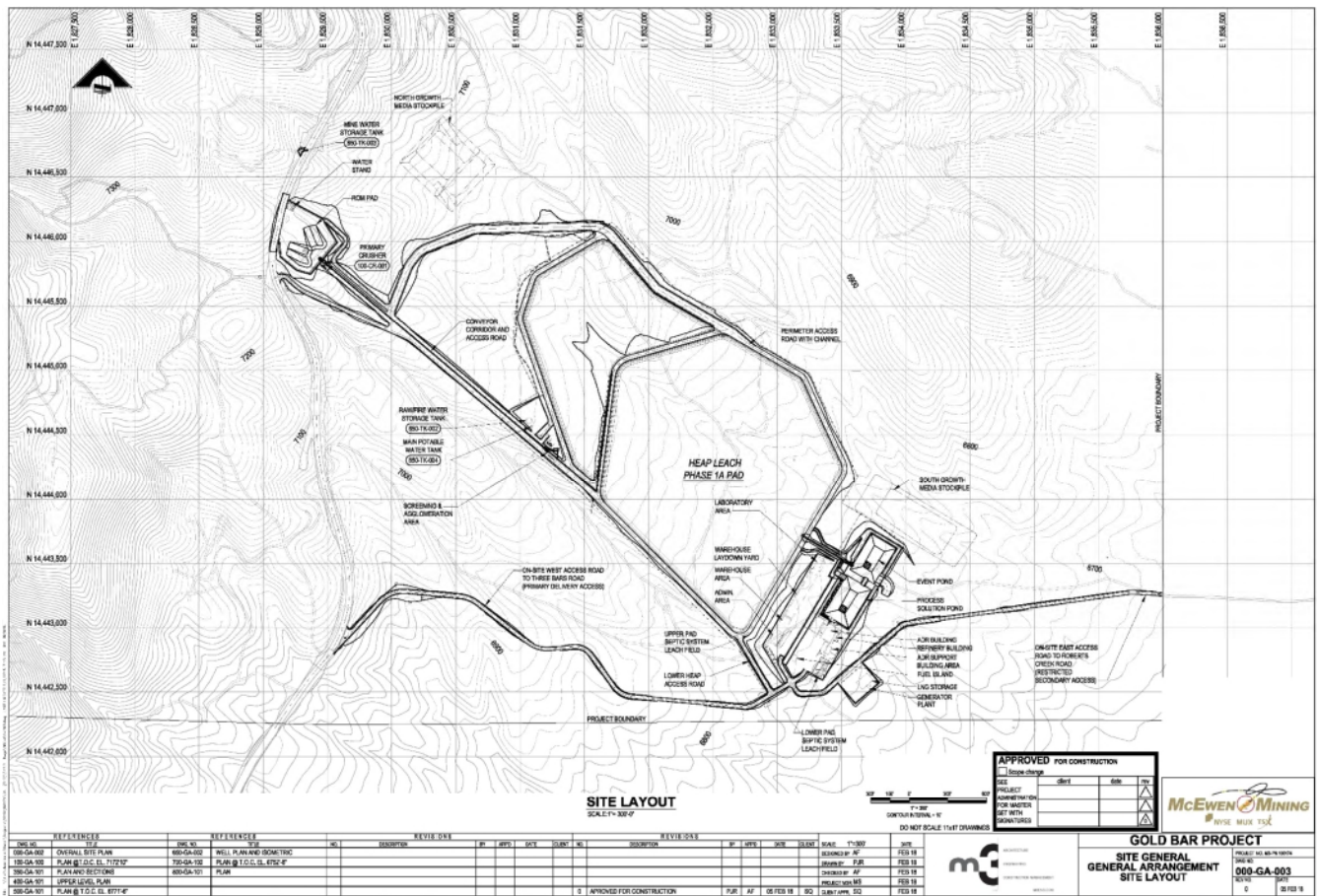


Figure 15-2: General Arrangement – Site Layout





#### **15.4 ANCILLARY FACILITIES**

The administration building is a 82' x 60' modular structure. It contains offices for administration, accounting, and human resources, as well as restroom facilities and a break room.

The ADR support building is a 42' x 59' modular structure. It contains offices, change areas, showers and restroom facilities for the process facility personnel.

A truck shop is provided by the contract miner; however, it is likely most maintenance will be performed by mobile units in the field.

#### **15.5 SEPTIC SYSTEMS**

Two septic systems are installed; one services the ADR/Refinery facility and the other services the administration, warehouse and laboratory facilities. The mine and agglomeration plant areas use portable toilets.

#### **15.6 POWER SUPPLY AND DISTRIBUTION**

Electric power is generated on site using two 1,333 kW and one 922 kW Liquid Natural Gas (LNG) fueled generators. The maximum demand load calculated for all crushing, screening, processing loads and supporting infrastructure (lab, administration, warehouse areas) at full capacity is 2,388 kW, with expected average utilization at 1,895 kW.

The generators are controlled by automatic switchgear that automatically start or remove generators as load demand increases or decrease. The switchgear automatically shares loads between on-line units as well as assures spare capacity and is available to start process equipment as needed.

A separate 240 kW diesel generator is located at the primary water well. This generator powers both water wells and the booster pumps required to lift water from the well head tank to the 450,000 gal water storage tank. This generator includes a self-contained diesel "day tank" which requires fueling on a daily basis. The same fuel truck that services the mining fleet is used to fuel this generator.

Power distribution within the Project area consists of a 4,160V overhead distribution line connecting the process facilities, offices and shop/warehouse buildings to the generators. Power is stepped down to 110/220V or 480V with transformers at the load locations as required. 480V power is run directly to the ADR support building from the ADR plant.

Uninterruptable power supplies are used to provide back-up power to critical control systems. This equipment is sized to permit operations to shut down and back up the computer and control systems and to facilitate start-up on restoration of normal generator power. Battery power packs supply back-up power to fire alarm systems and egress lighting fixtures.

Two 10,000 gal cryogenic fuel tanks for liquid natural gas storage are placed near the generators.

#### **15.7 WATER SUPPLY**

The peak make-up water requirement for the Project is approximately 450 gpm. The water source for the Project includes a primary production water well GBPW-210, located approximately one mile north of the Roberts Creek Ranch, and a secondary production water well GBPW-213, which is located approximately 1 mile south of the primary well. GBPW-210 is located approximately 2 miles from a 450,000 gal Raw/Fire Water Tank, located inside the Gold Bar Project boundary on the south side of the heap leach pad. The water well locations are shown on Figure 15-1.

A temporary construction water pond was built that has 1 million gallons of water capacity. This remains with the Project operation to provide further water supply.

Each production well is equipped with a submersible pump, pumping to an above-ground enclosed tank at the GBPW-210 site. Booster pumps are located adjacent to the tank. The system is designed for a maximum instantaneous flow of 500 gpm, and an average delivery of 305 gpm. The booster pumps transfer to the Raw/Fire Water Tank located above the Heap/ADR site at an elevation of approximately 6,970 ft. Electrical power for the wells and booster pumps are provided by a 240 kW diesel-powered generator.

The water supply feeding the Raw/Fire Water Tank also feeds a chlorination system and discharges into a potable water head tank. Potable water is distributed to the sanitary facilities in the buildings. Drinking water is supplied by a bottled water vendor.

The Raw/Fire Water Tank allows for distribution to the ADR processing plant and a fire water system.

A pump located at the Raw/Fire Water Tank area lifts water to a 25,000 gallon water tank located near the primary crusher. This tank supplies non-potable water for seasonal road watering as a dust control measure.

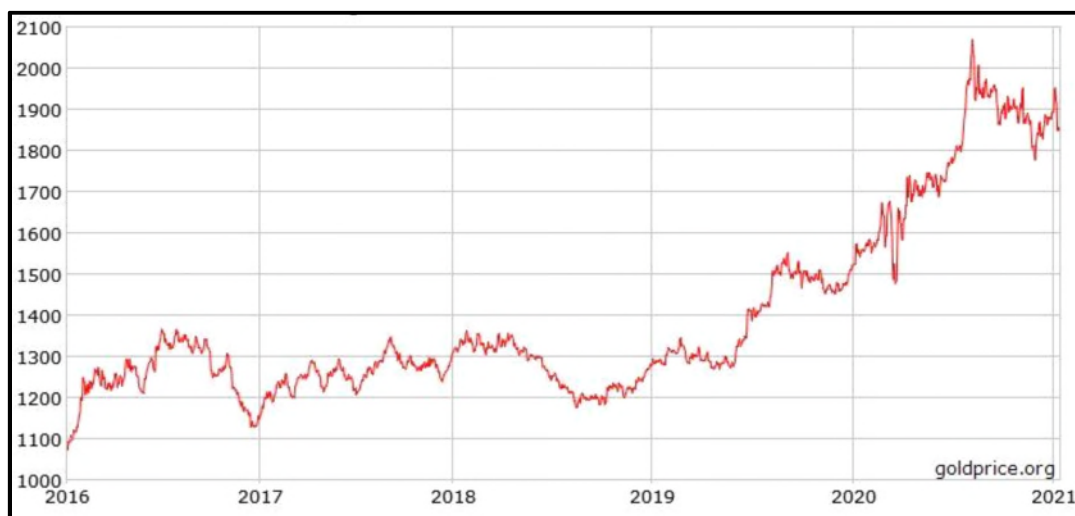
**16 MARKET STUDIES**

**16.1 GOLD MARKETS AND DEMAND**

The process facility proposed for this operation will produce gold doré bars between 90-99% purity. Gold bars will be weighed and assayed at the mine to establish value. The bars will be shipped regularly to a commercial refiner where their value will be verified. Sale prices are obtained based on world spot or London Metals Exchange market pricing and are easily transacted.

McEwen has a contract with Asahi Refining USA, Inc to smelt and refine its gold and silver doré bars. The contract was established in 2019. Payable metal is set at 99.95% for gold and 99.9% for silver. The contract also specifies transportation, insurance and refining charges.

Markets for gold are readily available. Gold markets are mature, global markets with reputable smelters and refiners located throughout the world. Demand has been stable from 2016 to 2020, with gold prices fluctuating mostly in the range of US\$1,150 to US\$2,000 per ounce of gold, refer to Figure 16-1. Marketing data used to determine the potential for economic extraction was obtained through industry sources and represents market information available in 2020. A gold price of \$1,650/troy ounce of gold was used to establish the base case economics for the Mineral Reserves, \$1,725/troy ounce was used for Mineral Resources.



**Figure 16-1: 5 Year Gold Price Fluctuation**

**16.2 METAL PRICE**

Metals prices used in this evaluation were based on a three-year rolling average for Gold, as at December 21, 2021. Analyst consensus for forward-looking median pricing for gold ranged from a minimum of \$1,610 to a maximum of \$1,792.

**Table 16-1: Gold Price Estimates US\$/troy ounce (Bloomberg, December 2021)**

| Date   | 2021 (actual) | 2022    | 2023    | 2024    |
|--------|---------------|---------|---------|---------|
| Median | \$1,799       | \$1,792 | \$1,720 | \$1,610 |

**17 ENVIRONMENTAL STUDIES, PERMITTING AND PLANS, NEGOTIATIONS, OR AGREEMENTS WITH LOCAL INDIVIDUALS OR GROUPS**

**17.1 REQUIRED PERMITS AND STATUS**

The Gold Bar Project is located approximately 30 miles northwest of the town Eureka, in the southern Roberts Mountains of Eureka County, Nevada. The location and current land ownership position mean that the mine is held to permitting requirements that are determined to be necessary by Eureka County, the State of Nevada, and the U.S. Department of the Interior, Bureau of Land Management, Battle Mountain District Office, Mount Lewis Field Office (BLM). All private land within the project is owned by Golden Pick LLC. The remainder of the land is federally owned public lands administered by the BLM. The list of permits, licenses, and authorizations for the Gold Bar Mine as provided by McEwen are presented in Table 17-1.

**Table 17-1: Potential Permits Required for the Gold Bar Mine**

| <b>Permit/Approval</b>   | <b>Issuing Authority</b>                     | <b>Permit Purpose</b>   | <b>Status</b>  | <b>Renewal/Term</b>   |
|--|--|---|--|---|
| <i><b>Federal Permits Approvals and Registrations</b></i>  |  |   |  |   |
| Mine Plan of Operations/National Environmental Policy Act (NEPA) Analysis and Record of Decision (RoD) | U.S. Bureau of Land Management               | Prevent unnecessary or undue degradation of public lands; Initiate NEPA analysis to disclose and evaluate environmental impacts and Project alternatives. | RoD and Plan approval received Nov 2017.   | Life-of Mine, unless changes to the Mine Plan of Operations are required. |
| Rights-of-Way (RoW) across public lands  | U.S. Bureau of Land Management               | Authorization grant to use a specific piece of public land for a certain Project, such as roads, pipelines, transmission lines, and communication sites   | All RoW's actions moved into MPO and approved Nov 2017.  | Life-of-Mine  |
| Explosives Permit  | U.S. Bureau of Alcohol, Tobacco and Firearms | Storage and use of explosives   | Required of all mining operations in Nevada that store and use explosives. Obtained by mining contractor operations.                               | Three-year term   |
| EPA Hazardous Waste ID No.   | U.S. Environmental Protection Agency (EPA)   | Registration as a small-quantity generator of wastes regulated as hazardous   | Required of all mining operations in Nevada that generates regulated hazardous wastes (e.g., lab wastes, etc.). In process; obtained August, 2018. | Life-of-Mine  |
| Notification of Commencement of Operations   | Mine Safety and Health Administration        | Mine safety issues, training plan, mine registration  | Required of all mining operations in Nevada. Completed.  | One-time notification   |
| Federal Communications Commission Permit   | Federal Communications Commission (FCC)      | Frequency registrations for radio/microwave communication facilities  | Required to use business radios to transmit on their own frequency   | Ten-year term   |

**GOLD BAR PROJECT**  
**FORM 43-101F1 TECHNICAL REPORT – FEASIBILITY STUDY**

| Permit/Approval  | Issuing Authority   | Permit Purpose   | Status  | Renewal/Term   |
|--|---|--|---|--|
| <b>State Permits, Authorizations and Registrations</b> |   |  |   |  |
| Nevada Mine Registry                                   | Nevada Division of Minerals   | Required operations registration   | Required of all mining operations in Nevada. Completed.   | One-time registration  |
| Surface Area Disturbance Permit                        | Nevada Division of Environmental Protection (NDEP)/Bureau of Air Pollution Control (BAPC) | Regulates airborne emissions from surface disturbance activities   | Required of all surface disturbance operations in Nevada over 5 acres. Completed; approved with Class II Air Permit, Aug 2017.  | Five-year term   |
| Air Quality Operating Permit                           | NDEP/BAPC   | Regulates Project air emissions from stationary sources  | Required for fugitive dust emissions and thermal emission units at lab and refinery. Issued Aug 2017. Revised 6/2/2020  | Five-year term   |
| Mercury Operating Permit to Construct                  | NDEP/BAPC   | Program to achieve mercury reduction via add-on control technologies.  | Required of all precious metal processing facilities with SIC codes “1041” or “1044”, with focus on mercury emissions from thermal processing units. Issued Aug 2017. Revised 9/24/2020 | Life-of-Mine, unless changes to the Mercury reduction facility are required. |
| Mining Reclamation Permit                              | NDEP/Bureau of Mining Regulation and Reclamation (BMRR)                                   | Reclamation of surface disturbance due to mining and mineral processing; includes financial assurance requirements       | Reclamation Plan submitted as part of federal MPO. Accepted under a Memorandum of Understanding (MOU) between the BLM and the NDEP. Issued Nov 2017. Revised 5/14/2019                  | Life-of Mine, unless changes to the Mine Plan of Operations is required.     |
| Mineral Exploration Hole Plugging Permit or Waiver     | Nevada Division of Water Resources (NDWR)   | Prevents degradation of waters of the State  | Required of all drilling operations in Nevada. Submitted and approved as part of monitoring and production well drilling.   | Per drilling program   |
| Water Pollution Control Permit (WPCP)                  | NDEP/BMRR   | Prevent degradation of waters of the state from mining, establishes minimum facility design and containment requirements | Required of all mining operations in Nevada. Completed; Issued Nov 2017. Revised 12/21/2018   | Renewal due Oct 2022   |

**GOLD BAR PROJECT  
FORM 43-101F1 TECHNICAL REPORT – FEASIBILITY STUDY**

| Permit/Approval  | Issuing Authority                      | Permit Purpose  | Status   | Renewal/Term   |
|--|--|---|--|--|
| <b>State Permits, Authorizations and Registrations</b>   |  |   |  |  |
| Approval to operate a Solid Waste System                 | NDEP/Bureau of Waste Management (BWM)  | Authorization to operate an on-site landfill  | Required for proposed on-site Class III waived solid waste landfill. Complete Q2 2018.   | Annual renewal                                       |
| Hazardous Waste Management Permit                        | NDEP/BWM                               | Management and recycling of hazardous wastes  | Required of all mining operations in Nevada that generates regulated hazardous wastes (e.g., lab wastes, etc.) Complete Q3 2018.                 | Annual renewal                                       |
| Permit to Appropriate Water/Change Point of Diversion    | NDWR                                   | Water rights appropriation  | McEwen has applied for and received an appropriation of 500 acre-feet annually under Water Right Permits 84546 and 84547.                        | Life-of-Mine. Proof of Beneficial Use filed annually |
| Permit to Construct a Dam                                | NDWR                                   | Regulate impoundment higher than 20 ft or impounding more than 20 acre-feet                       | Required if the final design of the process water ponds exceeds the 20/20 height or impoundment thresholds Complete; permit issued Oct 11, 2017. | One-time   |
| Potable Water System Permit                              | Nevada Bureau of Safe Drinking Water   | Water system for drinking water and other domestic uses (e.g., lavatories)                        | McEwen will need to apply for a potable water system permit. Permitting completed.   | Annual renewal                                       |
| Septic Treatment Permit<br>Sewage Disposal System Permit | NDEP/Bureau of Water Pollution Control | Design, operation, and monitoring of septic and sewage disposal systems                           | Required for proposed septic systems at the mine site. Permitting completed.   | Annual renewal                                       |
| Industrial Artificial Pond Permit                        | NDOW                                   | Regulate artificial bodies of water containing chemicals that threaten wildlife                   | Required of all mining operations in Nevada that utilize open process water ponds. Complete Q3 2018.   | Five year renewal, due June 2024.                    |
| Hazardous Materials Permit                               | Nevada Fire Marshall                   | Store a hazardous material in excess of the amount set forth in the International Fire Code, 2006 | Required for storage of fuels and lubricant at the Gold Bar site. Complete Q3 2018.  | Annual renewal                                       |
| <b>State Permits, Authorizations and Registrations</b>   |  |   |  |  |
| State Business License                                   | Nevada Secretary of State              | License to operate in the state of Nevada   | Required of all entities conducting business in the State of Nevada.   | Annual renewal                                       |

**GOLD BAR PROJECT  
FORM 43-101F1 TECHNICAL REPORT – FEASIBILITY STUDY**

| Permit/Approval                                  | Issuing Authority                          | Permit Purpose                      | Status  | Renewal/Term |
|--|--|-------------------------------------|---|--------------|
| <i>Local Permits for Eureka County</i>           |  |                                     |   |              |
| County Road Use and Maintenance Permit/Agreement | Eureka County Building Planning Department | Use and maintenance of county roads | McEwen has agreed to enter into Memorandum of Understanding (MOU) with Eureka Co. for road maintenance. |              |

Source: McEwen, 2020

**17.1.1 Federal Permitting**

A number of federal permits and authorizations are required for mining operations located on public land administered by a federal land management agency, the BLM. In the case of the Gold Bar Mine, the Project is partially located on public lands administered by the BLM for which McEwen controls unpatented mining claims. As such, the operation requires all of the identified federal permits, the most important of which are approvals of the 43 CFR § 3809 Mine Plan of Operations (MPO) and their subsequent NEPA analyses. BLM has approved the Mine Plan of Operations and NDEP has approved the Reclamation Permit application, and the final Record of Decision was received in November 2017, approving the EIS. Several amendments have been submitted and approved since then.

The Gold Bar South addition to the MPO is currently submitted and is under review by the BLM.

**17.1.2 State Permitting**

The State of Nevada requires a number of operational mining permits regardless of the land status of the Project (i.e., private, or public). The following are the principal state permits that have been approved for the Gold Bar Project:

- Water Pollution Control Permit (WPCP);
- Reclamation Plan;
- Air Quality Operating Permit; and
- Water Appropriations.

The WPCP and Air Quality Permit were approved in November 2017 and August 2017, respectively. The Reclamation permit was received in November 2017. Water rights sufficient for peak demand have been approved and are expected to last the life of the mine. Permits to change the point of diversion and place of use of the water rights have also been approved, for groundwater production wells within the MPO area on a portion of the Roberts Creek Ranch property.

Permits will be modified, as amendments to existing permits, as required to allow the addition of the Gold Bar South portion of the project. These amendments will cover the WPCP, Reclamation plan and the Air Quality permit to allow the construction of haulage and access roads, waste dumps and permit operations.

**17.1.3 Local Permitting**

A Memorandum of Understanding (MOU) between McEwen and Eureka County for continued road maintenance is in effect for the Gold Bar Project.

**17.2 ENVIRONMENTAL ISSUES**

A Final Environmental Impact Statement (FEIS) was prepared, and a Record of Decision was issued for the Gold Bar Project on November 7, 2017. The FEIS analyzed impacts to potentially affected resources from the Project. The Project includes Environmental Protection Measures (EPMs), as well as mitigation measures, which were designed to



avoid and/or minimize environmental impacts to resources potentially affected by the Project. A complete analysis of potential impacts to resources (including air quality, cultural resources, vegetation, water quality, quantity and geochemistry, and various wildlife species), as well as the EPMs and mitigation measures designed to avoid and/or minimize impacts can be found in the FEIS that was prepared for the Project (BLM, 2017).

An amended Mine Plan of Operations (MPO) was filed to incorporate the proposed expansion of mining operations into the Gold Bar South (GBS) area. The MPO envisions mining from open pits in the GBS area, a haul road to allow ore transport to the existing Gold Bar heap leach pad, waste rock dumps and associated EPMs to protect the environment. This MPO was submitted to the Bureau of Land Management September 25, 2020. A Record of Decision is expected in Q2 2022.

The sage grouse mitigation plan includes looking for opportunities to increase habitat during reclamation and reducing noise during mating season. Operational constraints to mitigate noise have been implemented in the mine plans and are reflected in the current production schedules.

### **17.3 SOCIAL AND COMMUNITY ISSUES**

A number of social and community concerns were addressed in the initial and subsequent amendments to the MPO. Those include Wildlife, Wild Horses and Livestock, Cultural Resources, Public Safety and Accessibility, Protection of Visual Resources, Health and Safety and Emergency Response and Paleontological Resources.

McEwen has committed to protection of the migratory birds and Greater Sage Grouse through avoidance of nesting sites, noise reduction and travel/road maintenance restrictions on access roads during sage grouse mating and nesting season (March 1 – May 15), employee and contractor training specifically related to bird protection measures, and wildlife monitoring.

Wild Horses and Livestock will be protected through similar measures, including identification and signage of trails used by horses and livestock, use of specialized reflectors to reflect oncoming headlights to the trails to startle, and prevent animal crossings, cooperation with the BLM on monitoring and notification, and employee and contractor training on mitigation measures.

Cultural and Paleontological Resources will be avoided when possible as this is a BLM preferred management response. Otherwise, McEwen will work with the local Duckwater Tribe, BLM, and Nevada State Historic Preservation Office (SHPO) to manage those resources, in accordance with prescribed standards and guidelines.

McEwen will manage Public Safety and Accessibility by ensuring all activities will be conducted in conformance with applicable federal and state health and safety requirements. Public access control points will be established where pre-existing roads and trails enter the active mining areas to ensure public safety is maintained.

Visual Resources will be protected using reduced light emissions from the facility and equipment, painting buildings with BLM-approved paint colors and reduction of fugitive dust. The Pony Express trail traverses through the Gold Bar Project near the Gold Bar South property. McEwen will protect the viewshed from the trail through the use of reclamation that matches the previous landscape.

The development of the Project will comply with environmental and health and safety regulations of all governmental agencies, including, but not limited to the Mining Safety and Health Administration (MSHA), NDEP, the Nevada Division of Industrial Relations - Mine Safety and Training Section (NDR), the Nevada State Engineer's Office (SEO), and the Nevada Bureau of Mines and Geology (NBMG).

No other plans, negotiations, or agreements with local individuals or groups are required for the operation of the Gold Bar Project.

**17.4 CONCLUSIONS**

No significant environmental, social or community issues exist currently at the Gold Bar Project or are expected to materially impact the development of the Gold Bar South addition to the project.

## **18 CAPITAL AND OPERATING COSTS**

### **18.1 INTRODUCTION**

McEwen began construction on Gold Bar in November 2017 and plant commissioning was completed in Q1 2019. Life of mine sustaining capital projections total \$19.5M consisting of \$10.9M for leach pad expansion, \$3.0M for Gold Bar South construction and \$5.6M for other sustaining capital.

#### **18.1.1 Currency**

All values are expressed in US dollars.

### **18.2 OPERATING COSTS**

The actual 2021 operating cost of \$1,753/oz. (unaudited) was adversely affected by higher mining rates and productivity problems from the former mining contractor which operated at Gold Bar until mid Q4 2021. The LOM average forecasted operating costs are summarized in Table 18-1.

**Table 18-1: LOM Cost Summary**

| <b>Area</b>        | <b>\$ per Au ounce</b> | <b>\$ per ton ore</b> |
|--------------------|------------------------|-----------------------|
| Mining             | \$769                  | \$13.14               |
| Processing         | \$239                  | \$4.09                |
| G&A                | \$189                  | \$3.23                |
| <b>Total Costs</b> | <b>\$1,297</b>         | <b>\$20.46</b>        |

Reclamation costs are estimated based on the Nevada Standardized Reclamation Cost Estimator (SRCE) and standardized cost data. The total reclamation cost is included for the closure and reclamation of the existing mining operations, the majority of the historic Atlas mining disturbances, and the yet to be developed Gold Bar South operations. The total reclamation cost is estimated at \$16.9M and is included in the cash flow calculation.

### **18.3 MINING COSTS**

#### **18.3.1 Basis of Mining Capital Cost Estimate**

The Gold Bar Project consists of existing pits and haulage infrastructure. Modifying the existing roads would require extensive earthworks and permitting efforts. The capital cost for modifying the existing roads is included for all access roads within the mining areas. The cost for road pioneering may increase or decrease when the contracts are finalized.

In late 2021, Ledcor Group replaced the previous mine contractor. The contracted costs with Ledcor have been incorporated into the mine operating and capital costs estimates.

The contractor mining costs include:

1. All mine mobile equipment required to drill, blast, load, and haul the material from the pit to the appropriate destinations.
2. Auxiliary equipment to maintain the mine and material storage areas in good working order as well as construct the mine haul roads and maintain them.
3. Equipment to maintain the mine fleet such as tire handlers and forklifts.
4. Explosives equipment; explosive magazines, prill silos, ANFO truck(s) and skid steer.

5. Light vehicles for mine operations and staff personnel.
6. Equipment replacements are included as required based on the useful life of the equipment.
7. Road Pioneering, rehab, and widening.

The contractor mining costs do not include:

- 1) Mine office buildings, or shop facilities.
- 2) Mobile equipment that is not required by the mine (i.e., no mobile units for the plant).
- 3) Permitting costs.
- 4) Infrastructure or process plant related costs.
- 5) Mine communication network & system.
- 6) Mine engineering equipment (computers, survey equipment etc.).
- 7) Upgrading the road to Gold Bar South.

### **18.3.2 Mining Development and Operating Costs**

Mine operating costs are based on a US\$/ton moved basis, were developed from budgetary quotes provided to IMC by McEwen. The quote includes operating costs for the following: fuel and lube, tires, overhaul and maintenance parts, wear items, and diesel fuel. A breakdown of contractor unit rates is shown in Table 18-2. Ledcor Group is currently contracted and working on site for road pioneering and mining efforts.

**Table 18-2: Operating Costs for Mining Area**

| <b>Mining Area</b> | <b>Ore (\$/ton)</b> | <b>Waste (\$/ton)</b> |
|--------------------|---------------------|-----------------------|
| Pick               | \$3.29              | \$2.57                |
| Ridge              | \$4.16              | \$2.31                |
| Gold Bar South     | \$3.57              | \$2.14                |

The mining costs above include an allowance to cover the owner's cost for fuel, blasting, assaying and engineering staff, which was applied at \$0.62/t mined.

## **19 ECONOMIC ANALYSIS**

### **19.1 INTRODUCTION**

The financial evaluation presents the determination of the Net Present Value (NPV) for the project. Annual cash flow projections were estimated over the life of the mine based on the estimates of capital expenditures, production cost, and sales revenue, on a current cost basis. The sales revenue is based on the production of gold doré. The estimates of capital expenditures and site production costs have been developed under the direction of McEwen specifically for this project and have been presented in earlier sections of this report.

### **19.2 MINE PRODUCTION STATISTICS**

Mine production is reported as ore and waste from the mining operation. The annual production figures were obtained from the mine plan as reported earlier in this report.

The life of mine ore and waste quantities and ore grade are presented in Table 19-1.

**Table 19-1: Life of Mine Ore, Waste and Metal Grades**

|            | <b>Tons (000's)</b> | <b>Gold oz/t</b> |
|------------|---------------------|------------------|
| Ore Tons   | 15,491              | 0.024            |
| Waste Tons | 60,768              |                  |

### **19.3 PLANT PRODUCTION STATISTICS**

Ore will be crushed, screened, conveyed, and placed on a heap leach and processed in an ADR carbon plant and will produce gold doré. Agglomeration will only be used for a limited amount of high clay ores. A portion of the ore will be ROM, placed on the heap leach pad without additional crushing/screening.

The estimated average metal recoveries are presented in Table 19-2.

**Table 19-2: Average Metal Recovery Factors**

|                        | <b>Gold %</b> |
|------------------------|---------------|
| Metallurgical Recovery | 72.0          |

Estimated life of mine gold doré production is presented in Table 19-3 with the approximate metal contained.

**Table 19-3: Life of Mine Production Summary**

|              | <b>Gold (kcozs)</b> |
|--------------|---------------------|
| Gold to Doré | 260.2               |

#### **19.3.1 Smelter Return Factors**

Gold doré will be shipped from the mine site to a refining company. Transportation and refining charges are based on the current agreement with the refiner and are shown below.

**Table 19-4: Refining Terms**

| <b>Doré</b>                                     |         |
|---|---------|
| Payable gold                                    | 99.95 % |
| Transportation and Refining charge – Au (\$/oz) | \$2.01  |

**19.4 CAPITAL EXPENDITURE**

**19.4.1 Initial and Sustaining Capital**

The total capital carried in the financial model for sustaining capital is discussed in Section 18. The original capital is considered as a sunk investment.

**19.4.2 Working Capital**

A delay of receipt of revenue (15 days) from sales is used for accounts receivables. A delay of payment for accounts payable of 30 days is also incorporated into the financial model.

**19.4.3 Salvage Value**

An allowance for salvage value has been included in the cash flow analysis and estimated to be \$5.15 million. This value was estimated by McEwen as at March 31, 2020.

**19.5 REVENUE**

Annual revenue is determined by applying estimated metal prices to the annual payable metal estimated for each operating year. Sales prices have been applied to all life of mine production without escalation or hedging. The revenue is the gross value of payable metals sold before treatment and transportation charges.

The metal sales price used in the evaluation is as follows:

- Gold \$1,650.00/troy ounce

**19.6 OPERATING COST**

Table 19-5 shows the estimated life of mine on-site operating cost by area per ton of ore processed and per ounce produced.

**Table 19-5: LOM Site Average Operating Cost Summary**

|  | <b>Cost per Ton of Ore Processed</b> | <b>Cost per Ounce Produced</b> |
|--|--------------------------------------|--------------------------------|
| Mining   | \$13.14                              | \$769                          |
| Process  | \$4.09                               | \$239                          |
| G&A  | \$3.23                               | \$189                          |
| <b>Total Site Operating Cost<sup>(1)</sup></b> | <b>\$20.46</b>                       | <b>\$1,197</b>                 |

Notes:

1. Site Operating cost is calculated by dividing total life-of-mine on-site production costs by total ounces produced.

### **19.6.1 Total Production Cost and All-in Sustaining Cost**

The average Production Cost over the life of the mine is estimated to be \$20.46/t of ore processed or \$1,197 per ounce of gold. Total Production Cost includes Total Site Operating Cost, refining, royalties, Net Proceeds Tax, salvage value, and reclamation and closure costs.

The All-in Sustaining Cost is estimated to be \$23.24/t of ore processed or \$1,360 per ounce of gold. The All-in Sustaining cost is calculated by dividing the Total Production Cost and the LOM sustaining capital cost by total ounces produced.

#### **19.6.1.1 Royalty**

No royalties accrue to the Ridge or Pick deposits. There is a royalty of 1% NSR on the ore from Gold Bar South. The LOM estimate for the Gold Bar South royalty is \$0.7 million.

#### **19.6.1.2 Depreciation**

Depreciation is calculated using the MACRS straight-line method starting with first year of production for both the initial capital and sustaining capital.

#### **19.6.1.3 Reclamation & Closure**

An allowance for the cost of final reclamation and closure of the property, including the Gold Bar South expansion, has been included in the cash flow analysis and is estimated to be \$16.9 million.

### **19.7 TAXATION**

A net proceeds tax payable to the state of Nevada is approximately \$11.2 million for the life of the mine.

An excise tax on the gross revenue payable to the state of Nevada is approximately \$2.4 million for the life of the mine.

Corporate income taxes paid is estimated to be zero, as a loss carry forward in excess of \$150 million (provided by McEwen) is being applied to net income.

### **19.8 PROJECT FINANCING**

For the purposes of this study, it is assumed investment in the Gold Bar mine will be equity financed or with funds taken from operating income.

### **19.9 NET INCOME AFTER TAX**

Net Income after Tax is approximately \$72.2 million for the life of the mine.

### **19.10 NET PRESENT VALUE**

The base case economic analysis indicates that the project has an NPV at 8% discount rate of \$57.2 million. The payback period and IRR were not calculated as this is an ongoing operation. An upside case is presented in Table 19-6 where the gold price is increased to \$1,800 per ounce.

**Table 19-6: Sensitivity Analysis after Taxes**

|   | <b>Base Case<br/>\$1,650/oz gold</b> | <b>Upside Case<sup>(4)</sup><br/>\$1,800/oz gold</b> |
|---|--------------------------------------|--|
| <b>NPV (5% Discount Rate)<sup>(2)</sup></b>   | \$62.2 million                       | \$95.1million  |
| <b>NPV (8% Discount Rate)<sup>(2)</sup></b>   | \$57.2 million                       | \$87.7 million                                       |
| <b>Average Annual Cash Flow<sup>(3)</sup></b> | \$12.0 million                       | \$18.3 million                                       |
| <b>Average Margin to Cash Costs</b>           | \$453/oz                             | \$603/oz   |
| <b>Average Margin to AISC</b>                 | \$290/oz                             | \$434/oz   |

Notes:

1. "oz" means Troy ounce(s);
2. NPV is discounted to January 1, 2022.
3. Average Annual Cash Flow during production years.
4. Upside Case may not capture impact from taxes after the loss carryforward is consumed

## 19.11 SENSITIVITIES

Additional sensitivities to gold price, sustaining capital, operating costs and recovery were also modeled. Those sensitivities are displayed in Table 19-7.

**Table 19-7: Sensitivity Analysis after Taxes to Various Factors**

|                                | <b>Gold Price</b> |                                    |             | <b>Capex</b>    |                   |             |
|--------------------------------|-------------------|------------------------------------|-------------|-----------------|-------------------|-------------|
|                                | <b>15%</b>        | <b>Base<br/>(\$1650/oz<br/>Au)</b> | <b>-15%</b> | <b>15%</b>      | <b>Base</b>       | <b>-15%</b> |
| <b>NPV5% (\$ millions)</b>     | \$116.5           | \$62.2                             | \$7.8       | \$59.4          | \$62.2            | \$64.9      |
| <b>Cash Flow (\$ millions)</b> | \$134.3           | \$72.2                             | \$10.0      | \$69.3          | \$72.2            | \$75.1      |
|                                | <b>Opex</b>       |                                    |             | <b>Recovery</b> |                   |             |
|                                | <b>15%</b>        | <b>Base</b>                        | <b>-15%</b> | <b>74%</b>      | <b>Base (72%)</b> | <b>70%</b>  |
| <b>NPV5% (\$ millions)</b>     | \$20.3            | \$62.2                             | \$104.1     | \$72.8          | \$62.2            | \$51.6      |
| <b>Cash Flow (\$ millions)</b> | \$24.5            | \$72.2                             | \$119.8     | \$84.3          | \$72.2            | \$60.1      |



## **20 ADJACENT PROPERTIES**

There are no significant properties adjacent to the Gold Bar property.

## **21 OTHER RELEVANT DATA AND INFORMATION**

There is no other relevant data and information or explanation necessary to make the technical report understandable and not misleading.

## **22 INTERPRETATION AND CONCLUSIONS**

Conclusions for this Technical Report are described in the following subsections.

### **22.1 EXPLORATION**

- Several exploration opportunities are recognized in the district to continue to discover and increase mineral resources.
- Near-mine opportunities include conversion of inferred mineral resources within the existing resource models, and expansion of mineral resources adjacent to currently defined pit limits.
- Other areas of known mineralization exist proximal to existing infrastructure.

### **22.2 METALLURGY AND RECOVERY**

- Additional test work and a change in the processing strategy since 2018 to include greater ROM placement has resulted in a modified heap leach recovery projection for the Gold Bar North Deposit from 82% to 78% for crushed ore and 72% for ROM.
- Recent testing on ore from Gold Bar South suggests an expected recovery of 61% for material placed as ROM.

### **22.3 MINERAL RESOURCE ESTIMATE**

- The 2021 Statement of Mineral Resources for the Project using a variable cut-off grade is 1,479 Mt at 0.056 oz/t Au of Indicated Resources resulting in 82.4 koz Au, and an additional 2.0 Mt at 0.023 oz/t Au of Inferred Resources resulting in 44.4 koz Au, with an effective date of 1 January 2022. Measured Resources were reclassified as Indicated based on on-going work to determine density values and mineralogy that could potentially affect recovery. Mineral Resources are exclusive of Mineral Reserves.
- The data set underlying the mineral resource estimate has been validated. Though driven primarily by reverse circulation drilling, recent core and RC drilling campaigns at Pick and Gold Bar South have confirmed historic intercepts and provided additional constraints and confidence in gold grades and grade continuity in the deposits.
- Distribution of oxide and non-oxide mineralization within the Pick, Ridge and Cabin deposits is extraordinarily complex. The overall quantum of metal is robust, but physical location of mineralization will need to be confirmed at the mining scale using blast-hole drilling results and grade control modeling along with additional infill RC and core drilling in key areas of Pick and Gold Ridge to identify deleterious mineralization and structural controls.
- Pick, Gold Ridge, Cabin and GBS resources require additional drilling and test work to support conversion to Measured resource and conversion to reserves. The deposit appears to be amenable to heap leach and ADR processing. Material densities are a deficiency that needs test work to reduce potential tonnage error and improve classification confidence. Continued testing of deleterious minerals is also necessary to properly route material that may influence recovery from heap leach operations.

### **22.4 MINERAL RESERVE ESTIMATE**

- The 2022 Statement of Mineral Reserves for the Gold Bar Project, using a variable cut-off grade depending on process, is 15.5 Mt at 0.024 oz/t of Probable Mineral Reserves or 370 koz of contained gold.
- The final pit design and the internal phase (pushback) designs were guided by the results of the Lerchs-Grossmann (LG) algorithm. The final pit design is based on pit economics between \$1,250/oz & \$1,400 LG pits. The mineralization within the final pit geometry was then tabulated using the \$1,650/oz gold price which

results between 0.0065 oz/t to 0.0300 oz/t cut-off grade, depending on source, material type and process type.

- The mine plan assumes that the mine operator will be able to selectively mine the ore zones. The model has estimated carbonaceous, clay content, and other low recovery zones are known to impact recoveries and resulting haulage destination. Adjustments to the modeled zones of carbon, low-recovery and/or clay content could have positive or negative impacts to the project. Multi-factored identification of material is often difficult to successfully achieve at operations. Correctly identifying and segregating the various zones during mining activity will be a key factor impacting the project economics. The multi-factored identification of various zones is a project risk and should be mitigated with a rigorous ore control program.

## **22.5 MINING**

- The Gold Bar project is planned for production using conventional hard rock open pit mining methods. The Gold Bar Project is currently and will continue being mined by a contractor. Contractor equipment on hand is often variable. There is flexibility in the fleet size and the actual mining fleet will likely vary depending on the contractor's fleet on hand. The schedule and production requirements were based on 20 ft benches.
- The multiple schedules were evaluated on a NPV basis at the project design prices that were used to establish the mineral reserve.
- The mine production schedule was developed with the goal of loading the leach pad at the required production rates and maximizing the project return on investment. Multiple mine production schedules were developed that analyzed alternative cut-off grade strategies versus mine total material movement.

## **22.6 PROJECTED ECONOMIC OUTCOMES**

- The estimated life of mine sustaining capital costs of \$19.5 million and operating costs of \$20.46 per ton processed are reasonable estimates based on comparisons to similarly sized options. The average All-in Sustaining Cost over the life of the mine is estimated to be \$23.24/t of ore processed and or \$1,360 per ounce of gold.

## **22.7 RISKS**

- Gold prices are volatile and there is no guarantee that McEwen will receive the gold price as used in the economics.
- Carbonaceous materials, both refractory and preg robbing exist in the deposit. This material, though commonly mineralized above cut-off grade, has assigned a lower recovery factor in the resource model and will require close attention during the ore control process to separate it from leach ore.
- Sulfidic mineralization is present in localized areas associated with faulting and fracturing. This material, though commonly mineralized above cut-off grade, has been assigned a lower recovery factor in the resource model and will require close attention during the ore control process to separate it from the leach ore.
- It is possible that weather could affect operations. Current assumptions for downtime due to weather are 15 days per year.
- The cost of consumables (such as cyanide and LNG) could change.

## **22.8 OPPORTUNITIES**

- The recovery projection of 61% for ROM ore from GBS is conservative compared to the range of recovery from metallurgical test work. Both the leaching kinetics and the overall recovery have potential to exceed expectation based on test work.

- Further test work is underway to evaluate the optimum size of ore to be placed on the leach pad and the recoveries of those ores. This test work will allow the calculation of the most economic mix of crushed and ROM ores to be processed.
- The exploration drilling density and geotechnical guidance within Ridge is not as well defined as Pick and Gold Bar South. Future drilling campaigns at Ridge may improve grade estimation and reduce stripping requirements.
- Permitting for GBS could allow an improvement in the schedule for additional production.
- There remains exploration potential proximal to current pit boundaries for all the deposits discussed in this report. A follow up drilling program will continue to test the limits of the known resources to evaluate mine life growth.

## **23 RECOMMENDATIONS**

### **23.1 RECOMMENDED WORK PROGRAMS AND COSTS**

#### **23.1.1 Exploration**

Execute a systematic exploration program consisting of geologic mapping, geochemistry, and geophysics to evaluate and expand areas of known mineralization proximal to current mineral resources and follow up on areas with known indicators of mineralization throughout the district. The estimated program cost for this program is \$500,000.

#### **23.1.2 Metallurgy and Recovery**

- A study of the optimum processing method based on the need for crushing and most economic size to place on the leach pad should be undertaken. This study should evaluate any potential changes to the crushing circuit to improve throughput, if needed. Test work to support this study is underway. The estimated cost for this program is \$250,000.

#### **23.1.3 Pick and Gold Ridge Deposits**

- Additional sampling for density in the Pick, Ridge, and Cabin deposits is recommended. This would require triple tube core drilling of approximately 40 holes. These holes which will average 400 ft each and cost \$100/ft for drilling and testing, have an estimated program cost of \$1,600,000.
- Additional analytical testing for Organic Carbon and Sulfide Sulphur is recommended for all deposits prior to and during ore control. Additional analytical testing of the density core program is estimated to cost \$80,000. Additional RC drilling should include 20 holes averaging 500 ft at an estimated cost of \$60/ft for drilling and testing for an estimated program cost of \$600,000.
- The geotechnical data for Gold Ridge is primarily based on a single drill hole. More geotechnical work should be performed prior to construction at Ridge to determine if a steeper slope angle can be achieved. An increase in the pit slope will reduce waste stripping and allow earlier access to ounces within Ridge. A total of four HQ diameter, oriented core holes are recommended. These holes, which will average 500 ft each at a cost of \$100/ft for drilling and testing, have an estimated program cost of \$200,000.

#### **23.1.4 Gold Bar South**

##### **23.1.4.1 Metallurgy and Recovery Confirmation**

Recovery variability by rock type and alteration should be a continual focus of internal and external metallurgical testing. Additionally, sensitivity to crush size should be periodically examined to identify possible routs to enhance gold recovery or optimize costs. Dedicated samples should be obtained through diamond drill holes, ideally PQ core size, or from test pits if suitable mineralized material is available near surface. The laboratory tests should allow a proper confirmation of recovery as function of material type, head grade, irrigation solution concentration, and to develop the geotechnical parameters for heap leaching. Test work will be a combination of variability bottle roll tests, dedicated column tests, and compacted permeability tests.

##### **23.1.4.2 Geochemical Characterization for Permitting and Closure**

Geochemical characterization of ore and waste for future mining can be achieved by utilizing materials drilled in the geotechnical and metallurgical drilling programs recommended herein; therefore, no dedicated drilling costs are needed. Additional costs of approximately \$75,000 should be budgeted for acid-base accounting and humidity cell testing along with program design and monitoring.

## **24 REFERENCES**

- Atlas Corporation, 1994, Mine to Mill Reconciliation, Historical Production. Document from Atlas Corp. files, undated but 1994 or later.
- Atlas Corporation, 1996, Gold Bar Review. Report prepared by Atlas Corporation staff, March, 1996.
- Broili, C., French, G.M., Shaddrick, D.R., and Weaver, R.R., 1988, Geology and gold mineralization of the Gold Bar deposit, Eureka County, Nevada, in Schafer, R.W., Cooper, J.J., and Vikre, P.G., eds., Bulk mineable precious metals deposits of the western United States. Symposium proceedings: Reno, Geological Society of Nevada, p.57-72.
- Bureau of Land Management (BLM), 2017. Gold Bar Mine Project Final Environmental Impact Statement (Case File NVN-091037). U.S. Department of the Interior, Bureau of Land Management, Mount Lewis Field Office, Battle Mountain District. October 2017.
- Bureau of Land Management (BLM), 2017a. “BLM Issues Decision on Environmental Impact Statement for McEwen Mining Gold Bar Project, Eureka County.” Released 7 November 2017. Accessed 28 March 2018. <https://www.blm.gov/press-release/blm-issues-decision-environmental-impact-statement-mcewen-mining-gold-bar-project>
- Canadian Institute of Mining, Metallurgy and Petroleum Council, 2014, CIM Definitions Standards for Mineral Resources and Mineral Reserves: [www.cim.org](http://www.cim.org). Updated May, 2014
- French, G.M., Fenne, F.K., Maus, D.A., Rennebaum, T.D., and Jennings, T.A., 1996, Geology and mineralization of the Gold Bar district, southern Roberts Mountains, Eureka County, Nevada in Green, S.M. and Struhsacker, E., Eds., Geology and Ore Deposits of the American Cordillera, Field Trip guidebook compendium, Geological Society of Nevada, Reno, Nevada, P. 309-305.
- Hall, Roger M., 1989, Preliminary Report: Afgan 88/89 exploration drilling: Internal report for the Lyle Campbell Trust, 4 pages.
- Hall, Roger M., 1990, Afgan 1989/90 exploration/assessment report: Internal report for the Lyle Campbell Trust, 3 pages.
- Heberlein, David, 2017, An Investigation of Historical Soil Geochemistry Results, Gold Bar Project, Nevada: Report to McEwen Mining Inc, November 23<sup>rd</sup>, 2017.
- Heberlein, David, 2018, An Investigation of Historical Soil Geochemistry Results, Gold Bar Project, Nevada – An Update: Report for McEwen Mining Inc, August 27, 2018.
- Heberlein, David, 2019, An Investigation of <sup>13</sup>C and <sup>18</sup>O Stable Isotope Results of Drill Hole Pulp Samples, Gold Bar Project, Nevada: Report to McEwen Mining Inc, September 12<sup>th</sup>, 2019.
- Hurban, G. K., 1999, Geology and exploration targets of the Afgan property, Eureka County, Nevada: Report to White Knight Gold (U.S.), Inc., December 3, 1999, 15 p. and accompanying geologic map.
- M3, 2018, Gold Bar Project Form 43-101F1 Technical Report Feasibility Study, Eureka County, Nevada: Prepared for McEwen Mining Inc, March 30, 2018.
- IMC, 2018, Gold Bar Project Form 43-101F1 Technical Report Feasibility Study, Eureka County, Nevada: Prepared for McEwen Mining Inc, March 30, 2018.

**GOLD BAR PROJECT**  
**FORM 43-101F1 TECHNICAL REPORT – FEASIBILITY STUDY**

---

IMC, 2020, Written Communication from International Mining Consultants

Janney, D. W., 1986, Afgan project report: Internal memo to David C. Fitch, Hecla Mining Company, August 11, 1986, 2 pages.

Kastelic, Robert L., Watson, John D., and Guerard, Sylvain, 2020, Reactivating a Historical District: Exploration and Development of the Gold Bar Project, Eureka County, Nevada in Kautz, F. R., and Pennell, W. M., eds.: Vision for Discovery: Geology and Ore Deposits of the Basin and Range, Geological Society of Nevada 2020 Symposium Proceedings, pp. 901-917.

KCA, 2011a. Kappes, Cassiday & Associates (2011a). Gold Pick Project, Report of Metallurgical Test Work, April 2011, Prepared for US Gold Corporation, April 14, 2011.

KCA, 2015. Kappes, Cassiday & Associates (2015). Gold Bar Project, Report on Metallurgical Test Work, August, 2015, Prepared for McEwen Mining Inc., KCA Report I.D. 140160\_GB01\_01. August, 2015.

KCA, 2017. Gold Bar Project, Column Composite, Report of Metallurgical Test Work. Prepared for McEwen Mining. Prepared by Kappes, Cassiday & Associates. Report I.D.: KCA0160066\_GB04\_02. May 2017.

Koehler, B. M., 1994b, A progress report on the geology and mineralization of the Afgan property, Eureka County, Nevada: Great Basin Exploration and Mining Co., Inc. report, February 1994, 6 p.

Koehler, B. M., 1995, Afgan mineral prospect annual report – 1994: Great Basin Exploration & Mining Co., Inc. report, January 31, 1995, 6 p.

Long, S. P., Henry, C. D., Muntean, J. L., Edmondo, G. P., and Cassel, E. J., 2014, Early Cretaceous construction of a structural culmination, Eureka, Nevada, USA – Implications for out-of-sequence deformation in the Sevier hinterland: Geosphere, v. 10, no. 3; pp.564-584.

M3, 2018, Gold Bar Project Form 43-101F1 Technical Report Feasibility Study, Eureka County, Nevada: Prepared for McEwen Mining Inc, March 30, 2018, 255 p.

MDA, 2004. Technical report, Afgan project, Eureka County, Nevada USA: Report prepared by Mine Development Associates for Castleshorth Ventures Inc., 73 p. plus appendices.

MDA, 2006, Technical Report for the Gold Pick and Gold Ridge North Deposits, Eureka County, Nevada, prepared by Mine Development Associates for Quito Gold Corporation, a wholly owned subsidiary of White Knight Resources Ltd., dated April 3, 2006; effective date December 32, 2005, 118 p. plus appendices.

MDA, 2011. Updated Technical Report for the Afgan-Kobeh Project, Eureka Nevada; Prepared by Mine Development Associates for NV Gold Corporation, June 13, 2011. Effective Date May 9, 2011, 93 p.

Midway Gold Corp., 2008a, Midway drills shallow gold at Afgan, Nevada: News release dated February 21, 2008, 2 p.

Midway Gold Corp., 2008b, Afgan 2007 annual report: Campbell Trust: Report prepared for Lyle F. Campbell Trust.

Midway Gold Corp., 2009, Afgan 2008 annual report dated January 23, 2009, prepared for Gold Standard Royalty (formerly Lyle Campbell Trust) 76 p.

Mateer, Melissa, 2018, Spectral Analysis of the Gold Bar Mine, Eureka, NV: Report prepared by Mateer Consulting for McEwen Mining Inc dated June 8th, 2018.



**GOLD BAR PROJECT**  
**FORM 43-101F1 TECHNICAL REPORT – FEASIBILITY STUDY**

---

- Mateer, Melissa, 2019, Geospectral Solutions, written communication, 2019
- Muntean and Cline, 2018, Diversity of Carlin-Style Gold Deposits, Reviews in Economic Geology, Society of Economic Geologists, Inc, Volume 20, 363 p.
- Murphy, M. A., and Gronberg, E. C., 1970, Stratigraphy and Correlation of the Lower Nevada Group (Devonian) North and West of Eureka, Nevada: Geological Society of America Bulletin, V. 81, pp. 127–136.
- McEwen, 2016. Afgan Project Report, McEwen Mining Inc. internal document dated 06 July 2016. 16 pages including appendices.
- McEwen, 2020. McEwen Mining Inc data reported in this report.
- Mineral Resources Development, Inc. (MRDI), 1995, Gold Bar District, Review of Atlas' Exploration Programs: Creation of a Geological-Concept Model, and Recommended Exploration Strategy. Consultant's report for Atlas Gold Corporation dated February, 1995.
- NDEP, 1994, Stability Requirements Heap Leach Pads, guidance document available from the NDEP-BMRR website at <http://ndep.nv.gov/bmrr/file/stabilit.pdf>, Nevada Division of Environmental Protection, Bureau of Mining and Regulation and Reclamation, April 22, 1994.
- Nerco, 1989, Roberts Mountains Project, 1989 Summary, Report by Jack Pritting for Nerco Exploration Company dated December, 1989, 268 p.
- Niles, A. J., 1981, Nevada gold program, Afgan project, 1981 geologic report: Internal report for American Selco Incorporated, April 1981, 11 pages.
- Piteau Associates, 2020, Gold Bar South Open Pit Geotechnical Slope Design Study – McEwen Mining, Technical Memorandum 4003M003\_Final, June 15, 2020.
- Phillips, 2011. Comminution Tests-Gold Pick Project. Consultant's report for U.S. Gold Corporation by Phillips Enterprises, September, 2011.
- Rhys, David, Valli, Franck, Burgess, Rachel, Heitt, Dean, Griesel, Gerry, and Hart, Kerry, 2015, Controls of Fault and Fold Geometry on the Distribution of Gold Mineralization on the Carlin Trend, in Pennell, W. M. and Garside, L. J. eds.: Geological Society of Nevada Symposium Proceedings 2015—New Concepts and Discoveries—Reno, Nevada, May 2015, pp. 333–389.
- SRK Consulting (U.S.) Inc., (2011), reported in SRK Consulting (U.S.) Inc., (2012), Prefeasibility Study Gold Bar Project, Eureka County, Nevada; Prepared for McEwen Mining, Inc., April 17, 2012; effective date November 28, 2011.
- SRK Consulting (U.S.) Inc., (2012), Prefeasibility Study Gold Bar Project, Eureka County, Nevada; Prepared for McEwen Mining, Inc., April 17, 2012, effective date November 28, 2011.
- SRK, 2012a. Prefeasibility Geotechnical Pit Slope Evaluation Gold Bar Project, Eureka County, Nevada. Prepared for McEwen Mining Inc., March 23, 2012.
- SRK Consulting (U.S.) Inc., 2013, Final Waste Rock and Ore Geochemical Characterization Report for the Gold Bar Project, Eureka County, Nevada. Prepared for McEwen Mining Inc. by SRK Consulting, U.S. Inc., December, 2013.

**GOLD BAR PROJECT**  
**FORM 43-101F1 TECHNICAL REPORT – FEASIBILITY STUDY**

---

- SRK, 2015. NI 43-101 Technical Report. Gold Bar Project Feasibility Study, Eureka Nevada; Prepared by SRK Consulting (U.S.) Inc. for McEwen Mining, Inc., December 2, 2015. Effective Date 30 September 2015.
- Suda, R. U., 1997, Summary of the 1996 Afgan-Kobeh reverse circulation drilling: Cominco American Inc. report.
- Telesto, 2008, Final NI 43-101 Technical Report Gold Pick Project (Gold Pick and Gold Ridge North), Eureka County, Nevada. Report prepared by Telesto Nevada for US Gold Corporation, dated November, 2008, 95 p. plus appendices.
- Telesto, 2009, NI-43-101 Technical Report for the Gold Pick Project, Expanded to Include the Cabin Creek and Hunter Resources, Eureka County, Nevada. Report prepared by Telesto Nevada for US Gold Corporation, dated May 5, 2009, 164 p. plus appendices.
- Telesto, 2010. NI 43-101 Preliminary Assessment of US Gold Corporation's Gold Bar Project, Including Gold Pick, Gold Ridge, Cabin Creek and Hunter, Eureka County, Nevada. Report prepared for US Gold Corporation by Telesto Nevada Inc., April 15, 2010, 231 p. plus appendices.
- Tschabrun, 1994, Ore Reserve and Mine Plan Update, Gold Bar Satellite Project: Consultant's report for Atlas Corporation dated August 321, 1994.
- Wright, J. L., 2008a, Afgan Property Gravity Survey GIS Database: Report dated April 24, 2008, prepared for Midway Gold Corporation by Wright Geophysics, 14 p. plus appendix.
- Wright, J. L., 2008b (November 28), Afgan Property Ground Magnetic Survey GIS Database: Report dated November 28, 2008, prepared for Midway Gold Corporation by Wright Geophysics, 14 p. plus appendix.
- Yigit, Ozcan, 2001, Structural Controls and Geochemistry of Carlin-Type Gold Mineralization in The Gold Bar District, Eureka County, Nevada: Colorado School of Mines Ph. D thesis, 213 p.
- Yigit, O., Nelson, E.P., Hitzman, M.W. and Hofstra, A.H., 2003, Structural Controls on Carlin-Type Gold Mineralization in the Gold Bar District, Eureka County, Nevada: Economic Geology, v. 98, no. 6, p. 1173-1188.
- Yigit, O., Hofstra, A. H., Hitzman, M. W. and Nelson, E. P., 2006, Geology and geochemistry of jasperoids from the Gold Bar District, Nevada: Miner Deposita v.41, pp. 527–547.

## **25 RELIANCE ON INFORMATION SUPPLIED BY REGISTRANT**

The QPs' opinion contained herein is based on information provided to the QPs by McEwen throughout the course of the investigations.

The items pertaining to land tenure and claim ownership in Section 25 have not been independently reviewed by the QPs and the QPs did not seek an independent legal opinion of these items.

The QPs used their experience to determine if the information from previous reports was suitable for inclusion in this technical report and adjusted information that required amending. This report includes technical information, which required subsequent calculations to derive subtotals, totals, and weighted averages. Such calculations inherently involve a degree of rounding and consequently introduce a margin of error. Where these occur, the QPs do not consider them to be material.

The QP's take responsibility for the content of this report and believe it is accurate and complete in all material aspects.

**APPENDIX A: CLAIMS LIST FOR GOLD BAR NORTH AND SOUTH**

**GOLD BAR NORTH**

| <b>Claim Name</b> | <b>BLM Nevada Mining Claim Serial Number</b> | <b>Claim Type</b> | <b>Claim Name</b> | <b>BLM Nevada Mining Claim Serial Number</b> | <b>Claim Type</b> |
|-------------------|--|-------------------|-------------------|--|-------------------|
| Ben 1             | 867958                                       | LODE              | Ben 5             | 867962                                       | LODE              |
| Ben 10            | 867967                                       | LODE              | Ben 50            | 889051                                       | LODE              |
| Ben 11            | 867968                                       | LODE              | Ben 51            | 868008                                       | LODE              |
| Ben 12            | 867969                                       | LODE              | Ben 55            | 878747                                       | LODE              |
| Ben 13            | 867970                                       | LODE              | Ben 56            | 878748                                       | LODE              |
| Ben 14            | 867971                                       | LODE              | Ben 57            | 878749                                       | LODE              |
| Ben 15            | 867972                                       | LODE              | Ben 58            | 878750                                       | LODE              |
| Ben 16            | 867973                                       | LODE              | Ben 59            | 878751                                       | LODE              |
| Ben 17            | 867974                                       | LODE              | Ben 6             | 867963                                       | LODE              |
| Ben 18            | 867975                                       | LODE              | Ben 60            | 878752                                       | LODE              |
| Ben 19            | 867976                                       | LODE              | Ben 61            | 878753                                       | LODE              |
| Ben 2             | 867959                                       | LODE              | Ben 62            | 878754                                       | LODE              |
| Ben 20            | 867977                                       | LODE              | Ben 63            | 878755                                       | LODE              |
| Ben 21            | 867978                                       | LODE              | Ben 64            | 878756                                       | LODE              |
| Ben 22            | 867979                                       | LODE              | Ben 65            | 878757                                       | LODE              |
| Ben 23            | 867980                                       | LODE              | Ben 66            | 878758                                       | LODE              |
| Ben 24            | 867981                                       | LODE              | Ben 67            | 878759                                       | LODE              |
| Ben 25            | 867982                                       | LODE              | Ben 68            | 878760                                       | LODE              |
| Ben 26            | 867983                                       | LODE              | Ben 69            | 878761                                       | LODE              |
| Ben 27            | 867984                                       | LODE              | Ben 7             | 867964                                       | LODE              |
| Ben 28            | 867985                                       | LODE              | Ben 70            | 878762                                       | LODE              |
| Ben 29            | 867986                                       | LODE              | Ben 72            | 878764                                       | LODE              |
| Ben 3             | 867960                                       | LODE              | Ben 78            | 899898                                       | LODE              |
| Ben 30            | 867987                                       | LODE              | Ben 79            | 899899                                       | LODE              |
| Ben 31            | 867988                                       | LODE              | Ben 8             | 867965                                       | LODE              |
| Ben 32            | 867989                                       | LODE              | Ben 80            | 899900                                       | LODE              |
| Ben 33            | 867990                                       | LODE              | Ben 81            | 899901                                       | LODE              |
| Ben 34            | 867991                                       | LODE              | Ben 82            | 899902                                       | LODE              |
| Ben 35            | 889048                                       | LODE              | Ben 83            | 899903                                       | LODE              |
| Ben 36            | 889049                                       | LODE              | Ben 84            | 903225                                       | LODE              |
| Ben 37            | 867994                                       | LODE              | Ben 85            | 899904                                       | LODE              |
| Ben 38            | 867995                                       | LODE              | Ben 86            | 899905                                       | LODE              |
| Ben 4             | 867961                                       | LODE              | Ben 87            | 899906                                       | LODE              |
| Ben 41            | 867998                                       | LODE              | Ben 88            | 899907                                       | LODE              |
| Ben 42            | 867999                                       | LODE              | Ben 89            | 899908                                       | LODE              |
| Ben 43            | 868000                                       | LODE              | Ben 9             | 867966                                       | LODE              |
| Ben 44            | 868001                                       | LODE              | Ben 90            | 899909                                       | LODE              |
| Ben 45            | 868002                                       | LODE              | Ben 91            | 899910                                       | LODE              |
| Ben 46            | 868003                                       | LODE              | Ben 92            | 899911                                       | LODE              |
| Ben 47            | 868004                                       | LODE              | Ben 93            | 899912                                       | LODE              |
| Ben 48            | 868005                                       | LODE              | Ben 94            | 899913                                       | LODE              |
| Ben 49            | 889050                                       | LODE              | Ben 95            | 908313                                       | LODE              |

**GOLD BAR NORTH**

| <b>Claim Name</b> | <b>BLM Nevada Mining Claim Serial Number</b> | <b>Claim Type</b> | <b>Claim Name</b> | <b>BLM Nevada Mining Claim Serial Number</b> | <b>Claim Type</b> |
|-------------------|--|-------------------|-------------------|--|-------------------|
| Ben 96            | 908314                                       | LODE              | OLIVER 22         | 826973                                       | LODE              |
| Ben 97            | 908315                                       | LODE              | OLIVER 25         | 830532                                       | LODE              |
| Ben 98            | 908316                                       | LODE              | OLIVER 26         | 830533                                       | LODE              |
| Ben 99            | 908317                                       | LODE              | OLIVER 28         | 830535                                       | LODE              |
| CC 1              | 842435                                       | LODE              | OLIVER 3          | 826954                                       | LODE              |
| CC 10             | 842444                                       | LODE              | OLIVER 4          | 826955                                       | LODE              |
| CC 2              | 842436                                       | LODE              | OLIVER 5          | 826956                                       | LODE              |
| CC 3              | 842437                                       | LODE              | OLIVER 6          | 826957                                       | LODE              |
| CC 4              | 842438                                       | LODE              | OLIVER 7          | 826958                                       | LODE              |
| CC 5              | 842439                                       | LODE              | OLIVER 8          | 826959                                       | LODE              |
| CC 6              | 842440                                       | LODE              | OLIVER 9          | 826960                                       | LODE              |
| CC 7              | 842441                                       | LODE              | Pik 1             | 902252                                       | LODE              |
| CC 8              | 842442                                       | LODE              | Pik 11A           | 920892                                       | LODE              |
| CC 9              | 842443                                       | LODE              | Pik 15            | 902264                                       | LODE              |
| DS 7              | 880446                                       | LODE              | Pik 16            | 902265                                       | LODE              |
| DS 8              | 878988                                       | LODE              | Pik 17            | 902266                                       | LODE              |
| GBW 96            | 969099                                       | LODE              | Pik 18            | 902267                                       | LODE              |
| Gin 2             | 826899                                       | LODE              | Pik 19            | 902268                                       | LODE              |
| Gin 4             | 826901                                       | LODE              | Pik 2             | 902253                                       | LODE              |
| Gin 6             | 826903                                       | LODE              | Pik 20            | 902269                                       | LODE              |
| HR 1              | 1027612                                      | LODE              | Pik 21            | 902270                                       | LODE              |
| HR 2              | 1027613                                      | LODE              | Pik 22            | 902271                                       | LODE              |
| Hunter 1          | 1003751                                      | LODE              | Pik 23            | 902272                                       | LODE              |
| Hunter 2          | 1003752                                      | LODE              | Pik 24            | 902273                                       | LODE              |
| Hunter 3          | 1003753                                      | LODE              | Pik 25            | 902274                                       | LODE              |
| IAN 48            | 889139                                       | LODE              | Pik 26            | 902275                                       | LODE              |
| IAN 49            | 889140                                       | LODE              | Pik 27            | 902276                                       | LODE              |
| IAN 51            | 889141                                       | LODE              | Pik 28            | 902277                                       | LODE              |
| IAN 52            | 889142                                       | LODE              | Pik 29            | 902278                                       | LODE              |
| OLIVER 1          | 826952                                       | LODE              | Pik 3             | 902254                                       | LODE              |
| OLIVER 10         | 826961                                       | LODE              | Pik 4             | 902255                                       | LODE              |
| OLIVER 11         | 826962                                       | LODE              | Pik 5             | 902256                                       | LODE              |
| OLIVER 12         | 826963                                       | LODE              | Pik 6             | 902257                                       | LODE              |
| OLIVER 13         | 826964                                       | LODE              | Pik 7             | 902258                                       | LODE              |
| OLIVER 14         | 826965                                       | LODE              | Pik 8             | 902259                                       | LODE              |
| OLIVER 15         | 826966                                       | LODE              | Pik 9A            | 920891                                       | LODE              |
| OLIVER 16         | 826967                                       | LODE              | RCN 21            | 1008179                                      | LODE              |
| OLIVER 17         | 826968                                       | LODE              | RCN 22            | 1008180                                      | LODE              |
| OLIVER 18         | 826969                                       | LODE              | RCN 23            | 1008181                                      | LODE              |
| OLIVER 19         | 826970                                       | LODE              | RCN 24            | 1008182                                      | LODE              |
| OLIVER 2          | 826953                                       | LODE              | RCN 25            | 1008183                                      | LODE              |
| OLIVER 20         | 826971                                       | LODE              | RCN 26            | 1008184                                      | LODE              |

**GOLD BAR NORTH**

| <b>Claim Name</b> | <b>BLM Nevada Mining Claim Serial Number</b> | <b>Claim Type</b> | <b>Claim Name</b> | <b>BLM Nevada Mining Claim Serial Number</b> | <b>Claim Type</b> |
|-------------------|--|-------------------|-------------------|--|-------------------|
| RCN 27            | 1008185                                      | LODE              | Sno 42            | 865217                                       | LODE              |
| RCN 28            | 1008186                                      | LODE              | Sno 43            | 865218                                       | LODE              |
| RCN 49            | 1008207                                      | LODE              | Sno 44            | 902467                                       | LODE              |
| RCN 51            | 1008209                                      | LODE              | Sno 45            | 902468                                       | LODE              |
| RCN 53            | 1008211                                      | LODE              | Sno 46            | 902469                                       | LODE              |
| RCN 55            | 1008213                                      | LODE              | Sno 47            | 902470                                       | LODE              |
| Ruth 2            | 1001301                                      | LODE              | Sno 48            | 902471                                       | LODE              |
| Ruth 3            | 1001302                                      | LODE              | Sno 49            | 902472                                       | LODE              |
| Sno 1             | 865176                                       | LODE              | Sno 5             | 865180                                       | LODE              |
| Sno 10            | 865185                                       | LODE              | Sno 50            | 902473                                       | LODE              |
| Sno 11            | 865186                                       | LODE              | Sno 51            | 902474                                       | LODE              |
| Sno 12            | 865187                                       | LODE              | Sno 52            | 902475                                       | LODE              |
| Sno 13            | 865188                                       | LODE              | Sno 53            | 902476                                       | LODE              |
| Sno 14            | 865189                                       | LODE              | Sno 54            | 902477                                       | LODE              |
| Sno 15            | 865190                                       | LODE              | Sno 55            | 902478                                       | LODE              |
| Sno 16            | 865191                                       | LODE              | Sno 56            | 902479                                       | LODE              |
| Sno 17            | 865192                                       | LODE              | Sno 57            | 902480                                       | LODE              |
| Sno 18            | 865193                                       | LODE              | Sno 58            | 902481                                       | LODE              |
| Sno 2             | 865177                                       | LODE              | Sno 59            | 902482                                       | LODE              |
| Sno 20            | 865195                                       | LODE              | Sno 6             | 865181                                       | LODE              |
| Sno 21            | 865196                                       | LODE              | Sno 60            | 902483                                       | LODE              |
| Sno 22            | 865197                                       | LODE              | Sno 61 R          | 902484                                       | LODE              |
| Sno 23            | 865198                                       | LODE              | Sno 62            | 902485                                       | LODE              |
| Sno 24            | 865199                                       | LODE              | Sno 7             | 865182                                       | LODE              |
| Sno 25            | 865200                                       | LODE              | Sno 8             | 865183                                       | LODE              |
| Sno 26            | 865201                                       | LODE              | Sno 9             | 865184                                       | LODE              |
| Sno 27            | 865202                                       | LODE              | Soren 1           | 896376                                       | LODE              |
| Sno 28            | 865203                                       | LODE              | Soren 10          | 896385                                       | LODE              |
| Sno 3             | 865178                                       | LODE              | Soren 11          | 896386                                       | LODE              |
| Sno 30            | 865205                                       | LODE              | Soren 12          | 896387                                       | LODE              |
| Sno 31            | 865206                                       | LODE              | Soren 13          | 896388                                       | LODE              |
| Sno 32            | 865207                                       | LODE              | Soren 14          | 896389                                       | LODE              |
| Sno 33            | 865208                                       | LODE              | Soren 15          | 896390                                       | LODE              |
| Sno 34            | 865209                                       | LODE              | Soren 16          | 896391                                       | LODE              |
| Sno 35            | 865210                                       | LODE              | Soren 17          | 896392                                       | LODE              |
| Sno 36            | 865211                                       | LODE              | Soren 18          | 896393                                       | LODE              |
| Sno 37            | 865212                                       | LODE              | Soren 2           | 896378                                       | LODE              |
| Sno 38            | 865213                                       | LODE              | Soren 21          | 896396                                       | LODE              |
| Sno 39            | 865214                                       | LODE              | Soren 22          | 896397                                       | LODE              |
| Sno 4             | 865179                                       | LODE              | Soren 23          | 896398                                       | LODE              |
| Sno 40            | 865215                                       | LODE              | Soren 24          | 896399                                       | LODE              |
| Sno 41            | 865216                                       | LODE              | Soren 25          | 896400                                       | LODE              |

**GOLD BAR NORTH**

| <b>Claim Name</b> | <b>BLM Nevada Mining Claim Serial Number</b> | <b>Claim Type</b> | <b>Claim Name</b> | <b>BLM Nevada Mining Claim Serial Number</b> | <b>Claim Type</b> |
|-------------------|--|-------------------|-------------------|--|-------------------|
| Soren 26          | 896401                                       | LODE              | Toast 11          | 899916                                       | LODE              |
| Soren 27          | 896402                                       | LODE              | Toast 12          | 899917                                       | LODE              |
| Soren 28          | 896403                                       | LODE              | Toast 13          | 899918                                       | LODE              |
| Soren 29          | 896404                                       | LODE              | Toast 14          | 899919                                       | LODE              |
| Soren 3           | 896378                                       | LODE              | Toast 15          | 899920                                       | LODE              |
| Soren 30          | 896405                                       | LODE              | Toast 16          | 899921                                       | LODE              |
| Soren 31          | 896406                                       | LODE              | Toast 17          | 899922                                       | LODE              |
| Soren 32          | 896407                                       | LODE              | Toast 18          | 899923                                       | LODE              |
| Soren 33          | 896408                                       | LODE              | Toast 19          | 899924                                       | LODE              |
| Soren 34          | 896409                                       | LODE              | Toast 9           | 826951                                       | LODE              |
| Soren 35          | 896410                                       | LODE              | GPN 1             | 1132378                                      | LODE              |
| Soren 36          | 896411                                       | LODE              | GPN 2             | 1132379                                      | LODE              |
| Soren 39          | 896414                                       | LODE              | GPN 3             | 1132380                                      | LODE              |
| Soren 4           | 896379                                       | LODE              | GPN 4             | 1132381                                      | LODE              |
| Soren 40          | 896415                                       | LODE              | WI 111            |  | PATENT            |
| Soren 41          | 896416                                       | LODE              | WI 112            |  | PATENT            |
| Soren 42          | 896417                                       | LODE              | WI 113            |  | PATENT            |
| Soren 43          | 896418                                       | LODE              | WI 114            |  | PATENT            |
| Soren 44          | 896419                                       | LODE              | WI 115            |  | PATENT            |
| Soren 45          | 896420                                       | LODE              | WI 162            |  | PATENT            |
| Soren 46          | 896421                                       | LODE              | WI 164            |  | PATENT            |
| Soren 47          | 896422                                       | LODE              | WI 166            |  | PATENT            |
| Soren 48          | 896423                                       | LODE              | WI 64             |  | PATENT            |
| Soren 49          | 896424                                       | LODE              | WI 66             |  | PATENT            |
| Soren 5           | 896380                                       | LODE              |                   |  |                   |
| Soren 50          | 896425                                       | LODE              |                   |  |                   |
| Soren 51          | 896426                                       | LODE              |                   |  |                   |
| Soren 52          | 896427                                       | LODE              |                   |  |                   |
| Soren 53          | 896428                                       | LODE              |                   |  |                   |
| Soren 54          | 896429                                       | LODE              |                   |  |                   |
| Soren 6           | 896381                                       | LODE              |                   |  |                   |
| Soren 7           | 896382                                       | LODE              |                   |  |                   |
| Soren 8           | 896383                                       | LODE              |                   |  |                   |
| Soren 9           | 896384                                       | LODE              |                   |  |                   |
| SW 31             | 857738                                       | LODE              |                   |  |                   |
| SW 32             | 857739                                       | LODE              |                   |  |                   |
| SW 33             | 857740                                       | LODE              |                   |  |                   |
| SW 34             | 857741                                       | LODE              |                   |  |                   |
| SW 35             | 857742                                       | LODE              |                   |  |                   |
| SW 36             | 857743                                       | LODE              |                   |  |                   |
| SW 37             | 857744                                       | LODE              |                   |  |                   |
| SW 39             | 857746                                       | LODE              |                   |  |                   |



GOLD BAR SOUTH

| Claim Name      | BLM Nevada Mining Claim Serial Number | Claim Type | Claim Name      | BLM Nevada Mining Claim Serial Number | Claim Type |
|-----------------|---------------------------------------|------------|-----------------|---------------------------------------|------------|
| AE 1            | 1179083                               | LODE       | Afgan Ext. #121 | 592436                                | LODE       |
| AE 15           | 1179097                               | LODE       | Afgan Ext. #122 | 622127                                | LODE       |
| AE 16           | 1179098                               | LODE       | Afgan Ext. #123 | 622128                                | LODE       |
| AE 17           | 1179099                               | LODE       | Afgan Ext. #124 | 622129                                | LODE       |
| AE 19           | 1179101                               | LODE       | Afgan Ext. #125 | 622130                                | LODE       |
| AE 3            | 1179085                               | LODE       | Afgan Ext. #126 | 622131                                | LODE       |
| AE 31           | 1179113                               | LODE       | Afgan Ext. #127 | 638155                                | LODE       |
| AE 4            | 1179086                               | LODE       | Afgan Ext. #128 | 638156                                | LODE       |
| AE 58           | 1182951                               | LODE       | Afgan Ext. #129 | 638157                                | LODE       |
| Afgan #10       | 169158                                | LODE       | Afgan Ext. #130 | 638158                                | LODE       |
| Afgan #11       | 169159                                | LODE       | Afgan Ext. #131 | 638159                                | LODE       |
| Afgan #12       | 169160                                | LODE       | Afgan Ext. #132 | 638160                                | LODE       |
| Afgan #13       | 289576                                | LODE       | Afgan Ext. #133 | 638161                                | LODE       |
| Afgan #14       | 289577                                | LODE       | Afgan Ext. #134 | 638162                                | LODE       |
| Afgan #15       | 289578                                | LODE       | Afgan Ext. #2   | 592425                                | LODE       |
| Afgan #16       | 289579                                | LODE       | Afgan Ext. #2A  | 674809                                | LODE       |
| Afgan #17       | 289580                                | LODE       | Afgan Ext. #30  | 674810                                | LODE       |
| Afgan #18       | 289581                                | LODE       | Afgan Ext. #31  | 674811                                | LODE       |
| Afgan #19       | 289582                                | LODE       | Afgan Ext. #33  | 674813                                | LODE       |
| Afgan #20       | 289583                                | LODE       | Afgan Ext. #34  | 674814                                | LODE       |
| Afgan #21       | 289584                                | LODE       | Afgan Ext. #35  | 674815                                | LODE       |
| Afgan #22       | 289585                                | LODE       | Afgan Ext. #36  | 674816                                | LODE       |
| Afgan #23       | 289586                                | LODE       | Afgan Ext. #37  | 674817                                | LODE       |
| Afgan #24       | 289587                                | LODE       | Afgan Ext. #38  | 674818                                | LODE       |
| Afgan #25       | 289588                                | LODE       | Afgan Ext. #39  | 674819                                | LODE       |
| Afgan #26       | 289589                                | LODE       | Afgan Ext. #68  | 602418                                | LODE       |
| Afgan #3        | 169151                                | LODE       | Afgan Ext. #72  | 592428                                | LODE       |
| Afgan #4        | 169152                                | LODE       | Afgan Ext. #73  | 592429                                | LODE       |
| Afgan #5        | 169153                                | LODE       | AG 1            | 1121158                               | LODE       |
| Afgan #6        | 169154                                | LODE       | AG 10           | 1121167                               | LODE       |
| Afgan #69       | 289590                                | LODE       | AG 11           | 1121168                               | LODE       |
| Afgan #7        | 169155                                | LODE       | AG 12           | 1121169                               | LODE       |
| Afgan #70       | 289591                                | LODE       | AG 13           | 1121170                               | LODE       |
| Afgan #71       | 289592                                | LODE       | AG 2            | 1121159                               | LODE       |
| Afgan #8        | 169156                                | LODE       | AG 3            | 1121160                               | LODE       |
| Afgan #9        | 169157                                | LODE       | AG 4            | 1121161                               | LODE       |
| Afgan Ext. #1   | 592424                                | LODE       | AG 5            | 1121162                               | LODE       |
| Afgan Ext. #101 | 592430                                | LODE       | AG 6            | 1121163                               | LODE       |
| Afgan Ext. #102 | 592431                                | LODE       | AG 7            | 1121164                               | LODE       |
| Afgan Ext. #103 | 592432                                | LODE       | AG 8            | 1121165                               | LODE       |
| Afgan Ext. #104 | 592433                                | LODE       | AG 9            | 1121166                               | LODE       |
| Afgan Ext. #105 | 592434                                | LODE       | BV 195          | 1121667                               | LODE       |
| Afgan Ext. #120 | 592435                                | LODE       | BV 197          | 1121669                               | LODE       |

## GOLD BAR SOUTH

| Claim Name | BLM Nevada Mining Claim Serial Number | Claim Type | Claim Name  | BLM Nevada Mining Claim Serial Number | Claim Type |
|------------|---------------------------------------|------------|-------------|---------------------------------------|------------|
| BV 199     | 1121671                               | LODE       | HUNTED 24   | 826275                                | LODE       |
| BV 201     | 1121673                               | LODE       | HUNTED 25   | 826276                                | LODE       |
| BV 225     | 1121697                               | LODE       | HUNTED 26   | 826277                                | LODE       |
| BV 227     | 1121699                               | LODE       | HUNTED 27   | 826278                                | LODE       |
| BV 229     | 1121701                               | LODE       | HUNTED 28   | 826279                                | LODE       |
| BV 230     | 1121702                               | LODE       | HUNTED 29   | 826280                                | LODE       |
| BV 239     | 1121711                               | LODE       | HUNTED 3    | 826258                                | LODE       |
| BV 249     | 1121721                               | LODE       | HUNTED 30   | 826281                                | LODE       |
| BV 190     | 1121662                               | LODE       | HUNTED 31   | 826282                                | LODE       |
| HNT 1      | 824929                                | LODE       | HUNTED 32   | 826283                                | LODE       |
| HNT 2      | 824930                                | LODE       | HUNTED 33   | 826284                                | LODE       |
| HUN 10     | 1177105                               | LODE       | HUNTED 34   | 826285                                | LODE       |
| HUN 15     | 1177110                               | LODE       | HUNTED 35   | 826286                                | LODE       |
| HUN 16     | 1177111                               | LODE       | HUNTED 36   | 826287                                | LODE       |
| HUN 23     | 1177118                               | LODE       | HUNTED 4    | 826259                                | LODE       |
| HUN 24     | 1177119                               | LODE       | HUNTED 49   | 826298                                | LODE       |
| HUN 25     | 1177120                               | LODE       | HUNTED 5    | 826260                                | LODE       |
| HUN 26     | 1177121                               | LODE       | HUNTED 50   | 826299                                | LODE       |
| HUN 27     | 1177122                               | LODE       | HUNTED 51   | 826300                                | LODE       |
| HUN 28     | 1177123                               | LODE       | HUNTED 53   | 826301                                | LODE       |
| HUN 29     | 1177124                               | LODE       | HUNTED 6    | 826261                                | LODE       |
| HUN 3      | 1177098                               | LODE       | Kobeh #2130 | 637538                                | LODE       |
| HUN 30     | 1177125                               | LODE       | Kobeh #2131 | 637539                                | LODE       |
| HUN 31     | 1177126                               | LODE       | Kobeh #2132 | 637540                                | LODE       |
| HUN 32     | 1177127                               | LODE       | Kobeh #2230 | 637554                                | LODE       |
| HUN 33     | 1177128                               | LODE       | Kobeh #2231 | 637555                                | LODE       |
| HUN 4      | 1177099                               | LODE       | Kobeh #2232 | 637556                                | LODE       |
| HUN 41     | 1177136                               | LODE       | Nickel 10   | 674822                                | LODE       |
| HUN 42     | 1177137                               | LODE       | Nickel 11   | 674823                                | LODE       |
| HUN 43     | 1177138                               | LODE       | Nickel 12   | 674824                                | LODE       |
| HUN 5      | 1177100                               | LODE       | Nickel 13   | 674825                                | LODE       |
| HUN 6      | 1177101                               | LODE       | Nickel 8    | 674820                                | LODE       |
| HUN 7      | 1177102                               | LODE       | Nickel 9    | 674821                                | LODE       |
| HUN 8      | 1177103                               | LODE       | Predator 1  | 698064                                | LODE       |
| HUN 9      | 1177104                               | LODE       | Predator 2  | 698065                                | LODE       |
| HUNTED 1   | 826256                                | LODE       | Predator 3  | 698066                                | LODE       |
| HUNTED 17  | 826269                                | LODE       | Predator 4  | 698067                                | LODE       |
| HUNTED 18  | 826270                                | LODE       | WW 25       | 948019                                | LODE       |
| HUNTED 19  | 826271                                | LODE       | WW 26       | 948020                                | LODE       |
| HUNTED 2   | 826257                                | LODE       | WW 33       | 948027                                | LODE       |
| HUNTED 20  | 826272                                | LODE       | WW 50       | 948035                                | LODE       |
| HUNTED 21  | 826273                                | LODE       | WW 51       | 948036                                | LODE       |
| HUNTED 23  | 826274                                | LODE       | WW 52       | 948037                                | LODE       |

GOLD BAR SOUTH

| <b>Claim Name</b> | <b>BLM Nevada<br/>Mining Claim<br/>Serial Number</b> | <b>Claim Type</b> |
|-------------------|--|-------------------|
| WW 53             | 948038   | LODE              |
| WW 54             | 948039   | LODE              |
| WW 55             | 948040   | LODE              |