



NI 43-101 Technical Report

Feasibility Study for the Windfall Project

Eeyou Istchee James Bay, Québec, Canada

Prepared for:
Osisko Mining Inc.



Effective Date: November 25, 2022

Signature Date: January 10, 2023

Prepared by the following Qualified Persons:

- Patrick Andrieux, P.Eng. A2GC
- Mathieu Bélisle, P.Eng. BBA Inc.
- Colin Hardie, P.Eng. BBA Inc.
- Patrick Langlais, P.Eng. Entech Mining Ltd.
- Mélissa Tremblay, P.Eng. GMC Consultants Inc.
- Pierre-Luc Richard, P.Geo. PLR Resources Inc.
- Yves Boulianne, P.Eng. Golder Associates Ltd.
- Ken De Vos, P.Geo. Golder Associates Ltd.
- Aytaç Göksu, P.Eng. Golder Associates Ltd.
- Frédéric Choquet, P.Eng. WSP Canada Inc.
- Andréanne Hamel, P.Eng. WSP Canada Inc.
- Isabelle Larouche, P.Eng. WSP Canada Inc.
- Éric Poirier, P.Eng. WSP Canada Inc.





Osisko Mining Inc.

NI 43-101 – Technical Report

Feasibility Study for the Windfall Project



IMPORTANT NOTICE

This report was prepared as a National Instrument 43-101 *Standards of Disclosure for Mineral Projects* Technical Report for Osisko Mining Inc. ("Osisko") by BBA Inc. ("BBA"), PLR Resources Inc. ("PLR"), WSP Canada Inc. ("WSP"), Golder Associates Ltd. ("Golder"), Entech Mining Ltd. ("Entech"), Andrieux & Associates Geomechanics Consulting, L.P. ("A2GC"), and GCM Consultants Inc. ("GCM") known as the "Report Authors". The quality of information, conclusions, and estimates contained herein is consistent with the level of effort involved in the Report Authors' services, based on i) information available at the time of preparation, ii) data supplied by outside sources, and iii) the assumptions, conditions, and qualifications set forth in this report. This report is intended for use by Osisko subject to the terms and conditions of its contract with the Report Authors and relevant securities legislation. The contract allows Osisko to file this report as a Technical Report with Canadian Securities Regulatory Authorities pursuant to National Instrument 43-101. Except for the purposes legislated under provincial securities law, any other use of this report by any third party is at that party's sole risk. The responsibility for this disclosure remains with Osisko. The user of this document should ensure that this is the most recent Technical Report for the property as it is not valid if a new Technical Report has been issued.



DATE AND SIGNATURE PAGE

This report is effective as of the 10th day of January 2023.

"Signed and sealed original on file"

Patrick Andrieux, P.Eng.
A²GC

January 10, 2023

Date

"Signed and sealed original on file"

Mathieu Bélisle, P.Eng.
BBA Inc.

January 10, 2023

Date

"Signed and sealed original on file"

Colin Hardie, P.Eng.
BBA Inc.

January 10, 2023

Date

"Signed and sealed original on file"

Patrick Langlais, P.Eng.
Entech Mining Ltd.

January 10, 2023

Date



"Signed and sealed original on file"

Mélissa Tremblay, P.Eng.
GCM Consultants Inc.

January 10, 2023

Date

"Signed and sealed original on file"

Pierre-Luc Richard, P.Geo.
PLR Resources Inc.

January 10, 2023

Date

"Signed and sealed original on file"

Yves Boulianne, P.Eng.
Golder Associates Ltd.

January 10, 2023

Date

"Signed and sealed original on file"

Ken De Vos, P.Eng.
Golder Associates Ltd.

January 10, 2023

Date



“Signed and sealed original on file”

Aytaç Göksu, P.Eng.
Golder Associates Ltd.

January 10, 2023

Date

“Signed and sealed original on file”

Frédéric Choquet, P.Eng.
WSP Canada Inc.

January 10, 2023

Date

“Signed and sealed original on file”

Andréanne Hamel, P.Eng.
WSP Canada Inc.

January 10, 2023

Date

“Signed and sealed original on file”

Isabelle Larouche, P.Eng.
WSP Canada Inc.

January 10, 2023

Date



"Signed and sealed original on file"

Éric Poirier, P.Eng., PMP
WSP Canada Inc.

January 10, 2023

Date



CERTIFICATE OF QUALIFIED PERSON

Patrick Andrieux, P.Eng.

This certificate applies to the NI 43-101 Technical Report entitled "Feasibility Study for the Windfall Project, Eeyou Istchee James Bay, Québec, Canada" (the "Technical Report"), prepared for Osisko Mining Inc., dated January 10, 2023, with an effective date of November 25, 2022.

I, Patrick Andrieux, P.Eng., as a co-author of the Technical Report, do hereby certify that:

1. I am a Principal Engineer with A2GC, located in Montreal.
2. I am a graduate mining engineer.
3. I am a member in good standing of OIQ and PEO.
4. My relevant experience includes geomechanics, ground control, numerical modelling, mining engineering and geomechanical mine design.
5. I have read the definition of "qualified person" set out in the NI 43-101 – Standards of Disclosure for Mineral Projects ("NI 43-101") and certify that, by reason of my education, affiliation with a professional association, and past relevant work experience, I fulfill the requirements to be a qualified person for the purposes of NI 43-101.
6. I am independent of the issuer applying all the tests in Section 1.5 of NI 43-101.
7. I am author and responsible for the preparation of Section(s) 16.2, 25.5 and 26.2.1.1. I am also co-author and responsible for the relevant portions of Chapters 1, 2, 3, 25, 26 and 27 of the Technical Report.
8. I have visited the Windfall Property that is the subject of the Technical Report, on September 28 and 29, 2022 as part of this current mandate.
9. I have had prior involvement with the Windfall Project that is the subject of the Technical Report as I performed in January 2020 a technical review of the ground conditions in existing underground development.
10. I have read NI 43-101 and the sections of the Technical Report for which I am responsible have been prepared following NI 43-101 rules and regulations.
11. As at the effective date of the Technical Report, to the best of my knowledge, information and belief, the sections of the Technical Report for which I am responsible contain all scientific and technical information that is required to be disclosed to make the portions of the Technical Report for which I am responsible not misleading.

Signed and sealed this 10th day of January, 2023.

Original signed and sealed on file

Patrick Andrieux, P.Eng.
A2GC



990 route de l'Église, Suite 590,
Québec, QC, G1V 3V7
T +1 418.657.2110
F +1 450.464.0901

BBA.CA

CERTIFICATE OF QUALIFIED PERSON

Mathieu Bélisle, P.Eng.

This certificate applies to the NI 43-101 Technical Report entitled "Feasibility Study for the Windfall Project, Eeyou Istchee James Bay, Québec, Canada" (the "Technical Report"), prepared for Osisko Mining Inc., dated January 10, 2023, with an effective date of November 25, 2022.

I, Mathieu Bélisle, P.Eng., as a co-author of the Technical Report, do hereby certify that:

1. I am a Metallurgist with the firm BBA Inc., located at 990 route de l'Église, Suite 590, Québec, QC, G1V 3V7, Canada.
2. I am a graduate of Laval University, with a Bachelor of Engineering in Metallurgy and Materials in 2002.
3. I am a member in good standing of the Ordre des Ingénieurs du Québec (OIQ #128549), Professional Engineers of Ontario (PEO #10210546), and Professional Engineers and Geoscientists of British-Columbia (EGBC #49319).
4. My relevant experience includes 20 years of experience working for mining operations and engineering consultants. I have been involved in numerous projects requiring detailed engineering design and produced several studies for the mining industry.
5. I have read the definition of "Qualified Person" set out in National Instrument 43-101 – Standards of Disclosure for Mineral Projects ("NI 43-101") and certify that, by reason of my education, affiliation with a professional association (as defined in NI 43-101), and past relevant work experience, I fulfill the requirements to be a Qualified Person for the purposes of NI 43-101.
6. I am independent of the issuer applying all the tests in Section 1.5 of NI 43-101.
7. I am co-author and responsible for the preparation of Chapter 13 (except Section 13.4, 17 (except Sections 17.4 and 17.5), Sections 21.1.3.1.7 (except Area 665) and 21.2.4.1. I am also co-author for the relevant portions of Chapters 1, 2, 3, 24, 25, 26 and 27 of the Technical Report.
8. I have not visited the Windfall Property that is the subject of the Technical Report, as it was not required for the purpose of this mandate.
9. I have been involved with the Property that is the subject of the Technical Report, having participated as a QP on the MRE Update Technical Report for the Windfall Project in February and September 2022.
10. I have read NI 43-101 and the sections of the Technical Report for which I am responsible have been prepared following NI 43-101 rules and guidelines.
11. As at the effective date of the Technical Report, to the best of my knowledge, information and belief, the sections of the Technical Report for which I am responsible contain all scientific and technical information that is required to be disclosed to make the portions of the Technical Report for which I am responsible not misleading.

Signed and sealed this 10th day of January, 2023.

Original signed and sealed on file

Mathieu Bélisle, P.Eng.
BBA Inc.



2020 Robert-Bourassa Blvd., Suite 300
Montréal, QC H3A 2A5
T +1 514.866.2111
F +1 514.866.2116
BBA.CA

CERTIFICATE OF QUALIFIED PERSON

Colin Hardie, P.Eng.

This certificate applies to the NI 43-101 Technical Report entitled "Feasibility Study for the Windfall Project, Eeyou Istchee James Bay, Québec, Canada" (the "Technical Report"), prepared for Osisko Mining Inc., dated January 10, 2023, with an effective date of November 25, 2022.

I, Colin Hardie, P.Eng., as a co-author of the Technical Report, do hereby certify that:

1. I am a senior consultant within the Mining and Metals Business Line with the firm BBA Inc., located at 2020 Robert-Bourassa Blvd., Suite 300, Montréal, Québec, H3A 2A5, Canada.
2. I graduated from the University of Toronto, Ontario Canada, in 1996 with a BAsC in Geological and Mineral Engineering. In 1999, I graduated from McGill University of Montréal, Québec Canada, with an M. Eng. in Metallurgical Engineering and in 2008 obtained a Master of Business Administration (MBA) degree from the University of Montréal (HEC), Québec Canada.
3. I am a member in good standing of the Professional Engineers of Ontario (PEO No: 90512500) since August 2000. I am also a member of the Canadian Institute of Mining, Metallurgy, and Petroleum (Member No. 140556).
4. I have been employed in mining operations, consulting engineering and applied metallurgical research for over 20 years. My relevant project experience includes metallurgical testwork analysis, flowsheet development, cost estimation and financial modeling. Since joining BBA in 2008, I have worked as a senior process engineer and/or lead study integrator for numerous North American iron ore, precious metal, industrial mineral, and base metal projects.
5. I have read the definition of "Qualified Person" set out in National Instrument 43-101 – Standards of Disclosure for Mineral Projects ("NI 43-101") and certify that, by reason of my education, affiliation with a professional association (as defined in NI 43-101), and past relevant work experience, I fulfill the requirements to be a Qualified Person for the purposes of NI 43-101.
6. I am independent of the issuer applying all the tests in Section 1.5 of NI 43-101.
7. I am co-author and responsible for Chapters 1, 2, 3, 4, 5 (except Section 5.3), 19, 22, 24, 25, 26 and 27, and Sections 18.6, 18.18 (except Section 18.18.6), 18.20 and 18.21 and Sections 21.1 (except Sections 21.1.3.1.3, 21.1.3.1.4, 21.1.3.1.6 to 21.1.3.1.8 and 21.1.4.1 to 21.1.4.5), 21.2.1, 21.2.2, 21.2.6 and 21.3, and co-author of Section 21.2.5 of the Technical Report.
8. I have visited the Windfall property that is the subject of the Technical Report on January 28 and 29, 2021.
9. I have had prior involvement with the property that is the subject of the Technical Report, having co-authored previous NI 43-101 reports as a QP for the Windfall Project in 2017 and 2021.
10. I have read NI 43-101 and the sections of the Technical Report for which I am responsible have been prepared following NI 43-101 rules and guidelines.
11. As at the effective date of the Technical Report, to the best of my knowledge, information and belief, the sections of the Technical Report for which I am responsible contain all scientific and technical information that is required to be disclosed to make the portions of the Technical Report for which I am responsible not misleading.

Signed and sealed this 10th day of January, 2023.

"Original signed and sealed on file"

Colin Hardie, P.Eng.
BBA Inc.

CERTIFICATE OF QUALIFIED PERSON

Patrick Langlais, P.Eng.

This certificate applies to the NI 43-101 Technical Report entitled "Feasibility Study for the Windfall Project, Eeyou Istchee James Bay, Québec, Canada" (the "Technical Report"), prepared for Osisko Mining Inc., dated January 10, 2023, with an effective date of November 25, 2022.

I, Patrick Langlais, P.Eng., as a co-author of the Technical Report, do hereby certify that:

1. I am a Mining Engineer with the firm Entech Mining Ltd. located at 100 King St W, Suite 5600, Toronto, Ontario, Canada.
2. I graduated from Queen's University, in 2009 with a Bachelor of Applied Science, Mining Engineering.
3. I am a member in good standing of the Order of Engineers of Québec (OIQ No. 6021556) and Professional Engineers Ontario (PEO No. 100186072).
4. My relevant experience includes ten years of operational experience, composed of eight years in Technical Services and two years in Operations, in addition to three years as a mining engineering consultant. My various roles included mine design, short term planning, ventilation, ground control, project and contract management, long term planning and Technical Services management.
5. I have read the definition of "qualified person" set out in the NI 43-101 – Standards of Disclosure for Mineral Projects ("NI 43-101") and certify that, by reason of my education, affiliation with a professional association, and past relevant work experience, I fulfill the requirements to be a qualified person for the purposes of NI 43-101.
6. I am independent of the issuer applying all the tests in Section 1.5 of NI 43-101.
7. I am author and responsible for Chapters 15 and 16 (except for Sections 16.2 and 16.3) and for Sections 21.1.3.4, 21.1.4.1 and 21.2.3. I am also co-author for the relevant portions of Chapters 1, 2, 25, and 26 of the Technical Report.
8. I have visited the Windfall Lake Project site that is the subject of the Technical Report most recently in February and April 2022, in addition to multiple visits in the previous two years.
9. I have had prior involvement with the property that is the subject of the Technical Report. I have contributed to conceptual mine designs, trade-offs, scheduling options and general site support since September 2020. I have also contributed to the NI 43-101 Technical Report for the Preliminary Economic Assessment of the Windfall Project issued on April 26, 2021.
10. I have read NI 43-101 and the sections of the Technical Report for which I am responsible have been prepared following NI 43-101 rules and guidelines.
11. As of the effective date of the Technical Report, to the best of my knowledge, information and belief, the sections of the Technical Report for which I am responsible contain all scientific and technical information that is required to be disclosed to make the portions of the Technical Report for which I am responsible not misleading.

Signed and sealed this 10th day of January, 2023.

"Signed and sealed original on file"

Patrick Langlais, P.Eng.
Entech Mining Ltd.

CERTIFICATE OF QUALIFIED PERSON

Mélissa Tremblay, P.Eng/M.Eng.

This certificate applies to the NI 43-101 Technical Report entitled *Feasibility Study for the Windfall Project, Eeyou Istchee James Bay, Québec, Canada (the Technical Report)*, prepared for Osisko Mining Inc., dated January 10, 2023, with an effective date of November 25, 2022.

I, Mélissa Tremblay, P.Eng., as a co-author of the Technical Report, do hereby certify that:

1. I am a water treatment Engineer and Chief of the water treatment team with GCM Consultants Inc., located at 9496 Blvd. du Golf, Anjou, Quebec, Canada.
2. I am a graduate of Université de Sherbrooke, Sherbrooke with a Bachelor of engineering in Biotechnological engineering in 2010 and a Masters in Civil Engineering specializing in water treatment.
3. I am a member in good standing of the *Ordre des Ingénieurs du Québec* (OIQ Member No. 5020235).
4. My relevant experience includes more than 4 years of operational experience on a mine site, 2 years of technical support in water treatment operation in various industries, including mining, and 2 years as a water treatment consultant in the mining industry. I have been active in the water treatment field since 2010, contributing to research and working to support water treatment operations.
5. I have read the definition of "qualified person" set out in the *NI 43-101 – Standards of Disclosure for Mineral Projects (NI 43-101)* and certify that, by reason of my education, affiliation with a professional association, and past relevant work experience, I fulfill the requirements to be a qualified person for the purposes of NI 43-101.
6. I am independent of the issuer applying all the tests in Section 1.5 of NI 43-101.
7. I am the author and am responsible for the preparation of Section(s) 18.23.3 and 21.2.5.1. I am also co-author of section 21.1.3.1.8 and 21.2.5 and responsible for the relevant portions of Chapters 1, 2, 3, 25, 26, and 27 of the Technical Report.
8. I visited the Windfall Property that is the subject of the Technical Report, on September 23, 2021, as part of this current mandate.
9. I have had prior involvement with the Windfall Project that is the subject of the Technical Report as I have also contributed to the NI 43-101 Technical Report for the Preliminary Economic Assessment of the Windfall Project issued on April 26, 2022, and I am involved in the bulk sample ammonia water treatment plant design.
10. I have read NI 43-101 and the sections of the Technical Report for which I am responsible have been prepared following NI 43-101 rules and regulations.
11. As at the effective date of the Technical Report, to the best of my knowledge, information and belief, the sections of the Technical Report for which I am responsible contain all scientific and technical information that is required to be disclosed to make the portions of the Technical Report for which I am responsible not misleading.

Signed and sealed this 10th day of January, 2023.

Original signed and sealed on file

Mélissa Tremblay, P.Eng/M.Eng.
GCM Consultants



2000 McGill College Avenue, 6th Floor
Montreal, Quebec H3A 3H3
T: 1-819-527-7118
plr-resources.com

CERTIFICATE OF QUALIFIED PERSON

Pierre-Luc Richard, P.Geo., M.Sc.

This certificate applies to the NI 43-101 Technical Report entitled "Feasibility Study for the Windfall Project, Eeyou Istchee James Bay, Québec, Canada" (the "Technical Report"), prepared for Osisko Mining Inc., dated January 10, 2023, with an effective date of November 25, 2022.

I, Pierre-Luc Richard, P.Geo., M.Sc., as a co-author of the Technical Report, do hereby certify that:

1. I am Geologist and President of PLR Resources Inc., located at 2000 McGill College Avenue, 6th Floor, Montréal, Québec, Canada, H3A 3H3.
2. I am a graduate of Université du Québec à Montréal in Resource Geology in 2004. I also obtained a M.Sc. from Université du Québec à Chicoutimi in Earth Sciences in 2012.
3. I am a member in good standing of the Ordre des Géologues du Québec (OGQ Member No. 1119), the Association of Professional Geoscientists of Ontario (APGO Member No. 1714), and the Northwest Territories Association of Professional Engineers and Geoscientists (NAPEG Member No. L2465).
4. I have worked in the mining industry for more than 20 years. My exploration expertise has been acquired with Richmond Mines Inc., the Ministry of Natural Resources of Québec (Geology Branch), and numerous companies through my career as a consultant. My mining expertise was acquired at the Beaufor mine and several other producers through my career. I managed numerous technical reports, mineral resource estimates and audits as a consultant for InnovExplo from February 2007 to March 2018 and as a consultant for BBA since.
5. I have read the definition of "Qualified Person" set out in National Instrument 43-101 – Standards of Disclosure for Mineral Projects ("NI 43-101") and certify that, by reason of my education, affiliation with a professional association (as defined in NI 43-101), and past relevant work experience, I fulfill the requirements to be a Qualified Person for the purposes of NI 43-101.
6. I am independent of the issuer applying all the tests in Section 1.5 of NI 43-101.
7. I am author and responsible for the preparation of Chapters 6 to 12, 14 and 23 of the Technical Report. I am also co-author for the relevant portions of Chapters 1, 2, 3, 24, 25, 26 and 27 of the Technical Report
8. I visited the Windfall Project that is the subject of this Technical Report on January 28 and 29, 2021, on January 22 and 23, 2022, as well as on July 22 and 23, 2022 as part of MRE Update and this current mandate. I also visited the property on previous occasions in 2017.
9. I have been involved with the Property that is the subject of the Technical Report in 2017 as a consultant. I also have been an independent QP on multiple Technical Report on the Property.
10. I have read NI 43-101 and the sections of the Technical Report for which I am responsible have been prepared following NI 43-101 rules and guidelines.
11. As at the effective date of the Technical Report, to the best of my knowledge, information and belief, the sections of the Technical Report for which I am responsible contain all scientific and technical information that is required to be disclosed to make the portions of the Technical Report for which I am responsible not misleading.

Signed and sealed this 10th day of January, 2023.

"Signed and sealed original on file"

Pierre-Luc Richard, P.Geo., M.Sc.
PLR Resources Inc.

CERTIFICATE OF QUALIFIED PERSON Yves Boulianne

I, Yves Boulianne, state that:

(a) I am a Senior Geotechnical Engineer and Waste Management Specialist at:

Golder Associés Ltée
7250, rue du Mile End, 3rd floor
Montreal, Quebec, Canada H2R 3A4

(b) This certificate applies to the technical report titled “Feasibility Study for the Windfall Project, Eeyou Istchee James Bay, Québec, Canada” with an effective date of: November 25, 2022 (the “Technical Report”).

(c) I am a “qualified person” for the purposes of National Instrument 43-101 (“NI 43-101”). My qualifications as a qualified person are as follows. I am a graduate of the Université du Québec à Chicoutimi, Chicoutimi, Canada with a B.Sc. in Geological Engineering in 1999. My relevant experience after graduation and over 23 years of experience related to the mining industry for the purpose of the Technical Report includes mine waste and tailings facility designs, construction, and project management for conceptual, pre-feasibility, feasibility and detailed designs for tailings deposition and dams for surface waste facilities, including dewatered, thickened, and slurry type tailings. For various projects, I’ve been responsible for providing dam safety inspections, engineer of record services, due diligence and peer reviews, and operational support. I have experience linking engineering design, operation, and environmental facets of projects, especially in Québec and the Canadian arctic. I also provide civil geotechnical support for mines in the areas of haul roads, access roads, and building foundations design.

(d) My most recent personal inspection of each property described in the Technical Report occurred on October 15, 2021, as well as on July 29, 2022 as part of this current mandate and was for a duration of two days.

(e) I am responsible for Item(s) chapter 18.22 and 20.2.4 and co-authors of 1, 2, 18.4, 21.1.3.1.8, 21.1.4, 25, 26 and 27 of the Technical Report.

(f) I am independent of the issuer as described in section 1.5 of NI 43-101.

(g) I have not had prior involvement with the property that is the subject of the Technical Report.

(h) I have read NI 43-101 and the part of the Technical Report for which I am responsible has been prepared in compliance with NI 43-101; and

(i) At the effective date of the Technical Report, to the best of my knowledge, information, and belief, the parts of the Technical Report for which I am responsible, contain(s) all scientific and technical information that is required to be disclosed to make the Technical Report not misleading.

Dated at Montreal, Quebec, Canada this 10 of January, 2023.

Signed and sealed original on file

Yves Boulianne, P.Eng., OIQ#127801

CERTIFICATE OF QUALIFIED PERSON Ken De Vos

I, Ken De Vos, state that:

(a) I am a Geochemist at:

Golder Associates Ltd.
6925 Century Avenue, 2nd floor
Mississauga (Ontario) Canada L5N 7K2

(b) This certificate applies to the technical report titled “Feasibility Study for the Windfall Project, Eeyou Istchee James Bay, Québec, Canada” with an effective date of: 25 November, 2022 (the “Technical Report”).

(c) I am a “qualified person” for the purposes of National Instrument 43-101 (“NI 43-101”). My qualifications as a qualified person are as follows. I am a graduate of University of Waterloo with a Bachelor's degree in Applied Earth Sciences (Geophysics) (1992) and a Masters degree in Applied Earth Sciences (Hydrogeology and Geochemistry) (1995). I am a member of the Association Professional Geoscientists of Ontario (P.Geol. member #0907); Association of Professional Engineers and Geoscientists of Alberta (P.Geol.; APEGA member #17089); Association of Professional Engineers and Geoscientists of NWT and Nunavut (P.Geol.; NAPEG Registrant #L1349); and Ordre des géologues du Québec – (Licencee #02265). My relevant experience after graduation and over the past 27 years for the purpose of the Technical Report includes evaluation of geochemical conditions related to acid mine drainage and metal leaching, as well as evaluation and prediction of water quality for mining properties throughout Canada and worldwide.

(d) My most recent personal inspection of each property described in the Technical Report occurred on September 28, 2022 and was for a duration of 1 days.

(e) I am responsible for Item(s) Chapter 20.1.1 of the Technical Report.

(f) I am independent of the issuer as described in section 1.5 of NI 43-101.

(g) My prior involvement with the property that is the subject of the Technical Report is as follows: Review and evaluation of geochemical samples, data, and information related to the property.

(h) I have read NI 43-101 and the part of the Technical Report for which I am responsible has been prepared in compliance with NI 43-101; and

(i) At the effective date of the Technical Report, to the best of my knowledge, information, and belief, the parts of the Technical Report for which I am responsible, contain(s) all scientific and technical information that is required to be disclosed to make the Technical Report not misleading.

Dated at Mississauga, Ontario, Canada this 10 of January, 2023.

-signed and sealed original on file –

Ken De Vos, P.Geol., PGO #0907; APEGA #17089; NAPEG #L1349 and OIQ #02265

CERTIFICATE OF QUALIFIED PERSON

Aytaç Göksu, P.Eng.

I, Aytaç Göksu, state that:

- (a) I am a Professional Engineer (ing, P.Eng. QC) at: Golder Associés Ltée
7250, rue du Mile End, 3rd floor
Montreal, Quebec, Canada H2R3A4
- (b) This certificate applies to the technical report titled “Feasibility Study for the Windfall Project, Eeyou Istchee James Bay, Québec, Canada” with an effective date of: 25 November 2022 (the “Technical Report”).
- (c) I am a “qualified person” for the purposes of National Instrument 43-101 (“NI 43-101”). My qualifications as a qualified person are as follows. I am a graduate of Joseph Fourier University and ENSHMG Engineering school (Grenoble, France) with a civil engineering bachelor degree and geoscience masters degree, major in hydraulics and hydrology, graduated in 2003, member of Engineers and Geoscientists of British Columbia (EGBC) and Ordre des ingénieurs du Québec (OIQ). My relevant experience after graduation and over 15 years for the purpose of the Technical Report includes numerous hydrologic analyses and modelling, design and planning of water management and erosion and sediment control measures, development of water management plans, and preparation of drawings and specifications for permitting, tender and construction for all stages of mine development, from baseline to closure studies and from preliminary economic assessment to detailed design. I have participated in the development of a number of NI-43-101 documents, for both preliminary economic assessments and feasibility design levels.
- (d) My most recent personal inspection of each property described in the Technical Report occurred on 5 and 6 October 2022 and was for a duration of 2 days.
- (e) I am responsible for Sections 5.3, 18.23, 18.23.1 and 20.2.5 of the Technical Report.
- (f) I am independent of the issuer as described in section 1.5 of NI 43-101.
- (g) My prior involvement with the property that is the subject of the Technical Report is as follows: I have participated as a Qualified Person to the NI 43-101 Technical Report for the Preliminary Economic Assessment of the Windfall Project dated April 26, 2022
- (h) I have read NI 43-101 and the part of the Technical Report for which I am responsible has been prepared in compliance with NI 43-101; and
- (i) At the effective date of the Technical Report, to the best of my knowledge, information, and belief, the parts of the Technical Report for which I am responsible contain(s) all scientific and technical information that is required to be disclosed to make the Technical Report not misleading.

Dated at Montréal, Québec, Canada on 10 January 2023.

Signed and sealed original on file

Aytaç Göksu, ing. P.Eng. (QC) OIQ#5033990



CERTIFICATE OF QUALIFIED PERSON

Frédéric Choquet, P.Eng., MAsC, PMP

This certificate applies to the NI 43-101 Technical Report entitled "Feasibility Study for the Windfall Project, Eeyou Istchee James Bay, Québec, Canada" (the "Technical Report"), prepared for Osisko Mining Inc., dated January 10, 2023, with an effective date of November 25, 2022.

I, Frédéric Choquet, P.Eng., PMP., as a co-author of the Technical Report, do hereby certify that:

1. I am a Team Coordinator in Mine Waste geotechnics with WSP Canada Inc., located at 1600 Boulevard René-Levesque, Québec, Canada.
2. I am a graduate (Engineering Bachelor) of École Centrale de Lyon, France and I have a Master in Applied Sciences in Mining Engineering from Ecole Polytechnique de Montréal, Québec, Canada.
3. I am a member in good standing of the Ordre des Ingénieurs du Québec (OIQ No. 5030251). I hold the credential of Project Management Professional (PMP) from the Project Management Institute (PMI No. 6192573).
4. My relevant experience includes the design, construction and operation of tailings storage facility or mine waste and their related water management infrastructure. I worked on preliminary, pre-feasibility and feasibility studies as well as detailed engineering projects. I worked as project manager and tailings engineer for a total of twelve (12) years.
5. I have read the definition of "qualified person" set out in the NI 43-101 – Standards of Disclosure for Mineral Projects ("NI 43-101") and certify that, by reason of my education, affiliation with a professional association, and past relevant work experience, I fulfill the requirements to be a qualified person for the purposes of NI 43-101.
6. I am independent of the issuer applying all the tests in Section 1.5 of NI 43-101.
7. I am author and responsible for Sections 18.4, 18.23.2, 18.24, 18.25; 20.1, except sections about Hydrogeology and Underground Water Quality, 20.2.2, 20.2.3, 20.2.6, 20.3, 20.4, 20.5; and 21.4.5. I am also co-author for the relevant portions of Chapters 1, 2, 3, 25, 26, 27 and Sections 21.1.3.1.8 and 21.1.4.4 of the Technical Report.
8. I have visited the Windfall Project site that is the subject of the Technical Report on September 27th and 28th, 2022.
9. I have had no prior involvement with the property that is the subject of the Technical Report.
10. I have read NI 43-101 and the sections of the Technical Report for which I am responsible have been prepared following NI 43-101 rules and guidelines.
11. As at the effective date of the Technical Report, to the best of my knowledge, information and belief, the sections of the Technical Report for which I am responsible contain all scientific and technical information that is required to be disclosed to make the portions of the Technical Report for which I am responsible not misleading.

Signed and sealed this 10th day of January, 2023.

"Signed and sealed original on file"

Frédéric Choquet, P.Eng., MAsC, PMP
WSP Golder



CERTIFICATE OF QUALIFIED PERSON

Andréanne Hamel, P.Eng.

This certificate applies to the NI 43-101 Technical Report entitled "Feasibility Study for the Windfall Project, Eeyou Istchee James Bay, Québec, Canada" (the "Technical Report"), prepared for Osisko Mining Inc., dated January 10, 2023, with an effective date of November 25, 2022.

I, Andréanne Hamel, P.Eng., as a co-author of the Technical Report, do hereby certify that:

1. I am a Professional Engineer (ing., P.Eng. QC) with WSP Canada Inc., located at 1135 Lebourgneuf Québec City, QC, Canada, GK2 0M5.
2. I am a graduate of UQAM university of Montreal with a B.Sc. in Geology (1996) and from Laval University of Quebec City with a B.Eng. (1999) and M.Sc. (2002) in Geological engineering.
3. I am a member in good standing of Ordre des ingénieurs du Québec (OIQ no128249).
4. I have practiced my profession since 2002, for a total of 20 years since my graduation. I have significant experience in environmental impact assessment (EIA) for mining projects, especially in hydrogeology including groundwater infiltration and baseline studies for soil and groundwater. I have worked on many EIA for mining projects in different regions in the province of Québec. For this project, I have been directly involved in the groundwater infiltration estimation, and baseline studies.
5. I have read the definition of "qualified person" set out in the NI 43-101 – Standards of Disclosure for Mineral Projects ("NI 43-101") and certify that, by reason of my education, affiliation with a professional association, and past relevant work experience, I fulfill the requirements to be a qualified person for the purposes of NI 43-101.
6. I am independent of the issuer applying all the tests in Section 1.5 of NI 43-101.
7. I am author and responsible for the preparation of Section(s) 16.3 and 20.1.2.2 (Hydrogeology and Baseline Groundwater Quality). I am also co-author and responsible for the relevant portions of Chapters 1, 2, 3, 25, 26 and 27 of the Technical Report.
8. I have visited the Windfall Property that is the subject of the Technical Report, on September, 28, 2022 as part of this current mandate.
9. I have had no prior involvement with the Windfall Project that is the subject of the Technical Report.
10. I have read NI 43-101 and the sections of the Technical Report for which I am responsible have been prepared following NI 43-101 rules and regulations.
11. As at the effective date of the Technical Report, to the best of my knowledge, information and belief, the sections of the Technical Report for which I am responsible contain all scientific and technical information that is required to be disclosed to make the portions of the Technical Report for which I am responsible not misleading.

Signed and sealed this 10th day of January, 2023.

Original signed and sealed on file

Andréanne Hamel, P.Eng.
WSP Canada Inc.



CERTIFICATE OF QUALIFIED PERSON

Isabelle Larouche, P. Eng.

This certificate applies to the NI 43-101 Technical Report entitled "Feasibility Study for the Windfall Project, Eeyou Istchee James Bay, Québec, Canada" (the "Technical Report"), prepared for Osisko Mining Inc., dated January 10, 2023, with an effective date of November 25, 2022.

I, Isabelle Larouche, P. Eng., as a co-author of the Technical Report, do hereby certify that:

1. I am a senior metallurgical engineer with WSP Canada, located at 1300, Guillaume-Couture boulevard, Lévis (Québec), Canada.
2. I am a graduate of the Laval University (Québec, Canada), with a Bachelor of Science in Materials and Metallurgical Engineering in 2006.
3. I am a member in good standing of the Ordre des ingénieurs du Québec (OIQ License #142262).
4. My relevant experience includes fifteen (15) years in mineral processing flowsheet development and plant design, metallurgical testwork supervision, plant equipment costs estimation and plant operating costs estimation. I have been involved in numerous gold and tailings filtration projects.
5. I have read the definition of "qualified person" set out in the NI 43-101 – Standards of Disclosure for Mineral Projects ("NI 43-101") and certify that, by reason of my education, affiliation with a professional association, and past relevant work experience, I fulfill the requirements to be a qualified person for the purposes of NI 43-101.
6. I am independent of the issuer applying all the tests in Section 1.5 of NI 43-101.
7. I am author and responsible for the preparation of Sections 13.4, 17.4, 17.5 and 21.2.4.2. I am also co-author and responsible for the relevant portions of Chapters 1, 2, 3, 25, 26 and 27 of the Technical Report.
8. I have not visited the Windfall Property that is the subject of the Technical Report.
9. I have had prior involvement with the property that is the subject of the Technical Report. I have contributed to the NI 43-101 Technical Report for the Preliminary Economic Assessment of the Windfall Project for Osisko Mining Inc., issued on April 26th, 2021.
10. I have read NI 43-101 and the sections of the Technical Report for which I am responsible have been prepared following NI 43-101 rules and regulations.
11. As at the effective date of the Technical Report, to the best of my knowledge, information and belief, the sections of the Technical Report for which I am responsible contain all scientific and technical information that is required to be disclosed to make the portions of the Technical Report for which I am responsible not misleading.

Signed and sealed this 10th day of January, 2023.

Original signed and sealed on file

Isabelle Larouche, P. Eng.
WSP Canada



CERTIFICATE OF QUALIFIED PERSON

Éric Poirier, P.Eng., PMP

This certificate applies to the NI 43-101 Technical Report entitled "Feasibility Study for the Windfall Project, Eeyou Istchee James Bay, Québec, Canada" (the "Technical Report"), prepared for Osisko Mining Inc., dated January 10, 2023, with an effective date of November 25, 2022.

I, Éric Poirier, P.Eng., PMP, as a co-author of the Technical Report, do hereby certify that:

1. I am an Electrical Engineer and Project Manager with WSP Canada Inc. located at 1075, 3rd Avenue East, Val-d'Or, Québec, Canada.
2. I am a graduate of Université du Québec à Chicoutimi in Electrical Engineering in 1996 (B.Sc), Chicoutimi, Québec, Canada.
3. I am a member of the Ordre des Ingénieurs du Québec (OIQ No. 120063), Professional Engineers Ontario (PEO No. 100112909) and Northwest Territories and Nunavut Association of Professional Engineers and Geoscientists (NAPEG No. L2229). I hold the credential of Project Management Professional (PMP) from the Project Management Institute (PMI No. 6115196).
4. I have worked as project manager and electrical engineer for a total of twenty-four (24) years. My expertise was acquired while working as multi-disciplinary project manager, mining infrastructure designer and discipline lead, including surface infrastructure design, electrical distribution and communications.
5. I have read the definition of "qualified person" set out in the NI 43-101 – Standards of Disclosure for Mineral Projects ("NI 43-101") and certify that, by reason of my education, affiliation with a professional association, and past relevant work experience, I fulfill the requirements to be a qualified person for the purposes of NI 43-101.
6. I am independent of the issuer applying all the tests in Section 1.5 of NI 43-101.
7. I am author and responsible for Sections 18.1 to 18.3, 18.5, 18.7 to 18.17, 18.18.6, 18.19, 21.1.3.1.4, 21.1.3.1.6, 21.1.3.1.7 Area 665 & Process Plant Earthworks, 21.1.4.1, and 21.1.4.3. I am also co-author for the relevant portions of Chapters 1, 2, 25, 26, 27 of the Technical Report.
8. I have visited the Windfall Project site that is the subject of the Technical Report on October 6, 2020
9. I have had prior involvement with the property that is the subject of the Technical Report. I have contributed to the NI 43-101 Technical Report for the Preliminary Economic Assessment of the Windfall Project for Osisko Mining Inc., issued on August 1, 2018, and on April 26, 2022.
10. I have read NI 43-101 and the sections of the Technical Report for which I am responsible have been prepared following NI 43-101 rules and guidelines.
11. As at the effective date of the Technical Report, to the best of my knowledge, information and belief, the sections of the Technical Report for which I am responsible contain all scientific and technical information that is required to be disclosed to make the portions of the Technical Report for which I am responsible not misleading.

Signed and sealed this 10th day of January, 2023.

"Signed and sealed original on file"

Éric Poirier, P.Eng., PMP
WSP Canada Inc.



TABLE OF CONTENTS

1. Summary	1-1
1.1. Contributors	1-1
1.2. Key Project Outcomes	1-3
1.3. Property Description and Ownership	1-4
1.3.1. Windfall, Urban-Barry and Urban Duke Properties.....	1-4
1.4. Geology	1-6
1.4.1. Windfall and Urban-Barry Properties.....	1-6
1.5. Property History.....	1-7
1.6. Data Verification.....	1-8
1.7. Mineral Resource Estimate	1-8
1.8. Mineral Reserve Estimate	1-13
1.9. Mining Methods	1-15
1.10. Mineral Processing and Metallurgical Testing	1-15
1.10.1. Process Flowsheet.....	1-16
1.10.2. Metal Recovery Projections.....	1-16
1.11. Project Infrastructure	1-18
1.11.1. Tailings Management Facility	1-21
1.11.2. Water Management Infrastructure	1-21
1.11.3. Waste Rock, Ore and Overburden Storage	1-21
1.12. Environmental and Permitting	1-22
1.13. Market Studies and Contracts	1-22
1.14. Capital and Operating Costs Estimates.....	1-23
1.15. Project Economics	1-24
1.16. Project Schedule and Organization	1-25
1.17. Interpretations and Conclusions	1-26
1.17.1. Risks and Opportunities	1-26
1.18. Recommendations	1-28
2. Introduction	2-1
2.1. Basis of Technical Report	2-1
2.2. Report Responsibility and Qualified Persons.....	2-2
2.3. Effective Dates and Declaration	2-5
2.4. Sources of Information	2-6
2.4.1. General.....	2-6



2.4.2.	A2CG	2-7
2.4.3.	BBA	2-7
2.4.4.	Entech.....	2-8
2.4.5.	GCM.....	2-8
2.4.6.	PLR Resources Inc.	2-9
2.4.7.	WSP and Golder.....	2-9
2.5.	Site Visits	2-11
2.5.1.	Windfall Project Site	2-11
2.5.2.	SGS Laboratory (Québec City)	2-12
2.6.	Currency, Units of Measurement, and Calculations	2-12
2.7.	Definitions.....	2-13
2.8.	Acknowledgement	2-13
3.	Reliance on Other Experts	3-1
3.1.	Mineral Tenure and Surface Rights	3-1
3.2.	Taxation and Royalties	3-1
4.	Property Description and Location	4-1
4.1	Introduction	4-1
4.2	Location	4-1
4.3	Mining Rights in Québec	4-3
4.3.1	The Claim.....	4-3
4.3.2	The Mining Lease	4-4
4.4	Mining Title Status and Royalties	4-4
4.4.1	Windfall Property.....	4-4
4.4.2	Urban-Barry Property	4-18
4.4.3	Urban Duke Property	4-25
4.5	Royalties	4-27
4.5.2	Urban Duke Property	4-28
4.6	Constraints and Restrictions.....	4-28
4.6.1	Windfall, Urban-Barry and Urban Duke Properties.....	4-28
4.7	Permits and Environmental Liabilities.....	4-28
5.	Accessibility, Climate, Local Resources, Infrastructure and Physiography	5-1
5.1	Accessibility	5-1
5.2	Local Resources and Infrastructure	5-1
5.3	Climate.....	5-4
5.4	Physiography	5-5



5.5	Windfall Site	5-5
5.6	Community	5-9
5.6.1	Human Environment	5-9
5.6.2	Information and Public Consultation Process	5-9
6.	History	6-1
6.1	Windfall Property	6-1
6.1.1	Summary of Historical Work.....	6-1
6.1.2	Mineral Resource Estimates	6-5
6.2	Urban-Barry Property (Western, Central, Eastern and Southern Sectors)	6-6
6.2.1	Previous Work	6-6
7.	Geological Setting and Mineralization.....	7-1
7.1.	Regional Geology.....	7-1
7.2.	Windfall and Urban-Barry Properties.....	7-1
7.2.1.	Local Geology	7-1
7.2.2.	Windfall Property Geology.....	7-3
7.3.	Alteration	7-4
7.4.	Structural Geology.....	7-6
7.5.	Mineralization Styles and Relative Timing.....	7-9
7.6.	Mineralized Zones	7-12
8.	Deposit Types.....	8-1
8.1.	Windfall Deposit	8-1
8.2.	Intrusion-associated Gold Deposits	8-1
9.	Exploration	9-1
10.	Drilling.....	10-1
10.1	Windfall Project	10-1
10.1.1	Overview.....	10-1
10.1.2	Drilling Methods.....	10-6
10.1.3	Field Procedures.....	10-7
10.1.4	Geological Logging.....	10-7
10.1.5	Core Recovery	10-8
10.1.6	Collar Surveys	10-8
10.1.7	Drill Hole Validation.....	10-8
10.1.8	Drill Spacing.....	10-9
10.2	Exploration Drilling, Urban-Barry Property.....	10-9
10.3	Conclusions.....	10-12



11. Sample Preparation, Analyses and Security	11-1
11.1 Windfall and Urban-Barry Properties.....	11-1
11.1.1 Laboratories Accreditation and Certification	11-1
11.1.2 Historical Sampling.....	11-2
11.1.3 Osisko Core Handling, Sampling and Security.....	11-2
11.1.4 Lithogeochemical Samples Procedure	11-4
11.1.5 Analytical Methods.....	11-4
11.1.6 Quality Assurance and Quality Control (QA/QC) Programs.....	11-7
11.2 Conclusion	11-27
12. Data Verification	12-1
12.1 Site Visits	12-1
12.2 Sample Preparation, Analytical, QA/QC and Security Procedures.....	12-1
12.3 Drill Hole Database	12-6
12.3.1 Drill Hole Location	12-6
12.3.2 Downhole Survey	12-6
12.3.3 Assays.....	12-6
12.4 Conclusion	12-7
13. Mineral Processing and Metallurgical Testing	13-1
13.1 Introduction	13-1
13.2 Windfall Historical Testwork	13-1
13.2.1 PEA (2021) Mineralogical Study.....	13-2
13.2.2 MRE (2021) and PEA (2021) Comminution Testwork.....	13-2
13.2.3 MRE (2021) and PEA (2021) Gravity Recovery Testwork	13-4
13.2.4 MRE (2021) and PEA (2021) Leaching Testwork	13-6
13.2.5 MRE (2021) Detoxification Testwork.....	13-9
13.3 Windfall Recent Testwork	13-9
13.3.1 Sample Selection and Compositing	13-9
13.3.2 Mineralogical Study.....	13-12
13.3.3 Comminution Testwork.....	13-12
13.3.4 Gravity Testwork.....	13-13
13.3.5 Leaching Testwork	13-15
13.3.6 Oxygen Demand	13-18
13.3.7 Detoxification Testwork	13-18
13.4 Tailings Thickening, Filtration and Paste Production Testwork	13-19
13.4.1 Historical Testwork	13-19
13.4.2 Feasibility Study Testwork.....	13-31



13.5 Overall Recovery – Windfall.....	13-48
14. Mineral Resource Estimates	14-1
14.1 Methodology.....	14-2
14.2 Drill Hole Database	14-2
14.3 Geological Model.....	14-5
14.4 Interpretation of Mineralized Lenses.....	14-5
14.5 Mined-out Voids Model.....	14-7
14.6 Compositing and High-grade Capping	14-13
14.6.1 Compositing.....	14-13
14.6.2 High-grade Capping.....	14-14
14.7 Density	14-22
14.8 Block Model.....	14-24
14.9 Rock Coding and Sub-Celling.....	14-27
14.10 Variography and Search Ellipsoids	14-29
14.10.1 Variography	14-29
14.10.2 Search Ellipsoids	14-32
14.11 Grade Interpolation.....	14-35
14.12 Block Model Validation	14-39
14.12.1 Volume Validation.....	14-39
14.12.2 Visual Validation	14-39
14.12.3 Statistical Validation	14-39
14.13 Cut-off Parameters	14-41
14.14 Mineral Resource Classification	14-43
14.14.1 Mineral Resource Classification Definition	14-43
14.14.2 Mineral Resource Classification for the Windfall Gold Deposit	14-44
14.15 Mineral Resource Estimate	14-48
14.16 Comparison to Previous Mineral Resource Estimates.....	14-57
14.17 Mineralization Potential Upside	14-58
15. Mineral Reserve Estimates	15-1
15.1. Mineral Reserve Estimation Process	15-1
15.2. Stope Design Parameters	15-3
15.3. Preliminary Cut-off Grade Derivation	15-3
15.4. Preliminary Economic Potential	15-4
15.5. Final Economic Analysis	15-4



16. Mining Methods	16-1
16.1 Introduction	16-1
16.2 Rock Engineering	16-1
16.2.1 Geomechanical Rock Mass Conditions	16-1
16.2.2 Anticipated Rock Mass Behaviour	16-6
16.2.3 Geomechanical Guidelines for Mine Design	16-8
16.2.4 Dimension of Pillars	16-10
16.2.5 Backfill Strength Requirements	16-12
16.2.6 Seismic Conditions	16-12
16.2.7 Infrastructure Proximity Relative to Ore Body	16-13
16.2.8 Ground Support	16-14
16.3 Mine Hydrogeology	16-16
16.3.1 Hydrostratigraphic Unit and Groundwater Flow Conditions	16-17
16.3.2 Groundwater Inflow Estimation	16-18
16.3.3 Extent of Potential Drawdown	16-20
16.4 Proposed Mining Method	16-20
16.4.1 Longitudinal Longhole with Backfill	16-20
16.5 Underground Mining	16-21
16.5.1 Stope Design Methodology	16-21
16.5.2 Dilution and Mining Recovery	16-23
16.6 Development	16-26
16.6.1 Lynx Zone	16-28
16.6.2 Main Zone	16-29
16.6.3 Primary Infrastructure	16-31
16.6.4 Production Level Infrastructure	16-32
16.7 Development and Infrastructure	16-34
16.7.1 Development Schedule	16-34
16.8 Production	16-37
16.8.1 Stope Physicals	16-37
16.8.2 Longhole Drilling	16-38
16.8.3 Material Movement	16-40
16.8.4 Backfill	16-42
16.8.5 Mine Production Schedule Summary	16-43
16.9 Underground Mine Services	16-46
16.9.1 Electrical Services	16-46
16.9.2 Fuel Distribution Network	16-48
16.9.3 Permanent Mine Pumping Network	16-48



16.9.4	Compressed Air Network	16-51
16.9.5	Ventilation Network	16-51
16.10	Underground Mine Equipment.....	16-55
16.10.1	Mine Equipment List.....	16-55
16.11	Mine Personnel	16-57
17.	Recovery Methods.....	17-1
17.1	Process Plant Design Criteria	17-3
17.2	Process Plant Facilities Description	17-4
17.2.1	Crushing, Storage and Reclaim	17-4
17.2.2	Grinding Circuit and Gravity Recovery	17-5
17.2.3	Carbon-in-Pulp	17-8
17.2.4	Adsorption, Desorption and Recovery Circuit	17-9
17.2.5	Cyanide Destruction Circuit and Tailings Treatment.....	17-11
17.2.6	Process Plant Services Requirement	17-12
17.3	Reagent Systems.....	17-13
17.4	Tailings Filtration Plant Design Criteria	17-13
17.5	Tailings Filtration Plant Process Description	17-14
17.5.1	Summary	17-14
17.5.2	Thickening and Water Management	17-15
17.5.3	Filtration.....	17-16
17.5.4	Paste Production.....	17-16
17.5.5	Dry Stacking.....	17-17
17.5.6	Reagents and Compressed Air	17-17
17.6	Plant Control System.....	17-17
18.	Windfall Project Infrastructure.....	18-1
18.1	General	18-1
18.2	Off-site Access Road	18-4
18.3	Site Preparation.....	18-5
18.4	Geotechnical Studies.....	18-6
18.5	Site Access Control.....	18-7
18.6	First Aid / Mining Rescue	18-7
18.7	Camp Complex Area.....	18-7
18.8	Bulk Explosives Storage and Magazines.....	18-10
18.9	Fire Water System.....	18-10
18.10	Site Lighting.....	18-11



18.11 Truck Shop.....	18-11
18.12 Mobile Equipment – Surface	18-12
18.13 Fuel Storage and Distribution	18-13
18.14 Production Core Shack and Emergency Vehicle Storage.....	18-14
18.15 Domestic Waste Management and Storage.....	18-15
18.16 Potable Water	18-15
18.17 Sewage Treatment	18-16
18.18 Process Plant.....	18-16
18.18.1 Crushing Area.....	18-17
18.18.2 Crushed Ore Storage and Handling Area	18-17
18.18.3 Process Plant Area.....	18-17
18.18.4 Office Area.....	18-19
18.18.5 Warehouse and IOC Control Centre.....	18-20
18.18.6 Tailings Filtration and Paste Backfill Plant.....	18-21
18.19 On-site Roads	18-23
18.19.1 Service Roads.....	18-23
18.19.2 Haulage Roads	18-24
18.20 Electrical Infrastructure and Power Demand.....	18-24
18.20.1 Site Distribution	18-24
18.20.2 Power Demand.....	18-25
18.20.3 Emergency Power	18-25
18.21 Telecom and Industrial IT Infrastructure.....	18-26
18.21.1 Integrated Operations Centre (IOC)	18-26
18.22 Tailings Management Facility	18-26
18.22.1 Geotechnical Considerations	18-27
18.22.2 Tailings Management Facility Design and Strategy	18-27
18.23 Water Management	18-32
18.23.1 Water Management Infrastructure: Hydrological Design	18-33
18.23.2 Water Management Infrastructure Geotechnical Design	18-37
18.23.3 Water Treatment.....	18-38
18.24 Waste Rock Stockpile (WRS)	18-40
18.24.1 Design and General Considerations.....	18-40
18.24.2 General Design	18-41
18.24.3 Geotechnical Considerations	18-41
18.25 Ore, Topsoil and Overburden Stockpiles	18-42
18.25.1 Ore Stockpile.....	18-42



18.25.2	Topsoil and Organic Material Stockpile	18-42
18.25.3	Overburden Storage	18-43
19.	Market Studies and Contracts	19-1
19.1.	Introduction	19-1
19.2.	Market Studies	19-1
19.3.	Exchange Rate and Precious Metal Price Projections	19-1
19.4.	Contracts	19-4
19.5.	QP Note	19-4
20.	Environmental Studies, Permitting, and Social or Community Impact	20-1
20.1.	Environmental Baseline Studies	20-1
20.1.1.	General Description	20-2
20.1.2.	Baseline Conditions	20-4
20.2.	Ore, Waste Rock, Tailings and Water Management Requirements	20-11
20.2.1.	Geochemical Assessment	20-11
20.2.2.	Ore Management	20-14
20.2.3.	Waste Rock Management	20-14
20.2.4.	Tailings Management	20-15
20.2.5.	Water Management	20-15
20.2.6.	Site Monitoring	20-22
20.3.	Regulatory Context	20-22
20.3.1.	Environmental Impact Assessment Process	20-22
20.3.2.	Permitting Requirements	20-24
20.4.	Social or Community Considerations	20-29
20.4.1.	Consultation Activities	20-29
20.4.2.	Social Components	20-34
20.4.3.	Social Related Requirements	20-37
20.5.	Mine Closure Requirements	20-38
20.5.1.	Closure Concept	20-39
21.	Capital and Operating Costs	21-1
21.1	Capital Costs	21-1
21.1.1	Summary	21-1
21.1.2	Scope and Structure of Capital Cost Estimate	21-3
21.1.3	Pre-production Capital Costs	21-6
21.1.4	Sustaining Capital Costs	21-20
21.2	Operating Costs	21-26
21.2.1	Summary	21-26



21.2.2	Basis of Operating Cost Estimate	21-27
21.2.3	Mining.....	21-29
21.2.4	Process Plant	21-33
21.2.5	Waste and Water Management.....	21-39
21.2.6	General and Administration	21-41
21.3	Site Personnel Summary – All Areas	21-43
22.	Economic Analysis.....	22-1
22.1	Assumptions and Basis.....	22-1
22.2	Gold and Silver Production.....	22-3
22.3	Pre-production and Sustaining Capital Costs	22-4
22.4	Royalties	22-5
22.5	Taxation.....	22-5
22.5.1	Income and Mining Taxes.....	22-5
22.5.2	Carbon Taxes	22-6
22.6	Financial Analysis Summary	22-7
22.7	Production Costs.....	22-10
22.8	Sensitivity Analysis.....	22-11
23.	Adjacent Properties	23-1
23.1	Windfall and Urban-Barry Properties.....	23-1
23.1.1	Gladiator Gold Deposit - Bonterra Resources.....	23-1
23.1.2	Barry Gold Deposit - Bonterra Resources	23-1
23.1.3	Lac Rouleau - Osisko Mining Inc. (Formerly Beaufield Resources Inc.).....	23-2
24.	Other Relevant Data and Information	24-1
24.1.	Project Organization.....	24-1
24.1.1.	Engineering and Procurement	24-1
24.1.2.	Construction Management.....	24-2
24.1.3.	Project Execution Plan.....	24-5
25.	Interpretation and Conclusions.....	25-1
25.1.	Overview	25-1
25.2.	Resource Database.....	25-1
25.3.	Mineral Resources.....	25-2
25.4.	Mineral Reserves	25-3
25.5.	Mining Methods	25-3
25.6.	Metallurgy and Processing	25-3
25.6.1.	Process Flowsheet	25-4



25.6.2. Metal Recovery Projections	25-4
25.7. Infrastructure	25-6
25.7.1. Tailings Management Facility	25-8
25.7.2. Water Management	25-8
25.7.3. Waste Rock, Ore and Overburden Storage	25-9
25.7.4. Water Treatment Plant (WTP)	25-10
25.8. Environmental Studies	25-10
25.9. Market Studies and Contracts	25-10
25.10. Capital and Operating Costs	25-11
25.11. Indicative Economic Results	25-12
25.12. Execution Plan and Schedule	25-13
25.13. Project Risks and Opportunities	25-14
26. Recommendations	26-1
26.1. Exploration	26-2
26.1.1. Underground Definition Drilling	26-2
26.1.2. Conversion Drilling	26-3
26.1.3. Exploration Drilling	26-3
26.1.4. Bulk Sample in Lynx 4	26-3
26.1.5. Integration of Additional Types of Analysis in the Resource Block Model	26-3
26.2. Engineering Studies	26-4
26.2.1. Underground Mining	26-4
26.2.2. Metallurgical Testwork	26-5
26.2.3. Integrated Operations	26-5
26.2.4. Waste, Water and Tailings Management	26-6
26.2.5. Environment and Permitting	26-8
26.3. Market Studies and Contracts	26-8
26.4. Conclusion	26-8
27. References	27-1

APPENDICES

- Appendix A: List of claims 2022 – Windfall
- Appendix B: List of claims 2022 – Urban-Barry
- Appendix C: List of claims 2022 – Urban Duke



LIST OF TABLES

Table 1-1: Report contributors	1-1
Table 1-2: Windfall gold deposit Measured, Indicated, and Inferred Mineral Resources	1-10
Table 1-3: Windfall gold deposit Mineral Reserves.....	1-14
Table 1-4: Projected metallurgical recoveries values for Au and Ag.....	1-17
Table 1-5: Project capital cost summary ¹	1-23
Table 1-6: Project operating cost summary	1-24
Table 1-7: Key milestones	1-26
Table 1-8: Work program budget	1-29
Table 2-1: Qualified Persons and areas of report responsibility	2-2
Table 4-1: Property summary	4-1
Table 4-2: Mineral tenure summary of the Windfall property	4-6
Table 4-3: Mineral tenure summary of the Urban-Barry property.....	4-19
Table 4-4: Mineral tenure summary of the Urban Duke property	4-25
Table 6-1: Historical exploration work in the Windfall area and significant results.....	6-1
Table 6-2: Historical exploration work in the Urban-Barry area and significant results	6-8
Table 9-1: Summary of exploration work performed at the Windfall deposit and the Urban-Barry property	9-1
Table 10-1: Drill hole summary and number of assay samples delivered from 2015 to June 7, 2022 (Osisko)	10-3
Table 11-1: Analytical methods for gold assays used by Osisko	11-5
Table 11-2: Samples submitted to ALS for analysis along with primary samples	11-7
Table 11-3: Current sample QA/QC statuses in DHLogger	11-8
Table 11-4: Blanks submitted for analysis along with routine samples.....	11-10
Table 11-5: Certified standards values, 95% confidence limits for gold reference material (ppm) with fire assay.....	11-16
Table 11-6: Summary statistics between specific gravity GRA08b and bulk density methods ..	11-22
Table 11-7: ALS analytical quality control – Reference materials, blanks and duplicates	11-24
Table 11-8: Bureau Veritas analytical quality control – Reference materials, blanks and duplicates	11-25
Table 11-9: Gold method priority ranking	11-26
Table 13-1: Characteristics of microscopic gold for Underdog sample	13-2
Table 13-2: Grindability test average results.....	13-3
Table 13-3: Lynx and Zone 27 grindability test results	13-3
Table 13-4: Bulk gravity reconciled results	13-4



Table 13-5: Intensive leach results.....	13-5
Table 13-6: MRE (2021) Optimized leaching parameters.....	13-6
Table 13-7: Optimization leaching results	13-7
Table 13-8: Characteristics of microscopic gold for Triple Lynx, Lynx 4 and Gabbro sample	13-12
Table 13-9: Comminution test results per zone for recent testwork	13-13
Table 13-10: e-GRG recent testwork results	13-13
Table 13-11: e-GRG variability testwork results	13-14
Table 13-12: Bulk gravity reconciled results of recent testwork.....	13-14
Table 13-13: Gravity recovery at the mill discharge for each sample	13-15
Table 13-14: Leaching testwork for Triple Lynx and Lynx 4.....	13-16
Table 13-15: Leaching testwork to determine grinding size effect on zones selected for recovery calculations	13-17
Table 13-16: Leaching testwork to compare a Main-Lynx-Lynx 4-Triple Lynx-Underdog composite direct recovery and its calculated recovery from the curves.....	13-17
Table 13-17: Leaching testwork to evaluate Triple Lynx and Lynx 4 low-grade recoveries.....	13-18
Table 13-18: Oxygen Demand parameters and results	13-18
Table 13-19: Pressure filtration test results – Summary and design conditions	13-22
Table 13-20: Chemical composition (wt%)	13-22
Table 13-21: Mineralogical composition (phase wt%)	13-23
Table 13-22: Decanted water chemical analysis (ppm)	13-23
Table 13-23: Unconfined compressive test (UCS) results for July 2020 tailings.....	13-28
Table 13-24: Unconfined compressive test (UCS) results for March 2021 tailings.....	13-29
Table 13-25: Tailings physicochemical analysis	13-31
Table 13-26: Chemical composition (wt%)	13-31
Table 13-27: Semi-quantitative mineralogical composition (phase wt%)	13-32
Table 13-28: Bingham viscosity and yield stress summary for Tailings 37 µm sample.....	13-36
Table 13-29: UCS tests results	13-40
Table 13-30: Lynx bulk tailings physicochemical analysis	13-41
Table 13-31: Dynamic thickening results summary	13-43
Table 13-32: Lynx bulk tailings filtration tests parameters and results	13-46
Table 13-33: Overall gold and silver recovery with gravity and leach.....	13-48
Table 14-1: Mineralized zones included in areas reported in the MRE.....	14-3
Table 14-2: Number of mineralized envelopes modelled and reported per zone with their average thickness	14-5
Table 14-3: Statistics on gold raw assays presented by zone	14-14
Table 14-4: Statistics on silver raw assays presented by zone.....	14-15



Table 14-5: Compilation of gold capping limits applied to composites, by interpolation pass	14-17
Table 14-6: Compilation of silver capping limits applied to composites, by interpolation pass	14-19
Table 14-7: Summary statistics comparing the uncapped and capped gold composites, by zone	14-20
Table 14-8: Summary statistics comparing the uncapped and capped silver composites, by zone	14-21
Table 14-9: Density compilation for rock types coded in the block models	14-22
Table 14-10: Statistics on specific gravity by rock type	14-23
Table 14-11: Statistics on specific gravity assay results located inside mineralized lenses, by zone	14-23
Table 14-12: Median lithology values of specific gravity assay results located inside mineralized lenses, by zone	14-24
Table 14-13: Block models properties by zone	14-25
Table 14-14: Rock codes identified in the block models	14-28
Table 14-15: Variogram model parameters selected for each zone	14-30
Table 14-16: Search ellipsoid ranges defined by interpolation pass	14-34
Table 14-17: Composite search specifications by interpolation pass	14-36
Table 14-18: Comparison of the block and composite mean grades at a zero cut-off grade for blocks of all resource classes	14-40
Table 14-19: Parameters used to estimate the UCoG for the MRE	14-42
Table 14-20: Main criteria for resource classification	14-44
Table 14-21: Windfall gold deposit Mineral Resource inclusive of Mineral Reserves	14-49
Table 14-22: Windfall gold deposit Measured, Indicated, and Inferred mineral resources detailed by zone	14-51
Table 14-23: Windfall Project Measured, Indicated, and Inferred mineral resource sensitivity table	14-52
Table 14-24: Windfall Project, Measured, Indicated, and Inferred mineral resource by depth for the Main Underdog, and Triple 8 Areas	14-54
Table 14-25: Windfall Project, Measured, Indicated, and Inferred mineral resource by depth for the Lynx area	14-55
Table 14-26: Windfall Project, Measured, Indicated, and Inferred mineral resource by depth	14-56
Table 14-27: Comparison of the 2022 MRE to the previous October 2021 MRE	14-58
Table 15-1: Windfall gold deposit Mineral Reserves	15-2
Table 15-2: Cut-off grade inputs	15-3
Table 15-3: Preliminary Cut-off grades	15-4
Table 15-4: Stope economics parameters	15-4



Table 15-5: Feasibility Study operating costs and cut-off grade calculation for the Windfall Project.....	15-5
Table 16-1: In situ stress tensors considered for the Windfall Project.....	16-2
Table 16-2: Geomechanical domains considered for the Windfall Project	16-2
Table 16-3: Summary of available geotechnical data from drill holes for the Windfall Project ..	16-3
Table 16-4: Summary of laboratory test results per geomechanical domain	16-4
Table 16-5: Summary of mean joint set orientations per mining zone.....	16-5
Table 16-6: Summary of rock mass classification per mining zone	16-6
Table 16-7: Summary of ELOS estimates assuming the rock mass has yielded to 15% of its peak strength.....	16-10
Table 16-8: Development ground support recommendations	16-14
Table 16-9: Groundwater infiltration in mine openings – Baseline scenario	16-19
Table 16-10: Groundwater infiltration in mine openings – Upper range	16-19
Table 16-11: MSO Parameters	16-22
Table 16-12: Dilution factors.....	16-24
Table 16-13: Development profiles	16-27
Table 16-14: Development schedule	16-35
Table 16-15: Development metres per type per year	16-36
Table 16-16: Economic stope metrics.....	16-37
Table 16-17: Drill and blast daily rates	16-40
Table 16-18: Production loader productivity	16-41
Table 16-19: Paste backfill activity durations.....	16-43
Table 16-20: Windfall production plan	16-44
Table 16-21: Resource category breakdown.....	16-45
Table 16-22: Pumpstation operating details	16-50
Table 16-23: Ventilation demand estimate	16-52
Table 16-24: Primary ventilation fan summary	16-54
Table 16-25: Ventilation raise summary	16-54
Table 16-26: Productive working time calculation	16-55
Table 16-27: Mining equipment.....	16-56
Table 16-28: Underground personnel requirements	16-57
Table 17-1: Summary of key process design criteria.....	17-3
Table 17-2: Reagent mixing systems	17-13
Table 17-3: Tailings filtration plant design criteria.....	17-14
Table 18-1: Windfall off-site access road details	18-5
Table 18-2: Windfall borrow pits identification	18-5



Table 18-3: Mobile equipment list	18-12
Table 18-4: Propane storage tanks	18-13
Table 18-5: Waste material categories	18-15
Table 18-6: Process plant buildings	18-17
Table 18-7: Power demand by area	18-25
Table 18-8: Tailings production and main properties of the tailings	18-28
Table 18-9: Tailings deposition plan	18-29
Table 18-10: Hydrological and hydraulic design criteria – Ponds	18-34
Table 18-11: Hydrological and Hydraulic Design Criteria – Ditches.....	18-35
Table 18-12: Hydraulic design of the ponds	18-36
Table 20-1: Estimated average and maximum monthly flow rates to water treatment units....	20-21
Table 20-2: Preliminary and non-exhaustive list of permitting requirements	20-27
Table 21-1: Project pre-production capital cost summary ¹	21-2
Table 21-2: CAPEX estimate responsibilities by WBS	21-5
Table 21-3: Project pre-production capital cost summary	21-6
Table 21-4: General administration (Owner’s costs) pre-production capital cost summary	21-8
Table 21-5: Underground mine pre-production capital costs.....	21-9
Table 21-6: Electrical and communication pre-production capital costs.....	21-10
Table 21-7: Site infrastructure pre-production capital costs.....	21-11
Table 21-8: Process plant pre-production capital costs.....	21-12
Table 21-9: Tailings filtration and paste backfill plant pre-production capital costs	21-16
Table 21-10: Waste, water and tailings management pre-production capital costs	21-17
Table 21-11: Monte Carlo contingency simulation results	21-19
Table 21-12: Sustaining capital costs summary	21-21
Table 21-13: Sustaining capital costs breakdown.....	21-22
Table 21-14: Underground sustaining capital costs	21-23
Table 21-15: Mining surface infrastructure sustaining capital costs	21-24
Table 21-16: Waste, Water and Tailings management pre-production capital costs	21-25
Table 21-17: Site rehabilitation and closure capital costs.....	21-26
Table 21-18: Windfall Project operating cost summary	21-27
Table 21-19: OPEX estimate responsibilities.....	21-28
Table 21-20: General rate and unit cost assumptions	21-29
Table 21-21: Underground operating costs	21-30
Table 21-22: Overview of the underground operating costs per year.....	21-31
Table 21-23: Process plant operating costs	21-33
Table 21-24: Reagents – Application and consumption.....	21-34



Table 21-25: Estimated grinding media consumption.....	21-35
Table 21-26: Process plant salaried personnel	21-35
Table 21-27: Process plant hourly personnel.....	21-36
Table 21-28: Process plant power demand by area	21-37
Table 21-29: Windfall filtration plant operating costs	21-38
Table 21-30: Waste and water management operating costs.....	21-40
Table 21-31: Water treatment operating costs	21-40
Table 21-32: General and administrative costs.....	21-43
Table 21-33: Project site personnel (average) – All areas.....	21-44
Table 22-1: Financial model parameters	22-3
Table 22-2: Financial analysis summary (pre-tax and after-tax)	22-7
Table 22-3: Windfall Project financial model summary	22-8
Table 22-4: Production cost summary	22-11
Table 22-5: NPV sensitivity results (after-tax) for metal price and exchange rate variations	22-12
Table 22-6: IRR sensitivity results (after-tax) for metal price and exchange rate variations	22-12
Table 22-7: NPV sensitivity results (after-tax) for operating and capital cost variations.....	22-13
Table 22-8: IRR sensitivity results (after-tax) for operating and capital cost variations.....	22-13
Table 22-9: NPV sensitivity results (after-tax) for discount rate.....	22-13
Table 24-1: Key project activities	24-5
Table 25-1: Projected metallurgical recoveries values for Au and Ag.....	25-5
Table 25-2: Project capital cost summary ¹	25-11
Table 25-3: Project operating cost summary	25-12
Table 25-4: Project risks (preliminary risk assessment)	25-14
Table 25-5: Project opportunities	25-21
Table 26-1: Work program budget	26-1

LIST OF FIGURES

Figure 1-1: Windfall Project site locations.....	1-5
Figure 1-2: Windfall Project layout	1-18
Figure 4-1: Location of the Windfall Project and the Osisko claims.....	4-2
Figure 4-2: Land tenure plan showing the various original agreements	4-5
Figure 4-3: Net smelter return royalty agreements for the Windfall property	4-7
Figure 4-4: Claim map of the Windfall (in gray) and Urban-Barry properties	4-21
Figure 5-1: Map of the Windfall property area showing various access routes	5-2



Figure 5-2: Topography and accessibility of the Windfall Project properties	5-3
Figure 5-3: Aerial photograph showing the Windfall Camp	5-7
Figure 6-1: Historical drill holes categorized by company within the Windfall property	6-4
Figure 6-2: Exploration history in the Urban-Barry Greenstone Belt outside of the Windfall	6-7
Figure 7-1: Simplified geology map of the Archean Abitibi Subprovince and the locations of the Windfall and Urban-Barry properties	7-2
Figure 7-2: Regional geologic map of the Urban-Barry greenstone belt and the location of the Windfall, Urban-Barry and Urban-Barry (Duke) claim boundaries.....	7-3
Figure 7-3: Examples of the proximal alteration assemblages observed in drill core at the Windfall deposit.....	7-5
Figure 7-4: Interpreted surface geology of the Windfall gold deposit	7-8
Figure 7-5: Main types of mineralization observed at the Windfall deposit.....	7-10
Figure 7-6: Representative images of visible gold observed in vein-type (A-D) and replacement-type (E) mineralization at the Windfall deposit	7-11
Figure 7-7: Surface projection of the mineralized zones of the Windfall deposit and the locations of drill holes (Osisko) grouped by year	7-13
Figure 7-8: Leapfrog 3D modelling longitudinal section (looking northwest) illustrating the geometry of the mineralized zones plunging 35° to the northeast, exploration is open at depth for all zones.....	7-15
Figure 7-9: Simplified northwest-southeast vertical cross-section of the geology of the Lynx area of the Windfall deposit	7-16
Figure 7-10: Simplified northwest-southeast vertical cross-section of the geology of the Main area of the Windfall deposit	7-17
Figure 10-1: Windfall property map showing drill holes completed from 2015 to June 7, 2022 by Oban Mining Corporation and Osisko Mining	10-2
Figure 10-2: Representative geological cross-section showing the distribution of drill hole spacing and orientation in the Lynx area	10-4
Figure 10-3: Representative geological cross-section showing the distribution of drill hole spacing and orientation in the Main area.....	10-5
Figure 10-4: Exploration drilling (2016-2022) and the location of the informal sectors in Urban-Barry	10-12
Figure 11-1: Time series plot for blank samples assayed by ALS (AA24 Method)	11-11
Figure 11-2: Time series plot for blank samples assayed by ALS (AA26 Method)	11-11
Figure 11-3: Time series plot for blank samples assayed by Bureau Veritas (FA450 Method)	11-12
Figure 11-4: Time series plot for blank samples assayed by Bureau Veritas (FA550 Method)	11-12
Figure 11-5: Time series plot for blank samples assayed by ALS (GRA22 Method)	11-13
Figure 11-6: Time series plot for blank samples assayed by Bureau Veritas (FS652 Method)	11-13
Figure 11-7: Time series plot for blank samples assayed by ALS (SCR24 Method)	11-14



Figure 11-8: Time series plot for blank samples assayed by ALS (SCR24G Method)	11-14
Figure 11-9: Results of standard OREAS 218 using AA26 Method.....	11-18
Figure 11-10: Results of standard OREAS 221 using AA26 Method.....	11-18
Figure 11-11: Results of standard OREAS 239 using AA26 Method.....	11-19
Figure 11-12: Results of standard OREAS 228 using AA26 Method.....	11-19
Figure 11-13: Post 2014 mineral resource estimate laboratory pulp duplicates for gold (g/t) ...	11-21
Figure 11-14: Laboratory specific gravity (GRA08b) and internal bulk density measurement correlation (Eagle Hill and Osisko).....	11-23
Figure 11-15: ALS pulp duplicates for Windfall samples (AA26)	11-24
Figure 11-16: Bureau Veritas pulp replicates (Method FA450)	11-25
Figure 12-1: Drill collar review during a QP site visit.....	12-2
Figure 12-2: Visit of an active drill on site during a QP site visit	12-2
Figure 12-3: A) and B) Sample preparation room; C) and D) Samples ready for shipment to the laboratory	12-3
Figure 12-4: A) and B) Core review in the core logging facility, with C) Sample tags; and D) Identification tags	12-4
Figure 12-5: A) Underground visit; B) Observed mineralization; C) and D) Multiple examples of visible gold in muck samples from the Lynx Bulk sample area	12-5
Figure 13-1: Plan view of the recent testwork sample hole locations	13-10
Figure 13-2: View looking N040 of the recent testwork sample hole locations.....	13-10
Figure 13-3: Plan view of all sample hole locations	13-11
Figure 13-4: View looking N040 of all sample hole locations.....	13-11
Figure 13-5: Yield stress vs. wt% solids.....	13-20
Figure 13-6: Apparent viscosity vs. shear rate	13-20
Figure 13-7: Shear stress vs. shear rate.....	13-21
Figure 13-8: Static yield stress vs. mass concentration	13-24
Figure 13-9: Boger slump vs. mass concentration.....	13-24
Figure 13-10: Cemented July 2020 tailings rheogram	13-25
Figure 13-11: Cemented March 2021 tailings rheogram	13-25
Figure 13-12: Uncemented July 2020 tailings rheogram	13-26
Figure 13-13: Uncemented March 2021 tailings rheogram	13-26
Figure 13-14: Bingham yield stress vs. mass solids concentration.....	13-27
Figure 13-15: Plastic viscosity vs. mass solids concentration	13-27
Figure 13-16: UCS test results.....	13-29
Figure 13-17: Water-to-binder ratio curves with “Type GU” binder	13-30
Figure 13-18: Water-to-binder ratio curves with “TerraFlow” binder.....	13-30



Figure 13-19: %Solids vs. slump for Tailings 37 μm sample	13-33
Figure 13-20: Static yield stress vs. %solids for Tailings 37 μm sample	13-34
Figure 13-21: Water bleed and yield stress vs. time for Tailings 37 μm sample	13-35
Figure 13-22: Plug yield stress for Tailings 37 μm sample	13-35
Figure 13-23: Bingham yield stress results for sample Tailings 37 μm sample	13-36
Figure 13-24: Bingham viscosity results for sample Tailings 37 μm sample	13-37
Figure 13-25: Flow loop data summary	13-38
Figure 13-26: Pipeline yield stress vs. wt% solids	13-38
Figure 13-27: Pipeline viscosity vs. wt% solids	13-39
Figure 13-28: UCS results for samples Tailings 37 and 20 μm	13-41
Figure 13-29: Lynx bulk tailings flocculant screening results.....	13-42
Figure 13-30: Historical underflow solids content comparison for different P_{80}	13-44
Figure 13-31: 190-mm pilot yield stress and underflow values produced during run time	13-45
Figure 13-32: 190-mm pilot yield stress vs. underflow solids content	13-45
Figure 13-33: Drying time effect on cake moisture	13-47
Figure 13-34: Filtration rate vs. cake moisture	13-47
Figure 13-35: Main zone gold recovery curve	13-49
Figure 13-36: Lynx zone gold recovery curve	13-50
Figure 13-37: Underdog zone gold recovery curve	13-50
Figure 13-38: Lynx 4 zone gold recovery curve	13-51
Figure 13-39: Triple Lynx zone gold recovery curve	13-51
Figure 13-40: Main zone silver recovery curve.....	13-52
Figure 13-41: Lynx zone silver recovery curve.....	13-52
Figure 13-42: Underdog zone silver recovery curve	13-53
Figure 13-43: Lynx 4 zone silver recovery curve.....	13-53
Figure 13-44: Triple Lynx zone silver recovery curve	13-54
Figure 14-1: Diamond drill holes in the Windfall database used for the resource estimate	14-4
Figure 14-2: Mineralized domains modelled in the Windfall deposit	14-8
Figure 14-3: Unmineralized late dikes and modelled lenses in the Windfall deposit	14-9
Figure 14-4: Lynx mineralized zones in the Windfall deposit	14-10
Figure 14-5: Main zone mineralized zones in the Windfall deposit.....	14-11
Figure 14-6: Exploration ramp intersecting mineralization of the Windfall deposit	14-12
Figure 14-7: Examples of three-step gold grade capping on composites using a grade distribution probability plot	14-16
Figure 14-8: Bounding boxes of the block models.....	14-27
Figure 14-9: Example of variogram model in the Lynx Main zone – Major high-grade lenses ...	14-31



Figure 14-10: Example of the structural data collected through Leapfrog on lens 3450, Lynx 4, and used for the dynamic anisotropy search process	14-33
Figure 14-11: Gold grade distribution in mineralized lens 3388, Lynx Main zone	14-37
Figure 14-12: Gold grade distribution in mineralized lens 4103, Underdog area	14-38
Figure 14-13: Cross-section swath plots by mineralization zone	14-41
Figure 14-14: Example of resource classification for blocks in lens 3311 in Lynx Main zone	14-46
Figure 14-15: Example of blocks discarded or included in the mineral resource in lens 3308, Lynx Main zone	14-47
Figure 14-16: Long section view (looking northwest) showing the distribution of the block grades of the Windfall Mineral Resource	14-53
Figure 14-17: Long section view (looking northwest) showing the distribution of the blocks by resource category for the Windfall Mineral Resource	14-54
Figure 14-18: Several gold anomalous intervals intercepted at depth.....	14-59
Figure 14-19: Long-term potential along the main plunge of the Windfall deposit	14-60
Figure 16-1: Production layout example	16-21
Figure 16-2: Dilution and mining recovery	16-23
Figure 16-3: Estimated unplanned dilution (%)	16-25
Figure 16-4: Estimated total dilution (%)	16-25
Figure 16-5: Mining recovery (%)	16-26
Figure 16-6: Windfall development design	16-28
Figure 16-7: Lynx zone development design	16-29
Figure 16-8: Main zone development design	16-30
Figure 16-9: Primary ramp systems and shared infrastructure	16-31
Figure 16-10: Typical level layout	16-33
Figure 16-11: Typical level truck loading arrangement	16-33
Figure 16-12: Mineral Reserve Ounces per Vertical Metre.....	16-38
Figure 16-13: General arrangement for downhole stope design	16-39
Figure 16-14: General arrangement for uphole stope design.....	16-40
Figure 16-15: Truck haulage requirements	16-41
Figure 16-16: Average major activity quantities by year and mining area	16-42
Figure 16-17: Pumping stations	16-49
Figure 16-18: Primary mine ventilation system	16-53
Figure 17-1: Simplified process flow diagram	17-2
Figure 17-2: Process plant feeding circuit	17-4
Figure 17-3: SAG mill circuit.....	17-6
Figure 17-4: Gravity circuit	17-7



Figure 17-5: CIP circuit	17-9
Figure 17-6: Tailings filtration plant simplified flowsheet	17-15
Figure 17-7: Proposed control system topology	17-19
Figure 18-1: Windfall complete site layout	18-3
Figure 18-2: Windfall Project layout	18-4
Figure 18-3: Camp complex layout	18-8
Figure 18-4: First Nations cultural centre layout	18-9
Figure 18-5: Traditional teepee image	18-9
Figure 18-6: Fire water pump station layout	18-10
Figure 18-7: Truck shop layout (first floor)	18-12
Figure 18-8: Production core shack and emergency vehicle storage layout	18-14
Figure 18-9: Plan view of the process plant	18-18
Figure 18-10: Plan view of the mine and process dry layout	18-19
Figure 18-11: Plan view of 1 st floor office	18-20
Figure 18-12: Plan view of warehouse and control centre	18-21
Figure 18-13: Tailings filtration and paste backfill plant layout	18-22
Figure 18-14: Service road – Typical cross-section	18-23
Figure 18-15: Haulage road – Typical cross-section.....	18-24
Figure 18-16: Plan view of the tailings management facility	18-30
Figure 18-17: Typical cross-section of the tailings management facility	18-31
Figure 18-18: Surface water management infrastructure final layout – Windfall Mine Site	18-33
Figure 18-19: Simplified water treatment process diagram	18-39
Figure 19-1: Historical average monthly gold price (USD/oz)	19-2
Figure 19-2: Historical average monthly silver price (USD/oz)	19-3
Figure 20-1: Environmental and social study areas	20-3
Figure 20-2: Surface water management infrastructures final layout – Windfall Mine Site.....	20-17
Figure 20-3: Water balance conceptual flow diagram – Phase 1	20-19
Figure 20-4: Water balance conceptual flow diagram – Phase 2	20-20
Figure 21-1: Annual and cumulative project capital costs	21-3
Figure 21-2: Distribution of pre-production capital costs	21-6
Figure 21-3: Preproduction capital cost estimate Monte Carlo Simulation Results	21-20
Figure 21-4: Project sustaining capital cost summary	21-21
Figure 22-1: Payable gold and silver production (oz)	22-4
Figure 22-2: Overall Windfall Project capital cost profile	22-5
Figure 22-3: Life of mine cash flow projection (cumulative, pre-tax and after-tax)	22-10
Figure 22-4: Sensitivity of the net present value (after-tax) to financial variables	22-14



Figure 22-5: Sensitivity of the internal rate of return (after-tax) to financial variables	22-15
Figure 23-1: Properties and deposits in the vicinity of the Windfall and Urban-Barry properties as of October 11, 2022	23-3
Figure 24-1: General Project Engineering, Procurement and Construction Management team organizational chart	24-4
Figure 24-2: Mine Development and Construction workforce forecast	24-6



List of Abbreviations

Abbreviation	Description
3D	Three dimensional
A2GC	Andrieux & Associates Geomechanics Consulting LP
AA	Atomic absorption
AACEI	Association for the Advancement of Cost Engineering
AAS	Atomic absorption spectroscopy
ADR	Adsorption-desorption-recovery
Ag	Silver
Agency	Canadian Environmental Assessment Agency
Ai	Abrasion index
AIS	Air insulated switchgear
AISC	All-in sustaining cost
Al	Aluminum
Al ₂ O ₃	Aluminium oxide
Alcudia	Alcudia Capital Incorporated
ALS	ALS Minerals
Alto	Alto Ventures Ltd.
AMD	Acid mine drainage
APS	Azimuth Pointing System
ARBJ	<i>Administration Régionale Baie James</i>
ARD	Acid rock drainage
As	Arsenic
ASD	Apitisiwin Skills Development
Au	Gold
B	Billion
Ba	Barium
BaO	Barium oxide
BBA	BBA Inc.
BBU	Baseband Unit
Be	Beryllium
Beaufield	Beaufield Resources Inc.
BFS	Blast furnace slag
BHP&M	Borehole pulse electromagnetic
Bi	Bismuth
BLK	Blank
BTS	Indirect splitting tensile strength (Brazilian test)



List of Abbreviations

Abbreviation	Description
BV	Bureau Veritas Commodities Canada Ltd.
BWi	Bond work index
Ca	Calcium
Ca(OH) ₂	Hydrated lime / Calcium hydroxide
CAD or \$	Canadian dollar (examples of use: CAD2.5M / \$2.5M)
CaO	Lime
CAPEX	Capital expenditure
CCTV	Closed-circuit television
Cd	Cadmium
Ce	Cerium
CFNW	Cree First Nation of Waswanipi
CIL	Carbon in leach
CIM	Canadian Institute of Mining, Metallurgy and Petroleum
CIP	Carbon-in-pulp
CL	Core length
CMT	Construction management team
CN	Cyanide
CNT	Total cyanide
CND	Cyanide destruction
CNG	Cree Nation Government
CN _{WAD}	Weak acid dissociable cyanide
CO	Carbon monoxide
Co	Cobalt
CO ₂ eq	Carbon dioxide equivalent
CoA	Certificate of authorization
COG	Cut-off grade
COMEV	Evaluating Committee (Environmental and Social Impact)
COMEX	Review Committee (Environmental and Social Impact)
conc.	Concentrate
CP	Collection pond
CPB	Cemented paste backfill
CPC[EO]	<i>Critères de prévention de la contamination [eau / organisme aquatique]</i> (Prevention of contamination of aquatic organism)
Cr	Chromium
Cr ₂ O ₃	Chromium(III) oxide



List of Abbreviations

Abbreviation	Description
CRF	Cemented rockfill
CRM	Certified reference material
Cs	Cesium
CTA	Cree Trappers Association
Cu	Copper
Cu ²⁺	Copper (II) ion
CuSO ₄	Copper sulphate
CVAA	<i>Critère de vie aquatique aigu</i> (aquatic life, acute effect)
CVAC	<i>Critère de vie aquatique chronique</i> (aquatic life, chronic effect)
CV	Coefficient of variation
CWi	Crushing work index
D _{xx}	XX% - Particle size distribution
DAF	dissolved air flotation
DDH	Diamond drill hole
Directive 019	<i>Directive 019 sur l'industrie minière</i> (Provincial guidelines for the mining industry)
DMZ	Demilitarized Zone
DO	Dissolved oxygen
DUP	Duplicate
DWT	Drop weight test
Dy	Dysprosium
EC	<i>Water consumption (eau de consommation)</i>
ECCC	Environment and Climate Change Canada
ECD	Equivalent Circular Diameter
EDF	Environmental Design Flood
EDO	Environmental discharge objectives
EGL	Effective grinding length
e-GRG	Extended gravity recoverable gold
EIA	Environmental Impact Assessment
EIJB	Eeyou Istchee James Bay
ELOS	Equivalent linear overbreak/slough
EM	Electromagnetic
ENE	east north-east
Entech	Entech Mining Ltd.
EPC	Evolved Packet Core
EPCM	Engineering, Procurement, Construction Management



List of Abbreviations

Abbreviation	Description
EQA	Environmental Quality Act
Er	Erbium
ESG	Environmental, Social, and Corporate Governance
et al.	et alla (and others)
Eu	Europium
EW	Electrowinning
F ₈₀	80% passing - Feed size
Fe	Iron
Fe ₂ O ₃	Iron(III) oxide
FEL	Frequent effect concentration
FFP	Fast-opening filter press
Freewest	Freewest Resources Canada Ltd.
FS	Feasibility study
FW	Footwall
G&A	General and Administration
Ga	Gallium
GCM	GCM Consultants Inc.
Gd	Gadolinium
Ge	Germanium
GESTIM	<i>Gestion des titres miniers</i>
GM	<i>Gîte minier</i> (geological assessment report)
Gold Royalties	Gold Royalties Corporation
Golder	Golder Associates Ltd.
Gpa	Gigapascal
GRG	Gravity recoverable gold
H ₂ S	Sulphide (as H ₂ S)
HCl	Hydrochloric acid
HCT	High compression test
HDPE	High density poly ethylene
Hf	Hafnium
HG	High-grade
Hg	Mercury
HHW	Hazardous Household Waste
Ho	Holmium
HQ	HQ- Caliber drill hole



List of Abbreviations

Abbreviation	Description
HRT	High-rate thickening
HV	High-voltage
HVAC	Heating, ventilation, and air conditioning
HW	Hanging wall
IAA	Impact Assessment Act
IBA	Impact and benefit agreement
ICP	Inductively coupled plasma
ICP-AES	Inductively coupled plasma atomic emission spectroscopy (also referred to as inductively coupled plasma optical emission spectrometry)
ICP-MS	Inductively coupled plasma mass spectroscopy
ICS	Industrial Control System
ID2	Inverse distance square
IDF	Inflow Design Flood
IDMZ	Industrial Demilitarized Zone
IEC	International Electrotechnical Commission
ILR	Intensive leaching reactor
In	Indium
I/O	Input/output
IOC	Integrated Operations Centre
IP	Induced Polarization
IROC	Integrated Remote Operation Centre
IRR	Internal rate of return
ISO	International Organization for Standardization
IT	Information technology
JBACE	James Bay Advisory Committee on the Environment
JBNQA	James Bay and Northern Quebec Agreement
Jw	Joint water reduction factor
K	Potassium
K	Thousand
K ₂ O	Potassium oxide
K ₈₀	80% passing – Particle size
La	Lanthane
LED	Light emitting diode
LHD	Load haul dump
Li	Lithium



List of Abbreviations

Abbreviation	Description
LLDPE	Linear Low Density Polyethylene
LOI	Loss of ignition
LOM	Life of mine
LTE	Long Term Evolution (network)
Lu	Lutecium
LXM	Lynx
M	Million
M&I	Measured and Indicated
Ma	Mega annum (million years)
MAG	Magnetic
MBBR	Moving bed bioreactor
MCC	Motor Control Centres
MDDEP	<i>Ministère du Développement durable, de l'Environnement et des Parcs du Québec</i>
MDMER	Metal and Diamond Mining Effluent Regulations
MELCCFP	<i>Ministère de l'Environnement, de la Lutte contre les changements climatiques, de la Faune et des Parcs</i>
MERN	<i>Ministère de l'Énergie et Ressources naturelles</i> (Ministry of Energy and Natural Resources)
MFFP	<i>Ministère des Forêts, de la Faune et des Parcs</i>
MFP	Membrane filter presses
MRNF	<i>Ministère des Ressources naturelles et des Forêts</i> (Natural Resources and Forests)
Mg	Magnesium
MgO	Magnesium oxide
MMS	Mineralized material stockpile
MMW	Minimum mining width
Mn	Manganese
MnO	Manganese(II) oxide
Mo	Molybdenum
MPa	Mega pascals
MRE	Mineral Resource Estimate
MSO	Mineable Stope Optimizer
MTOs	Material take-offs
Na	Sodium
Na ₂ O	Sodium oxide
NaCN	Sodium cyanide



List of Abbreviations

Abbreviation	Description
NAM Group	North American Exploration Inc. (50%), Garry Majerle (25%) and Michel Lavoie (25%) collectively.
NaOH	Sodium hydroxide
Nb	Niobium
Nd	Neodymium
NE	Northeast
NH ₃	Ammonia
Ni	Nickel
NN	Nearest Neighbour
NNE	North northeast
No.	Number
NO ₂	Nitrogen dioxide
Noront	Noront Resources Ltd.
NPR	Net profits royalty
NPV	Net present value
NQ	NQ- Caliber drill hole
NS	North-south
NSA	Non-significant assay
NSR	Net smelter return
NTS	National Topographic System
NVZ	Northern Volcanic Zone
O ₂	Oxygen
OEL	Occasional effect concentration
OGQ	<i>Ordre des Géologues du Québec</i>
OIQ	<i>Ordre des Ingénieurs du Québec</i>
OIT	Operator interface terminal
OK	Ordinary kriging
OPEX	Operational expenditure
OPGW	Optical Ground Wire
OREAS	Ore Research & Exportation Pty Ltd. Assay Standards
Osisko	Osisko Mining Inc.
P	Phosphor
P ₂ O ₅	Phosphorus pentoxide
P ₈₀	80% passing - Product size
PAG	Potentially acid generating



List of Abbreviations

Abbreviation	Description
Pb	Lead
Pb(NO ₃) ₂	Lead nitrate
PCS	Process control system
PC	Personal computer
PEA	Preliminary economic assessment
PEL	Probable effect level
PFMEA	Potential failure modes and effects assessment
pH	Potential of hydrogen
PLC	Programmable logic controller
PLR	PLR Resources Inc.
PMP	Probable maximum precipitation
PoC	Push-to-Talk-over-Cellular
Pr	Praseodymium
PSD	Particle size distribution
QA/QC	Quality Assurance / Quality Control
QEM	Quantitative Evaluation of Materials
QFP	Quartz-feldspar porphyry
QP	Qualified person
Rb	Rubidium
Re	Rhenium
Rec	Recovery
REL	Rare effect concentration
REP	Replicate
RES	<i>Résurgence dans l'eau de surface</i> (groundwater resurgence)
RL	Reduced level
RMR	Rock mass rating
ROM	Run-of-mine
ROW	Right-of-way
RQD	Rock quality designation
RROHS	Québec Regulation Respecting Occupational Health and Safety in Mines
RRU	Remote Radio Unit
RWi	Rod work index
S	Sulphur
S ₂	Sulphide
SABC	Semi-autogenous ball mill crusher



List of Abbreviations

Abbreviation	Description
SAG	Semi-autogenous grinding
Sb	Antimony
Sc	Scandium
Scandium	Scandium International Mining Corp.
SCN	Thiocyanate
SCSE	SAG Circuit Specific Energy
SD	Standard deviation
Se	Selenium
SEDAR	System for electronic document analysis and retrieval
SG	Specific gravity
Si	Silicon
SIGÉOM	<i>Système d'information géominière du Québec</i>
Sigra	Sigra Pty Ltd.
Silverwater	Silverwater Capital Corporation
SiO ₂	Silicon dioxide / silica
Sm	Samarium
SMC	SAG mill comminution
Sn	Tin
SO ₂	Sulphur dioxide
SPT	Standard penetration test
Sr	Strontium
SRF	Stress reduction factor
SrO	Strontium oxide
Std	Standard S.U.
SW	Southwest
Ta	Tantalum
Tb	Terbium
TCS	Confined triaxial compressive strength
TDEM	Time-domain electromagnetic
Te	Tellurium
TEL	Threshold effect level
Th	Thorium
Ti	Titanium
TIMA	TESCAN Integrated Mineral Analyzer
TiO ₂	Titanium dioxide



List of Abbreviations

Abbreviation	Description
TIR	<i>Table interministérielle régionale</i>
TI	Thallium
TLX	Triple Lynx
Tm	Thulium
TMF	Tailings management facility
t/m ³	Tonne per cubic metre
TSF	Tailings storage facility
TSS	Total solids in suspension
U	Uranium
U/F	Underflow
UCoG	Underground cut-off grade
UCS	Unconfined compressive strength
UCSE	Unconfined compressive strength with measurements of elastic properties
UG	Underground
UPS	Uninterruptible Power Supply
USD or US\$	United States dollar (examples of use: USD2.5M / US\$2.5M)
UTM	Universal Transverse Mercator
V	Vanadium
V1	Felsic volcanic
V2	Intermediate to mafic volcanic
V30	Reamed bore 30 inches in diameter
VDT	Value driver tree
Virginia	Virginia Mines Inc.
VM	Virtual machine
VPA	Vertical Plate
vs.	Versus
VTEM™	Airborne electromagnetic survey
W	Tungsten
w/w	Weight per weight
WAD	Weak acid dissociable
WAN	Wide area network
WBS	Work breakdown structure
WGC	World Gold Council
WMI	Water management infrastructure
WRS	Waste rock stockpile



List of Abbreviations

Abbreviation	Description
WSP	WSP Canada Inc.
WTP	Water treatment plant
XRD	X-Ray Diffraction
XRF	X-Ray Fluorescence
Y	Yttrium
Yb	Ytterbium
Zn	Zinc
Zr	Zirconium



List of Abbreviations – Units of Measurement

Unit	Description
σ	sigma
\$M	Million Canadian dollars
\$/t	Dollars per tonne
%	Percent
% solids	Percent solids by weight
°C	Degrees Celsius
μm	micron
cm	centimetre
CFM	cubic feet per minute
d	day (24 hours)
dBA	A-weighting decibel
ft	feet (12 inches)
g	gram
g/L	grams per Litre
g/t	grams per tonne
GWh	Gigawatt hour
h	hour (60 minutes)
ha	Hectare
hp	horsepower
K	thousand
k	kilo
kCFM	Thousand cubic feet per minute
kg	kilogram
kg/h	kilograms per hour
kg/t	kilograms per tonne
KL/y	kiloliter per year
km	kilometre
kN	kilonewton
kPa	kilopascal
kt	kilotonne
kW	kilowatt
kWh/t	kilowatt hour per tonne
L	Litre
M	million
m	metre



List of Abbreviations – Units of Measurement

Unit	Description
m/d	metres per day
m/s	metres per second
m ²	square metre
m ³	cubic metre
m ³ /d	cubic metre per day
mesh	US Mesh
mg	milligram
min	minute (60 seconds)
MLpy	million litres per year
mm	millimetre
mRL	metre Reduced Level
Mt	million tonne
MW	megawatt
Ø	diameter
oz	troy ounces
Pa	pascal
Pa-s	pascal-second
ppm	parts per million
s	second
t	tonne (1,000 kg) (metric ton)
t/m	Tonnes per meter
tpd	tonnes per day
tph	tonnes per hour
tpy	tonnes per year
V	Volt
W	Watt
wt%	weight percent
y	year (365 days)



1. Summary

Osisko Mining Inc. (“Osisko”) commissioned BBA Inc. (“BBA”), in April 2022, to prepare a technical report (the “Report”) of the Feasibility Study, herein also referred to as the “FS” or the “Study”, for the Windfall Project (“Project”) an advanced stage gold exploration project located in the Eeyou Istchee James Bay (“EIJB”) region of central-northwest Québec, Canada.

This report was completed by BBA with the assistance of a number of specialized consultants, including A2GC – Andrieux & Associates Geomechanics Consulting L.P (“A2GC”), Entech Mining Ltd. (“Entech”), GCM Consultants Inc. (“GCM”), Golder Associates Ltd. (“Golder”), and WSP Canada Inc. (“WSP”). This report was prepared according to the guidelines set out under the requirements of National Instrument 43-101 Standards of Disclosure for Mineral Projects (“NI 43-101”) to support the results of the Study as disclosed in Osisko’s press release entitled “Osisko Mining Delivers Positive Feasibility Study for Windfall” dated November 28, 2022.

The FS provides a base case assessment for developing the Windfall deposit as underground mine with a processing plant (3,400 tpd nominal) at the site.

All monetary units in the Study are in Canadian dollars (CAD or \$), unless otherwise specified. Costs are based on fourth quarter (Q4) 2022 dollars. Quantity and grades are rounded to reflect that the reported values represent approximations.

1.1. Contributors

The major FS contributors and their respective areas of responsibility are presented in Table 1-1.

Table 1-1: Report contributors

Qualified Person / Consulting Firm	General overview of responsibilities
Andrieux & Associates Geomechanics Consulting LP (A2GC)	
Patrick Andrieux, P.Eng.	<ul style="list-style-type: none"> ■ Rock mass characterization and rock engineering in support of the underground mine design
BBA Inc.	
Mathieu Bélisle, P.Eng. Colin Hardie, P.Eng.	<ul style="list-style-type: none"> ■ Metallurgical test work management and analysis ■ Crusher and process plant mass and water balance ■ Process plant design and cost (CAPEX and OPEX) ■ Electrical distribution infrastructure design and costs (on-site) ■ Integrated Operations Centre (IOC) design and costs ■ General and administration (G&A) operating costs ■ Project execution plan and schedule



Qualified Person / Consulting Firm	General overview of responsibilities
	<ul style="list-style-type: none">■ IT and communications infrastructure design and costs (supply and on-site)■ Financial Analysis■ NI 43-101 integration
Entech Mining Ltd.	
Patrick Langlais, P.Eng.	<ul style="list-style-type: none">■ Underground mine design, underground infrastructure, ventilation, paste backfill distribution■ Production scheduling■ Underground capital costs and operating costs■ Mineral Reserve estimate
GCM Consultants Inc.	
Mélissa Tremblay, P.Eng.	<ul style="list-style-type: none">■ Water treatment plant design, capital and operating costs
PLR Resources Inc.	
Pierre-Luc Richard, P.Geo.	<ul style="list-style-type: none">■ Historical data review■ Current and historical geology, exploration, drilling■ Sample preparation, QA/QC, and data verification■ Geological modelling and Mineral Resource estimate
WSP Canada Inc.	
Frédéric Choquet, P.Eng. Andréanne Hamel, P.Eng. Isabelle Larouche, P.Eng. Éric Poirier, P. Eng., PMP	<ul style="list-style-type: none">■ Site utilities & services, design and costs■ Off-site access road to Windfall, inspection and costs■ On-site roads and pads, design and costs■ Site utilities & services electrical, design and costs■ Surface ore, waste rock, overburden and topsoil management facility, design and costs■ Surface water management infrastructure, design and costs■ Geotechnical input for infrastructure design■ Hydrogeology and groundwater quality input for environmental studies■ Hydrogeology input to underground mine design■ Tailings thickening, filtration and paste preparation test work analysis■ Tailings filtration plant and dry tailings storage/handling, design and costs■ Environmental studies, permitting and closure costs■ Regulatory context, social considerations, and anticipated environmental issues



Qualified Person / Consulting Firm	General overview of responsibilities
Golder Associates Ltd	
Yves Boulianne, P.Eng. Ken De Vos, P.Geo. Aytaç Göksu, P.Eng.	<ul style="list-style-type: none"> ■ Surface tailings management facility, design and costs ■ Geotechnical input for TSF design ■ Geochemical characterization of waste rock, overburden, tailings, and ore ■ Site wide water balance ■ Water management infrastructure

1.2. Key Project Outcomes

The reader is advised that the results of the FS summarized in this report are intended to provide an initial, high-level review of the Project and potential design options. The FS mine plan and economic model include numerous assumptions. There is no guarantee the Project economics described herein will be achieved.

The following list details the key project outcomes of the Study:

- Total Proven and Probable Mineral Reserves of 12.2 million tonnes grading 8.06 g/t Au and 4.18 g/t Ag resulting in 3.16 million ounces of gold and 1.64 million ounces of silver;
- Mine life of 10 years, with peak year payable production of 374,000 ounces (Year 2), average life of mine ("LOM") annual payable production of 294,000 ounces of gold;
- Gold payable recovery of 93.1%;
- Payable production (LOM) of 2.94 million Au ounces and 1.37 million Ag ounces;
- Pre-production construction costs of \$788.6M, including a \$49.5M contingency;
- Sustaining costs of \$652.3M (including \$83.3M in closure costs and salvage value of (\$18.7M));
- Operating cost (total) of \$176.67 per tonne milled;
- All-in sustaining costs* of USD758/oz net of by-product credits, including royalties, over LOM;
- Gross revenue of \$6.2 billion and an after-tax operating cash flow of \$1.7 billion LOM;
- Net present value ("NPV") of \$1.7B at a 5% discount rate, and an IRR of 40.1% before taxes and mining duties;
- LOM taxes of \$0.7B and royalties of \$127M;
- NPV of \$1.2B at a 5% discount rate, and an internal rate of return ("IRR") of 33.8% after taxes and mining duties;
- Pay-back after-start of production period of 2.0 years pre-tax and 2.0 years after-tax;



- Over 1,000 workers during the construction period and more than 670 permanent jobs (including contractors) will be required during operations;
- Process plant construction planned for Q2 2024 with ramp-up beginning in Q3 2025.
 - * All-in sustaining costs are presented as defined by the World Gold Council ("WGC") less Corporate G&A.

1.3. Property Description and Ownership

The Windfall Project comprises two different sites: The Windfall and the Urban-Barry properties. The Windfall and Urban-Barry properties are located 115 km east of the town of Lebel-sur-Quévillon in the EIJB region of central-northwest Québec, Canada, approximately 620 km north-northwest of Montréal and 155 km northeast of Val-d'Or, as shown on Figure 1-1.

1.3.1. Windfall, Urban-Barry and Urban Duke Properties

The Windfall property is 100% owned by Osisko. On October 11, 2022, the Windfall property consisted of 286 individual claims covering an aggregate area of 12,523 ha. The current property was consolidated from several agreements concluded with previous owners.

The main claim blocks inherited from the original agreement are: The Windfall-Noront Option (including the Windfall, Alcane, and South blocks), the 29 Claims Expansion, the 184 Claims Expansion, the Rousseau property, the Windfall 2010, the Windfall 2012, and the Carat Claim. Osisko now holds a 100% interest on all the claim blocks of the property, barring various royalties. The Mineral Resources discussed herein are located within the Noront-Windfall block of the Windfall option and the 29 Claims Expansion claim blocks.

The Urban-Barry property is 100% owned by Osisko Mining Inc. On October 11, 2022, the property comprised 1,372 individual claims covering an aggregate area of approximately 74,135 ha. The property is mostly constituted of claims acquired at different periods from 2015 to 2022 and are subject to various royalties.

The Urban Duke property is a joint venture between Bonterra Resources (70% interest) and Osisko (30% interest). The property comprises 81 individual claims covering an aggregate area of approximately 3,590 ha. Claims were acquired through the acquisition of Beaufield Consolidated Resources resulting in Osisko becoming successor to Beaufield's interest in the Urban Duke property. Claims are subject to various royalties.

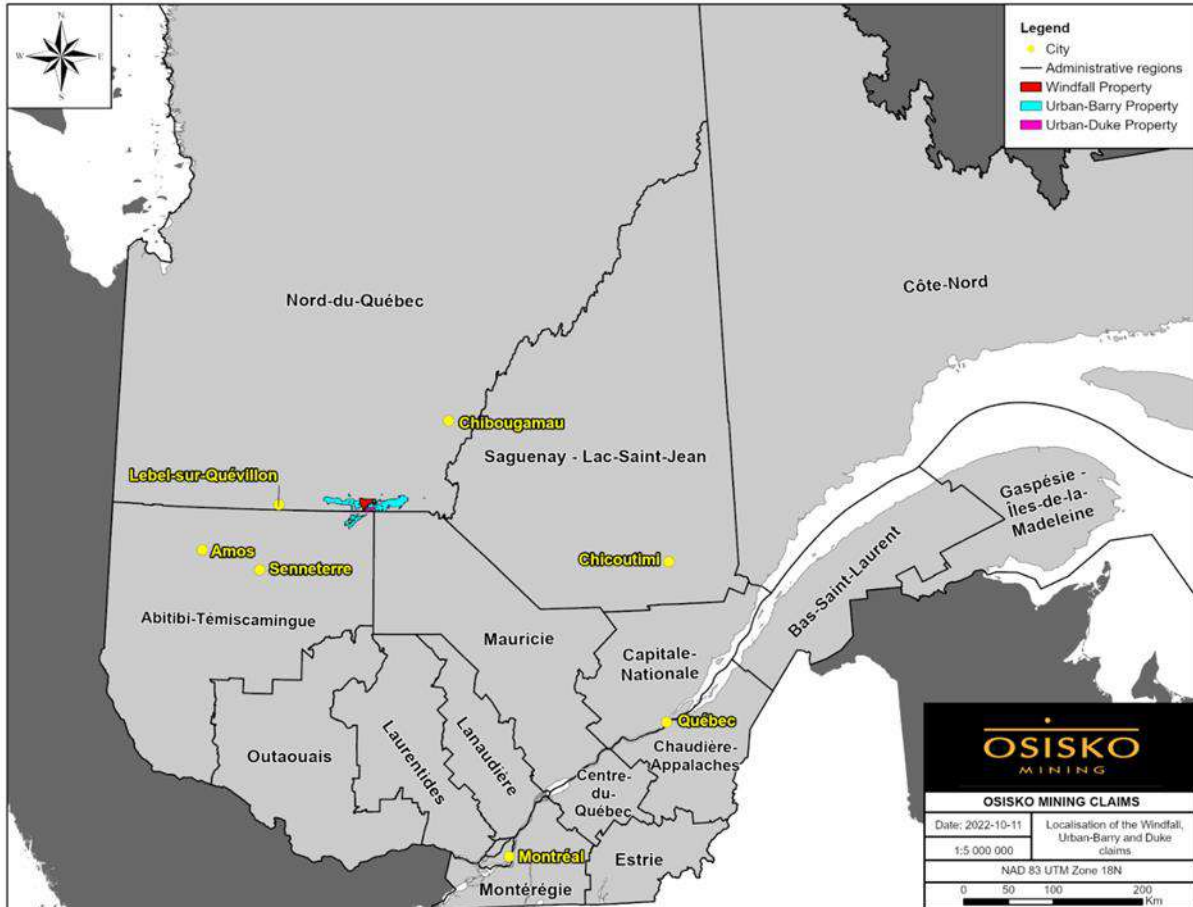

Figure 1-1: Windfall Project site locations

The Windfall property and the northern half of the Urban-Barry property are in the EIJB territory. Osisko has obtained all necessary permits and certifications from government agencies to allow for surface drilling, exploration, and bulk sampling on the Windfall property. The Windfall area is serviced by a complete network of well-maintained logging roads and hosts several infrastructure components at the Windfall property including an exploration camp with a capacity for 300 people. An experienced mining workforce is available in Lebel-sur-Quévillon and several well-established nearby mining towns, such as Val-d'Or, Rouyn-Noranda, La Sarre, Matagami and Chibougamau.



1.4. Geology

1.4.1. Windfall and Urban-Barry Properties

The Urban-Barry greenstone belt contains mixed mafic- to felsic volcanic rocks with lesser sedimentary deposits that are cross-cut by several east- and east-northeast trending deformation zones. The Windfall property is located in the central part of the Urban-Barry belt and is located along the Mazères deformation zone, which is a regional-scale east-northeast trending ductile deformation zone that is interpreted to be a second-order structure to the east-west trending Urban deformation zone.

The Urban-Barry belt is informally divided into the Fecteau, Chanceux, Macho, and Urban Formations. The Windfall deposit is hosted within the Windfall Member of the Macho Formation, which primarily consists of felsic and intermediate volcanic rocks, including tuff and lava units of tholeiitic affinity. In the Windfall deposit area, the stratigraphy trends northeast and dips moderately towards the southeast. Volcanic rocks are intruded by a series of younger quartz-feldspar porphyry dikes, commonly referred to as quartz-feldspar porphyry (“QFP”) dikes.

At Windfall, the bulk of the gold mineralization is contained in extensive anastomosed networks of quartz-pyrite veins and pyrite-rich alteration zones.

The resources are defined from surface to a depth of 1,600 m. The resources excluding the deeper zone Triple 8 (“TP8”) are defined from surface to a depth of 1,200 m. The MRE is separated into four areas: Lynx (including Lynx Main, Lynx HW, Lynx SW, Triple Lynx, and Lynx 4 zones), Main (including Zone 27, Caribou 1, Caribou 2, Caribou Extension, Bobcat, Mallard, Windfall North, and F-Zones zones), Underdog, and Triple 8. All areas trend east-northeast and plunge roughly 40°.

Most of the Lynx mineralization is contained in an extensive anastomosed network of quartz-pyrite veins hosted within silica-sericite-pyrite altered felsic volcanic rock, gabbros, and felsic QFP intrusions. This system is mainly located in the central portion and the southern limb of an open fold plunging at 40° towards the east-northeast along the Bank fault-shear zone. It also coincides with the global plunge of most of the mineralized zones at Windfall.

The Main and Underdog areas are separated by a thick, low-angle, post-mineral granodiorite intrusion called “Red Dog”. The Main area is located in the hanging wall, above the Red Dog intrusion, and is constrained along east-northeast oriented contacts of narrow subvertical granodioritic dikes within tilted volcanic rocks. Most mineralized envelopes in the Main area are associated with pyrite veinlets and stockworks hosted in silica-sericite-pyrite alteration zones occurring near contacts between volcanic rocks and felsic QFP intrusions.



The Underdog area is located in the footwall, beneath the Red Dog intrusion. The mineralization in the Underdog area is composed of quartz-pyrite veins hosted in sericite-silica-pyrite alteration zones that commonly follow the QFP intrusive contacts. The top of this deeper mineral zone starts at around 600 m depth and continues to depths of roughly 1,200 m. The mineralization continues to be open at depth and down-plunge.

From the early stages of exploration in the Windfall area, the recognition of a strong spatial and temporal relationship between gold and QFP porphyry dikes has led to the proposal that the Windfall deposit is a magmatic-hydrothermal system. The Windfall deposit is characterized as an intrusion-associated gold deposit due to the presence of unique mineralogical assemblages and the temporal and spatial association of gold with intrusive phases. The occurrence of porphyry dikes is an important criterion for the localization of the mineralization as they are proposed to have generated structural conduits in the deformed host volcanic sequence forming ideal structural traps for the mineralizing fluids.

1.5. Property History

The Windfall property is at an advanced stage of exploration. However, the vast Urban-Barry property is still at an early stage.

The properties' areas have seen a great deal of historical exploration work spanning from 1943 to 2009, with no historical resource estimates or production for that period. The Windfall property area saw renewed exploration activities from 2009 to 2014 by Eagle Hill Exploration, producing three Mineral Resource Estimates ("MREs") and a preliminary economic assessment ("PEA") on the property. From 2018 to 2022, four Mineral Resource Estimates and two PEAs were produced based on exploration activities conducted by Osisko.

The 2021 Urban-Barry and Windfall Exploration drilling program was conducted from January to December. In all, a total of 113 drill holes were drilled for a total of 65,237 m. Seven main areas were visited from January to June, namely Bank Extension, Windfall SW, Fold, Fox, Golden Bear (formerly known as Cross Fault), Windfall West and WUDZ. The second part of the program, starting in July, focused on the newly discovered Golden Bear showing.

The 2022 Windfall Exploration drilling program began in May and was still in progress as of June 7, 2022. Drilling was carried out by G4 Drilling. A total of 16 drill holes were drilled. A total of 6,950 m out of the 20,000-m program was drilled. The Golden Bear and Windfall West areas were visited.

From October 19, 2015 to June 7, 2022, Osisko completed 4,222 drill holes for a total of 1,677,534 m of drilling on the Windfall deposit. The 2022 drilling program was designed to better define the mineralized lenses, with a high priority on expanding and refining the Lynx zones. The Caribou 2, Mallard, F-Zones and Underdog zones were also targeted with infill drilling campaigns.



1.6. Data Verification

Pierre-Luc Richard, P. Geo., visited the Windfall Project on January 28 and 29, 2021, as well as on January 22 and 23, 2022, and on July 22 and 23, 2022 as part of the current mandate. The purpose of the visits was to review the Windfall Project with the Osisko team.

The 2021-2022 site visits included visual inspections of core, a tour of the core storage facility, underground visits, a survey of numerous drill hole casings in the field, and discussions with geologists from Osisko. The qualified person (“QP”) was also able to see drills in action on-site during some of the site visits.

A review of assaying, QA/QC and drill hole procedures, downhole survey methodologies, and descriptions of lithologies, alterations and structures was also completed during the site visits.

The QP was granted access to the original assay certificates directly from the laboratories for all holes drilled by Osisko since the last MRE on the Project. The assays recorded in the database were compared to the original certificates from the different laboratories and no discrepancies were detected.

The QP is of the opinion that the drilling, sampling, and assaying protocols in place are adequate and followed CIM Definition Standards. The data verification shows that the resource database for the Windfall Project is of good overall quality.

In the QP’s opinion, the Project database has been adequately validated and is suitable for use in the estimation of Mineral Resources and that the sample density allows for a reliable estimate to be made of the size, tonnage and grade of the mineralization in accordance with the level of confidence established by the Mineral Resource categories in the CIM Definition Standards.

1.7. Mineral Resource Estimate

The MRE for the Windfall deposit was prepared by Osisko and reviewed and approved by the QP. The MRE is effective as of June 7, 2022. The MRE follows the November 29, 2019 “CIM Estimation of Mineral Resources and Mineral Reserves Best Practice Guidelines”.

The drill hole database considered for the resource estimate contains 4,834 surface and underground diamond drill holes totalling 1,852,861 m of drilling, of which 4,152 drill holes (1,665,282 m) were completed and assayed by Osisko.



This MRE is constrained by 579 mineralization envelopes that were modelled in Leapfrog Geo software from hand selected assays using a minimum true thickness of 2.0 m. Equal-length composites of 2.0 m were calculated inside the mineralized lenses. A three-step capping strategy was applied to the composites before the grade interpolation to limit the influence of high-grade composites over long distances. The search ellipsoid ranges were defined from variography studies, which also determined the parameters for the Ordinary Kriging (“OK”)-based gold interpolations. Gold estimation parameters were used for the silver estimations. The Inverse Distance Square (“ID2”) method was used for the estimation of the silver.

The block models were generated in Datamine Studio RM software using parent cell sizes of 5 m EW, 2 m NS and 5 m height, and sub-blocked to minimum sub-cell sizes of 1.25 m EW, 0.5 m NS and 1.25 m height.

The blocks were assigned to resource categories, or excluded from the resource, based on a series of clipping boundaries delineating areas of blocks with similar confidence levels. Measured resources were defined in areas where: 1) drill hole spacing is less than 12.5 m; 2) blocks are, for the most part, informed by four drill holes; 3) geological evidence is sufficient to confirm geological and grade continuity; and 4) lenses have been accessed by underground workings. Indicated resources were defined in areas where: 1) the drill hole spacing is less than 25 m; 2) blocks are, for the most part, informed by three drill holes; and 3) geological evidence is sufficient to assume geological and grade continuity. Inferred resources were defined from areas where: 1) drill hole spacing is less than 100 m; 2) blocks are informed by a minimum of two drill holes; and 3) geological evidence is sufficient to imply, but not verify geological and grade continuity.

The Mineral Resource estimation is not solely based on the application of a cut-off grade. Isolated and discontinuous blocks above the cut-off grade (3.5 g/t Au) were excluded from the MRE. Additionally, “must-take” material, i.e., isolated blocks below cut-off grade located within a potentially mineable volume, were included in the MRE.

Table 1-2 presents the updated Mineral Resource estimation for the Windfall Project.



Table 1-2: Windfall gold deposit Measured, Indicated, and Inferred Mineral Resources (by area)

Area	Measured					Indicated					Inferred				
	Tonnes ⁽¹⁾ (000 t)	Grade Au (g/t)	Grade Ag (g/t)	Ounces Au ⁽¹⁾ (000 oz)	Ounces Ag ⁽¹⁾ (000 oz)	Tonnes ⁽¹⁾ (000 t)	Grade Au (g/t)	Grade Ag (g/t)	Ounces Au ⁽¹⁾ (000 oz)	Ounces Ag ⁽¹⁾ (000 oz)	Tonnes ⁽¹⁾ (000 t)	Grade Au (g/t)	Grade Ag (g/t)	Ounces Au ⁽¹⁾ (000 oz)	Ounces Ag ⁽¹⁾ (000 oz)
Lynx ⁽²⁾	671	11.4	7.2	247	154	6,638	13.2	6.7	2,814	1,426	4,774	10.8	6.9	1,663	1,063
Underdog	–	–	–	–	–	928	9.5	3.4	284	101	4,072	7.7	3.0	1,011	397
Main ⁽³⁾	109	9.4	4.4	33	16	2,685	7.6	4.8	655	412	2,799	5.8	3.3	518	296
Triple 8	–	–	–	–	–	–	–	–	–	–	642	7.0	6.6	145	136
Total in situ	780	11.1	6.8	279	170	10,250	11.4	5.9	3,754	1,939	12,287	8.4	4.8	3,337	1,892
Stockpiles	32	16.9	4.3	17	4	–	–	–	–	–	–	–	–	–	–
Total	811	11.4	6.7	297	174	10,250	11.4	5.9	3,754	1,939	12,287	8.4	4.8	3,337	1,892

Notes:

(1) Values are rounded to nearest thousand which may cause apparent discrepancies.

(2) Lynx area includes: Lynx Main, Lynx HW, Lynx SW, Lynx 4, and Triple Lynx.

(3) Main area includes: Zone 27, Caribou 1, Caribou 2, Caribou Extension, Bobcat, Mallard, Windfall North, and F-Zones.

- The independent qualified person for the 2022 MRE, as defined by NI 43-101 guidelines, is Pierre-Luc Richard, P. Geo. (OGQ#11119), of PLR Resources Inc. The effective date of the estimate is June 7, 2022.
- The Windfall Mineral Resource estimate follows the November 29, 2019, CIM Estimation of Mineral Resources and Mineral Reserves Best Practice Guidelines.
- These Mineral Resources are not Mineral Reserves as they have not demonstrated economic viability. The quantity and grade of reported Inferred Mineral Resources in this news release are uncertain in nature and there has been insufficient exploration to define these resources as Indicated or Measured; however, it is reasonably expected that the majority of Inferred Mineral Resources could be upgraded to Indicated Mineral Resources with continued exploration. Resources are presented undiluted and in situ and are considered to have reasonable prospects for economic extraction. Isolated and discontinuous blocks above the stated cut-off grade are excluded from the Mineral Resource estimate. Must-take material, i.e., isolated blocks below cut-off grade located within a potentially mineable volume, was included in the Mineral Resource estimate.
- As of June 7, 2022, the database comprises a total of 4,834 drill holes for 1,852,861 m of drilling in the area extent of the Mineral Resource estimate, of which 4,152 drill holes (1,665,282 m) were completed and assayed by Osisko. The drill hole grid spacing is approximately 12.5 m x 12.5 m for definition drilling, 25 m x 25 m for infill drilling and larger for extension drilling.
- All core assays reported by Osisko were obtained by analytical methods described below under "Quality Control and Reporting Protocols".



6. Geological interpretation of the deposit is based on lithologies, mineralization style, alteration, and structural features. Most mineralization envelopes are subvertical, striking NE-SW and plunging approximately 40 degrees towards the North-East. The 3D wireframing was generated in Leapfrog Geo, a modelling software, from hand selections of mineralization intervals. The Mineral Resource estimate includes a total of 579 tabular, mostly sub-vertical domains defined by individual wireframes with a minimum true thickness of 2.0 m.
7. Assays were composited within the mineralization domains into 2.0 m length composites. A value of 0.00125 g/t Au and 0.0025 g/t Ag ($\frac{1}{4}$ of the detection limit) was applied to unassayed core intervals.
8. High-grade composites were capped. Capping was determined in each zone from statistical studies on groups of lenses sharing similar mineralization characteristics. Capping varies from 6 g/t Au to 200 g/t Au and from 5 g/t Ag to 150 g/t Ag. A three-pass capping strategy defined by capping values decreasing as interpolation search distances increase was used in the grade estimations.
9. Block models were produced using Datamine Studio RM Software. The models are defined by parent cell sizes of 5 m EW, 2 m NS and 5 m height, and sub-blocked to minimum sub-cell sizes of 1.25 m EW, 0.5 m NS and 1.25 m height.
10. Ordinary Kriging (OK) based interpolations were produced for gold estimations in each zone of the Windfall deposit, while silver grade estimations were produced using Inverse Distance Squared (ID2) interpolations. Gold estimation parameters are based on composite variography analyses. The gold estimation parameters were used for the silver estimation.
11. Density values between 2.74 and 2.93 were applied to the mineralized lenses.
12. The Windfall Mineral Resource estimate is categorized as Measured, Indicated, and Inferred Mineral Resource as follows:
 - The Measured Mineral Resource category is manually defined and encloses areas where:
 - I. drill spacing is less than 12.5 m;
 - II. blocks are informed by mostly four drill holes;
 - III. geological evidence is sufficient to confirm geological and grade continuity;
 - IV. lenses have generally been accessed by underground workings.
 - The Indicated Mineral Resource category is manually defined and encloses areas where:
 - I. drill spacing is generally less than 25 m;
 - II. blocks are informed by mostly three drill holes;
 - III. geological evidence is sufficient to assume geological and grade continuity.
 - The Inferred Mineral Resource category is manually defined and encloses areas where:
 - I. drill spacing is less than 100 m;
 - II. blocks are informed by a minimum of two drill holes;
 - III. geological evidence is sufficient to imply, but not verify geological and grade continuity.



13. Tonnage and gold grade of the stockpiles were estimated using the grade control model. Densities by lithologies, ranging from 2.76 to 2.84, were used in the estimation of the tonnages. Gold grades were estimated with an average of muck samples results for every round tonnage, based on muck samples with an average sample weight of 3.4 kg taken every 8-yard scoop bucket. The sampling capping varying between 60 g/t Au to 80 g/t Au were applied on the muck gold grade results. An average per silver grade estimates in the stockpiles were reported from the resource block model as silver was not analyzed in the muck samples.
14. The Mineral Resource is reported at 3.5 g/t Au cut-off. The cut-off grade is based on the following economic parameters: gold price at 1,600 USD/oz, exchange rate at 1.28 USD/CAD, 93% mill recovery; payability of 99.95%; selling cost at 5 USD/oz, 2% NSR royalties, mining cost at 125 CAD/t milled, G&A cost at 39 CAD/t milled, processing cost at 42 CAD/t, and environment cost at 4 CAD/t.
15. Estimates use metric units (metres (m), tonnes (t), and g/t). Metal contents are presented in troy ounces (metric tonne x grade / 31.103475).
16. The independent qualified person is not aware of any known environmental, permitting, legal, title-related, taxation, socio-political or marketing issues, or any other relevant issue that could materially affect the Mineral Resource estimate.



1.8. Mineral Reserve Estimate

The Mineral Reserves outlined in this report are based on Measured and Indicated Mineral Resources, and do not include any Inferred Mineral Resources. The Mineral Reserves follow NI 43-101 requirements and the November 29, 2019 "CIM Estimation of Mineral Resources and Mineral Reserves Best Practice Guidelines".

The total Proven and Probable Mineral Reserves at Windfall are estimated at 12.2 million tonnes at 8.06 g/t Au for 3.16 million ounces of gold, and grading 4.18 g/t Ag for 1.64 million ounces of silver.

Factors that may affect the Mineral Reserve estimates include: adjustments to gold price and exchange rate assumptions; changes in operating and capital cost estimates; dilution adjustments; changes to hydrogeological and underground dewatering assumptions; ability to permit the Windfall Project; and changes to modifying factor assumptions, including environmental, permitting and social licence to operate.

There is upside potential for the estimates if mineralization that is currently classified as Inferred Mineral Resources, which is contained within Mineral Reserve mining blocks and is being milled as 0 g/t dilution, is converted to Mineral Reserves following further definition drilling not currently included in the study.

The resulting Mineral Reserve estimate is shown in Table 1-3.



Table 1-3: Windfall gold deposit Mineral Reserves

Area	Probable				
	Tonnes (000 t)	Grade Au (g/t)	Grade Ag (g/t)	Ounces Au (000 oz)	Ounces Ag (000 oz)
Lynx ⁽¹⁾	8,882	8.83	4.58	2,523	1,307
Underdog	906	6.80	2.31	198	67
Main ⁽²⁾	2,363	5.55	3.44	422	261
Total in situ	12,151	8.04	4.19	3,143	1,635
Stockpiles	33	15.24	3.74	16	4
Total	12,183	8.06	4.18	3,159	1,639

Notes:

⁽¹⁾ Lynx area includes: Lynx Main, Lynx HW, Lynx SW, Lynx 4, and Triple Lynx.

⁽²⁾ Main area includes: Zone 27, Caribou 1, Caribou 2, Caribou Extension, Bobcat, Mallard, Windfall North, and F-Zones.

1. The independent qualified person for the 2022 MRE, as defined by NI 43-101 guidelines, is Patrick Langlais, P. Eng. (OIQ#6021556), of Entech Mining Ltd. The effective date of the estimate is November 25, 2022.
2. The Windfall Mineral Reserve Estimate follows the May 19, 2014 "CIM Definition Standards - For Mineral Resources and Mineral Reserves" and the November 29, 2019 "CIM Estimation of Mineral Resources and Mineral Reserves Best Practice Guidelines".
3. These Mineral Reserves have been diluted based on geotechnical recommendations and have had a mining recovery applied.
4. Values are rounded to nearest thousand, which may result in apparent discrepancies.
5. The Mineral Reserve is depleted for all mining to November 3, 2022.
6. The Mineral Reserve is reported using a 3.5-g/t break-even, a 2.5-g/t stope incremental, and a 1.7-g/t marginal cut-off grade.
7. All Measured Mineral Resources have been classified as Probable Mineral Reserve.
8. Stockpile values were provided by Osisko and account for less than 0.1% of Mineral Reserve ounces.
9. Estimates use metric units (metres (m), tonnes (t), and g/t). Metal contents are presented in troy ounces (metric tonne x grade / 31.103475).
10. The independent qualified person is not aware of any known environmental, permitting, legal, title-related, taxation, socio-political or marketing issues, or any other relevant issue that could materially affect the Mineral Reserve Estimate.



1.9. Mining Methods

The Mineral Reserves used in the mine plan are contained over a strike length of 2,300 metres to a depth of approximately 1,100 metres. Each zone is characterized by multiple veins, which mainly trend ENE and have a vertical to subvertical plunge. The lithology units across the different mining zones are generally brittle, strong and hard rock masses, sparsely jointed to blocky. The volcanic rocks exhibit various intensities of foliation, but the foliation is generally strong. The rock mass quality becomes significantly lower inside the boundaries of, and in proximity to, the interpreted faults.

The Windfall Project mineralization varies in dip and thickness both along strike and at depth. All geometries are suitably extracted using the Longitudinal Longhole Stoping method with backfill.

The underground mine plan targets a production rate of 3,400 tpd. Stope dimensions are 20 metres in height, median of 25 metres in strike length, and have a median thickness of 4.4 m with a minimum thickness of 3.0 m. Ore will be extracted using a fleet of 14 and 18 tonne load-haul-dump machines ("LHDs") and 54 tonne haul trucks using a ramp to surface.

The pre-production of Windfall deposit will start in Q2-2024 and production will finish during Year 2035.

1.10. Mineral Processing and Metallurgical Testing

Metallurgical testwork was conducted using material from various zones within the Windfall deposit including: Main (Zone 27 and Caribou), Lynx, Triple Lynx, Lynx 4 and Underdog. Representative samples were selected considering different rock types, precious metal grades and special location (depth and spatial distribution) within the deposit. The projected metallurgical recovery was established using the results of gravity recovery testwork followed by leaching testwork on composites from the various zones.

Several extended gravity recoverable gold ("E-GRG") tests were performed on each of the zones to obtain a more reliable idea of the gravity recoverable gold ("GRG").

Leaching optimization test works have been performed to improve the flowsheet. These testworks realized on the same samples have given similar results as variability testworks. Metallurgical testwork to date has confirmed that good precious metal recoveries can be achieved using a conventional process consisting of crushing and grinding to 37 μm (P_{80}), with gravity recovery followed by whole ore leaching (36 hrs) of the gravity tailings.

Filtration and paste backfill testing programs were carried out by Pocock Industrial Ltd., Paterson & Cooke and Golder on projected Windfall detoxified tailings. The results show the amenability of producing paste backfill and dry stack for specific design criteria.



- The desired tailings solids concentration for dry stacking (84% w/w) can be achieved using pressure filtration;
- A paste recipe made with 3.11% of 90/10 binder reaches a UCS of 175 kPa after a curing time of 14 days (as required by the mine plan).

1.10.1. Process Flowsheet

Based on the testwork conducted, the process flowsheet consists of primary crushing, followed by a grinding circuit consisting of a SAG mill (in close circuit with a pebble crusher) and ball mill (in close circuit with cyclones – SABC circuit). A gravity circuit followed by intensive leaching recovers coarse gold from the cyclone underflow, while the cyclone overflow is treated in a carbon-in-pulp circuit. Gold is recovered in an ADR (Adsorption-Desorption-Reactivation) circuit followed by electrowinning (“EW”) cells.

The tailings filtration plant is located less than 1km southeast from the Windfall process plant building. The plant consists of pressure filters and their ancillaries, paste mixers, paste pumps, a clarifier, a binder storage and dosing system and a dry stack storage facility. The totality of the process tailings is filtered. Based on the mine plan, approximately 39% of the tailings are transformed in paste backfill. The remaining tailings are disposed of as dry stack.

1.10.2. Metal Recovery Projections

Based on the proposed flowsheet, the overall projected metallurgical recovery values for gold and silver from the Windfall deposit are presented in Table 1-4.



Table 1-4: Projected metallurgical recoveries values for Au and Ag

Composite	Gravity				Leach (Gravity tails)				Overall	Overall
	Au distribution (%)	Ag distribution (%)	Au recovery (%)	Ag recovery (%)	Au distribution (%)	Ag distribution (%)	Au recovery (%)	Ag recovery (%)	Au recovery (%)	Ag recovery (%)
Main	33	21	31.9	20.6	68	79	90.0	76.1	93.2	81.1
Lynx	37	23	36.3	23.0	64	77	92.8	77.7	95.4	82.9
Triple Lynx	33	31	32.7	30.6	67	69	89.4	76.8	92.9	83.9
Lynx 4	26	18	25.2	17.5	75	82	88.9	82.6	91.7	85.6
Underdog	37	27	36.3	26.7	64	73	93.3	73.2	95.8	80.4



The Windfall Project considers the following buildings and site infrastructure as existing:

- Windfall Site access road;
- Main zone portal with underground mine services (compressed air, electricity, ventilation intake);
- Waste rock stockpile;
- Surface water management ditches, ponds, and pumping stations;
- Water treatment plants;
- Exhaust raise and fan;
- Hybrid secondary WAN link (fibre optic and microwave radio);
- Light structure, fabric-covered domes;
- Meteorological station;
- Borrow pit;
- Diesel generators;
- Telecommunication tower and private LTE system for the surface and underground mine.

The following elements are considered separate from the Project, as they are led by subsidiaries of the Cree First Nation of Waswanipi ("CFNW"), the main one being Miyuukaa. CFNW will be responsible for constructing and supplying the following infrastructure components:

- MICO step-up substation (25 kV to 69 kV) to interconnect with Hydro-Québec Waswanipi substation;
- 69 kV overhead transmission power line and MICO substations;
- Windfall step-down substation (69 kV to 13.8 kV) located in the vicinity of the Windfall Project;
- Fiber optic WAN link to Waswanipi as optical ground wire ("OPGW").

The following existing infrastructure is considered outside the scope of the Feasibility Study, but remains in use for exploration:

- 300-person capacity exploration camp complex, including potable water and sewage systems;
- Helipad;
- Core logging buildings;
- Storage domes;
- Overhead power lines and camp area genset.



The Project will require new key infrastructure as follows:

- Process plant complex including crushing line, offices, dry and warehouse;
- Tailings filtration and paste backfill plant;
- Camp complex including dormitories, cafeteria and dining room, fitness and game centre, welcome centre, and laundry facilities;
- First Nations cultural centre;
- Potable water and sewage management systems;
- Gatehouse;
- Truck shop;
- Production core shack building that will also house the emergency vehicles;
- Extension of the existing waste rock stockpile;
- Overburden stockpile;
- Ore stockpile;
- Tailings storage facility;
- Surface water management facilities, including ditches, ponds, pumping stations, and piping;
- Site service and hauling roads;
- Borrow pits;
- Materials laydown and storage area;
- Domestic waste management storage area;
- Lynx Zone portal with underground mine services (electricity, ventilation intake, fuel distribution);
- Exhaust raises and fans;
- Fire protection water storage, pumping stations, and distribution systems;
- Diesel, gasoline and propane storage and distribution systems;
- Upgrades to the existing water treatment plant;
- Overhead 13.8 kV power lines;
- An additional telecommunication tower;
- A local integrated operations centre;
- Regional administration offices and warehousing (locations not yet determined).



1.11.1. Tailings Management Facility

Around 60 % of the tailings generated from ore processing will be filtered and directed to a surface tailings management facility ("TMF") as a stack located northeast of the filtering plant while the remaining will be returned underground as a paste backfill material. Sludge from underground water decantation system will be mixed with the tailings surface stream prior to filtering. The tailings will be hauled by trucks and compacted in a controlled manner in the dry stack tailings. It should be noted that the terminology "dry stack" refers to the concept of the structure and is not related to the water content of the filtered tailings in the stack. No water will be allowed to pond within the TMF. To avoid water accumulation within the stack, a drainage system will be constructed in the TMF to evacuate rainwater and seepage from the placed tailings.

Geochemical characterization indicates that the tailings are potentially generating, leachable for metals and cyanide-bearing. Thus, the design of the TMF includes a geosynthetic liner as a measure to limit pore water seepage to groundwater.

Runoff and seepage contact water will be collected by a network of ditches surrounding the TMF. Contact water will be directed to the two water storage basins in the vicinity of the TMF.

1.11.2. Water Management Infrastructure

The water management strategy encourages the use of the existing infrastructure and diversion of clean water around the site. Contact water (i.e., water that has been in contact with mine facilities such as the Waste Rock Stockpile ("WRS"), the Ore Stockpile, the Tailings Management Facility ("TMF") or the industrial zone) will be collected and directed into ponds through a system of drainage ditches and pumps. Twelve ponds will be required to ensure the collection of all the contact water runoff, including the currently existing collection pond and the three ponds that will be constructed for the bulk sample. Contact water will be conveyed to the water treatment plant ("WTP") for appropriate treatment to ensure water quality requirements are met before its reuse or its discharge to the environment.

1.11.3. Waste Rock, Ore and Overburden Storage

The WRS will be lined because a portion of the waste rock is expected to be acid generating and metal leaching. The lined WRS design capacity is 9.11 Mt. The volume of waste rock that will be used for construction purposes and that will need to be returned to the stockpiles during closure has been considered to ensure the WRS maximal capacity is not reached. Several phases of expansion have been planned, the last one being in 2030. Perimeter ditches will collect any contact water.



The ore stockpile will be lined because the ore is expected to be acid generating and metal leaching. The lined ore stockpile will have a capacity of 157,750 t and is planned to be located next to the crushing plant. A perimeter drainage ditch that encircles the crusher pad is designed to collect the runoff water.

The topsoil to be stored and managed at the Windfall site comes mainly from the site preparation required for the construction of the TMF, the process plant, as well as the stockpiles, ditches and ponds. The identified site for the overburden stockpile can accommodate 638,100 m³. The overburden stockpile will not be lined with a geomembrane, but runoff water will be collected by perimeter ditches and directed to a sedimentation pond before it is treated and released to the environment.

1.12. Environmental and Permitting

The Windfall Project is subject to the provincial Northern EIA procedure. The environmental impact assessment ("EIA") currently in progress will be completed and submitted.

Current project definition provides a basis upon which most anticipated environmental and social impacts can be identified. No specific inordinate environmental risk to project development was identified. Although there are some environmental and social sensitive elements, optimization could be made to eliminate or reduce the effect on these components. Consultation and engagement activities with local and First Nations communities may highlight additional issues and mitigation approaches.

Discussion with First Nations representatives has been initiated in order to establish a Social and Economic Participation Agreement (an impact and benefit agreement, or "IBA").

Finally, the closure costs are estimated at \$83.3M, including direct and indirect costs (and an 18% contingency).

1.13. Market Studies and Contracts

Gold and silver are freely traded precious metal commodities on the world market, for which there is a steady demand from numerous buyers. The markets for gold and silver are global in nature and is unlikely to be affected by production from the Project. Limited effort is expected to be required to develop the doré marketing strategy.

This Feasibility Study assumes a long-term USD/CAD exchange rate of 0.77:1.00, a gold price of USD1,600/oz and a silver price of USD21.00/oz to support the base case economic analysis as summarized in Chapter 22. The CAD/USD exchange rate and metal prices were established by Osisko based on consensus pricing derived from bank analysts' long-term forecasts (November 2022), historical metal price averages and prices used in recent publicly disclosed comparable studies that were deemed to be credible.



There are no refining agreements or sales contracts currently in place for the Project that are relevant to this technical report.

1.14. Capital and Operating Costs Estimates

The total pre-production capital cost for the Windfall Project is estimated to be \$788.6M (including contingencies and indirect costs). The total does not include a total of \$146.5M for:

- Sunk costs spent prior to the FS for the purchase of the process plant grinding mills (\$5.6M) and the environmental impact study (\$1.1M);
- Long lead item expenses planned before start of construction, including engineering studies (\$33.3M), logistics and warehousing (\$2.1M), mechanical and electrical packages (\$57.0M), camp (\$32.2M), material opportunity purchase (\$8M), mining fixed equipment (\$2.9M) and contingency (\$3.0M).

The cumulative life of mine capital expenditure including costs for pre-production, sustaining, site reclamation and closure and salvage value is estimated to be \$1.4B.

The overall capital cost estimate developed in this study meets the AACE Class 3 requirements and has an accuracy range of -10% and +15%. Items such as sales taxes, permitting, licensing, and financing costs are not included in the cost estimate. The Project capital cost summary is outlined in Table 1-5.

Table 1-5: Project capital cost summary¹

Capital Costs (C\$M)	Pre-Production	Sustaining	Total
Mining	80.2	556.7	636.9
Mineral Processing and Filtration Plant	273.8	0.0	273.8
Mine Surface Facilities	0.0	3.7	3.7
Electrical and Communication	14.7	0.0	14.7
Plant Surface Facilities	63.9	0.0	63.9
Waste, Water and Tailings Management	69.5	26.0	95.5
Indirect and Owner's Costs	237.0	1.3	238.3
Site Closure	0.0	83.3	83.3
Salvage Costs	0.0	(18.7)	(18.7)
Subtotal	739.1	652.3	1,391.3
Contingency (P50)	49.5	0.0	49.5
Total Capital Costs	788.6	652.3	1,440.8

1- Capital costs do not include sunk costs and long lead expenses totalling \$146.5M.



The average operating cost over the 10-year mine life is estimated to be \$176.67/t milled or \$726/oz (CAD). Table 1-6, below, provides the breakdown of the projected operating costs for the Windfall Project.

Table 1-6: Project operating cost summary

Cost area	LOM (\$M)	Average annual cost (\$M)	Average (\$/tonne milled)	Average LOM (\$/oz)
Mining	993.0	99.3	82.21	337.7
Process plant including filtration	492.0	49.2	40.76	167.4
Waste and, water management	76.0	7.6	6.30	25.9
General and administration	396.0	39.6	32.81	134.8
Electrical transmission line lease cost	176.0	17.6	14.59	59.9
Total	2,134.0	213.4	176.67	725.6

It is anticipated that an average of 500 employees (staff and labour) will be required for operations.

1.15. Project Economics

The economic/financial assessment of the Windfall Project was carried out using a discounted cash flow approach on a pre-tax and after-tax basis, based on Q4-2022 metal price projections in U.S. currency and cost estimates (CAPEX and OPEX) in Canadian currency. Inflation or cost escalation factors were not taken into account. An exchange rate of USD 0.77 for CAD 1.00 has been assumed over the life of the Project. The base case gold and silver prices are 1,600 USD/oz., and 21.00 USD/oz. respectively. Project economics were evaluated based on a forecast date to receive the construction permit in Q1 2024.

The cumulative cash flow for the Project (after-tax) is \$1,710.2 million over the planned mine life of 10 years. Over the LOM, approximately 2.94 Moz Au, and 1.37 Moz Ag will be produced on a payable basis.

Over the life of the Project, it is estimated that approximately \$127M in royalties and \$0.72B in income and mining tax payments will be paid.

The pre-tax base case financial model resulted in an IRR of 40.1% and an NPV of \$1,685 M using a 5% discount rate. The pre-tax payback period is 2.0 years after the start of production.



On an after-tax basis, the base case financial model resulted in an IRR of 33.8 % and an NPV of \$1,168.4 M using a 5% discount rate. The after-tax payback period is 2.0 years after the start of production.

The LOM operating cash cost per ounce (including by-product credits) is 587 USD/oz Au. The LOM cost all-in sustaining cost ("AISC") per ounce is 758 USD/oz Au derived from the total cash costs plus sustaining capital, closure costs and salvage value. The operating margin over the LOM has been estimated to be 1,013 USD/oz Au based on a gold price of 1,600 USD/oz.

1.16. Project Schedule and Organization

The execution of the Windfall Project will be directly managed by the Osisko Construction Management Team ("CMT"). The engineering and construction works will be contracted out to qualified firms and contractors under the direct supervision of Osisko. Procurement and project control functions such as scheduling, cost control, site logistic and site supervision will be executed directly by Osisko personnel. Due to the complexity of major process equipment transportation, Osisko will retain the services of a specialized company in international logistics services.

An analysis of the detailed Project construction schedule allowed for the development of a preliminary workforce distribution based on a 10-hour work day and a 14 day on-site/7 off-site work schedule. The mine development and operation headcount includes contractor support for the Project development and operation. The preliminary on-site workforce requirement is expected to peak at approximately 1,080 individuals during the construction phase (January 2025). The total estimated workforce accounts for the development of the underground mine, direct and indirect construction labour, along with commissioning crews.

The major Project activity milestones are presented in Table 1-7. Pending the completion of all studies and receipt of the required permits, the process plant construction is scheduled to begin in Q2 2024 with process plant commissioning to begin in Q3 2025.



Table 1-7: Key milestones

Activity	Start Date	Completion Date
Feasibility Study		Q1 2023
Environmental Impact Assessment ("EIA") Submittal		H1 2023
Detailed Engineering	Q4 2022	Q2 2024
Permit for Project Construction		Q2 2024
Process Plant Construction	Q2-2024	Q3 2025
Mine Development Start	Q2 2024	
Process Plant Commissioning	Q3 2025	

1.17. Interpretations and Conclusions

This FS was prepared by a group of independent QPs to demonstrate the economic viability of developing the Windfall resources as an underground mine and processing the ore using a conventional Gravity/CIP circuit in a centrally located process plant. This report provides a summary of the results and findings from each major area of investigation. Standard industry practices, equipment and processes were used. To date, the QPs are not aware of any unusual or significant risks or uncertainties that could materially affect the reliability or confidence in the Windfall Project based on the information available.

The total Proven and Probable Mineral Reserves at Windfall are estimated at 12.2 million tonnes at 8.06 g/t Au for 3.16 million ounces of gold and grading 4.18 g/t Ag for 1.64 million ounces of silver.

The results of the Study indicate that the proposed Project has technical and financial merit using the assumptions as outlined in this technical report. It has also identified additional field work, metallurgical testwork, trade-off studies and analysis required to support more advanced mining studies. The QPs consider the FS results sufficiently reliable and recommend that the Windfall Project be advanced to the next stage of development through the initiation of detailed engineering.

1.17.1. Risks and Opportunities

An analysis of the results of the investigations has identified a series of risks and opportunities associated with each of the technical aspects considered for the development of the Windfall Project.



1.17.1.1. Primary Project Risks

The most significant potential risks associated with the Project are:

- Electrical line construction schedule delay (led, owned and built by a subsidiary of the CFNW) delivery: This will result in challenges for the mining development team in meeting project timelines.
- Delay in permit authorization: This would delay the start of project construction which would delay revenues and increased capital costs due to more construction activities being performed during the winter period.
- Construction union contract negotiations: The current provincial collective construction labour agreement with the Association de la construction du Québec ("ACQ") ends in 2025. Negotiations and final labour agreement contract terms may result in construction delays and higher project capital costs.
- Labour availability: Shortage of qualified workers during construction and operations may result in higher costs, inefficiencies and schedule delays.
- New technology risks: The application of newer technologies may not result in the anticipated benefits resulting in downtime or increased costs.
- Geological resources: Gold grades and distribution could vary due to the observed nugget effect. The variable geometry of the dikes, structural features and mineralized zones is also complex to model. The locations of mineralized zones could be off slightly with variable shapes locally. There is a certain risk that gold grades and actual resource tonnages are lower than estimated resulting in lower gold recoveries and higher operating costs.

Many of the previously noted risks are common to most mining projects, many of which may be mitigated, at least to some degree, with adequate engineering, planning and pro-active management.

1.17.1.2. Primary Project Opportunities

There are numerous opportunities that could improve the economics, timing and/or permitting potential of the Project. The key opportunities that have been identified at this time are as follows:

- Site water management: The current site water model can be improved based on additional sampling data to confirm water management design criteria. This could potentially result in smaller site water management infrastructure as well as reduced water treatment operating costs and impacts.
- Construction materials: There is an opportunity to reduce off-site procurement of construction materials such as aggregate and clean fill by sourcing it from the Project site. Additional testing of material to be potentially excavated during the construction phase may result in an opportunity to optimize the overall construction material requirements and reduce construction costs.



- Pre-fabricated buildings and modules: There is an opportunity to have some project components and buildings pre-fabricated or modularized off-site. This could result in reduced on-site construction costs and provide benefits for the schedule.
- Geological resources: Due to the variability of the deposit (gold grade, distribution and geometry) there is an opportunity to update the resource estimate with additional data collected based on future work. A 4th bulk sample is planned to be extracted and this may provide additional information which could lead to higher gold grades and additional tonnes.
- The geological resource contains approximately 1.3 million tonnes of Inferred mineral resources which cannot be included within the project's Mineral Reserves. There is an opportunity to convert these inferred resources to indicated resources through additional underground drilling.
- Government sustainability programs: The Canadian and Québec governments are developing programs to provide incentives for manufacturers and mining companies to implement new technologies and approaches to reduce their energy consumption and the impact of their operations on the environment. Aligned with Osisko Mining's sustainability approach, there is the potential that the Windfall Project might qualify for some of these governmental programs which could result in lower costs and an improved environmental footprint.
- Process plant and Infrastructure Design: With additional testwork, trade-off studies and engineering design effort, there is the potential to simplify and optimize the layout of the process plant and other Project infrastructure. This could result in lower costs, shorter construction timelines and operational efficiency improvements. Based on bulk sample results from Windfall, additional gold recovery could be achieved by optimizing the gravity circuit.

1.18. Recommendations

The QPs recommend that the Project be advanced towards the detailed engineering and procurement stage. It is also recommended that environmental and permitting continue as needed to support Osisko's development plans and Project schedule. Additional work, including conversion drilling is warranted. A 4th bulk sample is planned (subjected to permit approval) to help confirm resource grades and tonnage. A budget of approximately \$314.8M (including \$10.1M in contingency) is proposed for drilling, detailed engineering and camp, equipment and material purchases in 2023 through to Q1-2024. Table 1-8 presents the estimated costs for the planned work program. Additional details are presented in Chapter 26.



Table 1-8: Work program budget

Work related to Exploration	Budget	
	Description	Cost (\$M)
Underground Definition Drilling	140,000 m	24.5
Conversion Drilling	30,000 m	5.3
Exploration Drilling	20,000 m	5.0
Fourth Bulk sample development UG	-	97.9
Fourth Bulk sample development Surface	-	35.3
Contingency	-	7.1
Work related to exploration subtotal	190,000 m	175.0
Long lead items and detailed engineering	Budget	
	Description	Cost (\$M)
Environmental Impact Assessment (EIA)	-	1.3
Detailed Engineering	-	33.3
Camp Purchase	-	32.2
Material Opportunity Purchase	-	8.0
Mechanical & Electrical Package Lists	-	57.0
Logistics & Warehousing	-	2.1
Mining Fixed Equipment Purchase	-	2.9
Contingency	-	3.0
Long lead items subtotal	-	139.8
Total	-	314.8

Colin Hardie, QP, finds the recommendations and budgets to be reasonable and justified based on the studies and observations made to date. It is recommended that Osisko conducts the planned activities subject to funding availability and any other matters that may cause the objectives to be altered in the normal course of Project development.



2. Introduction

This report was prepared and compiled by BBA Inc. ("BBA") at the request of Osisko Mining Inc. ("Osisko"). The purpose of this report is to summarize the results of the Feasibility Study ("FS") of the Windfall deposit in accordance with the guidelines of the Canadian Securities Administrators National Instrument 43-101 and Form 43-101F1.

BBA is an independent engineering consulting firm headquartered in Mont-Saint-Hilaire, Québec with the mining group based in downtown Montréal, Québec. This report was prepared with contributions from Osisko as well as Andrieux & Associates Geomechanics Consulting LP ("A2GC"), Entech Mining Ltd. ("Entech"), GCM Consultants Inc. ("GCM"), PLR Resources Inc. ("PLR"), WSP Canada Inc. ("WSP"), and Golder Associates Ltd ("Golder").

The property is located in the Eeyou Istchee James Bay ("EIJB") region of central-northwest Québec, Canada.

2.1. Basis of Technical Report

The following report presents the results of the Feasibility Study ("FS") for the development of the Windfall Project. Osisko mandated engineering consulting group BBA in April 2022 to lead and perform the FS, based on contributions from a number of independent consulting firms including A2GC, Entech, GCM, PLR Resources, WSP, and Golder. This report was prepared at the request of Kim-Quyên Nguyễn of Osisko Mining Inc. As of the date of this report, Osisko is a Canadian mineral exploration company trading on the TSX under the trading symbol ("OSK"), with its head office situated at:

155 University Avenue, suite 1440
Toronto, Ontario
M5H 3B7

This report, titled "Feasibility Study for the Windfall Project", was prepared by Qualified Persons ("QPs") following the guidelines of the NI 43-101 and in conformity with the guidelines of the Canadian Institute of Mining, Metallurgy and Petroleum ("CIM") Standards on Mineral Resources and Reserves.



2.2. Report Responsibility and Qualified Persons

The following individuals, by virtue of their education, experience and professional association, are considered QPs as defined in the NI 43-101, and are members in good standing of appropriate professional institutions.

- Patrick Andrieux, P.Eng. A2GC
- Colin Hardie, P.Eng. BBA Inc.
- Mathieu Bélisle, P.Eng. BBA Inc.
- Patrick Langlais, P.Eng. Entech Mining Ltd.
- Mélissa Tremblay, P.Eng. GCM Consultants Inc.
- Pierre-Luc Richard, P.Geo. PLR Resources Inc.
- Yves Boulianne, P.Eng. Golder
- Frédéric Choquet, P.Eng. WSP
- Ken De Vos, P.Geo. Golder
- Aytaç Göksu, P.Eng. Golder
- Andréanne Hamel, P.Eng. WSP
- Isabelle Larouche, P.Eng. WSP
- Éric Poirier, P.Eng., PMP WSP

The preceding QPs have contributed to the writing of this report and have provided QP certificates, included at the beginning of this report. The information contained in the certificates outlines the sections in this report for which each QP is responsible. Each QP has also contributed figures, tables and portions of Chapters 1 (Summary), 2 (Introduction), 25 (Interpretation and Conclusions), 26 (Recommendations), and 27 (References). Table 2-1 outlines the responsibilities for the various sections of the report and the name of the corresponding Qualified Person.

Table 2-1: Qualified Persons and areas of report responsibility

Chapter	Description	Qualified Person	Company	Comments and exceptions
1.	Executive Summary	C. Hardie	BBA	All QPs contributed based on their respective scope of work and the Chapters/Sections under their responsibility.
2.	Introduction	C. Hardie	BBA	All QPs contributed based on their respective scope of work and the Chapters/Sections under their responsibility.



Chapter	Description	Qualified Person	Company	Comments and exceptions
3.	Reliance on other Experts	C. Hardie	BBA	All Chapter 3
4.	Project Property Description and Location	C. Hardie	BBA	All Chapter 4
5.	Accessibility, Climate, Local Resource, Infrastructure and Physiography	C. Hardie	BBA	Sections 5.1, 5.2, 5.4, 5.5 and 5.6
		A. Göksu	Golder	Section 5.3
6.	History	P.-L. Richard	PLR	All Chapter 6
7.	Geological Setting and Mineralization	P.-L. Richard	PLR	All Chapter 7
8.	Deposit Types	P.-L. Richard	PLR	All Chapter 8
9.	Exploration	P.-L. Richard	PLR	All Chapter 9
10.	Drilling	P.-L. Richard	PLR	All Chapter 10
11.	Sample Preparation, Analyses and Security	P.-L. Richard	PLR	All Chapter 11
12.	Data Verification	P.-L. Richard	PLR	All Chapter 12
13.	Mineral Processing and Metallurgical Testing	M. Bélisle	BBA	Sections 13.1, 13.2, 13.3 and 13.5
		I. Larouche	WSP	Section 13.4
14.	Mineral Resource Estimate	P.-L. Richard	PLR	All Chapter 14
15.	Mineral Reserve Estimate	P. Langlais	Entech	All Chapter 15
16.	Mining Methods	P. Langlais	Entech	Sections 16.1, 16.4 to 16.11
		P. Andrieux	A2GC	Section 16.2
		A. Hamel	WSP	Section 16.3
17.	Recovery Methods	M. Bélisle	BBA	Sections 17.1, 17.2, 17.3 and 17.6
		I. Larouche	WSP	Sections 17.4 and 17.5
18.	Project Infrastructure	E. Poirier	WSP	Sections 18.1 to 18.3, 18.5, 18.7 to 18.17, 18.18.6 and 18.19
		F. Choquet	WSP	Sections 18.4, 18.23.2, 18.24 and 18.25
		Y. Boulianne	Golder	Sections 18.22, co-author for Section 18.4
		A. Göksu	Golder	Sections 18.23 and 18.23.1
		C. Hardie	BBA	Sections 18.6, 18.18 (except Section 18.18.6), 18.20 and 18.21
		M. Tremblay	GCM	Section 18.23.3
19.	Market Studies and Contracts	C. Hardie	BBA	All Chapter 19



Chapter	Description	Qualified Person	Company	Comments and exceptions
20.	Environmental Studies, Permitting, and Social or Community Impact	F. Choquet	WSP	Sections 20.1 (except Sections 20.1.2.2. Hydrogeology and Baseline Groundwater Quality), 20.2.2, 20.2.3, 20.2.6, 20.3, 20.4 and 20.5
		A. Hamel	WSP	Sections 20.1.2.2 Hydrogeology and Baseline Groundwater Quality
		K. De Vos	Golder	Section 20.2.1
		Y. Boulianne	Golder	Section 20.2.4
		A. Göksu	Golder	Section 20.2.5
21.	Capital and Operating Costs	C. Hardie	BBA	Sections 21.1 (except Sections 21.1.3.1.3, 21.1.3.1.4, 21.1.3.1.6 to 21.1.3.1.8 and 21.1.4.1 to 21.1.4.5), 21.2.1, 21.2.2, 21.2.6 and 21.3, and co-author of Section 21.2.5
		P. Langlais	Entech	Sections 21.1.3.1.3, 21.1.4.2 and 21.2.3
		E. Poirier	WSP	Sections 21.1.3.1.4, 21.1.3.1.6, 21.1.3.1.7 Process Plant Earthworks - Area 665, 21.1.4.1, 21.1.4.3
		I. Larouche	WSP	Section 21.2.4.2
		M. Bélisle	BBA	Sections 21.1.3.1.7 (except Process Plant Earthworks - Area 665) and 21.2.4.1
		F. Choquet	WSP	Section 21.1.4.5, co-author for Sections 21.1.3.1.8 and 21.1.4.4
		Y. Boulianne	Golder	Co-author for Sections 21.1.3.1.8 and 21.1.4
		M. Tremblay	GCM	Section 21.2.5.1, co-author for Sections 21.1.3.1.8 and 21.2.5
22.	Economic Analysis	C. Hardie	BBA	Osisko provided metal prices, exchange rates and royalty costs. WSP provided closure costs. Osisko provided project taxes and after-tax cash flows.
23.	Adjacent Properties	P.-L. Richard	PLR	All Chapter 23
24.	Other Relevant Data and Information	C. Hardie	BBA	Schedule and execution plan developed based on inputs from all contributors and Osisko.
25.	Interpretation and Conclusions	C. Hardie	BBA	All QPs contributed based on their respective scope of work and the Chapters/Sections under their responsibility.
26.	Recommendations	C. Hardie	BBA	All QPs contributed based on their respective scope of work and the Chapters/Sections under their responsibility.



Chapter	Description	Qualified Person	Company	Comments and exceptions
27.	References	C. Hardie	BBA	All QPs contributed based on their respective scope of work and the Chapters/Sections under their responsibility.

2.3. Effective Dates and Declaration

This report supports the Osisko press release titled “Osisko Mining Delivers Positive Feasibility Study for Windfall” dated November 28, 2022. The overall effective date of the report is November 25, 2022. The report has a number of cut-off dates for information:

- Effective date of the Windfall Mineral Reserve Estimate is November 25, 2022, and is based on the mineral resource block model dated June 7, 2022;
- Final Feasibility mine plan was provided on November 3, 2022;
- Finalization date of the financial analysis: November 25, 2022.

This report was prepared as National Instrument 43-101 Technical Report for Osisko Mining Inc. by Qualified Persons from the following firms: Andrieux & Associates Geomechanics Consulting LP, BBA Inc., Entech Mining Ltd., GCM Consultants Inc., PLR Resources Inc., WSP Canada inc., and Golder Associates Ltd; collectively the “Report Authors”. The quality of information, conclusions, and estimates contained herein is consistent with the level of effort involved in the Report Authors’ services, based on: i) information available at the time of preparation; ii) data supplied by outside sources; and iii) the assumptions, conditions, and qualifications set forth in this report. This report is intended for use by Osisko subject to the terms and conditions of its respective contracts with the Report Authors. Except for the purposes legislated under Canadian provincial and territorial securities law, any other use of this report by any third party is at the sole risk of that party.

As of the effective date of this report, the QPs are not aware of any known litigation potentially affecting the Project. The QPs did not verify the legality or terms of any underlying agreement(s) that may exist concerning the Project ownership, permits, off-take agreements, license agreements, royalties or other agreement(s) between Osisko and any third parties.

The results of this report are not dependent upon prior agreements concerning the conclusions to be reached, nor are there any undisclosed understandings concerning any future business dealings with Osisko and the QPs. The QPs are being paid a fee for their work in accordance with the normal professional consulting practice.

The opinions contained herein are based on information collected throughout the course of the investigations by the QPs, which in turn reflect various technical and economic conditions at the



time of writing. Given the nature of the mining business, these conditions can change significantly over relatively short periods of time. Consequently, actual results can be significantly more or less favourable.

2.4. Sources of Information

2.4.1. General

This report is based in part on internal company reports, maps, published government reports, company letters and memoranda, and public information, as listed in Chapter 27 "References" of this report. Sections from reports authored by other consultants may have been directly quoted or summarized in this report and are so indicated, where appropriate.

This FS has been completed using available information contained in, but not limited to, the following reports, documents and discussions:

- Technical discussions with Osisko personnel;
- QPs' personal inspection of the Windfall Project site;
- Report of mineralogical, metallurgical and grindability characteristics of the Windfall deposit, conducted by industry recognized metallurgical testing laboratories on behalf of Osisko;
- Windfall Mineral Resource Estimate provided by Osisko effective as of June 7, 2022, and Mineral Reserve Estimate as of November 25, 2022;
- A conceptual process flowsheet developed by BBA based on the specific Project testwork and similar operations;
- Internal and commercially available databases and cost models;
- Various reports covering site hydrology, hydrogeology, geotechnical, and geochemistry;
- Various reports covering site physical and biological environment;
- Internal unpublished reports received from Osisko;
- Additional information from public domain sources.

The QPs have no known reason to believe that any of the information used to prepare this report and evaluate the mineral resources presented herein is invalid or contains misrepresentations. The authors have sourced the information for this report from the collection of documents listed in Chapter 27 (References).



2.4.2. A2CG

The following individuals provided specialist input to Patrick Andrieux, QP:

- Amélie Ouellet (A2GC), for the numerical modelling geomechanical assessments.

These specialists are not considered as QPs for the purposes of this NI 43-101 Report.

2.4.3. BBA

The following individuals provided specialist input to Colin Hardie, QP:

- Osisko and its external advisors have provided an estimate for the Owner's costs and contingencies used in the development of the Project's pre-production capital cost estimate (Chapter 21);
- Osisko provided an estimate for the General & Administration costs and Environmental services/labour costs used in the development of the Project's operating cost estimate (Chapter 21);
- Osisko provided the Windfall site mass balance calculation for gold and silver recovery (Chapters 13 and 22);
- Gilles Léonard (BBA) provided cost estimates and input for the site communications and IT infrastructure (Chapters 18 and 21);
- Jean-Francois Beaulieu, Laura Mottola, Pierre Lapointe, and Michel Serres (BBA) provided cost estimates and inputs for Digital Operations of the Windfall site and the Integrated Operations Centre ("IOC") (Chapters 18 and 21);
- Yves Robitaille (BBA) provided input for the third-party transmission line to site and information related to site power criteria and costs (Chapters 18 and 21);
- Claude Catudal (BBA) and James Alarcon (BBA) provided the industrial standards, norms and factors for the various material, manpower and construction costs used in the development of the process plant capital costs (Chapters 18 and 21);
- Osisko and its external advisors provided input to the Project execution strategy and preliminary milestone schedule (Chapter 24).

The following individuals provided specialist input to Mathieu Bélisle, QP:

- Melanie Turgeon (BBA) and Armita Amini (BBA) provided inputs to the PFDs, and mass and water balance;
- Pascal Cordeau (BBA) and Jean-Philippe Laneville (BBA) provided support for the design of the process plant and the capital costs estimation;



- Osisko and Dominique Lascelles (SGS-Québec City) provided support for the development, analysis and discussions related to the metallurgical testwork program.

These specialists are not considered as QPs for the purposes of this NI 43-101 Report.

2.4.4. Entech

The following individuals provided specialist input to Patrick Langlais, QP:

- Patrick McCann, P. Eng. (Entech), for his contribution and input in the mine design and cost validation;
- David Yergeau P.Eng. (Osisko), for his contribution and input on electricity and networks;
- Blaine Ross (Novus Engineering), for his contribution and input on dewatering;
- Frank Palkovits (Responsible Mining Solutions), for his contribution and input on paste backfill distribution;
- Gilles Leonard, P.Eng. (BBA), for his contribution and input on the underground communication network.

These specialists are not considered as QPs for the purposes of this NI 43-101 Report.

2.4.5. GCM

The following individuals provided specialist input to Mélissa Tremblay, QP:

- Osisko and its external advisors have provided preliminary water balance and water quality data to contribute to the water treatment design criteria;
- Simon Delay Fortier, P.Eng. (GPI Consultants) for his contribution to the water treatment plant design and cost estimation;
- Julien Côté, P.Eng. (GCM) for his contribution to the water treatment plant design and cost estimation;
- Michel Primeau, P.Eng. (GCM) for the water treatment plant layout, piping specification, the mechanical equipment technical review and cost estimation;
- François Sasseville, P.Eng. (GCM) for the water treatment plant electric material cost estimation;
- Guillaume Roger, P.Eng. (GCM) for the water treatment plant instrumentation and control cost estimation;
- Alexandre De Carufel, P.Eng. (GCM) for the water treatment plant structural steel and foundation cost estimation;



- Richard Fallon, P.Eng. (GCM) for his general contribution to water treatment plant cost estimation;
- Jocelyn Landreville, P.Eng. (GCM) for his contribution to the water treatment plant building associated cost estimation.

These specialists are not considered as QPs for the purposes of this NI 43-101 Report.

2.4.6. PLR Resources Inc.

The following individuals provided specialist input to Pierre-Luc Richard, QP:

- Antoine Fecteau, P.Eng. (Osisko), Julien Avard, P.Geo. (Osisko), Pascal Simard, P.Geo. (Osisko), and Brandon Choquette, GIT. (Osisko) for the comprehension of the local and regional geology (Chapter 6);
- Matthias Quefferus, P.Geo. (Osisko) and Frédéric Hamel, P.Eng. (Osisko) for the drillhole database (Chapter 11);
- Charles Gaumond, P.Geo. (Osisko) for the QAQC database (Chapter 11);
- Judith St-Laurent, P.Geo. (Osisko), Séverine Blouin, P.Geo. (Osisko), Karen Chiu, P.Geo. (Osisko), Marie-Ève Lajoie, P.Geo. (Osisko), and Audrey Roussel-Lallier, P.Eng. (Osisko) for the 3D models, block model parameters and mineral resource classification (Chapter 14).

These specialists are not considered as QPs for the purposes of this NI 43-101 Report.

2.4.7. WSP and Golder

The following individuals provided specialist input to Yves Boulianne, QP:

- Nicolas Pépin, P.Eng. (Golder) and Gabrielle Boudrias, P.Eng. (Golder) for the tailings management facility design and sections on the tailings management facility;
- Ramdane Abbacha (Golder), for the cost estimate for the tailings management facility and its water management infrastructure.

The following individuals provided specialist input to Frédéric Choquet, QP:

- Kristina Bondy, P.Eng. (WSP) for the site characterization, the waste rock and overburden stockpiles design, and the various ponds civil design and the related sections;
- Marie-Hélène Brisson, Biol. (WSP) and Émilie Deschênes Dénomme (WSP) for the preparation of the Environmental Studies, Permitting, and Social or Community Impact section;
- Audrey Bédard, P.Eng. (WSP) for the closure concept and cost estimate and the preparation of the related section.



The following individuals provided specialist input to Ken De Vos, QP:

- Elizabeth Walsh, P.Geo. (Golder), for the geochemical assessment and her contribution to the redaction of the geochemical sections;

The following individuals provided specialist input to Aytaç Göksu, QP:

- Kamal Hamai, P.Eng. (WSP) for the water management components of the Study;
- Elsa Sormain, P.Eng. (WSP) for the water management infrastructure design and hydrologic and hydraulic modeling and her contribution to the redaction of the water management sections;
- Nasim Hosseini, P.Eng. (BC) (Golder) for the water balance modeling and her contribution to the redaction of the water balance section.

The following individuals provided specialist input to Andréanne Hamel, QP:

- Michel Mailloux, P.Eng. (ex-Golder) for the hydrogeological modelling;
- Cindy Cormier (Golder) for all the groundwater quality data.

The following individuals provided specialist input to Isabelle Larouche, QP:

- Marilène Renaud, P.Eng. (WSP), Sylvain Tousignant, P.Eng. (WSP), Luc Boutin, P.Eng. (WSP) and Martin Bernier, P.Eng. (WSP) provided support for the design of the tailings filtration and paste backfill plant, and estimation of the capital and operational costs, Chapters 13 and 17.

The following individuals provided specialist input to Éric Poirier, QP:

- Jasmine Bibeau (WSP) and Stéphan Dupuis, P. Eng. (WSP) provided support for the design of the earthworks and civil works required for the surface infrastructure and estimated capital costs;
- Martin Bernier, P.Eng. (WSP) provided support for the design of the buildings included in surface infrastructure and estimated capital costs;
- Yves Picard, P.Eng. (WSP) provided support for the design of the mechanical services, pumping and piping included in surface infrastructure and estimated capital costs;
- Luc Boutin, P.Eng. (WSP) provided support for the design of the buildings and infrastructure electrical distribution, services and control included in surface infrastructure and estimated capital costs;
- Annie Plante, P.Eng. (WSP) provided support for the design of the potable and sanitary water treatment systems included in surface infrastructure and estimated capital costs;
- Gino Beauchamp (WSP) provided support for the identification and characterization of the borrow pits.



These specialists are not considered as QPs for the purposes of this NI 43-101 Report.

2.5. Site Visits

2.5.1. Windfall Project Site

The following bulleted list describes which Qualified Persons visited the Windfall site, the date of the visit, and the general objective of the visit:

- Patrick Andrieux (A2GC) visited the Windfall Project on September 28 and 29, 2022. He had discussions with the Osisko engineering personnel and did an underground visit during which the rock mass conditions in proximity to the Lynx 600 Level bulk sample were observed.
- Colin Hardie (BBA) visited the Windfall Project on January 28 and 29, 2021. The purpose of the visit was to review the Windfall Project with the Osisko team. The site visit included visual inspections of cores, a tour of the core storage facility, an underground visit, a review of planned site infrastructure and a survey of numerous drill hole casings in the field of the Project and discussions with geologists from Osisko.
- Patrick Langlais (Entech) visited the site on February 17 to 25 and April 25 to 29, 2022. He worked with the engineering and geology team as well as visited the camp site, existing infrastructure and the underground ramp.
- Mélissa Tremblay (GCM) visited the Windfall Project on September 23, 2021, accompanied by Djecika Mensah (Osisko Mining). They visited the existing surface infrastructure and part of the future site location.
- Pierre-Luc Richard (PLR Resources Inc.) visited the Windfall Project on January 22 and 23, 2022, and on July 22 and 23, 2022 as part of the current mandate. The purpose of the visits was to review the Windfall Project with the Osisko team. The site visits included visual inspections of cores, a tour of the core storage facility, underground visits, and a survey of numerous drill hole casings in the field. A review of assaying, QA/QC and drill hole procedures, downhole survey methodologies, and descriptions of lithologies, alterations and structures were also completed during the site visits.
- Yves Boulianne (Golder) visited the site on June 28, 2022. He was accompanied by Yan Théberge (Osisko Mining), Nicolas Pépin (Golder) and Aytaç Goksu (Golder). They visited the existing surface infrastructure and the potential TMF locations.
- Frédéric Choquet (WSP) visited the site on September 28, 2022. He was accompanied by Martin Fillion (Osisko Mining). They visited the existing surface infrastructure, more specifically the waste rock stockpile, the overburden stockpile and their afferent collection ditches and basins. Frédéric Choquet also visited the future TMF and surface water management infrastructure locations.



- Ken De Vos (Golder) visited the site on September 28, 2022. He was accompanied by Martin Fillion (Osisko Mining). They visited the existing surface infrastructure and the future TMF and surface water management infrastructure locations. Ken De Vos also inspected select waste rock sample intervals in the waste rock core storage facility.
- Aytaç Göksu (Golder) visited the site on June 28, 2022. He was accompanied by Yan Théberge (Osisko Mining), Yves Boulianne (Golder) and Nicolas Pépin (Golder). They visited the existing surface infrastructure and the future TMF and surface water management infrastructure location.
- Andréanne Hamel (WSP) visited the site on September 28, 2022. She was accompanied by Martin Fillion (Osisko Mining). They visited the existing surface infrastructure and the future TMF and surface water management infrastructure locations. Andréanne Hamel also did an underground visit during which she could observe the water management infrastructures (pumping system and treatment), the groundwater infiltration and the rock mass quality.
- Eric Poirier (WSP) visited the property on October 6, 2020. The purpose of the visit was to assess the existing site infrastructure and collect information required for design.

As of the effective date of this report, the following Qualified Persons have not visited the Windfall Project site:

- Mathieu Bélisle (BBA);
- Isabelle Larouche (WSP).

2.5.2. SGS Laboratory (Québec City)

Mathieu Bélisle (BBA) visited the SGS Metallurgical laboratory in Québec City on June 29, 2022. The visit validated and confirmed that the SGS Québec City laboratory follows the standard sample preparation, metallurgical testwork, assaying and analytical procedures in respect to Industry Standards and in accordance with the NI 43-101.

2.6. Currency, Units of Measurement, and Calculations

Unless otherwise specified or noted, the units used in this report are metric. Every effort has been made to clearly display the appropriate units being used throughout this report.

- Currency is in Canadian dollars ("CAD" or "\$");
- All ounce units are reported in troy ounces, unless otherwise stated; 1 oz (troy) = 31.1 g = 1.1 oz (Imperial);
- All metal prices are expressed in US dollars ("USD");



- A Canadian dollar (CAD) to United States dollar (USD) exchange rate of 0.77 USD for 1.00 CAD was used;
- Cost estimates, unless otherwise stated, have a base date of the fourth quarter (Q4) of 2022.

This report includes technical information that required subsequent calculations to derive subtotals, totals and weighted averages. Such calculations inherently involve a degree of rounding and consequently introduce a margin of error. Where these occur, the QPs consider them immaterial.

2.7. Definitions

The Mineral Resources and Mineral Reserves definitions used for this report follow the May 19, 2014 “CIM Definition Standards – for Mineral Resources and Mineral Reserves” and the November 29, 2019 “CIM Estimation of Mineral resources and Mineral Reserves Best Practice Guidelines”. The QPs believe that these definitions are important with respect to understanding Resources and Reserves and how they are applied within the context of an FS.

2.8. Acknowledgement

BBA and the other study contributors would like to acknowledge the general support provided by numerous personnel during this assignment.

The Project benefitted from the specific input of: Kim-Quyên Nguyễn, Yan Théberge, Louis Grenier, Isabelle Roy, Judith St-Laurent, Antoine Fecteau, Louis-Mathieu Tremblay, Julien Avard, Don Njegovan, Mathieu Savard, Frédéric Côté, Eric Meilleur, Charles Blais, Salvatore Spataro, Eric Gilbert, Éric Gagnon, Piero Hardy, Andréanne Boisvert, Vanessa Millette, Martin Fillion, Jean-Filippe Rochette, Catherine Ménard, David Poirier, Ronald Bougie, Ricardo Esteban, Manon Dussault and Mary Norman. Their contributions are gratefully acknowledged.



3. Reliance on Other Experts

The Qualified Persons ("QPs") have relied on reports, information sources and opinions provided by Osisko and outside experts related to the Project's mineral rights, surface rights, property agreements, royalties, third party agreements and fiscal situation.

As of the date of this report, Osisko indicates that there are no known litigations potentially affecting the Windfall Project.

A draft copy of the report has been reviewed for factual errors by Osisko. Any changes made as a result of these reviews did not involve any alteration to the conclusions made. Hence, the statements and opinions expressed in this document are given in good faith and in the belief that such statements and opinions are neither false nor misleading at the date of this report.

3.1. Mineral Tenure and Surface Rights

Osisko supplied information about mining titles, option agreements, royalty agreements, environmental liabilities and permits. Colin Hardie, QP, consulted the Québec Government's (*Ministère des Ressources naturelles et des Forêts*) online claim management system (GESTIM) via: <https://gestim.mines.gouv.qc.ca/> for the latest status regarding ownership and mining titles.

The QPs are not qualified to express any legal opinion with respect to the property titles or current ownership and possible litigation. A description of such agreements, the property, and ownership thereof, is provided for general information purposes only. In this regard, the QPs have relied on information supplied by Osisko and the work of experts they understand to be appropriately qualified.

This information is used in Chapter 4 (Property Description and Location) of the report. The information is also used in support of the Mineral Resource Estimate in Chapter 14, Mineral Reserves in Chapter 15, and the financial analysis in Chapter 22 (Economic Analysis).

3.2. Taxation and Royalties

Colin Hardie, QP, has fully relied upon, and disclaims responsibility for, information supplied by Osisko staff and experts retained by Osisko related to taxation and royalties as applied to the financial model in Chapter 22 (Economic Analysis).



4. Property Description and Location

4.1 Introduction

The Windfall Project consists of the following three properties:

- Windfall
- Urban-Barry
- Urban Duke

The mineral resource estimate presented in this report is located on the Windfall property. Table 4-1 provides a summary of the three properties.

Table 4-1: Property summary

Property	Claims	Area (ha)
Windfall	286	12,523
Urban-Barry	1,372	74,135
Urban Duke	81	3,590
Total	1,739	90,248

4.2 Location

The Windfall, Urban-Barry and Urban Duke properties are in the province of Québec, Canada. The land package is located east of the town of Lebel-sur-Quévillon, approximately 620 km north-northwest of Montréal and 155 km northeast of Val-d'Or. The Urban-Barry property lies approximately 115 km east of the town of Lebel-sur-Quévillon and surrounds the Windfall property (Figure 4-1). The centre of the Windfall Project is located at approximately 75.66° west longitude and 49.05° north latitude.

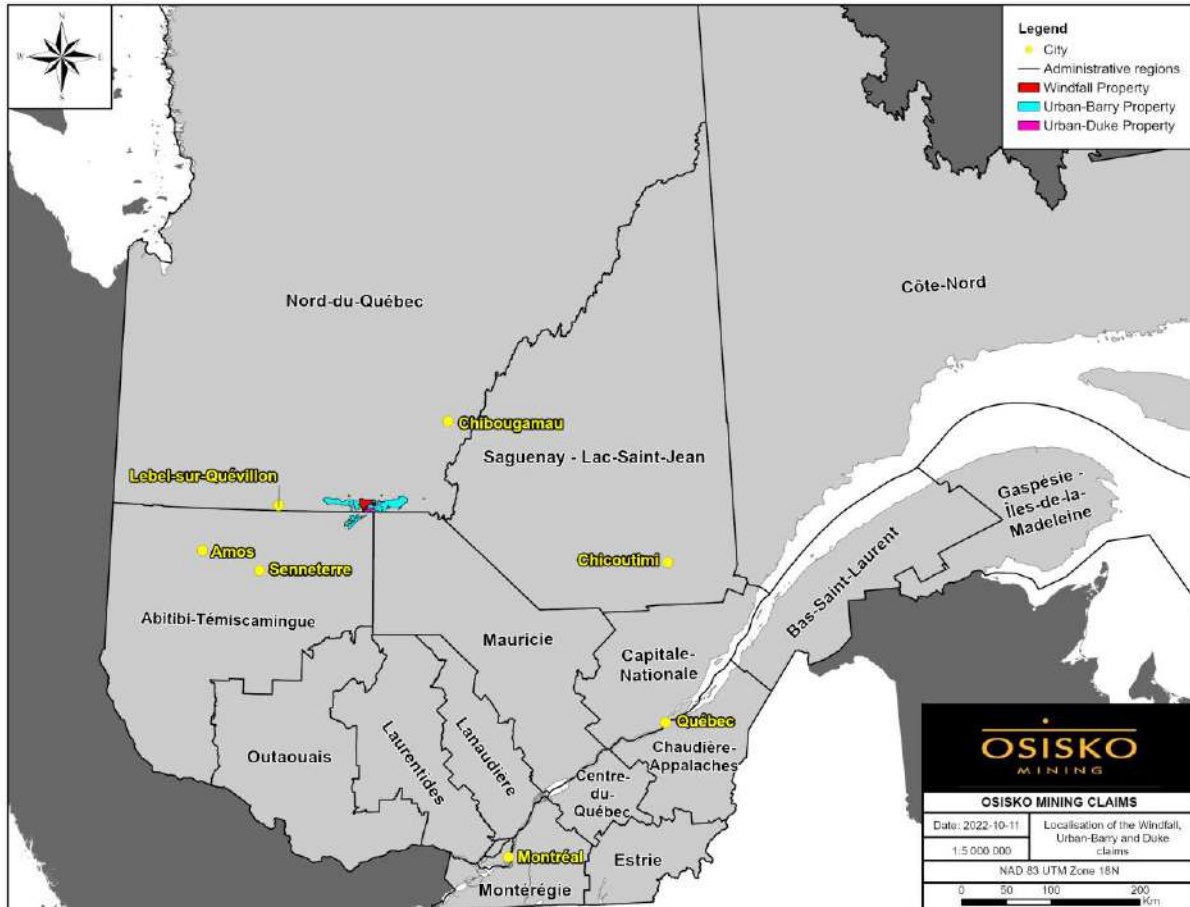

Figure 4-1: Location of the Windfall Project and the Osisko claims in the Province of Québec, Canada, with Provincial Administrative Divisions



4.3 Mining Rights in Québec

The following discussion on the mining rights in the province of Québec was mostly summarized from Guzun (2012), Gagné and Masson (2013), and from the Act to amend the *Mining Act* (Bill 70; the “Amending Act”) assented on December 10, 2013 by the Québec Government.

In the province of Québec, mining is principally regulated by the provincial government. The Ministry of Natural Resources and Forests (“MRNF”: *Ministère des Ressources naturelles et des Forêts du Québec*) is the provincial agency entrusted with the management of minerals in Québec. The *Mining Act* and related regulations primarily govern the ownership and granting of mining titles for minerals. In Québec, land surface rights are distinct property from mining rights. Rights in or over minerals in Québec form part of the domain of the State (the public domain), subject to limited exceptions for privately owned minerals. Mining titles for minerals within the public domain are granted and managed by the MRNF. The granting of mining rights for privately owned minerals is a matter of private negotiations, although the *Mining Act* governs certain aspects of the exploration and mining of such minerals.

4.3.1 The Claim

A claim is the only exploration title for minerals (other than surface minerals, petroleum, natural gas and brine) currently issued in Québec. A claim gives its holder the exclusive right to explore for such minerals on the land subject to the claim. Still, it does not entitle its holder to extract minerals, except for sampling, and only in limited quantities. To mine minerals, the holder of a claim must obtain a mining lease. The electronic map designation is the most common method of acquiring new claims from the MRNF whereby an applicant makes an online selection of available pre-mapped claims. In rare territories, claims can be obtained by staking.

In March 2013, the Québec government converted all remaining staked claims of the Windfall property into one or more map-designated claims. Unlike the perimeter of a staked claim defined by posts staked in the ground, the map-designated claims perimeter is defined by the geographic coordinates as determined by the Québec government. The basic unit is 30 seconds of latitude in a north-south direction, and 30 seconds of longitude in an east-west direction. Depending on the latitude, the designated claim cells vary from 40 ha to 60 ha in area.



4.3.2 The Mining Lease

Mining leases are extraction (production) mining titles that give their holder the exclusive right to mine minerals (other than surface minerals, petroleum, natural gas, and brine). A mining lease is granted to the holder of one or several claims upon proof of the existence of indicators of the presence of a workable deposit on the area covered by such claims and compliance with other requirements prescribed by the *Mining Act*. A mining lease has an initial term of 20 years but may be renewed for three additional periods of 10 years each. Under certain conditions, a mining lease may be renewed beyond the three statutory renewal periods.

4.4 Mining Title Status and Royalties

The status of the claims was supplied by Osisko Mining Inc. ("Osisko"). Colin Hardie, QP has not verified the legal titles to the property or any underlying agreement(s) that may exist concerning the licenses or other agreement(s) between third parties.

4.4.1 Windfall Property

The Windfall property is 100% owned by Osisko. The property is located in the National Topographic System ("NTS") map sheet 32G04 and in the Urban Township. As of October 11, 2022, the property consisted of 286 individual claims covering an aggregate area of 12,523 ha. The actual property was consolidated from several agreements concluded with previous owners and presented in Figure 4-2.

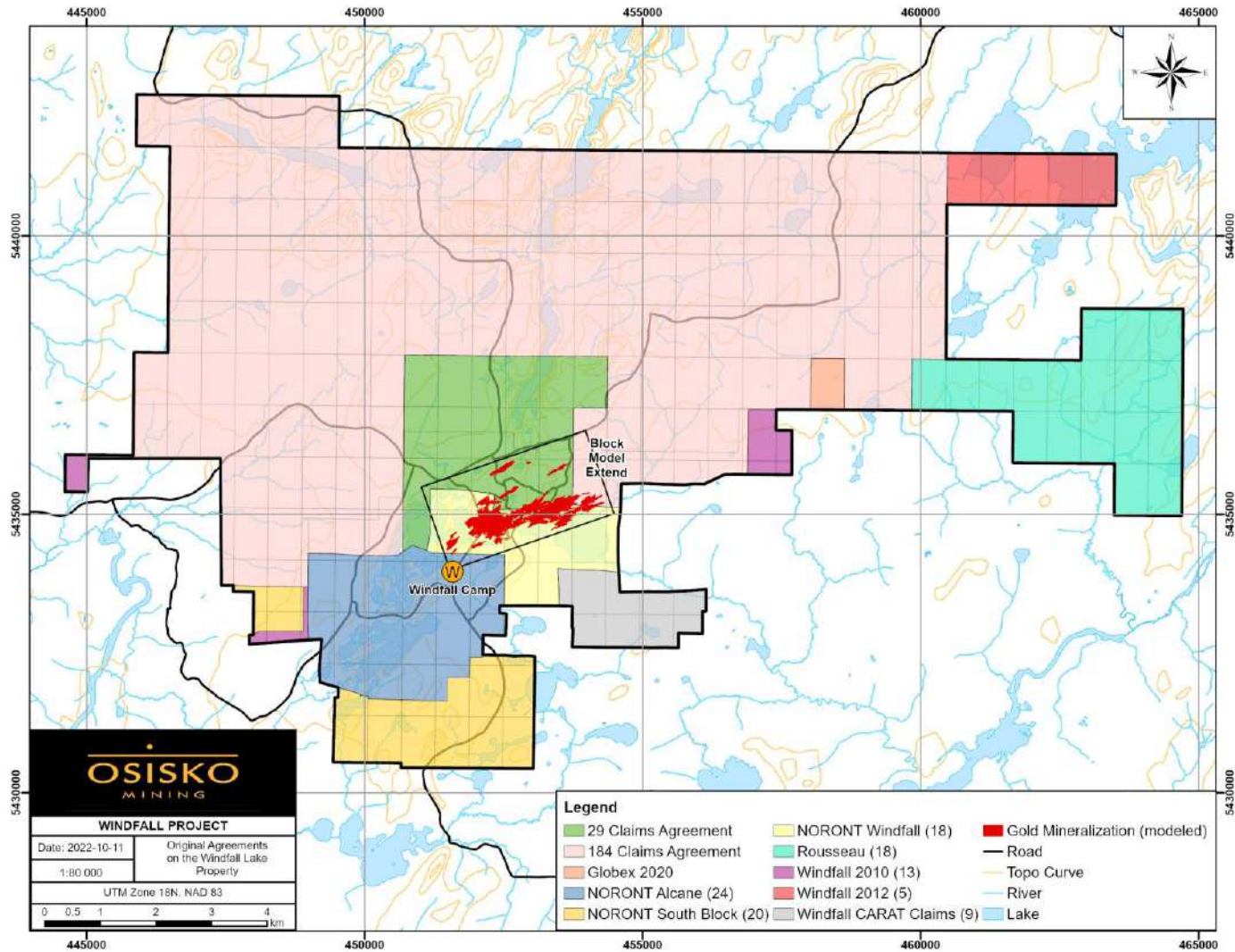

Figure 4-2: Land tenure plan showing the various original agreements on the Windfall property (October 11, 2022)



A summary of the tenure information as extracted from the Québec government GESTIM (*Gestion des Titres Miniers*) website (as of October 11, 2022) is presented in Table 4-2. A detailed listing of the mineral titles for the Windfall property is presented in Appendix A at the end of this report. All claims are in good standing, with expiry dates varying between January 22, 2023 and August 10, 2024. Osisko has sufficient work credit to renew all the claims and maintain them in good standing. The active underlying royalties affecting the different portions of the property are presented in Figure 4-3.

**Table 4-2: Mineral tenure summary of the Windfall property
 (October 11, 2022)**

Option / Joint Venture	Registered Owner	No. of Claims	Area (ha)	Expiry Date (yyyy-mm-dd)	Mineral Resource	Percentage held by Osisko Mining Inc.
Windfall-Noront Option	Osisko Mining Inc.	6	76.48	2023-01-22	Yes	100%
		50	1,794.54	2023-09-25		
The 29 Claims Expansion	Osisko Mining Inc.	9	349.13	2024-03-05	Yes	100%
		13	429.64	2024-03-10		
184 Claims Expansion Includes the Carat Claims	Osisko Mining Inc.	29	1,634.03	2024-06-10	Yes	100%
		13	732.76	2024-09-24		
		15	578.85	2023-12-04		
		6	338.13	2023-12-05		
		40	2,253.41	2023-12-10		
		43	2,222.26	2024-03-05		
		16	282.82	2024-03-10		
		9	274.06	2024-03-20		
Rousseau	Osisko Mining Inc.	11	620.11	2023-05-02	-	100%
		7	394.61	2023-05-03		
Windfall 2010	Osisko Mining Inc.	13	148.15	2023-08-02	-	100%
Windfall 2012	Osisko Mining Inc.	5	281.65	2023-08-14	-	100%
Globex Mining Enterprises Inc.	Osisko Mining Inc.	1	56.37	2024-08-10	-	100%
Total		286	12,523			

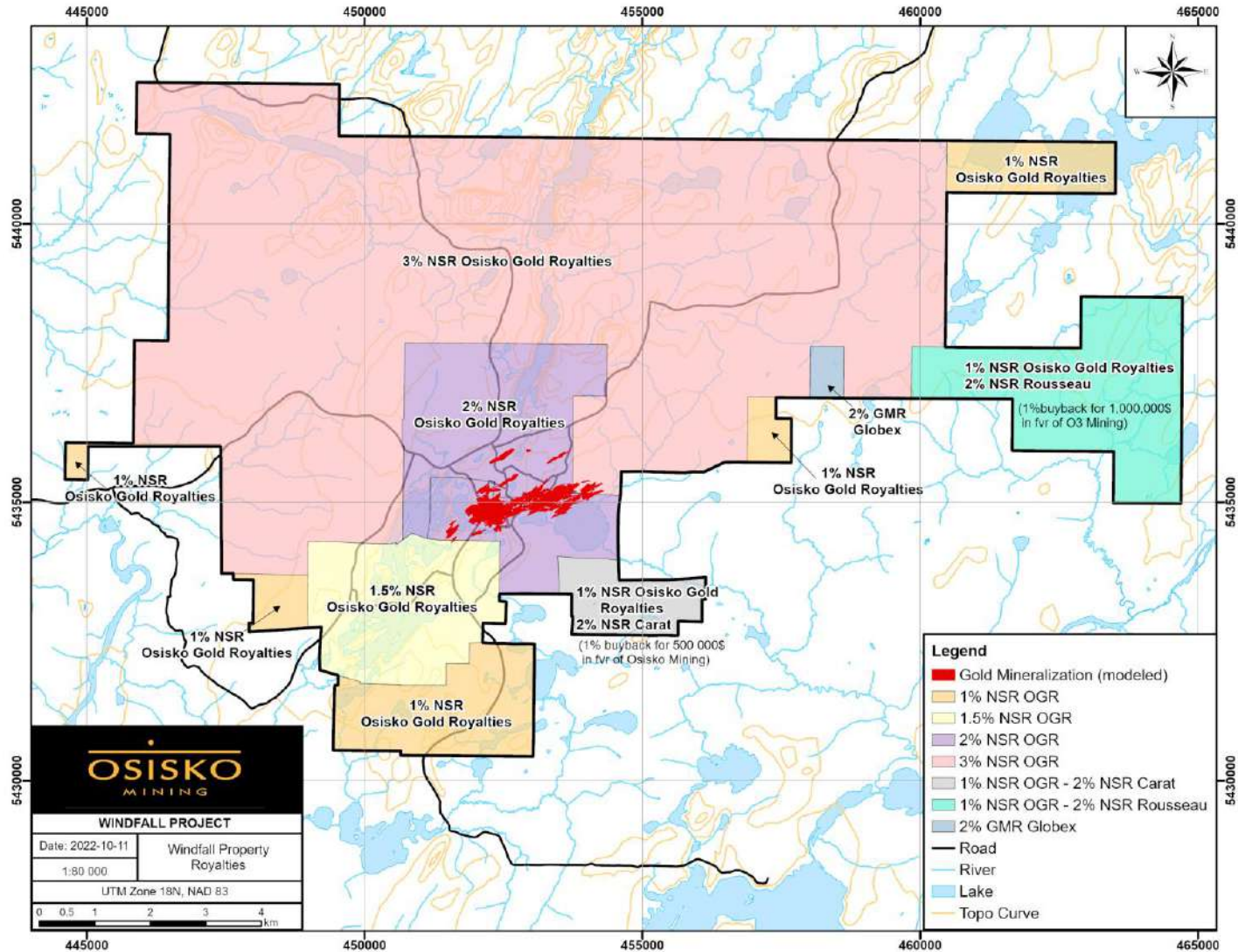

Figure 4-3: Net smelter return royalty agreements for the Windfall property



Osisko's rights to the property arose from several distinct agreements that are discussed in Section 4.4.1.1. The main claim blocks inherited from the original agreement are: The Windfall-Noront Option (including the Windfall, Alcane, and South blocks), 29 Claims Expansion, 184 Claims Expansion, Rousseau property, Windfall 2010, Windfall 2012, and the Carat Claim. Following a series of transactions during the first half of 2014, Eagle Hill Exploration Corp. (now Osisko Mining Inc.) acquired a 100% interest in all the claim blocks of the property, barring various net smelter return ("NSR") royalties discussed in the following sections.

The mineral resources discussed herein are, in the vast majority, located within the Noront-Windfall block of the Windfall option and the 29 Claims Expansion claim blocks. Very limited mineral resources are located on the 184 claims block as shown in Figure 4-2. The vast majority of the claims located within the Windfall mineral resource estimate are subject to a 1% to 2% NSR to Osisko Gold Royalties, except for the Alcane Block (1.5% NSR) and the 184 Block (3% NSR) (Figure 4-2 and Figure 4-3).

4.4.1.1 Windfall Property Surface Rights Option Agreement

On August 25, 2015, Osisko acquired the company Eagle Hill, which held the Windfall property, resulting in Eagle Hill becoming a wholly owned subsidiary of Osisko. On January 1, 2019, Eagle Hill was amalgamated into Osisko, resulting in it becoming the successor to Eagle Hill's interest in the Windfall property.

The rights to the Windfall property held by Osisko (then Eagle Hill) arise from a series of option agreements executed by Eagle Hill with various third parties during 2009, 2010, 2013, and 2014:

- The original property option agreement with Noront Resources Ltd. ("Noront") in July 2009;
- The 29 Claims Expansion with Noront, Murgor, and Freewest Resources Canada Ltd. ("Freewest") (since acquired by Cliffs) in October 2009;
- The 184 Claims Expansion with Murgor and Cliffs in October 2009;
- The Rousseau joint venture with Murgor on the Rousseau property in March 2010;
- The purchase of Noront's remaining 25% interest in August 2013;
- The purchase of Murgor's and Cliffs' remaining interests in April 2014;
- The purchase of the Duval and the Boudreault royalties in May 2014.



4.4.1.2 Original Windfall Property Option Agreement with Noront

On July 20, 2009, Eagle Hill entered into an option agreement with Noront, pursuant to which Eagle Hill earned a 75% interest in Noront's interests in 80 claims (156 claims prior to the Québec government conversion) in the property area. Eagle Hill could earn, at Noront's option, a 100% interest subject to a 1% NSR. The property included four contiguous blocks (80 claims) covering a total area of 2,757 ha. Noront had a 50% interest in 24 of the claims post-conversion (the 29 Claims Expansion) and a 100% interest in the remaining 56 claims (127 claims prior to conversion) (the Windfall block of claims). Eagle Hill's primary obligations, as outlined in the option agreement, were as follows:

- Complete an equity financing of at least \$1,500,000 on or before October 15, 2009.
- Make an initial consideration payment of \$400,000 upon completion of the above financing and receipt of regulatory approval;
- Incur exploration expenditures on the claims and option payments to earn an interest in the claims as follows:
 - \$500,000 in exploration expenditures and a cash payment of \$200,000 to Noront on or before December 31, 2010 to earn 10% of Noront's interest in the claims;
 - \$2,000,000 in additional exploration expenditures on or before December 31, 2011 to earn 51% of Noront's interest in the claims;
 - \$2,500,000 in additional exploration expenditures and a cash payment of \$400,000 to Noront on or before December 31, 2012 to earn 75% of Noront's interest in the claims.

Purchase of the 100% Interest from Noront

On April 20, 2012, Eagle Hill earned the initial 75% interest in Noront's interest in the property, after completing the required expenditures and payments. On June 28, 2013, Eagle Hill entered into a binding letter agreement to acquire the remaining 25% ownership, all royalties, and all other interests in the mineral claims of the property from Noront, by making aggregate cash payments of \$5,000,000 and issuing 25,000,000 freely tradable common shares of Eagle Hill to Noront. The transaction was completed on August 14, 2013, and as a result, Eagle Hill now held 100% of the Windfall block. A further result was that Eagle Hill held a 75% interest in the 29 Claims Expansion.

The property, originally owned by Noront, is further divided into three blocks, characterized by different NSR agreements with third parties (Figure 4-3).



The Noront-Windfall block, which contains most of the mineral resource, is subject to a 2% NSR as follows:

- 0.5% NSR: On July 26, 2004, Noront and Alto Ventures Ltd. ("Alto") entered into an agreement under which Noront acquired Alto's interest in the Noront-Windfall block (50%) and the Alcane Block (100%) in exchange for Alto retaining a 0.5% NSR royalty over the Noront-Windfall block and the Alcane Block. On April 7, 2014, Virginia Mines Inc. ("Virginia") and Alto entered into a royalty acquisition agreement under which Virginia acquired the 0.5% NSR royalty. On February 17, 2015, Osisko Gold Royalties Ltd. acquired Virginia, resulting in Virginia becoming a wholly owned subsidiary of Osisko Gold Royalties Ltd. Then, on December 31, 2015, Osisko Gold Royalties entered into an assignment agreement with Osisko Explorations James Bay Inc. (formerly named Virginia), its wholly owned subsidiary, such that Osisko Gold Royalties Ltd. now holds this 0.5% NSR royalty directly.
- 0.5% NSR: On January 16, 2020, Osisko and Osisko Gold Royalties Ltd. entered into a royalty agreement pursuant to which a 0.5% NSR royalty was re-granted to Osisko Gold Royalties Ltd. This royalty was repurchased by Osisko from Scandium International Mining Corp., as successor to EMC Metals, Golden Predator Mines, and the successor in interest to Fury Explorations ("Scandium"), and re-granted to Osisko Gold Royalties Ltd. on account of buy-back rights being exercised by Osisko Gold Royalties Ltd. under the investment agreement dated August 25, 2015 between Osisko and Osisko Gold Royalties Ltd. This royalty was originally granted on June 9, 2004 under a letter agreement between Noront and Scandium (then named Fury Explorations) pursuant to which Noront agreed to purchase an assignment of an option agreement dated September 4, 2002 between Scandium (then named Fury Explorations) and Alto. As part of the consideration for the option assignment, Scandium retained a 1% NSR over the interests held by Noront only (i.e., a 50% interest in the Noront-Windfall block). Noront was granted the right to repurchase the 1% NSR for \$1 million (or \$500,000 for each 0.5% NSR), and prior to being exercised, such repurchase rights were held by Osisko.
- 1% NSR: On October 4, 2016, Osisko and Osisko Gold Royalties Ltd. entered into a royalty agreement pursuant to which a 1% NSR royalty was granted to Osisko Gold Royalties Ltd. over all of the properties held by Osisko as of August 25, 2015 (including the Noront-Windfall block). Osisko Gold Royalties was granted the right to receive a 1% royalty over all such properties in exchange for a \$5 million cash payment under the investment agreement dated August 25, 2015 between Osisko and Osisko Gold Royalties Ltd.



The Noront-Alcane block, which contains some of the mineral resource along its northern boundary, is subject to a 1.5% NSR as follows:

- 0.5% NSR: On July 26, 2004, Noront and Alto entered into an agreement under which Noront acquired Alto's interest in the Noront-Windfall block (50%) and the Alcane Block (100%) in exchange for Alto retaining a 0.5% NSR royalty over the Noront-Windfall block and the Alcane Block. On April 7, 2014, Virginia and Alto entered into a royalty acquisition agreement under which Virginia acquired this 0.5% NSR royalty. On February 17, 2015, Osisko Gold Royalties Ltd. acquired Virginia, resulting in Virginia becoming a wholly owned subsidiary of Osisko Gold Royalties Ltd. Then, on December 31, 2015, Osisko Gold Royalties entered into an assignment agreement with Osisko Explorations James Bay Inc. (formerly named Virginia), its wholly owned subsidiary, such that Osisko Gold Royalties Ltd. now holds this 0.5% NSR royalty directly.
- 1% NSR: On October 4, 2016, Osisko and Osisko Gold Royalties Ltd. entered into a royalty agreement pursuant to which a 1% NSR royalty was granted to Osisko Gold Royalties Ltd. over all of the properties held by Osisko as of August 25, 2015 (including the Noront-Alcane block). Osisko Gold Royalties was granted the right to receive a 1% royalty over all such properties in exchange for a \$5 million cash payment under the investment agreement dated August 25, 2015 between Osisko and Osisko Gold Royalties Ltd.
- Other Royalty Buy-Back: On May 6, 2014, Eagle Hill bought back and cancelled the 2% NSR royalty then held by Boudreault on the Noront-Alcane block.

The Noront South block was not subject to any NSR royalty inherited from the Noront. However, as described above, the Noront South block is subject to a 1% NSR royalty in favour of Osisko Gold Royalties as follows:

- 1% NSR: On October 4, 2016, Osisko and Osisko Gold Royalties Ltd. entered into a royalty agreement pursuant to which a 1% NSR royalty was granted to Osisko Gold Royalties Ltd. over all of the properties held by Osisko as of August 25, 2015 (including the Noront South block). Osisko Gold Royalties was granted the right to receive a 1% royalty over all such properties in exchange for a \$5 million cash payment under the investment agreement dated August 25, 2015 between Osisko and Osisko Gold Royalties Ltd.

As noted above, these three blocks are subject to the following NSR royalties: (i) the Noront Windfall block is subject to a 2% NSR royalty in favour of Osisko Gold Royalties Ltd.; (ii) the Noront-Alcane block is subject to a 1.5% NSR royalty in favour of Osisko Gold Royalties Ltd.; and (iii) the Noront South block is subject to a 1% NSR royalty in favour of Osisko Gold Royalties Ltd.



4.4.1.3 Original Windfall Property Expansion with Murgor and Cliffs

On October 8, 2009, Eagle Hill entered into two separate agreements with Murgor and Cliffs to increase its holdings at the property. Eagle Hill, Murgor, and Cliffs agreed to an amendment to the option agreements on November 23, 2011. The following section describes the details of the option agreements with Murgor and Cliffs.

The 29 Claims Expansion and the 184 Claims Expansion - Murgor and Cliffs

The first of these agreements was an option to acquire the remaining 50% interest in the 29 Claims Expansion block from Murgor and Cliffs. Eagle Hill had acquired the other 50% of these claims through completion of its agreements with Noront. The number of claims was established at 24 claims (for a total of 891 ha), following the consolidation of staked claims into map-designated claims. The terms of the option agreement with Murgor and Cliffs on the 29 Claims Expansion were as follows:

- During the year ended October 31, 2010, Eagle Hill earned an additional 10% interest in the 29 Claims Expansion by issuing 2,500,000 common shares, making a cash payment of \$300,000, incurring \$400,000 in exploration expenditures, and issuing to Murgor and Cliffs a 2% NSR.
- For an additional 15% interest in the 29 Claims Expansion, Eagle Hill had to incur an additional \$1,600,000 in exploration expenditures on or before April 30, 2012.
- For the remaining 25% interest in the 29 Claims Expansion, Eagle Hill had to incur an additional \$2,000,000 of exploration expenditures on or before December 31, 2012.

The second agreement was an option to earn up to 100% interest in an additional 172 claims (184 claims prior to conversion) contiguous to the property from Murgor and Cliffs ("the Optionors"). In the event that Eagle Hill did not earn more than a 50% interest in these claims, Murgor and Cliffs had the right to re-purchase such interest for \$255,000. In the event that Eagle Hill ultimately earned 100% interest in these claims but did not complete a bankable feasibility study within three years from the date the 100% interest was earned, Murgor and Cliffs had the right to re-purchase the 100% interest in these claims from Eagle Hill for \$1,755,000. The terms of this option agreement were as follows:

- For an initial 20% interest in the claims, Eagle Hill had to:
 - Issue 1,000,000 common shares to the Optionors on or before October 31, 2009;
 - Pay \$100,000 to the Optionors on or before December 31, 2010; and
 - Incur \$350,000 of exploration expenditures on or before December 31, 2010.
- For an additional 30% interest in the claims, Eagle Hill had to incur an additional \$500,000 of exploration expenditures on or before April 30, 2012.
- For the remaining 50% interest in the claims, Eagle Hill had to incur an additional \$650,000 of exploration expenditures on or before December 31, 2012.



Consolidation of the Windfall Property Extension

On March 13, 2014, Eagle Hill entered into an agreement with Murgor and Cliffs to purchase the remaining interests in the 29 Claims Expansion and the 184 Claims Expansion. In consideration for the remaining interest in the claims, Eagle Hill paid \$250,000 and issued 9,500,000 common shares to each of Murgor and Cliffs.

In addition, Eagle Hill granted a 0.5% NSR for the 29 Claims and a 1% NSR for the 184 Claims to each of Murgor and Cliffs. Eagle Hill retained the right to buy back any of the NSRs at any time prior to first commercial production, by paying \$500,000 to each holder of the NSR.

On April 7, 2014, Murgor sold all its interests in the property to Gold Royalties Corporation ("Gold Royalties"). The 29 Claims Expansion is subject to a 0.5% NSR to each of Gold Royalties and Cliffs, and the 184 Claims Expansion is subject to a 1% NSR to each of Gold Royalties and Cliffs.

Following the acquisition of Gold Royalties by Sandstorm Gold Ltd. On April 24, 2015, the 29 Claims Expansion subject to a 0.5% NSR and the 184 Claims Expansion subject to a 1% NSR are therefore owned by Sandstorm Gold Ltd.

In addition, one portion of the 29 Claims Expansion was subject to a 2% NSR to Duval, and another distinct portion of the 29 Claims Expansion was subject to a 2% NSR to Boudreault (Figure 4-3). On May 6, 2014, Eagle Hill acquired the NSRs from Duval and Boudreault by paying \$30,000 and issuing 1,666,667 shares of Eagle Hill to each of the vendors.

In order to finance the acquisition of Cliffs Naturals Resources Inc. subsidiaries ("Cliffs Chromite Ontario Inc.") by Noront concluded on April 28, 2015, Noront entered into an amended and restated US\$25 million loan agreement with Franco-Nevada in exchange for 3% NSR over the Black Thor chromite deposit and a 2% royalty over all of Noront's property excluding Eagle's Nest. In addition, Noront received US\$3.5 million in cash consideration as part of the granting of the royalty over the existing Noront property. Considering that Noront acquired Cliffs Chromite Ontario Inc. on March 22, 2015 (amended on April 17, 2015), which owned a 0.5% NSR royalty over 29 Claims Expansion and a 1% NSR over of the 184 Claims Expansion of the Windfall Project, and following the subsequent transaction between Noront and Franco-Nevada, the latter is considered to hold a 0.5% NSR royalty over 29 Claims Expansion and a 1% NSR over of the 184 Claims Expansion.

Both of the NSR royalties on the 29 Claims Expansion and the 184 Claims Expansion were subject to buyback rights. Such royalties were bought back by Osisko (or Eagle Hill) and re-granted to Osisko Gold Royalties Ltd. as described below.



The 29 Claims Expansion, which contains some of the mineral resource in its southeastern boundary, is subject to a 2% NSR royalty, and the 184 Claims Expansion is subject to a 3% NSR royalty, as follows:

- 0.5% NSR (29 Claims) and 1% (184 Claims): On November 16, 2018, Osisko (then Eagle Hill) and Osisko Gold Royalties Ltd. entered into an amended and restated royalty agreement pursuant to which a 0.5% NSR royalty over the 29 Claims Expansion and a 1% NSR Royalty over the 184 Claims Expansion was repurchased and re-granted to Osisko Gold Royalties Ltd. These royalties were repurchased by Osisko from Franco Nevada (as successor to the interest of Cliffs Chromite Ontario Inc.) under the royalty agreement dated March 28, 2014, and re-granted to Osisko Gold Royalties Ltd. on account of buy-back rights being exercised by Osisko Gold Royalties Ltd. under the investment agreement dated August 25, 2015 between Osisko and Osisko Gold Royalties Ltd.
- 0.5% NSR (29 Claims) and 1% (184 Claims): On November 16, 2018, Osisko (then Eagle Hill) and Osisko Gold Royalties Ltd. entered into an amended and restated royalty agreement pursuant to which a 0.5% NSR royalty over the 29 Claims Expansion and a 1% NSR Royalty over the 184 Claims Expansion was repurchased and re-granted to Osisko Gold Royalties Ltd. These royalties were repurchased by Osisko from Sandstorm Gold Ltd. (as successor in interest to Murgor Resources Inc.) under the royalty agreement dated March 28, 2014, and re-granted to Osisko Gold Royalties Ltd. on account of buy-back rights being exercised by Osisko Gold Royalties Ltd. under the investment agreement dated August 25, 2015 between Osisko and Osisko Gold Royalties Ltd.
- 1% NSR: On October 4, 2016, Osisko and Osisko Gold Royalties Ltd. entered into a royalty agreement pursuant to which a 1% NSR royalty was granted to Osisko Gold Royalties Ltd. over all of the properties held by Osisko as of August 25, 2015 (including the 29 Claims Expansion and the 184 Claims Expansion). Osisko Gold Royalties was granted the right to receive a 1% royalty over all such properties in exchange for a \$5 million cash payment under the investment agreement dated August 25, 2015 between Osisko and Osisko Gold Royalties Ltd.

4.4.1.4 The Rousseau Property Joint Venture

In May 2010, Eagle Hill entered into a joint venture agreement with Murgor (the Rousseau Joint Venture) whereby an equal partnership joint venture was formed.

The Rousseau Joint Venture purchased 100% of a group of 18 mineral claims, contiguous to the property, from another non-related company (9187-1400 Québec Inc.) subject to a 2% NSR. Eagle Hill's share of the cost to acquire these claims was \$5,000 and 100,000 common shares.



On August 2, 2011, Eagle Hill entered into an agreement whereby it acquired the remaining 50% of the Rousseau Joint Venture by paying \$5,000 and issuing 200,000 common shares to Murgor. Eagle Hill now holds a 100% interest in the Rousseau property claims block, subject to the NSR provisions of the original agreement. Eagle Hill has the right to buyback the 1% NSR royalty on the Rousseau Joint Venture claims in exchange for \$1 million. On October 3, 2018, Osisko (then Eagle Hill) provided written notice to 9187-1400 Québec Inc. of its buyback of 1% of the NSR royalty in exchange for \$1 million, in accordance with Section 3.2 of the Option Agreement. Osisko (then Eagle Hill) has not yet received a response from 9187-1400 Québec Inc. in respect of its exercise of such buyback rights.

In addition, the remaining 1% NSR royalty on the Rousseau Joint Venture claims is subject to a right of first refusal in favour of Murgor Resources Inc., an indirect wholly-owned subsidiary of O3 Mining Inc., which it acquired further to its business combination with Alexandria Minerals Corp., which closed on August 1, 2019.

The Rousseau Joint Venture claims are subject to a 1% NSR royalty in favour of Osisko Gold Royalties pursuant to a royalty agreement dated October 4, 2016 between Osisko and Osisko Gold Royalties Ltd. Osisko Gold Royalties was granted the right to receive a 1% royalty over all such properties in exchange for a \$5 million cash payment under the investment agreement dated August 25, 2015 between Osisko and Osisko Gold Royalties Ltd.

4.4.1.5 Windfall 2010

In August 2010, Eagle Hill staked 13 mineral claims (7 claims pre-conversion), covering 102.16 ha, to make the property contiguous. These claims were registered under the name Murgor, as Murgor was operating the exploration activities for Eagle Hill at the time and were subsequently transferred to Eagle Hill. These claims are subject to a 1% NSR royalty that was granted to Osisko Gold Royalties Ltd. over all of the properties held by Osisko as of August 25, 2015.

4.4.1.6 Windfall 2012

In August 2012, Eagle Hill staked five claims (281.65 ha) in the northeast corner of the property to cover the extension of a favourable structure in an underexplored sector. These claims are subject to a 1% NSR royalty that was granted to Osisko Gold Royalties Ltd. over all the properties held by Osisko as of August 25, 2015.



4.4.1.7 Virginia Mines Alto' NSR acquisition in 2014

On July 26, 2004, Noront and Alto entered into an agreement under which Noront acquired Alto's interest in the Noront-Windfall block (50%) and the Alcane Block (100%) in exchange for Alto retaining a 0.5% NSR royalty over the Noront-Windfall block and the Alcane Block. On April 7, 2014, Virginia and Alto entered into a royalty acquisition agreement under which Virginia acquired this 0.5% NSR royalty. On February 17, 2017, Osisko Gold Royalties Ltd. acquired Virginia, resulting in Virginia becoming a wholly owned subsidiary of Osisko Gold Royalties Ltd. Then, on December 31, 2015, Osisko Gold Royalties entered into an assignment agreement with Osisko Explorations James Bay Inc. (formerly named Virginia), its wholly owned subsidiary, such that Osisko Gold Royalties Ltd. now holds this 0.5% NSR royalty directly

4.4.1.8 Investment Agreement and Royalty Agreement

On October 4, 2016, Osisko and Osisko Gold Royalties Ltd. entered into a royalty agreement pursuant to which a 1% NSR royalty was granted to Osisko Gold Royalties Ltd. over all of the properties held by Osisko as of August 25, 2015. Osisko Gold Royalties was granted the right to receive such 1% royalty over all such properties in exchange for a \$5 million cash payment under the investment agreement dated August 25, 2015 between Osisko and Osisko Gold Royalties Ltd.

For additional background, Osisko Gold Royalties Ltd. entered into the investment agreement dated August 25, 2015 in conjunction with the closing of the business combination of Osisko (then Oban Mining Corporation), Eagle Hill, Corona Gold Corporation and Ryan Gold Corp. further to which Osisko Gold Royalties Ltd. invested \$17.8 million in, and became a 19.9% shareholder of, Osisko (then Oban Mining Corporation).

Under the aforementioned investment agreement, Osisko Gold Royalties Ltd. was granted certain rights so long as it holds 10% of the issued and outstanding common shares of Osisko on a non-diluted basis, including: (i) a right of first refusal to participate in royalties and streams created by Osisko; (ii) pro rata financing participation rights; and (iii) a one-time right (which was exercised on October 4, 2016) for a period of five years, should Osisko seek financing in debt or equity markets, to provide financing of \$5 million in exchange for a 1% net smelter return royalty over such properties as are wholly owned by Osisko as of August 25, 2015.



4.4.1.9 Repurchase of Royalty

Osisko Gold Royalties has exercised its rights under the investment agreement dated August 25, 2015 to cause Osisko to buyback and re-grant to it three royalties, as follows:

- 0.5% NSR Noront-Windfall Block: On January 16, 2020, Osisko and Osisko Gold Royalties Ltd. entered into a royalty agreement pursuant to which a 0.5% NSR royalty was re-granted to Osisko Gold Royalties Ltd. This royalty was repurchased by Osisko from Scandium International Mining Corp., as successor to EMC Metals, Golden Predator Mines, and the successor in interest to Fury Explorations (Scandium), and re-granted to Osisko Gold Royalties Ltd. on account of buy-back rights being exercised by Osisko Gold Royalties Ltd. under the investment agreement dated August 25, 2015 between Osisko and Osisko Gold Royalties Ltd. See Section 4.4.1.8.
- 0.5% NSR (29 Claims) and 1% (184 Claims): On November 16, 2018, Osisko (then Eagle Hill) and Osisko Gold Royalties Ltd. entered into an amended and restated royalty agreement pursuant to which a 0.5% NSR royalty over the 29 Claims Expansion and a 1% NSR Royalty over the 184 Claims Expansion was repurchased and re-granted to Osisko Gold Royalties Ltd. These royalties were repurchased by Osisko from Franco Nevada (as successor to the interest of Cliffs Chromite Ontario Inc.) under the royalty agreement dated March 28, 2014.
- 0.5% NSR (29 Claims) and 1% (184 Claims): On November 16, 2018, Osisko (then Eagle Hill) and Osisko Gold Royalties Ltd. entered into an amended and restated royalty agreement pursuant to which a 0.5% NSR royalty over the 29 Claims Expansion and a 1% NSR royalty over the 184 Claims Expansion was repurchased and re-granted to Osisko Gold Royalties Ltd. These royalties were repurchased by Osisko from Sandstorm Gold Ltd. (as successor in interest to Murgor Resources Inc.) under the royalty agreement dated March 28, 2014.



4.4.2 Urban-Barry Property

The Urban-Barry property is 100% owned by Osisko. As of October 11, 2022, the property comprises 1,372 individual claims covering an aggregate area of approximately 74,135 ha (Table 4-3). The actual property is mostly constituted by claims that were acquired through designation from GESTIM at different period from 2015 to 2019. Claims acquired from agreement from Multi-Ressources Boréal, from Terrence Coyle from H el ene Lalibert e, and Jean Fournier and Silverwater Capital Corporation ("Silverwater") were consolidated within the Urban-Barry party as shown in Figure 4-4. Claims that were acquired through the acquisition of Beaufield Consolidated Resources were also merge into the Urban-Barry property as shown on Figure 4-4. The claims are distributed in 17 townships, Barry, Beaucourt, Belmont, Bressani, Buteux, Carpiquet, Effiat, Chambalon, Lacroix, Lespinay, Marceau, Maseres, Picquet, Prevert, Ralleau, Souart, and Urban. The property lies on NTS map sheets 32B13, 32B14, 32F01, 32G02, 32G03, and 32G04.

The following NSRs are applicable for the Urban-Barry property: (i) a 1% NSR royalty in favour of Osisko Gold Royalties; (ii) a 2% NSR royalty to Multi-Ressources Bor al (buyback 2% for \$2 million); (iii) a 1% NSR royalty to Terrence Coyle (buyback 1% for \$1 million); (iv) a 2% NSR royalty to H el ene Lalibert e (buyback 2% for \$0.3 million); (v) a 1% NSR royalty to Silverwater (buyback 1% for \$1 million); and (vi) a 2% GMR royalty to Globex Mining).

Following the acquisition of Beaufield by Osisko on October 15, 2018, and the subsequent amalgamation on January 1, 2019 of Beaufield into Osisko, all of Beaufield's claims and agreements in the Urban-Barry area were inherited by Osisko, including the following royalties: (i) a 3% NSR royalty on Alto claims (2% NSR royalty in favour of Alcudia and 1% NSR royalty in favour of Alto) (buyback 0.5% of Alto's royalty for \$1 million); (ii) a 2% NSR royalty held by Wayne Holmstead (buyback 1% for \$500,000); (iii) a 1.5% NSR royalty held by Garnet Gold Inc. (buyback 0.75% NSR royalty for \$0.5 million); (iv) a 2% NSR royalty held by Hinterland Metals Inc. (buyback 1% for \$1 million); (v) a 2.3% NSR royalty held by the NAM Group (buyback 1% for \$1 million); (vi) a 1.5% Desrosiers Group NSR royalty; (vii) a 10% NPR royalty formerly held Jason Resources Inc., which was dissolved with no known successor; and (viii) a 2% NSR royalty held by Teck (Beaufield has a right of first refusal on the sale or transfer of the NSR royalty) (Figure 4-4).

A summary of the tenure information, as extracted from the Qu ebec government GESTIM on October 11, 2022, is presented in Table 4-3. All claims are in good standing, with expiry dates varying between August 8, 2022 and February 21, 2025. A complete listing of the mineral titles for the Urban-Barry property is presented in Appendix B. Osisko may not, for strategic or prospectivity reason, renew all of the 1,465 claims of the Urban-Barry property but they are currently all in good standing. Given the size and the scale of the Urban-Barry property, Osisko, might, from time to time, abandon or let lapse some claims presenting less potential for mineral exploration. On the other hand, Osisko might also acquire additional claims presenting good potential for mineral exploration.



The active underlying royalties affecting the different portions of the Urban-Barry property are presented in Figure 4-4. The boundaries of the claims have not been surveyed legally.

**Table 4-3: Mineral tenure summary of the Urban-Barry property
 (October 11, 2022)**

Option / Joint Venture	Registered Owner	No. Of Claims	Area (ha)	Expiry Date (AAAA-MM-JJ)	Mineral Resource	Percentage held by Osisko Mining Inc.
Urban-Barry Project Initial Claims Designation	Osisko Mining Inc.	71	4,005.34	2023-11-24	-	100%
		43	2,422.81	2023-11-25		
		202	11,396.69	2023-11-30		
		74	4,171.8	2023-12-01		
		93	5,240.52	2023-12-02		
		218	12,299.95	2023-12-03		
		101	5,699.44	2023-12-04		
		2	112.9	2023-12-07		
		41	2,316.4	2023-12-29		
Terrence Coyle Claim Acquisition	Osisko Mining Inc.	2	112.76	2022-08-20	-	100%
		2	112.72	2024-05-10		
		1	56.35	2024-05-18		
Urban-Barry Project Additional Claims Designation	Osisko Mining Inc.	8	451.21	2024-08-10	-	100%
		3	169.18	2022-11-20		
		1	56.41	2023-03-14		
		1	56.38	2023-04-11		
		46	2,589.88	2023-04-25		
		2	112.62	2023-05-04		
		2	112.71	2023-05-17		
		1	56.42	2023-06-17		
		1	43.81	2023-06-21		
		8	103.1	2023-06-22		
		9	506.98	2023-07-16		
		3	57.12	2023-07-21		
		162	9,129.72	2023-08-30		
		2	112.67	2023-09-22		
		1	56.4	2023-09-23		
		18	1,019.28	2024-01-04		
		2	112.66	2024-01-08		



Option / Joint Venture	Registered Owner	No. Of Claims	Area (ha)	Expiry Date (AAAA-MM-JJ)	Mineral Resource	Percentage held by Osisko Mining Inc.
		4	225.55	2024-01-30		
		4	225.64	2024-02-14		
		1	56.52	2024-02-20		
		2	113.11	2024-05-04		
		1	56.42	2024-05-23		
		6	338.07	2025-02-21		
Multi-Ressources Boréal Claim Acquisition	Osisko Mining Inc.	33	1,286.43	2024-07-30	-	100%
Urban-Barry Project additional claims from Beaufield	Osisko Mining Inc.	16	557.77	2024-08-08	-	100%
		12	588.01	2023-01-13		
		9	507.57	2023-04-22		
		8	18.33	2023-07-12		
		62	2,944.27	2023-11-10		
		8	161.53	2023-11-22		
		5	281.94	2023-12-14		
		21	901.84	2023-12-31		
		14	789.78	2024-03-04		
		4	226.51	2024-03-07		
		9	298.7	2024-03-20		
		5	282.81	2024-04-09		
		7	394.64	2024-05-03		
		4	225.53	2024-06-01		
		3	169.56	2024-07-07		
1	56.36	2024-07-29				
Silverwater Capital Corp.	Osisko Mining Inc.	2	112.78	2023-08-01	-	100%
		2	112.79	2023-08-10		
Globex Mining Enterprises Inc.	Osisko Mining Inc.	3	169.18	2024-08-10	-	100%
		2	113.11	2024-05-04		
Jean Fournier	Osisko Mining Inc.	3	169.23	2023-08-16	-	100%
Jon Deluce	Osisko Mining Inc.	1	56.4	2024-06-16	-	100%
Total		1,372	74,135	-		

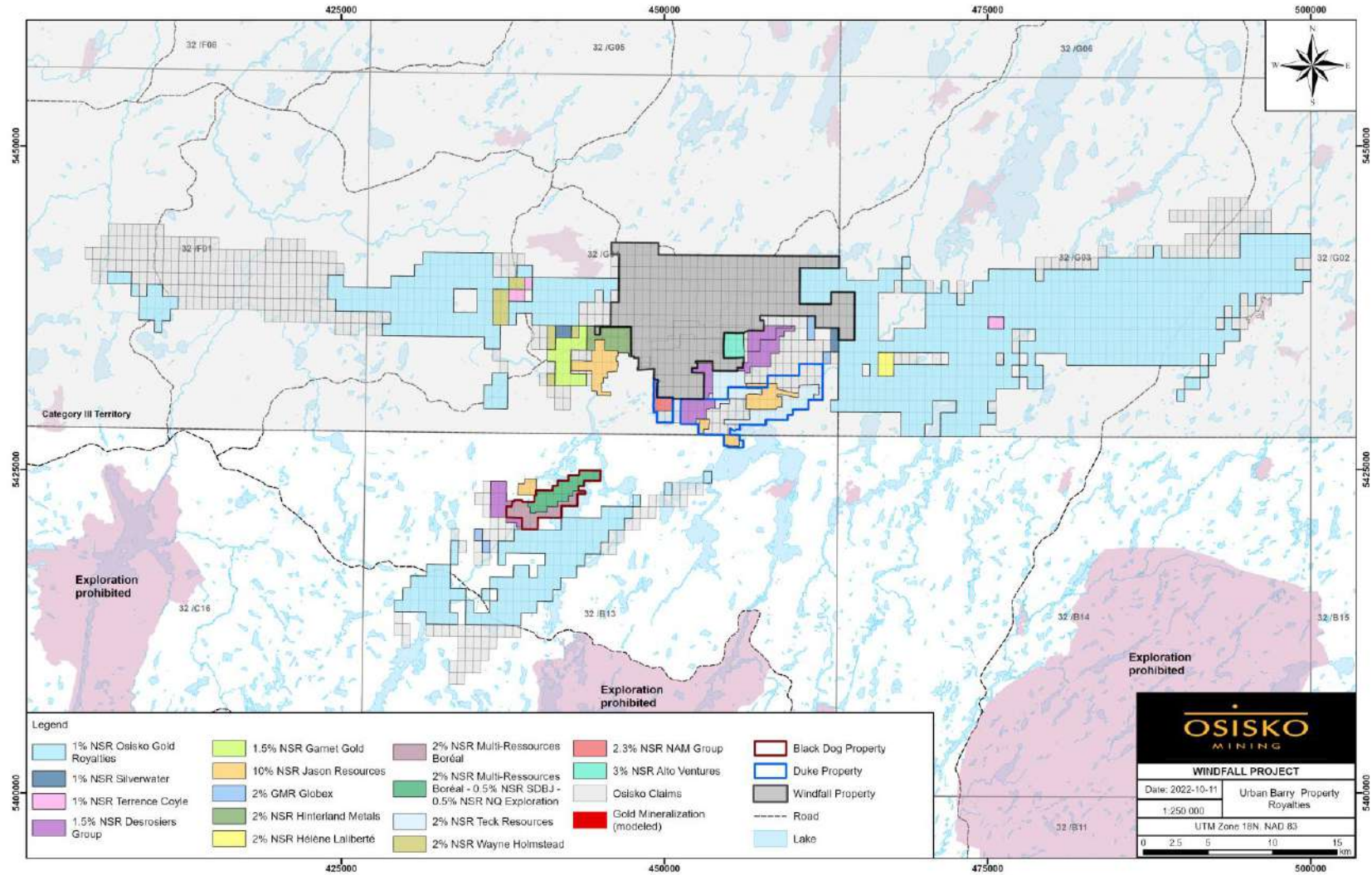

Figure 4-4: Claim map of the Windfall (in gray) and Urban-Barry properties (October 11, 2022) Category III Territory corresponds to Eeyou Istchee land



4.4.2.1 Urban-Barry Surface Rights Agreement Multi Ressources Boréal

On February 2, 2016, Osisko acquired 33 claims from Multi-Ressources Boréal (the Souart property) in exchange for the payment of \$200,000, the issuance of 500,000 shares of Osisko (then Oban Mining Corporation) and a 2% NSR royalty with a buyback of 2% for \$2,000,000. There are two previous historical royalties held by other parties that affect the mineral claims. There is a first 0.5% NSR in favour of "Société de Développement de la Baie James" and a second 0.5% NSR in favour of "NQ Exploration". The Souart property is now a part of the Urban-Barry property.

4.4.2.2 Urban-Barry Surface Rights Agreement from Terrence Coyle

On January 19, 2017, Osisko acquired seven claims from Terrence Coyle in exchange for the payment of \$7,000 and a 1% NSR with a buyback of 1% for \$1,000,000. The claims are now part of the Urban-Barry Project.

4.4.2.3 Urban-Barry Surface Rights Agreement from Hélène Laliberté

On April 10, 2018, Osisko acquired a 100% interest in four claims from Hélène Laliberté. Hélène Laliberté has a 2% NSR royalty right over these claims but Osisko can buy back the 2% (100%) NSR in exchange for the payment of \$300,000. Osisko also kept a right of first refusal on any transaction on these claims.

4.4.2.4 Urban-Barry Surface Rights Agreement from Jean Fournier

On January 8, 2021, Osisko acquired a 100% interest in three claims from Jean Fournier in exchange for the payment of \$400. The claims are now part of the Urban-Barry Project.

4.4.2.5 Urban-Barry Surface Rights Agreement from Beaufield Resources Inc. acquisition

On October 15, 2018, Osisko acquired Beaufield Resources Inc. ("Beaufield") by way of a statutory plan of arrangement under the *Business Corporations Act* (British Columbia). Effective January 1, 2019, Beaufield amalgamated into Osisko, following which Osisko inherited all of Beaufield's claims and agreements in the Urban-Barry area. Several rights affecting the Urban-Barry property have arisen from a series of option agreements executed by Beaufield with third parties during 1986, 2003, 2004, 2014, 2015, 2016, and 2017.



Teck Resources (Formerly Cominco Ltd.) / Agnico Eagle Agreement

Further to an agreement dated on or about May 1993, Teck Resource (formerly Cominco Ltd.) and Agnico Eagle Mines Limited sold their interests in a portion of the Rouleau Block (referred to as the 2% NSR Teck Resources as shown on Figure 4-4) to the joint venture between Falconbridge Limited and Beaufield, further to which a 2% NSR royalty was granted to Teck Resources (51%) and Agnico Eagle Mines Limited (49%) with a first right of refusal in favour of Beaufield (now Osisko). Falconbridge Limited was later acquired by Kinross in 1993. Kinross sold its interest in the claims to Beaufield in 2003, which resulted in Beaufield owning 100% of the claims.

Jason Resources (Dissolved on January 19, 1994)

A portion of the Rouleau Block, Southern part of Macho and a portion of the Kent Block were sold by Jason Resource Inc. to Kidd Creek in 1982. Jason Resource Inc. kept a 10% net profits royalty ("NPR") over these claims. In 1986, Beaufield acquired a 49% interest in these claims from Kidd Creek. Kidd Creek was acquired by Falconbridge Gold in 1986, which was then acquired by Kinross in 1993. Kinross sold the balance of the property to Beaufield in 2003. Jason Resources Inc. was dissolved on January 19, 1994, with no known successor to this 10% NPR royalty. As a result, Osisko does not acknowledge the existence of this 10% NPR royalty (referred to as 10% NPR Jason Resources as shown on Figure 4-4).

Desrosiers Group

Certain claims from the western portion of the Rouleau Block were acquired by Beaufield from François Des Rosiers, MJL Exploration Inc. and Geotest Corp. ("Desrosiers Group") on October 27, 2004. Each of the three members of the Desrosiers Group kept a separate 0.5% NSR royalty each over the claims for a total of a 1.5% NSR affecting these claims (referred to as 1.5% NSR Desrosiers Group as shown on Figure 4-4).

NAM Group

On April 6, 2019, North American Exploration Inc. (50%), Garry Majerle (25%) and Michel Lavoie (25%) (collectively the NAM Group) sold 100% of their interests in a number of contiguous and non-contiguous mineral claims in the Urban-Barry area to Amseco Exploration Inc. The NAM Group kept a 2.3% NSR royalty on the claims and Amseco kept a buy-back right in respect of 1% of the NSR royalty for \$1 million in cash. Amseco Exploration Inc. transferred the claims to Beaufield in April 2014 for \$3,000 (referred to as 2.3% NSR NAM Group as shown on Figure 4-4).



Hinterland Metals

On March 11, 2016, Hinterland Metals sold its 100% interest in claims located on the Eastern part of the Macho block to Beaufield. Hinterland was granted a 2% NSR royalty over these claims, and Beaufield was granted a right to buy-back 50% of the NSR royalty (i.e., 1% of the NSR royalty) for \$1 million in cash (referred to as 2% NSR Hinterland Metals as shown on Figure 4-4).

Garnet Gold

On July 7, 2015, Beaufield acquired a 100% interest in 14 claims from Garnet Gold Inc. in Urban Township. Garnet Gold kept a 1.5% NSR royalty over these claims. Beaufield has the right to buyback 50% of the NSR royalty (i.e. 0.75% of the NSR royalty) for \$500,000 in cash (referred to as the 1.5% NSR Garnet Gold as shown on Figure 4-4).

Wayne Holmstead

On September 12, 2017, Beaufield acquired a 100% interest in 12 claims from Wayne Holmstead in the Urban Township. He was granted a 2% NSR royalty on these claims. Beaufield has the right to buy-back 50% of the NSR royalty (or 1% of the NSR royalty) for \$500,000 (referred to as 2% NSR Wayne Holmstead as shown on Figure 4-4).

Alto Ventures

On February 22, 1996, Alcludia Capital Incorporated ("Alcludia") sold a 100% interest in 20 mineral claims to Alto. Alcludia was granted a 2% NSR royalty (1% NSR royalty in favour of the estate of Bulman and 1% NSR royalty in favour of the estate of Haynes) over these claims. On May 24, 2017, Beaufield acquired a 100% interest in nine of these remaining claims (following claim conversion) from Alto. Alto was granted a 1% NSR royalty on these nine claims, which was in addition to the existing 2% NSR royalty held by Alcludia. Beaufield has the right to buy- back 50% of the NSR royalty (or 0.5% of the NSR royalty) for \$500,000 in cash (referred to as 3% NSR Alto Ventures as shown on Figure 4-4).

4.4.2.6 Urban-Barry Surface Rights Agreement from Globex Mining Enterprises

On August 17, 2020, Osisko acquired a 100% interest in six claims from Globex Mining Enterprises Inc. for a payment amount of \$100,000. Globex has a 2% GMR "Gross Metal" royalty right over these claims. Osisko also kept a right of first refusal on any transaction on these claims.



4.4.2.7 Urban-Barry Surface Rights Agreement from Silverwater Capital Corporation

On August 28, 2020, Osisko acquired a 100% interest in two claims from Silverwater for a payment of \$15,000. Silverwater was granted 1% NSR royalty right over these claims but Osisko can buy back the total of the royalty consisting of 1% NSR in exchange for the payment of \$1,000,000. Osisko also kept a right of first refusal on any transaction on these claims.

On September 27, 2022, Osisko acquired a 100% interest in two claims from Silverwater Capital Corp. for a payment of \$17,000. Silverwater was granted a 1% NSR royalty right over these claims but Osisko can buy back the total of the royalty consisting of 1% NSR in exchange for the payment of \$1,000,000. Osisko also kept a right of first refusal on any transaction on these claims.

4.4.3 Urban Duke Property

The Urban Duke property is a joint venture between Bonterra Resources (70 % interest) and Osisko (30 % interest). The property comprises 81 individual claims covering an aggregate area of approximately 3,590 ha (Table 4-4). Claims were acquired through the acquisition of Beaufield Consolidated Resources resulting in Osisko becoming successor to Beaufield's interest in the Urban Duke property (Figure 4-4). The claims are distributed in 3 townships, Urban, Belmont, and Barry. The property lies on NTS map sheets 32B13 and 32G04.

The following NSRs are applicable for the Urban Duke property: (i) a 2% NSR royalty held by Teck (Beaufield has a right of first refusal on the sale or transfer of the NSR royalty); (ii) a 10% NPR royalty formerly held Jason Resources Inc., which was dissolved with no known successor; (iii) a 1.5% NSR held by the Desrosiers group; and (iv) a 2.3% NSR held by NAM group.

A summary of the tenure information as extracted from the Québec government GESTIM (*Gestion des Titres Miniers*) website (as of October 11, 2022) is presented in Table 4-4. A complete listing of the mineral titles for the Urban Duke property is presented in Appendix C at the end of this report.

**Table 4-4: Mineral tenure summary of the Urban Duke property
(October 11, 2022)**

Option / Joint Venture	Registered Owner	No. Of Claims	Area (ha)	Expiry Date (yyyy-mm-dd)	Mineral Resource	Percentage held by Osisko Mining Inc.
Urban-Barry Duke Option to Bonterra	Osisko Mining Inc.	11	250.15	2023-07-12	-	30%
		69	3,283.22	2023-11-10	-	30%
		1	56.45	2023-07-28	-	30%
Total		81	3,590			



4.4.3.1 Urban-Barry Earn-In Agreement from Beaufield acquisition with Bonterra Resource

On October 19, 2018, Osisko inherited the Urban Duke property by virtue of its acquisition of Beaufield. On January 1, 2019, Beaufield was amalgamated into Osisko, resulting in Osisko becoming the successor to Beaufield's interest in the Urban Duke property. The Urban Duke property is 30% owned by Osisko and is located within the Urban-Barry Greenstone Belt, Québec. On July 6, 2018, Beaufield entered into a binding agreement with Bonterra, which sets forth the terms of an Exploration Earn-In on the property.

In order to earn a 70% interest on the Urban Duke property, Bonterra must commit:

- (i) \$4.5 million in work expenditures over a three-year period, subject to certain annual work expenditure thresholds, including a guaranteed expenditure threshold of \$1.5 million in the first year; and
- (ii) \$750,000 in cash payments over a two-year period, with \$250,000 due upon signing, \$250,000 due in the first year, and the remaining \$250,000 due in the second year. Upon signing on July 6, 2018, and as further consideration for the granting of the exploration earn-in, Bonterra issued 4 million common shares of Bonterra to Beaufield.

The exploration earn-in on the Urban Duke property was completed on July 12, 2021. Osisko and Bonterra will now enter into a joint venture agreement in respect of the property with Bonterra maintaining a 70% interest and Osisko Mining maintaining a 30% interest, (referred to as the Urban Duke JV as shown on Figure 4-4). Bonterra is the operator on the Urban Duke joint venture.

Teck Resources (Formerly Cominco Ltd.) / Agnico Eagle Agreement

Further to an agreement dated on or about May 1993, Teck Resource (formerly Cominco Ltd.) and Agnico Eagle Mines Limited sold their interests in a portion of the Rouleau Block (referred to as the 2% NSR Teck Resources as shown on Figure 4-4) to the joint venture between Falconbridge Limited and Beaufield, further to which a 2% NSR royalty was granted to Teck Resources (51%) and Agnico Eagle Mines Limited (49%) with a first right of refusal in favour of Beaufield (now Osisko). Falconbridge Limited was later acquired by Kinross in 1993. Kinross sold its interest in the claims to Beaufield in 2003, which resulted in Beaufield owning 100% of the claims.



Jason Resources (Dissolved on January 19, 1994)

A portion of the Rouleau Block, Southern part of Macho and a portion of the Kent Block were sold by Jason Resource Inc. to Kidd Creek in 1982. Jason Resource Inc. kept a 10% NPR over these claims. In 1986, Beaufield acquired a 49% interest in these claims from Kidd Creek. Kidd Creek was acquired by Falconbridge Gold in 1986, which was then acquired by Kinross in 1993. Kinross sold the balance of the property to Beaufield in 2003. Jason Resources Inc. was dissolved on January 19, 1994, with no known successor to this 10% NPR royalty. As a result, Osisko does not acknowledge the existence of this 10% NPR royalty (referred to as 10% NPR Jason Resources as shown on Figure 4-4).

4.5 Royalties

4.5.1.1 Windfall Property

The following NSR royalties are applicable for various parts of the Windfall property: (i) 2% Carat (buyback 1% for \$0.5 million); (ii) 2% Rousseau (buyback 1% for \$1 million); (iii) 2% GMR to Globex Mining Enterprises; and (iv) 1.5-3.0% to Osisko Gold Royalties Ltd. (Figure 4-3).

4.5.1.2 Urban-Barry Property

The following NSRs are applicable for the Urban-Barry property: (i) a 1% NSR royalty in favour of Osisko Gold Royalties; (ii) a 2% NSR royalty to Multi-Ressources Boréal (buyback 2% for \$2 million); (iii) a 1% NSR royalty to Terrence Coyle (buyback 1% for \$1 million); (iv) a 2% NSR royalty to Hélène Laliberté (buyback 2% for \$0.3 million); (v) a 1% NSR royalty to Silverwater (buyback 1% for \$1 million); and (vi) a 2% GMR royalty to Globex Mining).

Following the acquisition of Beaufield by Osisko Mining on October 15, 2018, and the subsequent amalgamation on January 1, 2019, of Beaufield into Osisko, all of Beaufield's claims and agreements in the Urban-Barry area were inherited by Osisko, including the following royalties:

- (i) a 3% NSR royalty on Alto claims (2% NSR royalty in favour of Alcudia and 1% NSR royalty in favour of Alto) (buyback 0.5% of Alto's royalty for \$1 million); (ii) a 2% NSR royalty held by Wayne Holmstead (buyback 1% for \$500,000); (iii) a 1.5% NSR royalty held by Garnet Gold Inc. (buyback 0.75% NSR royalty for \$0.5 million); (iv) a 2% NSR royalty held by Hinterland Metals Inc. (buyback 1% for \$1 million); (v) a 2.3% NSR royalty held by the NAM Group (buyback 1% for \$1 million); (vi) a 1.5% Desrosiers Group NSR royalty; (vii) a 10% NPR royalty formerly held Jason Resources Inc., which was dissolved with no known successor; and (viii) a 2% NSR royalty held by Teck (Beaufield has a right of first refusal on the sale or transfer of the NSR royalty) (Figure 4-4).



4.5.2 Urban Duke Property

The following NSRs are applicable for the Urban Duke property: (i) a 2% NSR royalty held by Teck (Beaufield has a right of first refusal on the sale or transfer of the NSR royalty); (ii) a 10% NPR royalty formerly held Jason Resources Inc., which was dissolved with no known successor; (iii) a 1.5% NSR held by the Desrosiers group; and (iv) a 2.3% NSR held by NAM group.

4.6 Constraints and Restrictions

4.6.1 Windfall, Urban-Barry and Urban Duke Properties

The Windfall property and the northern half of the Urban-Barry property are in the Eeyou Istchee James Bay territory (Figure 4-4). Since 2013, this area has been classified as Category III land where exploration is allowed under specific conditions. A claim titleholder is invited to communicate directly with the Cree Nation Government and the Eeyou Istchee James Bay Regional Government.

Five areas where exploration is prohibited under the *Mining Act* are adjacent to the Urban-Barry property (Figure 4-4). They are designated as a “Biological Refuge” and the status triggers a temporary suspension of issuance of mineral titles. One area is an experimental forest where exploration is allowed under specific conditions.

4.7 Permits and Environmental Liabilities

This section provides a summary of current permits, authorizations and environmental liabilities for the Windfall property. Osisko has obtained all necessary permits and authorizations from government agencies to allow for exploration through surface and underground drilling and for bulk sampling.

Permits are required for any exploration program that involves tree cutting to create access for the drill rigs. Osisko has obtained all required permits issued by the *Ministère des Forêts, de la Faune et des Parcs* (“MFFP”) (now the MELCCFP – *Ministère de l'Environnement, de la Lutte contre les changements climatiques, de la Faune et des Parcs*).

The Windfall Project contains three lease agreements, including one industrial lease agreement for the ramp area, another industrial lease agreement for the camp area and a mine waste storage lease.

The camp has a capacity of 300 persons and Osisko has authorizations for three drinking water wells and three septic systems.



At the end of 2018 and the beginning of 2019, Osisko extracted a bulk sample in Zone 27. Prior to proceeding with this work, Osisko obtained an exemption from the environmental and social impact assessment (*Environment Quality Act* (“EQA”) Chapter II), a transfer of the certificate of authorization (EQA Section 22) to collect a bulk sample, an authorization (EQA Section 32) for dewatering the exploration ramp and an authorization to extract a bulk sample (*Mining Act* Section 69).

In September 2019, Osisko collected a second bulk sample in the Lynx zone. This work was done after obtaining an exemption from the environmental and social impact assessment (EQA Chapter II), an authorization (EQA Section 22) to collect a bulk sample and to expand the waste rock stockpile and an authorization to extract a bulk sample (*Mining Act* Section 69).

In 2020 and 2021, Osisko obtained all authorizations to extract a third bulk sample in the Triple Lynx zone and to proceed with additional characterization work. These include exemptions from the environmental and social impact assessment (EQA Chapter II), an authorization (EQA Section 22) to collect a bulk sample and to expand the waste rock stockpile, a modification to the previous authorization (EQA Section 30) and an authorization to extract a bulk sample (*Mining Act* Section 69). The characterization work is ongoing, the Triple Lynx sample was collected in 2022, and processing and results are expected before the end of 2022.

Contact water from the stockpile and mine water are collected and treated as required. Since 2017, Osisko obtained additional authorizations to modify the process for water treatment of the effluent.

The first closure plan for the Windfall Project was prepared in 2007. As required by the *Mining Act*, the closure plan was updated after 5 years in November 2012, in June 2017, and again in January 2022. When Osisko received the authorizations to take bulk samples in the Lynx zone and later in Triple Lynx zone, two additional closure plan addendums were filed. The last addendum was approved in December 2020 with a financial guarantee requirement of \$5,601,294. The amount of the financial guarantee as detailed in the January 2022 version of the closure plan is \$11,259,086. This financial guarantee is still pending approval.



5. Accessibility, Climate, Local Resources, Infrastructure and Physiography

5.1 Accessibility

Access to the Windfall property can be achieved through the town of Lebel-sur-Quévillon. From Chantier Chibougamau's pulp mill (formerly Domtar) next to the town, the property can be reached by travelling eastbound on well-maintained, un-paved logging road R1050 (Road 1000) for about 12 km towards the former Gonzague-Langlois mine (Nyrstar) and continuing east towards the Urban-Barry area for about 55 km on R0853 (Road 5000) to the junction with R1053 (Road 6000), heading east-northeast on road R1053 for about 46 km to the main Windfall camp gravel road turnoff heading south (Figure 5-1 and Figure 5-2). The main Project zone is located about 2 km south along the main camp road. The camps, offices and core shacks are another 0.5 km south along this main road.

5.2 Local Resources and Infrastructure

The Windfall property is located in a remote area, approximately 115 km east of Lebel-sur-Quévillon. Lebel-sur-Quévillon is the closest municipality to the Project, with a population of 2,091 (Statistics Canada, 2021). The mining and forestry industries are the historical cornerstones of Lebel-sur-Quévillon's local economy.

Although Lebel-sur-Quévillon has its own small airport, Val-d'Or has the closest commercial airport with regularly scheduled direct flights to Montreal. Additionally, the communities of Senneterre, Waswanipi, Chibougamau and Chapais are also in the vicinity of the Windfall property with populations in 2021 of 2,782, 1,836, 7,233 and 1,468, respectively (Statistics Canada, 2021).

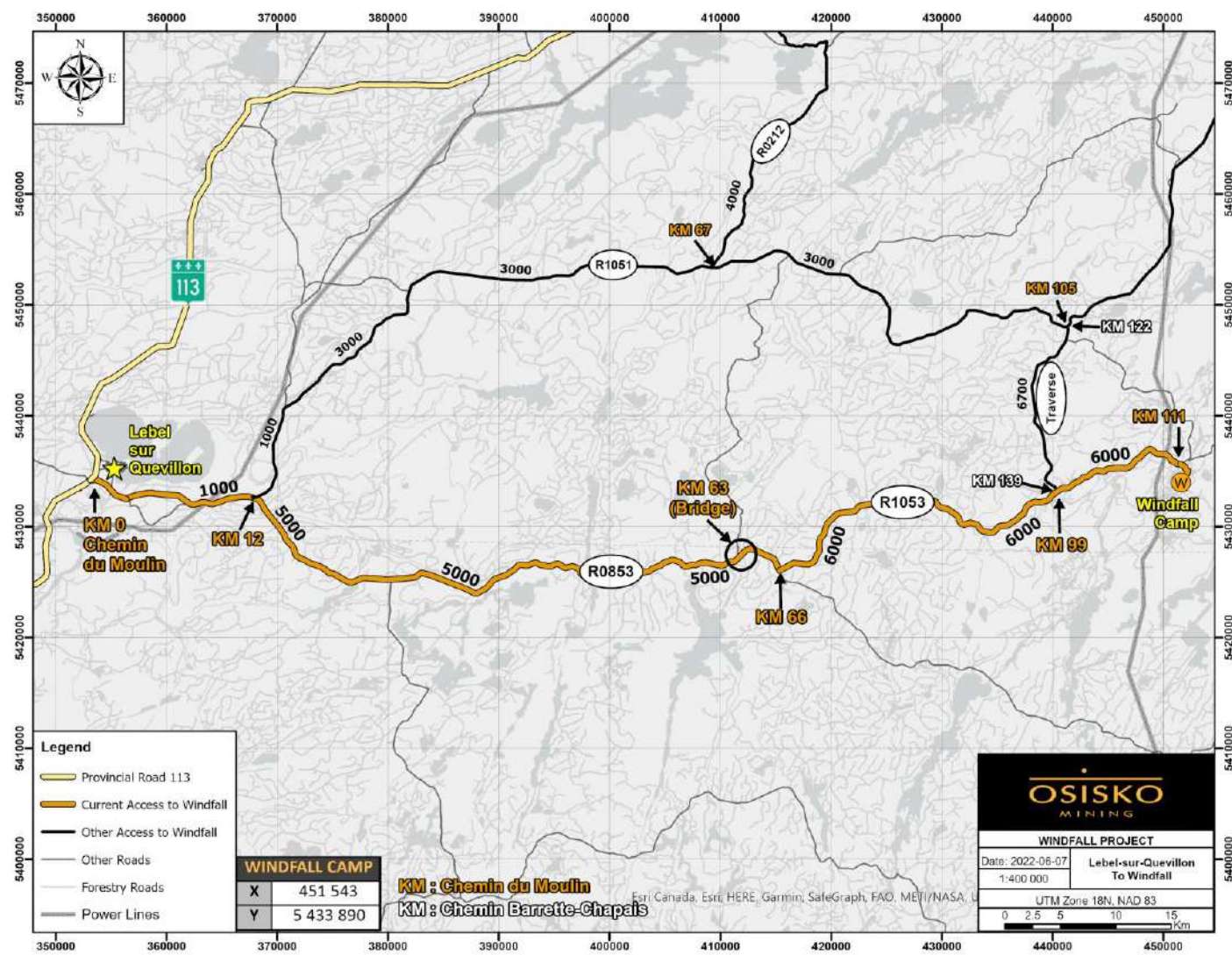

Figure 5-1: Map of the Windfall property area showing various access routes

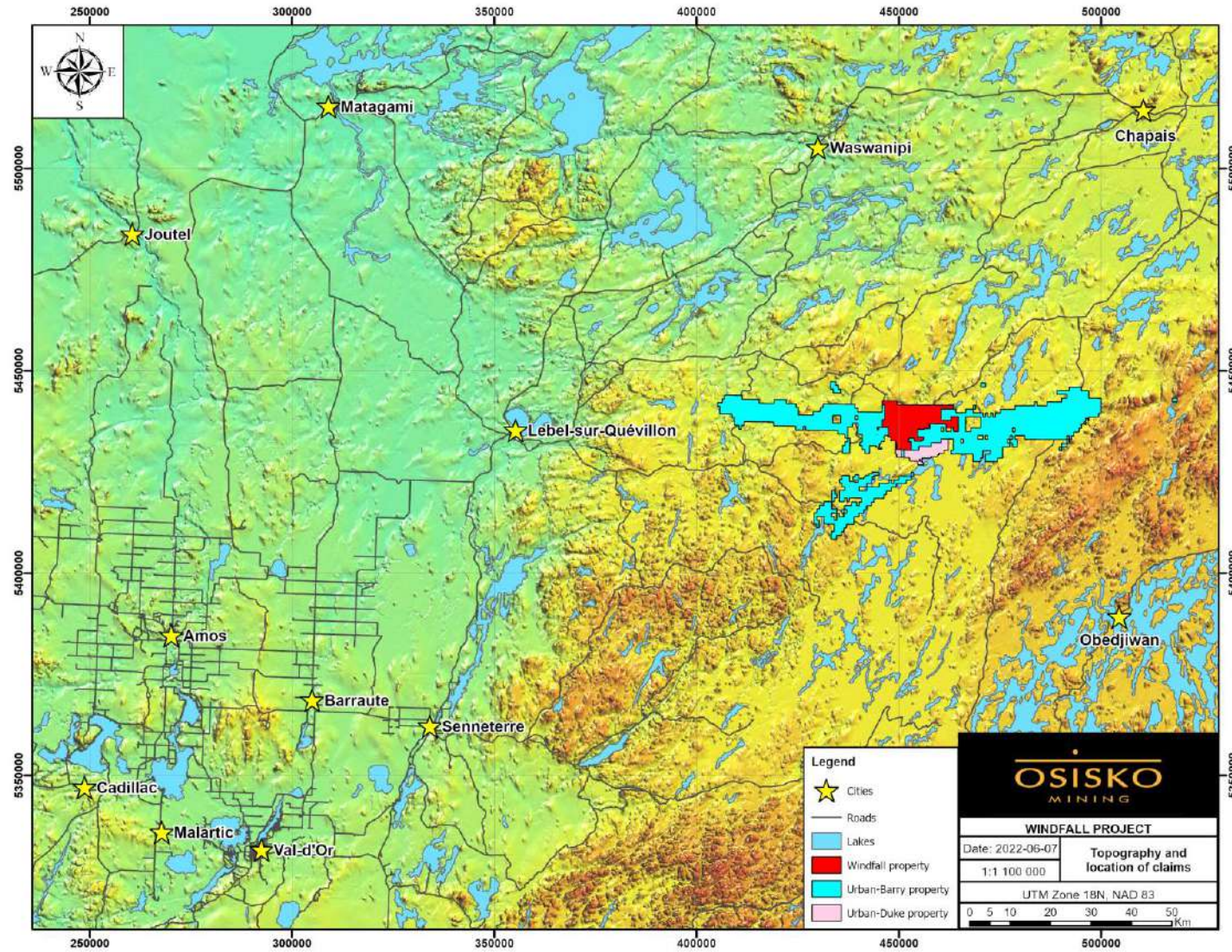

Figure 5-2: Topography and accessibility of the Windfall Project properties



Full infrastructure and an experienced mining workforce are available in several well-established mining towns nearby, such as Val-d'Or, Rouyn-Noranda, Amos, La Sarre and Matagami. Any future mining project would need to bring a skilled workforce from these surrounding communities by road or, if necessary, from elsewhere in the province, by road or chartered flight. Supplies would also have to be trucked or brought by train to Lebel-sur-Quévillon.

5.3 Climate

The Chapais 2 (Climate ID 7091305) station was taken as the base station to represent the site as it contains a long period of record, is relatively close to the site, and has a relatively similar elevation. The remainder of the regional climate stations surrounding Chapais were used to infill missing data and extend Chapais 2, resulting in a period of record that covers the years 1962 to 2021 (59 years). The details on climate analysis are provided in Golder (2022d).

The compiled climate data from the Chapais station had a relatively good data availability. However, it includes years with major data gaps (i.e., years with less than 340 days of available data) and years with minor data gaps (i.e., incomplete years with more than 340 days of available data). To achieve a continuous record of approximately 30 years for both precipitation and temperature variables, European Centre for Medium-Range Weather Forecasts (ECMWF) Re-Analysis (ERA5) was considered for infilling and extending the climate data.

Based on historical data, January is the coldest month with an average temperature of -18.4°C and July is the warmest month with an average temperature of 16.5°C. The extreme minimum air temperature was recorded at -44°C in January 2014, and the extreme maximum air temperature was recorded at 36.5°C in August 1975.

Average annual total precipitation over the baseline period was calculated to be 979.5 mm with July being the wettest month (121.0 mm) and February being the driest (42.3 mm) on average.

The potential lake evaporation was based on measured pan evaporation at the Amos (ID 7090120) station for the 1969 to 1992 period. The maximum lake evaporation of 126 mm is in July. The mean annual evaporation is 594 mm. The minimum annual calculated lake evaporation is 498 mm and the maximum annual evaporation is 660 mm.

The future projected changes to the baseline climate statistics were developed for the site based on multiple projections from multiple models and scenarios following the most recent guidelines and best practices (Golder, 2022d). Annual average temperature is projected to change by 2.9°C in the 2050s at the 50th percentile, indicating an increasing trend due to changing climate. In the 2050s, projected changes in mean monthly temperature range from 2.3°C to 4.6°C at the 50th percentile.



Annual total precipitation is projected to increase by 9% in the 2050s, indicating an upward trend in precipitation on the annual scale at the 50th percentile. In the 2050s, monthly total precipitation at the 50th percentile is projected to increase for almost all months.

With increasing temperatures due to climate change, atmospheric moisture holding capacity is anticipated to increase, thereby leading to greater magnitudes of probable maximum precipitation. In the 2050s at the 50th percentile, the 1-day, 2-day, and 3-day PMP are projected to increase by 28%, 19%, and 23%, respectively.

Projected changes in combined rainfall and snowmelt across durations and return periods range from 3% to 17% for the 2050s. Projected changes for the 1-day, 100-year event are estimated as 14% for the 2050s.

Combined rainfall and snowmelt statistics were estimated as part of the climate study (Golder, 2022d) and used in the design of water management infrastructure (see Section 18.3.23).

5.4 Physiography

The Project area is part of the Canadian Shield, characterized by topographically low-lying ridges and valleys (Figure 5-2) modified by remnants of Wisconsin aged glacial activity. The land areas are covered with boreal forests (sparse to dense tree cover) and numerous freshwater lakes, streams and muskeg (Figure 5-3).

5.5 Windfall Site

The Windfall area is serviced by a complete network of well-maintained logging roads (Figure 5-1). The primary users of the logging roads between Lebel-sur-Quévillon and the Windfall camp are workers and other exploration companies' staff in the surrounding areas.

The Windfall camp is powered by generators producing a maximum of 4 MW. They provide electricity to the surface and underground infrastructure.

Winter access to the Project site is available as the local roads are plowed. Exploration and eventual mining operation activities can be conducted year-round at Windfall.



Several infrastructure components are still present on the Project site from previous owners, including a lined stockpile containing mineralized material/waste rock. Also present are a ramp portal dating back to 2008, a collection pond, a sedimentation pond, and a polishing pond. Further south is the Windfall exploration camp, which can accommodate 300 people (Figure 5-3). The exploration camp area includes:

- Temporary trailer-type structures for gatehouse, dormitories and infirmary as well as the kitchen and the dining room;
- Waste management and recycling sorting infrastructure;
- Water treatment plant;
- Septic fields and an enviro-septic unit;
- Six separate core shacks with core racks;
- Drill core storage area (expansion in progress);
- A core cutting building;
- Drinking water wells;
- Three megadomes, one for the storage of contaminated residual materials;
- Three temporary maintenance and storage areas for diamond drilling companies and the mining contractor;
- A composting unit;
- Diesel, fuel and propane storage tanks;
- A helicopter landing area;
- Containers and sheds for storage of equipment;



Figure 5-3: Aerial photograph showing the Windfall Camp and the typical physiography of the area



The ramp (portal) sector currently includes the following facilities:

- Access roads;
- A portal and a 1,450 m ramp previously done by Noront;
- Underground exploration tunnels by Osisko totaling approximately 10,000 m;
- An overburden pile;
- A lined stockpile;
- Two sedimentation basins and a polishing basin;
- Water treatment units and geotubes;
- A garage with a concrete slab;
- An electrical substation and communication facility;
- Sanitary facilities (septic tank and associated field);
- Construction trailers for offices and dry;
- Magazines for storage of explosives and detonators;
- Fuel storage tank;
- Air compressors;
- An intake ventilation raise with heaters and propane tank;
- An exhaust ventilation raise with two fans on surface including a manway;
- Refuge stations;
- Meteorological station.

The Windfall Project contains three lease agreements, including one industrial lease agreement for the ramp area, another industrial lease agreement for the camp area and a mine waste storage lease.

The location of all potential future mining infrastructure (e.g., processing plant, tailings storage area, etc.) planned as part of this Feasibility Study is presented in Chapter 18.



5.6 Community

5.6.1 Human Environment

The Windfall Project is located in the Nord-du-Québec administrative region (Region 10). The Eeyou Istchee James Bay ("EIJB") territory includes the municipalities of Chibougamau, Chapais, Lebel-sur-Quévillon and Matagami, and the nine Cree communities of Nord-du-Québec: Chisasibi, Eastmain, Waskaganish, Wemindji, Whapmagoostui, Mistissini, Nemaska, Oujé-Bougoumou and Waswanipi. With 7,233 inhabitants, Chibougamau has the largest population in the region. Other communities include Lebel-sur-Quévillon with a population of 2,091, and Waswanipi with a population of 1,836 (Statistics Canada, 2021, 2022).

The Project is located on Category III land, that is, Crown land, part of the domain of the State, most of which is dominated by forestry activities. On this land, Crees have an exclusive right to harvest certain aquatic species and certain fur bearing animals.

For the Windfall Project, with the exception of the tallyman's family camp trapline W25B and one non-Aboriginal seasonal hunting camp, the site is characterized by the absence of dwellings. The closest residential areas are in Lebel-sur-Quévillon, Chapais and the Cree community of Waswanipi. Furthermore, there are no outfitters with exclusive rights and five outfitter camps with non-exclusive rights in a 10-km radius of the Project (MFFP, *Carte des pourvoires à droits exclusifs*, 2016).

Lebel-sur-Quévillon, just a little more than 115 km from the Windfall Project, is an urbanized area that groups together residential, public and commercial uses, a health centre, services, industrial zones and public institutions.

5.6.2 Information and Public Consultation Process

5.6.2.1 Cree Community of Waswanipi

The Windfall Project is located on the traditional lands of the Cree First Nation of Waswanipi, specifically on the trapline W25B and right next to W25A. The Cree community of Waswanipi is located about 75 km north-northwest of the Project.

Throughout the years, information on exploration work was shared with the Chief, the Deputy Chief, the Director of Natural Resources, the Mining Coordinator, the Tallymen, the Cree Trappers' Association, the Cree Mineral Exploration Board, the Cree Nation Government, and the Apatisiwin Skills Development.



Meetings were held with the tallymen to explain the nature of the work and to understand their use of the territory. Between 2017 and 2022, Osisko shared information about the proposed Windfall Project and information on the on-going drilling activities (surface and underground), surface infrastructure and the bulk sampling project towards Lynx, Underdog, Caribou and Lynx 4, and the modification of work in the Triple Lynx zone with the Cree First Nation of Waswanipi through letters, meetings, focus groups, interviews, open houses and presentations to the band council and general assemblies. This included more than 190 different meetings with Waswanipi representatives, tallymen, entrepreneurs, various organization representatives, band office employees and community members. In collaboration with the Cree First Nation, Osisko established the Waswanipi Environmental Monitoring Committee in 2019 and a COVID-19 information Sharing Committee in 2020.

Before Osisko acquired the Project, several information meetings had been held between Eagle Hill representatives and Waswanipi representatives, including former Chief Paul Gull. These meetings led to the signing in 2012 of an Advanced Exploration Agreement with the Cree First Nation of Waswanipi, the Grand Council of the Crees and the Cree Regional Authority. Osisko continues to honour the terms of the 2012 Exploration Agreement between Eagle Hill and Waswanipi. Among other things, the Agreement stipulates the negotiation of a Social and Economic Participation Agreement (essentially an impact and benefits agreement: “IBA”) in the event the Project is shown to be economically viable. Discussions are underway with Waswanipi representatives and preliminary negotiations for an IBA commenced on December 19, 2017, in Waswanipi.

Roughly about 90 people from Cree and First Nation communities (mainly Waswanipi) work at the Windfall site. More than 80 First Nation workers were on the site in 2017, approximately 55 First Nation workers in 2018, 62 in 2019, 106 in 2020 and 105 in 2021.



5.6.2.2 Communities of Lebel-sur-Quévillon, Chapais, Chibougamau and Senneterre

Osisko held various meetings and information sessions with representatives and members of local communities. In addition, information letters on exploration activities were sent to the Eeyou Istchee James Bay Regional Government. It should be noted that before Osisko acquired the Project, Eagle Hill representatives met informally with Lebel-sur-Quévillon representatives and attended an information session organized by the Economic Development Corporation of Lebel-sur-Quévillon in November 2014. Osisko presented the Windfall Project to the population in 2016, 2017 and 2018. Two Open House events were organized in Lebel-sur-Quévillon, on October 2, 2017, and February 27, 2018, to present the proposed Windfall Project to the population. In 2018, Osisko held focus groups and organized interviews with city representatives and local organizations. Since 2016, Osisko has met approximately 40 times with Lebel-sur-Quévillon representatives and/or community members to share information about the proposed Windfall Project, including information on the on-going surface drilling activities and the bulk sampling projects.

A Collaboration Agreement was signed between Osisko and the city of Lebel-sur-Quévillon in 2017. This collaborative process primarily aims to ensure transparency and effective communication with the city, foster the Project's social acceptability, and maximize the socio-economic benefits of the Project for Lebel-sur-Quévillon, all in a spirit of partnership.

As for Senneterre, Chapais and Chibougamau, even though the Windfall Project is not on their territory, stakeholders felt that local entrepreneurs could benefit from business opportunities generated by the Project.

As the Project progresses, Osisko anticipates it will adjust its communication and consultation plan, based on stakeholder's feedback, to engage both the Aboriginal and non-Aboriginal communities. The objectives of these activities will be to inform and consult with the First Nations and the public on the Project's activities, address their concerns, and collect their comments.



6. History

The Windfall and Urban-Barry properties have a long history of exploration. Details of their respective work histories are hereafter presented separately for clarity.

6.1 Windfall Property

6.1.1 Summary of Historical Work

The Windfall Project was subject to several grassroots exploration programs undertaken by various companies from the 1930s to 2020. Below is a summary of the historical work completed near the Windfall deposit (Table 6-1), as well as a map illustrating the drilling activities within the Windfall claim boundaries since 1977 (Figure 6-1). Detailed historical work descriptions can be found in previous technical reports such as Hardie et al. (2018) and Richard et al. (2021). Figure 6-1 illustrates the historical drilling undertaken within the current Windfall claim boundary. The Windfall Project has never been in commercial production.

Table 6-1: Historical exploration work in the Windfall area and significant results

Year	Company or Individual	Work Completed	Source	Report
1975 to 1977	Shell Canada	Airborne electromagnetic, prospecting, geological mapping, drilling.	Bergmann (1977) Côté (1977)	GM 32467 GM 38828
1983	Ministère des Ressources Naturelles du Québec	Airborne electromagnetic INPUT survey.	Relevés Géophysique Inc. (1983)	DP-83-08
1986	Kerr-Addison	Drilling (western part of the property; 1.31 g/t Au over 0.3 m).	Frazer (1986)	GM 45089
1987 to 1988	DeMontigny	Line cutting, ground electromagnetic (H.E.M) and magnetic surveys, geological mapping, drilling.	Gaudreault (1987) Gaudreault (1988)	GM 46103 GM 47861
1988 to 1990	Shiva Ventures	Geophysical surveys and drilling (no significant results).	Beauregard and Gaudreault (1988) Lambert (1988)	GM 48316
1996 to 1998	Murgor / Freewest Resources / Fury	Line cutting, ground mag, induced polarization, prospecting, trenching, drilling, discovery of Debris showing.	Coyle (1996) Coyle (1998) Lavoie (1996c) Feneke (1996)	GM 54544 GM 54545 GM 54546 GM 55971



Year	Company or Individual	Work Completed	Source	Report
1996 to 1998	Alto / Noront	Line cutting, ground mag, geological mapping, induced polarization, prospecting, MaxMin II, drilling discovery of Alto and Ritchot showings.	Farrel (1998) Lavoie (1996a) Lavoie (1996b) Tremblay (1999a) Tremblay (1999b) Tremblay (1999c) White (1998) Plante (1997, 1998)	GM 56245 GM 54404 GM 54405 GM 56448 GM 57412 GM 56449 GM 56450 GM 56734
1987 to 1988	Resources DeMontigny Kerr Addison Inc.	Magnetic and electromagnetic surveys, geological mapping, 15 diamond drilling (2,806.8m): ([4.0 g/t Au over 1.8 m (MUR-87-1); 4.1 g/t Au over 0.73 m (MUR-87-6); 41.4 g/t Au over 0.87 m (MUR-87-7); and 8.25 g/t Au over 0.75 m (MUR-87-14)].	Gaudreault (1987) Turcotte (1987) Lambert and Turcotte (1988)	GM 46103 GM 44547 GM 47140
1986 to 1996	Shiva Ventures, Freewest Resources Canada, and Fury Exploration	Diamond drilling on the western part of the property.		
1997	Resources Orient	Drilling (no significant results).	Chainey (1997)	GM 55698
1996 to 1999	Inmet Mining, Alto Minerals, Murgor Resources Inc.	Line cutting, IP survey, electromagnetic HEM, VLF and magnetic surveys, Pulse E.M., trenching and geological mapping. Alto drilled 34 diamond drilling (10,003 m): 27.5 g/t Au over 4.3 m. Discovery of Richtot and Alto gold showings. Murgor drilled 6 DDH (1,095 m) to the northeast of Windfall Main zone (3.47 g/t Au over 1.9 m and 15.1 g/t Au over 1.2 m).	Bernard (1999a) Bernard (1999b) Lambert (1999) Lavoie (1996a) Plante (1998)	GM 57113 GM 57413 GM 57443 GM 54734 GM 56450
2003 to 2004	Fury	Compilation, line cutting, 26 diamond drilling (7,152 M):85.9 g/t Au over 5.4 m.	Thorsen (2004)	-
2004 to 2006	Murgor Resources Inc.	IP survey, Time Domain Electro-Magnetic survey (TDEM), 115 diamond drilling (15,967 m), prospecting, and trenching. Discovery of F-17, F-51 and F-11 gold zones (16.5 g/t Au over 3.0 m, 21.7 g/t Au over 2.0 m, 16 g/t Au over 7.6 m, 44.5 g/t Au over 2.0 m).	Coyle (2005) Gagnon (2005) Gagnon (2006) Lanthier (2004 and 2005) Desrochers (2007)	GM 63038



Year	Company or Individual	Work Completed	Source	Report
2005 to 2009	Noront	Trenching, mapping, diamond drilling, underground exploration ramp and drifts (1,202 m).	Armstrong (2006) Armstrong (2007) Chance (2009a)	-
2009	Eagle Hill Exploration	Sampling historical core, trenching, channel sampling, BHPEM, IP survey.	Chance (2009b)	-
2010	Eagle Hill Exploration	BHPEM, TDEM, IP survey, 33 diamond drilling (12,648 m). Discovery of Zone 27 and Underdog zone.	Turcotte (2011)	-
2011	Eagle Hill Exploration	Mineral resource update (November 2011), IP survey, diamond drilling. Discovery of Caribou zone.	El-Rassi et al., (2011) Armstrong (2011) G&T Metallurgical Services Ltd. (2011) Desrochers (2013)	GM 68042
2012	Eagle Hill Exploration	IP survey, Till survey (49 samples), mineral resource update (March 2012), diamond drilling.	El-Rassi et al. (2012) Lambert (2012) Desrochers (2012) Desrochers (2013)	GM 68042 GM 67183
2013	Eagle Hill Exploration	Diamond drilling, hole-to-hole IP & resistivity, down hole optical and acoustic televiewer, ground magnetometer survey, surface IP survey.	Chemmanur (2013) Lambert (2014) Desrochers and Blouin (2015)	GM 69122
2014- (2015)	Eagle Hill Exploration	Diamond drilling, IP survey, mineral resource update (March 2014), Preliminary Economic Assessment (April 2015).	Simard (2014) Brown and Chemmanur (2014) Desrochers and Blouin (2015) El-Rassi et al. (2014) McLaughlin et al. (2015)	GM 69122

“GM” (or gîte minier) = geological assessment report.

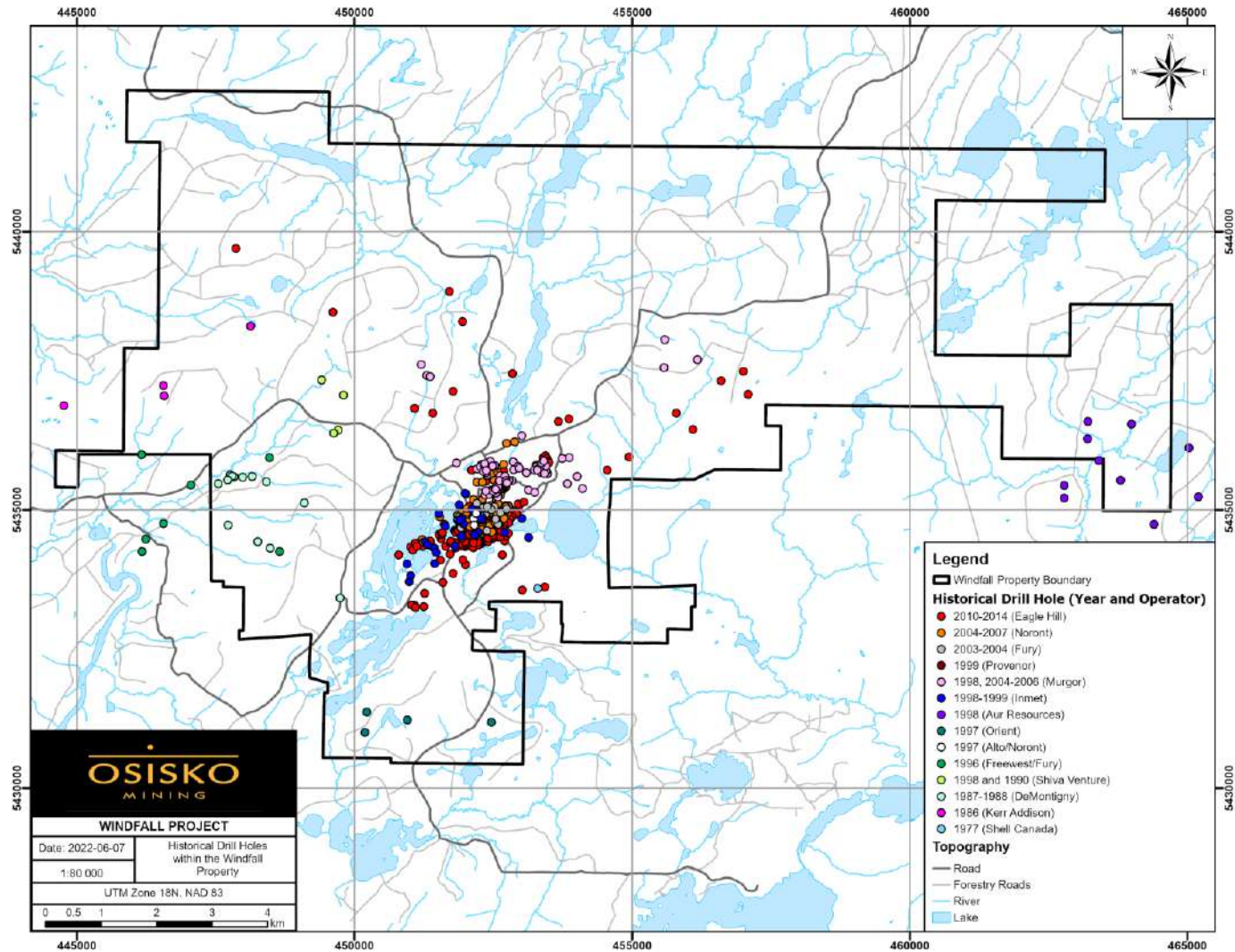

Figure 6-1: Historical drill holes categorized by company within the Windfall property



6.1.2 Mineral Resource Estimates

Between 2011 and April 2015 Eagle Hill Exploration Corporation mandated three NI 43-101-compliant mineral resource estimates from SRK Consulting (Canada) Inc. (El-Rassi et al., 2011; 2012; and 2014). In 2018, Osisko contracted InnovExplo for a new NI 43-101 on the Windfall deposit (St-Laurent et al., 2018). The supporting technical reports are available from SEDAR (sedar.com).

In 2015, Tetra Tech produced a preliminary economic report with an effective date of April 28, 2015, herein also referred to as the PEA, for Eagle Hill Exploration Corporation (McLaughlin et al., 2015) in which SRK reviewed the mineral resource estimate in November 2014. The PEA also proposed mineral processing and metallurgical testing recovery methods and addressed the surface water management, tailings storage and the project's environmental aspects.

In 2018, BBA Inc. completed a PEA, with an effective date of July 12, 2018, for Osisko (Hardie et al., 2018), which included the Windfall deposit and the Osborne-Bell deposit. The PEA also proposed mineral processing and metallurgical testing recovery methods and addressed the project's tailings, waste, and water management. The 2018 PEA relied on both the 2018 Windfall and Osborne-Bell deposits NI 43-101 reports.

In early 2020, Osisko mandated a NI 43-101 compliant mineral resource estimate from Micon International Ltd. (Murahwi and Torrealba, 2020).

In early 2021, BBA Inc. completed a PEA based on Measured, Indicated, and Inferred Mineral Resource estimates, which is described in the NI 43-101 compliant mineral resource estimate report titled "Mineral Resource Estimate Update for the Windfall Project, Eeyou Istchee James Bay, Québec, Canada" (effective date November 30, 2020; Richard et al., 2021).

In early 2022, BBA Inc. completed an MRE update, which is described in the NI 43-101 compliant mineral resource estimate report titled "Mineral Resource Estimate Update for the Windfall Project, Eeyou Istchee James Bay, Québec, Canada" (effective date October 20, 2021; Richard and Bélisle, 2022).

The estimates in the current technical report supersede all previous mineral resource estimates. The QP has not verified the results of previous estimates, and they are not presented here.



6.2 Urban-Barry Property (Western, Central, Eastern and Southern Sectors)

6.2.1 Previous Work

The exploration history of the Urban-Barry property outside of the Windfall deposit area is subdivided into four different sectors: West, East, Central and South (Figure 6-2). Most of the exploration work was performed in the Souart, Barry and Urban Townships. The Urban-Barry belt is host to numerous gold deposits/showings that include the Souart (Nubar) (Osisko), Barry (Bonterra Resources, formerly Métanor Resources), Windfall (Osisko), Lac Rouleau (Osisko, formerly Beaufield Resources) and Gladiator (Bonterra Resources) deposits.

The Urban-Barry greenstone belt has been, in recent years, the subject of several regional mapping surveys performed by the Québec government. The entirety of the belt was covered by 1:50,000 scale mapping from 2001 to 2004. The western area was mapped in 2002 (RG200212), the Windfall claims and the Southern portion in 2001 (RG200114) the central and eastern sectors in 2003 (RG200307), and the southeastern limit of the belt in 2004 (RG200402).

Over 300 geological assessment reports (*gîte minier* or GM) are on file with the Québec government that describes historical exploration work done partly or entirely within the bounds of the current Urban-Barry property. Various companies have conducted prospecting campaigns and secondary environment surveys over the years, but due to the general lack of outcrop, exploration has tended to rely upon geophysics to define targets. Except for the northernmost part, most of the Urban-Barry belt has been covered by airborne surveys. These included MAG, EM, VLF-EM, and more recently, VTEM surveys. A few companies also re-interpreted the INPUT data from government surveys to generate targets. The most extensive airborne surveys on file with the government were carried out by Shell Canada Resources Ltd. in the mid-seventies. Ground geophysics such as IP, MAG, VLF and other EM surveys usually followed.

Table 6-2 summarizes the historical work completed within the Urban-Barry claim boundaries and Figure 6-2 illustrates the drilling activities within the Urban-Barry claim boundaries.

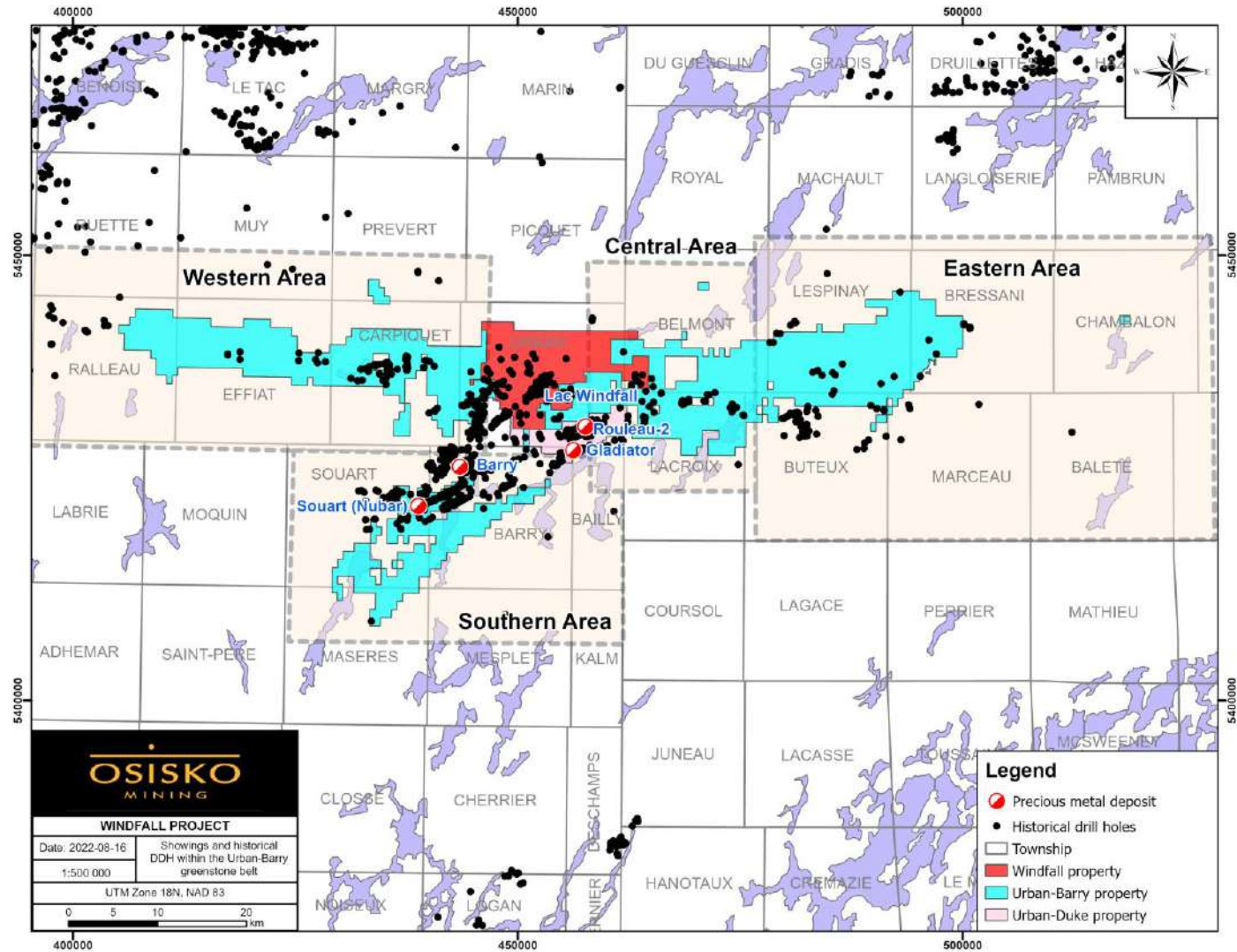

Figure 6-2: Exploration history in the Urban-Barry Greenstone Belt outside of the Windfall deposit area, subdivided into four sectors: Eastern, Southern, Central and Western areas



Table 6-2: Historical exploration work in the Urban-Barry area and significant results

Area	Year	Company or Individual	Work Completed	Report
Western Block	1957	Merrill Island Mining Corp.	13 DDH; Discovery of the Lac Thubière NE gold showing.	GM 05817-B
	1959-1969	Nightlen Mines; Falconbridge	2 DDH (6 km east of Lac Thubière showing). No significant values. Falconbridge drilled 4 holes 2.5 km southwest of the Lac Thubière NE showing and reported minor chalcopyrite and sphalerite.	GM 10409 GM 24493
	1986	Mines Sullivan Inc.	26 DDH to the south and west of Lac Thubière NE showing (grab samples ranged from 1.13 to 9.07 g/t Au on the showing).	GM 45086
	1987-1988	Cambior	6 DDH (1,300 m) – no significant results.	GM 47783
Central Block	1983	Mines Camchib Inc.	6 DDH – no significant results.	GM 41498
	1989	Joint Venture-Beaufield Resources Inc. and Falconbridge Ltd.	Horizontal loop electromagnetic survey (100.2 km); Magnetic survey (114 km); 5 DDH (900 m) to the southwest of Lac Chanceux SW showing. These holes encountered graphite and iron sulphide and returned mostly trace gold values and a few values up to 100 ppb gold in drill hole 104-05.	GM 49193
	1997	Kinross Gold and Beaufield	7 DDH (Lac Chanceux Ouest showing returned 1.384 g/t Au over 0.81 m).	GM 56118
	1998	Aur Resources	10 DDH – 1.7 g/t Au over 0.7 m.	GM 57568
	2004	Beaufield Resources	11 DDH southwest of Belmont showing - 11.63g/t Au over 3.73m; 7.65g/t Au over 4.05m).	GM 61527
Eastern Block	1977	Shell Canada Resources Ltd.	25 DDH (2,485 m) – 362 g/t Au over 1.78 cm in a quartz veins in banded pyrrhotite-arsenopyrite-pyrite zone.	GM 38828
	1987-1989	SOQUEM	Diamond drilling and prospecting – A sample in drill hole 87-9 returned 0.55 g/t Au. A grab sample 80 m returned 4.11 g/t Au from a sheared and silicified zone. Resampling of hole 7515-77-16 (Côté, 1977) returned 6.5 g/t Au over 1 m. Prospecting (1989) returned 1.08 g/t Au and 1.91% Cu in a shear breccia zone.	GM 48455 GM 46447



Area	Year	Company or Individual	Work Completed	Report
Southern Block	1950	Roybarn Uranium and Gold Mines Ltd.	Discovery of the Souart (Nubar) deposit following a resistivity survey. Underground development (abandoned in 1951).	GM 00910
	1975-1978	Shell Canada Resources Ltd.	Geological mapping, geochemical and geophysical surveys. Discovery of numerous polymetallic showings.	GM 33284 GM 33665
	1985-1988	Oasis Resources Inc.	25 DDH (6,096 m) in 3 mineral zones on their Souart (Nubar) deposit; IP survey.	GM 47768 GM 42923
	1988-1989	Société d'Exploration Minière Dufresnoy Inc.	11 DDH (2,123.9 m) northeast of the Souart (Nubar) deposit (5.15 g/t Au and 28 g/t Ag over 1 m). A total of 28 drill hole intersections had more than 1 g/t Au.	GM 49423



7. Geological Setting and Mineralization

This chapter presents a description of the geological setting and the gold mineralized zones at the Windfall Project. The information presented in this section was taken from: 1) internal geological reports and studies; 2) regional geological reports from the Québec Ministry of Energy and Natural Resources (“MERN”) (Joly, 1990; Bandyayera et al., 2002a, b; Rhéaume and Bandyayera, 2006); and 3) from an unpublished M.Sc. thesis that described and documented various aspects of the geology at the Windfall gold deposit (Choquette, 2021).

7.1. Regional Geology

The Windfall and Urban-Barry properties are located in the eastern part of the Northern Volcanic Zone (“NVZ”) of the Abitibi Subprovince, which is part of the Archean Superior Province (Figure 7-1). The Urban-Barry greenstone belt has an east-west extent of 135 km and is 4 km to 20 km wide. It is bounded to the north by the Father plutonic suite, to the east by the Proterozoic Grenville province, to the south by granitoid and paragneiss rocks of the Barry Complex, and to the west by syn- to late-tectonic granitoid rocks of the Corriveau and Souart Plutons (Figure 7-2).

Rocks of the Urban-Barry greenstone belt are generally metamorphosed to greenschist facies, although near large granitoid intrusions and within corridors of intense deformation, conditions locally reached amphibolite facies. The regional metamorphic temperature-pressure gradient generally increases eastward towards the Grenville Front (Joly, 1990).

7.2. Windfall and Urban-Barry Properties

7.2.1. Local Geology

The Urban-Barry greenstone belt contains mixed mafic- to felsic volcanic rocks with lesser sedimentary deposits that are cross-cut by several east- and east-northeast trending deformation zones (Figure 7-2). The Windfall property is located along the Mazères deformation zone, which is a regional-scale east-northeast trending ductile deformation zone that is interpreted to be a second-order structure to the east-west trending Urban deformation zone.

The Urban-Barry belt is informally divided into five rock formations constrained between 2791 to 2707 Ma (Rhéaume and Bandyayera, 2006), including: 1) the Fecteau (2791 Ma); 2) the Lacroix (undated); 3) the Chanceux (2727 Ma); 4) the Macho (2717 Ma); and 5) the Urban (2714 to 2707 Ma) formations. The Windfall deposit is hosted in the Macho formation, which contains two distinct lithostratigraphic sequences: the Rouleau member and the younger Windfall member (2716.9 ± 2 Ma). The older Rouleau member is comprised of: 1) calc-alkaline- to transitional andesite to



andesite-basalt lapilli tuffs; 2) tholeiitic basalts; and 3) mudstones. The younger Windfall member is comprised of: 1) calc-alkaline dacite, rhyodacite and trachyandesite; 2) tholeiitic felsic tuffs and lavas; 3) tholeiitic- to transitional andesite porphyries and tuffs; and 4) minor iron formation (Bandyayera et al., 2002a, Rhéaume and Bandyayera, 2006). In the Windfall deposit area, this stratigraphy dominantly strikes northeast and dips moderately towards the southeast.

On the Windfall property, the volcano-sedimentary sequence is cut by a series of younger quartz-feldspar porphyry (“QFP”) dikes and stocks. U-Pb zircon dating of pre- and post-mineral QFP intrusions constrain their emplacement to 2698 ± 3 Ma and 2697.6 ± 0.4 Ma, respectively (Davis 2016, unpublished). These intrusions also constrain the timing of the main Au event at the Windfall deposit to have occurred between a maximum of 2701 to 2697.2 Ma (Choquette, 2021).

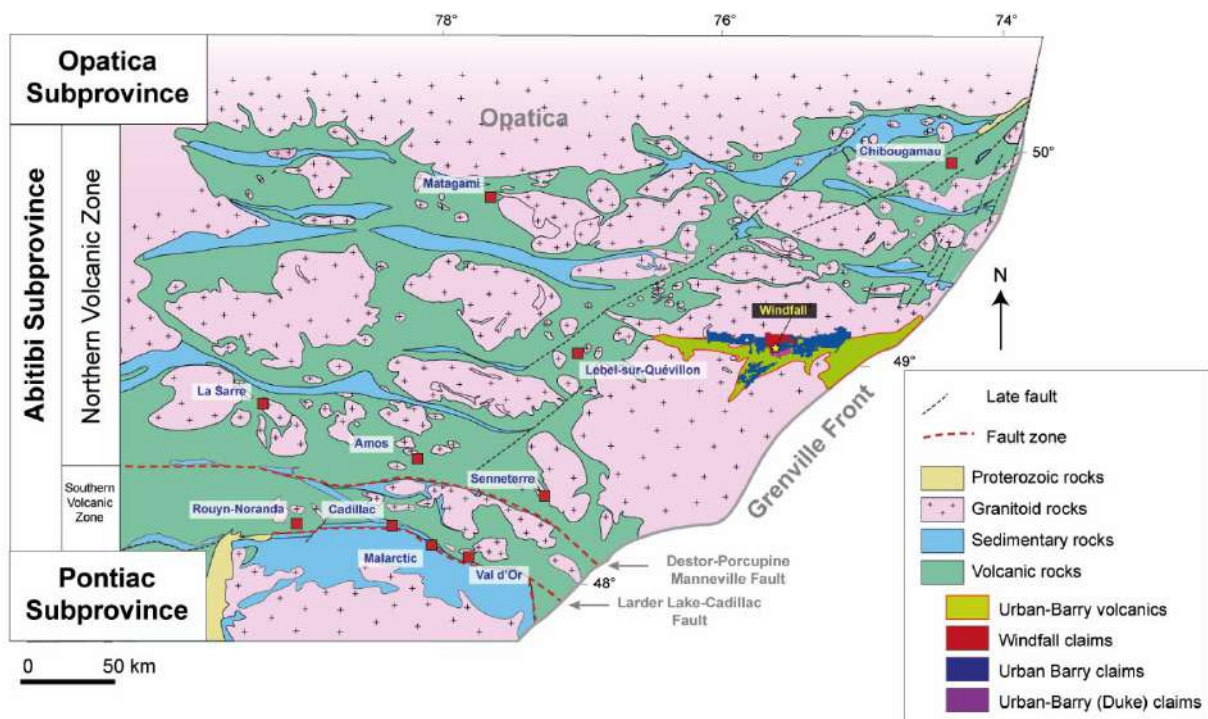

Figure 7-1: Simplified geology map of the Archean Abitibi Subprovince and the locations of the Windfall and Urban-Barry properties
The yellow star indicates the location of the Windfall deposit.
Modified from Chown et al. (1992), Daigneault et al. (2002) and Daigneault et al. (2004)

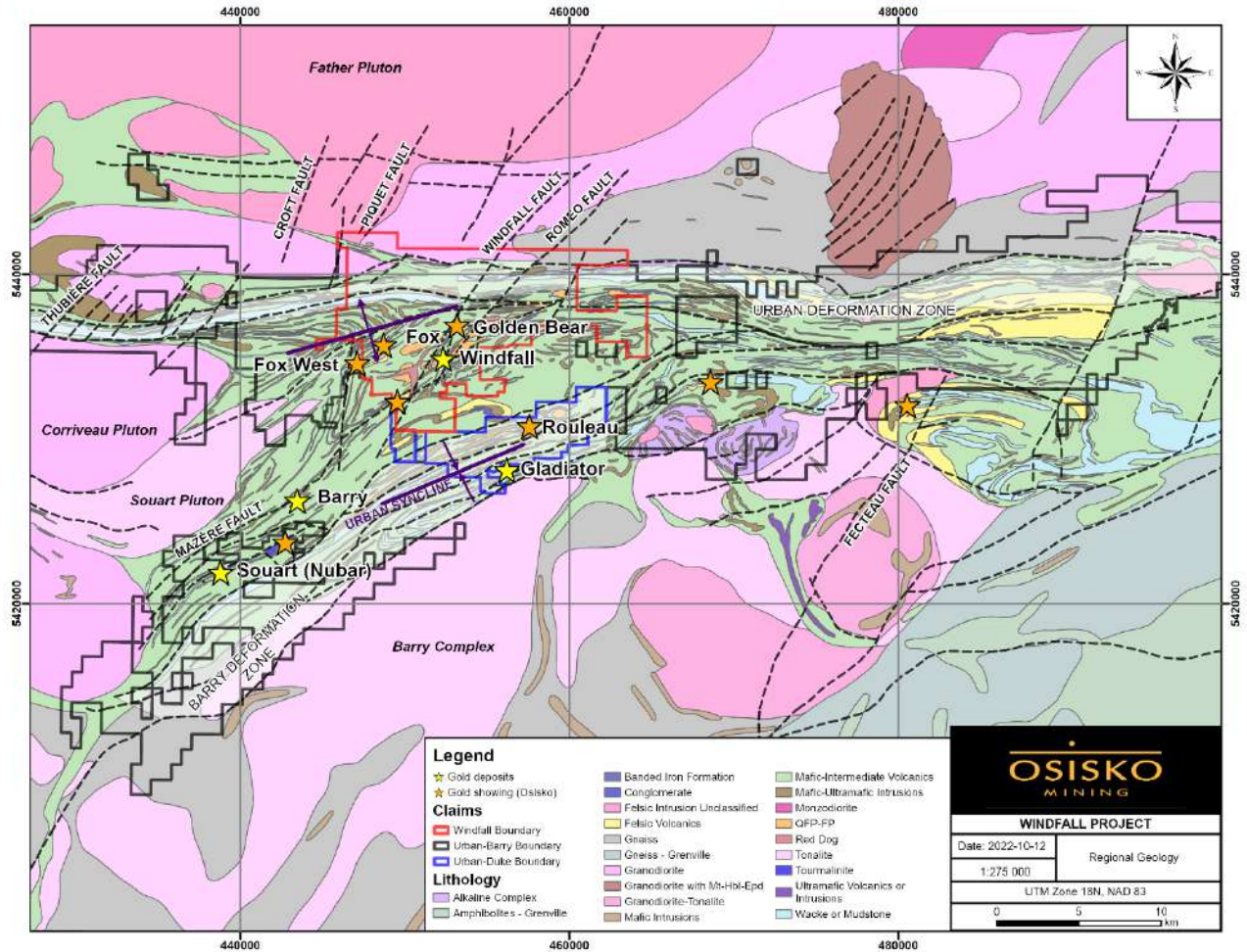

Figure 7-2: Regional geologic map of the Urban-Barry greenstone belt and the location of the Windfall, Urban-Barry and Urban-Barry (Duke) claim boundaries
 The yellow stars indicate the locations of the main gold deposits and the orange stars indicate the locations of the Fox, Fox West, Golden Bear, and Rouleau gold showings.
 Geology map is modified after Bandyayera et al. (2002)

7.2.2. Windfall Property Geology

In the Windfall deposit area, the volcanic stratigraphy dominantly strikes north and dips moderately towards the east and consists of a bimodal sequence composed of texturally variable basalt, andesite, rhyolite and minor horizons of mudstone belonging to the Windfall member of the Macho formation (2716.9 ± 2 Ma). This bimodal sequence of volcanic rocks is intruded by: 1) tholeiitic gabbro intrusions; and 2) a series of calc-alkaline granodiorite-granite quartz-feldspar porphyry dikes, herein referred to as QFP dikes. The two magmatic intrusive suites (i.e., tholeiitic



gabbro and calc-alkaline granodiorites-granites) are contemporaneous based on cross-cutting relationships and center on ca. 2698 Ma. Seven texturally distinct QFP dikes are observed to cross-cut the volcanic strata at high angles. The dikes are divided into three main groups based on several criteria: texture, colour, size and abundance of quartz phenocrysts, orientation, and timing with respect to gold mineralization. From youngest to oldest, these groups are: 1) fragmental and small quartz eye QFPs; 2) large quartz eye QFPs; and 3) post-mineral hematite altered QFPs.

The pre-mineral QFPs dominantly strike ENE, are sub-vertical and plunge 35° towards the east-northeast. They are overprinted by gold mineralization and associated hydrothermal alteration. The post-mineral QFPs strike north and dip 35° towards the east-northeast. The post-mineral QFPs cross-cut gold mineralization as observed in outcrop, underground exposures, and in drill core.

All dikes and volcanic rocks are affected by the regional foliation (S_2). The intensity of the foliation and the overall strain vary greatly within individual rock units and the alteration and mineralization are overprinted by this fabric (S_2).

7.3. Alteration

The nature, distribution, and intensity of the alteration in the Windfall deposit is mainly controlled by the composition of the host rocks and their proximity to gold-mineralized zones. Several alteration minerals are observed throughout the deposit and mainly consist of sericite, silica, chlorite, carbonate, tourmaline, pyrite, fuchsite, and locally biotite alteration at greater depth. The most significant alteration observed is a proximal assemblage which is associated to the gold mineralization.

This proximal assemblage consists of sericite-silica-pyrite ± tourmaline ± fuchsite ± carbonate with pyrite averaging 1-10 % as disseminations. Where most prevalent, it has a strong correlation with high Au grades and is commonly referred to as replacement-type mineralization. In drill core, it varies from a few centimetres to several metres in thickness and is heavily influenced by host-rock composition. Intermediate- to mafic rocks (e.g., andesite, basalt, gabbro) are bleached to a light grey-green colour, have a moderate- to strongly developed pervasive sericite-pyrite assemblage with a local pervasive to patchy silicification. More restricted is fuchsite, which is seen as a pervasive or spotted alteration when mineralization is hosted in or immediately proximal (i.e., generally <5 m) to gabbro or ultramafic intrusions. Felsic rocks (i.e., rhyolite, QFP dikes) are beige to light grey with the development of pervasive sericite-pyrite and locally patchy to pervasive silicification. Representative alteration styles observed in drill core are illustrated in Figure 7-3.



Figure 7-3: Examples of the proximal alteration assemblages observed in drill core at the Windfall deposit
V1 = felsic volcanics; V2 = intermediate volcanics; I3A = gabbro intrusion



7.4. Structural Geology

Major and minor structures are observed to cross-cut the Windfall property as identified by observations made in drill core, underground exposures, and surface trenches. These observations are supported by interpretations of major and minor lineaments in both ground and airborne geophysics (magnetic, gradient EM and IP surveys). Extensive drilling and subsequent core logging, mapping, and modelling have identified the most significant structures that cross-cut the property and a robust database of oriented structural measurements from drill core ($n = 225,000$) help to interpret the structural features observed.

Three major regional deformation events are observed to have affected the Windfall deposit and are simply denoted as D_1 - D_3 . These include: 1) folding (D_1); 2) north to east-northeast trending faults, shear zones and tectonic fabric (D_2); and 3) late north-trending brittle faulting (D_3). Also, at the deposit scale prior to the D_1 deformation event, a period of extension is interpreted to have occurred during the emplacement of the pre- and post-mineral QFP dike complex. Extensional structures formed during this event controlled the emplacement of gold mineralization. These structures are discussed in more detail below.

Following the formation of the volcanic sequences of the Urban-Barry greenstone belt (youngest dated at 2707 ± 3.2 Ma), the volcanic rocks are cross-cut by pre-mineral QFP dikes and stocks that are dated at ca. 2698 Ma. These intrusions are emplaced in extensional structures that are oriented: 1) north-striking dipping 30 - 50° east; 2) east-northeast-striking dipping 70 - 80° southeast; and 3) west-northwest-striking dipping 70 - 90° north (Figure 7-4). Following the emplacement of the pre-mineral QFPs, vein- and replacement-type gold mineralization (described below) are emplaced in extensive networks of faults and fractures that mimic the orientations of the pre-mineral QFP dikes (Figure 7-4).

The Windfall deposit is then folded by a D_1 deformation event that affects the entire deposit, including the post-mineral QFPs. The fold is characterized by regional scale open to tight folds with axial planes that trend east-northeast and plunge roughly 35° to 40° . No fabric associated with this folding event has been identified. At the Windfall deposit, the fold has open synform geometry that plunges 35° towards the east-northeast. The fold is readily visualized by the synform shape of the pre-mineral gabbro intrusion, and the post-mineral hematite altered granodiorite (i.e., I13) observed in Figure 7-4 and Figure 7-9.



The D_2 deformation event is subdivided into two deformation episodes that are considered to be part of the same progressive deformation event. The D_{2a} event is associated with the formation of a penetrative fabric (S_2) that strikes north to northwest and dips 30-50° east to northeast. The S_2 fabric is associated with an L_2 stretching lineation that plunges 30-60° towards the east. The S_2 fabric is observed throughout the deposit (Figure 7-4). Overall, this fabric is generally weak in intensity, but where it overprints areas of syn-mineral alteration (i.e., sericite-pyrite) the fabric is more prominent. This fabric locally transposes the vein- and replacement-type mineralization, but overall, its effect on the gold mineralized zones is interpreted to be minimal.

Progressive deformation leads to the formation of D_{2b} structures that are associated to the Bank fault (i.e., Mazères deformation zone). The Bank fault is a 100-200-m wide corridor of intense ductile deformation expressed as a reverse sinistral fault-shear zone with an unmeasured distance of displacement (may be upwards of a 1-2 km). The Bank fault cross-cuts and deforms the rocks of the Windfall deposit and is responsible for the folding of the S_2 fabric into an east-northeast orientation. The Windfall deposit is located in the footwall of this structure, whereas the hanging wall is characterized by a gold-barren sequence of strongly deformed mafic volcanic rocks. The volcanic rocks, the pre- and post-mineral QFP dike rocks, the vein- and replacement-type gold mineralization, and the north-trending tectonic fabric (S_2) are observed to be drag folded parallel to this structure within 50 m of the immediate footwall in the Lynx area.

The D_3 deformation is defined by late brittle faults that overprint all lithologies, shear zones and gold mineralization. These late brittle structures are observed in drill core and underground exposures and are characterized by zones of broken core, fault gouge and cohesive fault breccias. These faults are steep to moderate dipping structures that strike north-northeast (Figure 7-4). The Windfall fault and the Romeo fault are part of the D_3 fault system and are easily mapped using various geological logging codes and rock quality designation ("RQD") values.

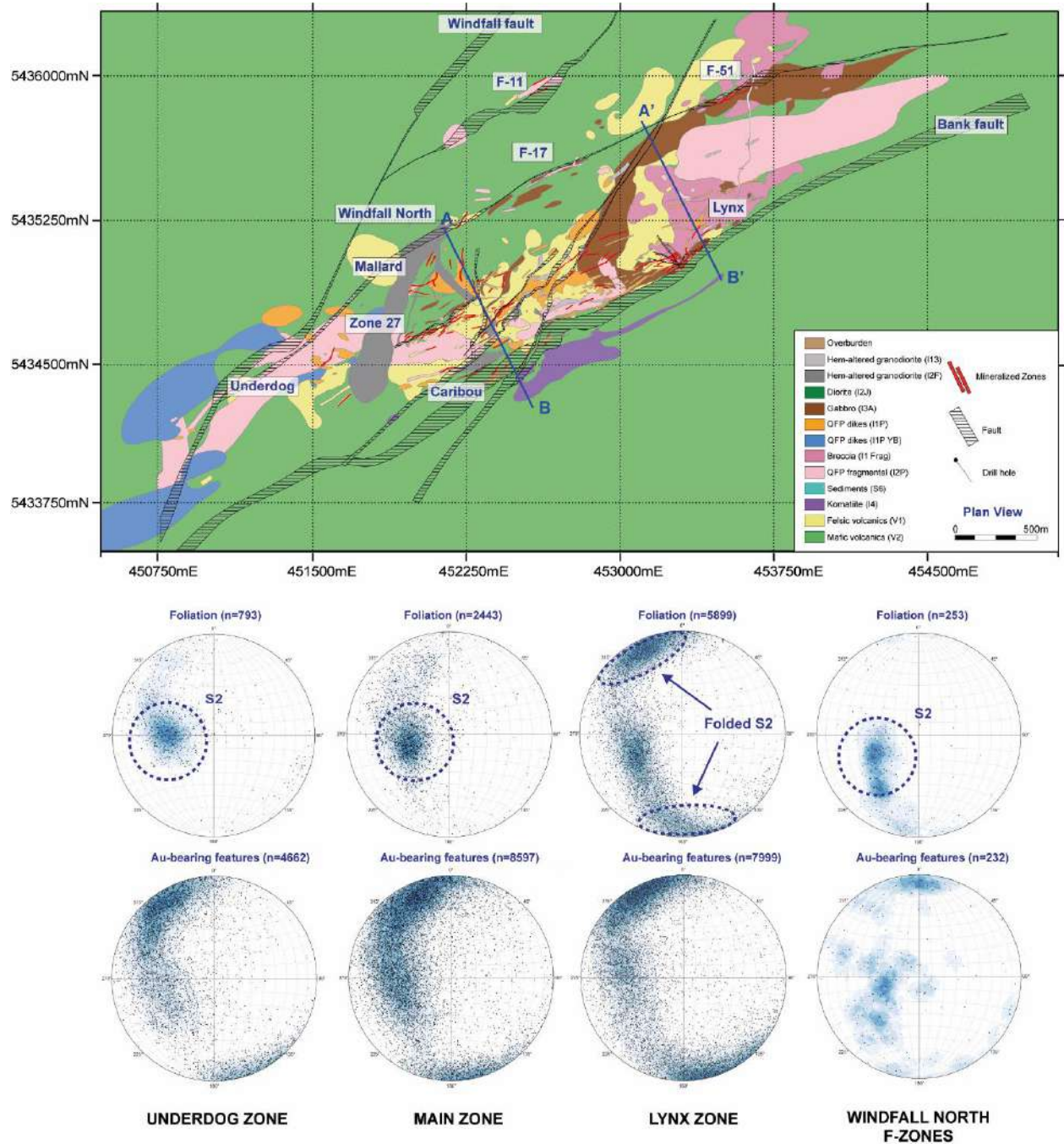

Figure 7-4: Interpreted surface geology of the Windfall gold deposit
 With modelled mineralized lenses (red polygons) and lithologies (elevation 235 m). Stereonet projections of the orientation of contacts of pre-mineral QFPs, gold-bearing features (i.e., Qtz-Py veins and Py veinlets), and schistosity from oriented drill core structural measurements within individual mineralized zones. Refer to Figure 7-9 and Figure 7-10 for vertical cross-sections (A' - B' Lynx zone) and (A - B Main zone), respectively.



7.5. Mineralization Styles and Relative Timing

Two dominant styles of gold mineralization are observed in the Windfall deposit, and these are a vein-type and replacement-type mineralization. In addition to this, numerous remobilized gold veins cross-cut these features.

Vein-type mineralization consists of grey to translucent coloured quartz veins that contain pyrite and subordinate amounts of carbonate, tourmaline and commonly visible gold (Figure 7-5a-e). The veins have sharp contacts that are either straight or folded. Texturally these veins are massive, vary in thickness from 0.1 m to 1 m, and are generally associated with the highest gold grades ranging on average from 20 g/t to >100 g/t. In the veins, sulphide content ranges from 1% to 80% and is dominated by pyrite with minor concentrations (<1% total sulphide) of chalcopyrite, sphalerite, arsenopyrite, galena, pyrrhotite, tennantite and other Bismuth-Tellurides minerals, as identified by internal petrographic and microanalytical analyses. This mineralization style is the dominant type in the felsic volcanic and intrusive dominated domains of the deposit (i.e., Caribou, Underdog and Lynx).

Replacement-type mineralization occurs at the margins of vein-type mineralization or in highly altered zones that lack the development of quartz veins. This mineralization style consists of corridors of pyrite replacement zones and stockworks associated with a strong pervasive silica-sericite \pm tourmaline \pm carbonate alteration of the host rock (Figure 7-5f, g). The gangue and mineralization-related metals are identical to those mentioned above in the vein-type mineralization. The gold is associated with pyrite occurring as disseminations or stockworks, which vary from 1 to 80 volume % of the mineralized intervals. This mineralization style is the dominant type in the mafic-intermediate volcanic dominated domains of the deposit (i.e., Zone 27, Triple 8).

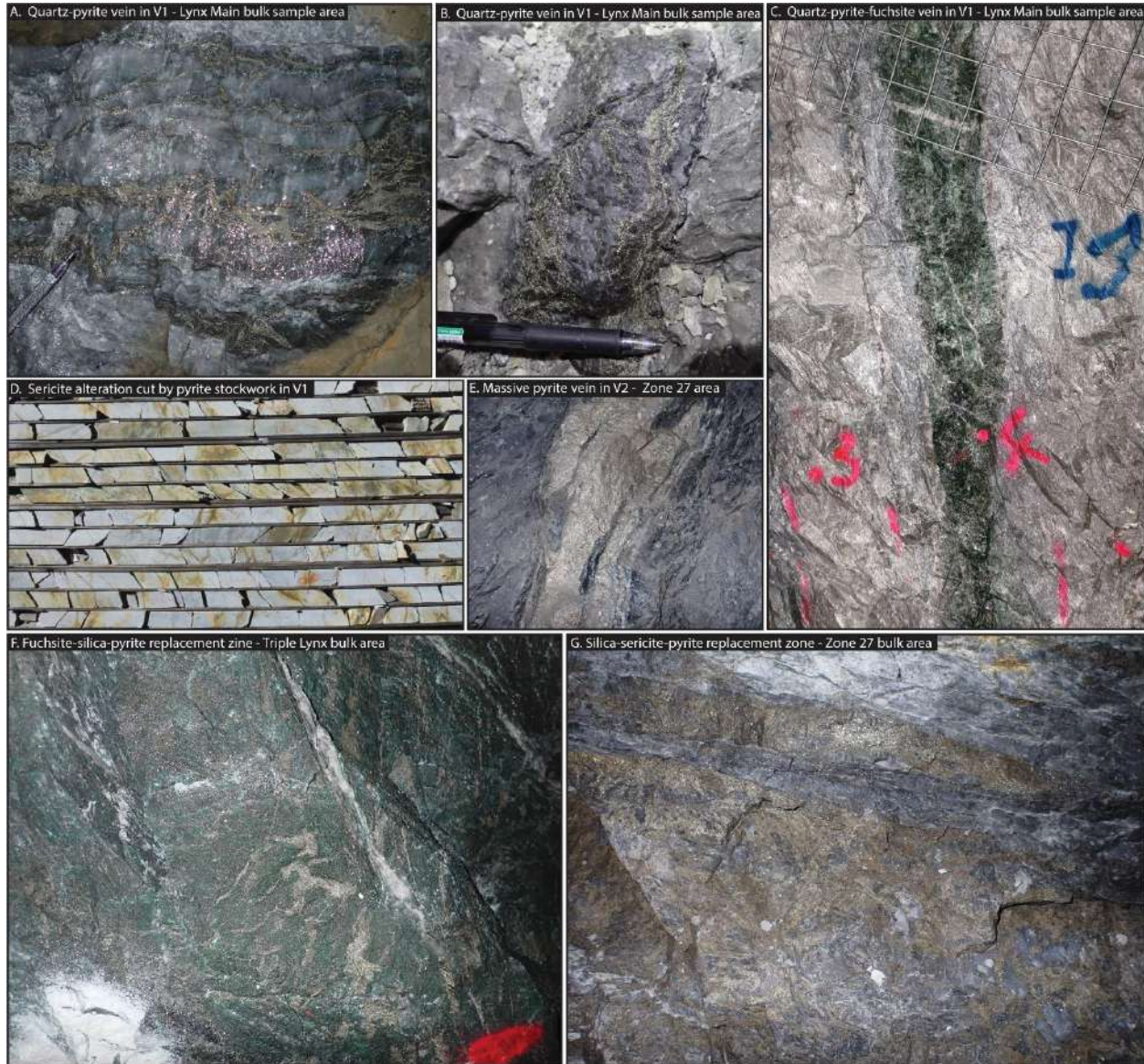

Figure 7-5: Main types of mineralization observed at the Windfall deposit
Examples of vein-type mineralization (A-E) and examples of replacement-type mineralization (F-G)



The occurrence of high-grade gold intersections with spectacular visible gold is a well-documented phenomenon at the Windfall deposit. This visible gold has been observed in both drill core and underground exposures and is hosted in the vein-type mineralization or in the zones of very intense silicification. Such occurrences have variable amounts of modal gold (i.e., >10s to 1,000s g/t) that are hosted in cloudy white quartz-carbonate that overprints the earlier vein- and replacement-type mineralization (Figure 7-6). The visible gold is a discordant feature, but it is restricted to the vein- and replacement-type gold mineralized zones and is interpreted to reflect a local internal remobilization of metals during a later deformation event. This interpretation is supported by 1,000s of visible gold intercepts that are always located within the vein- and replacement-type mineralization.

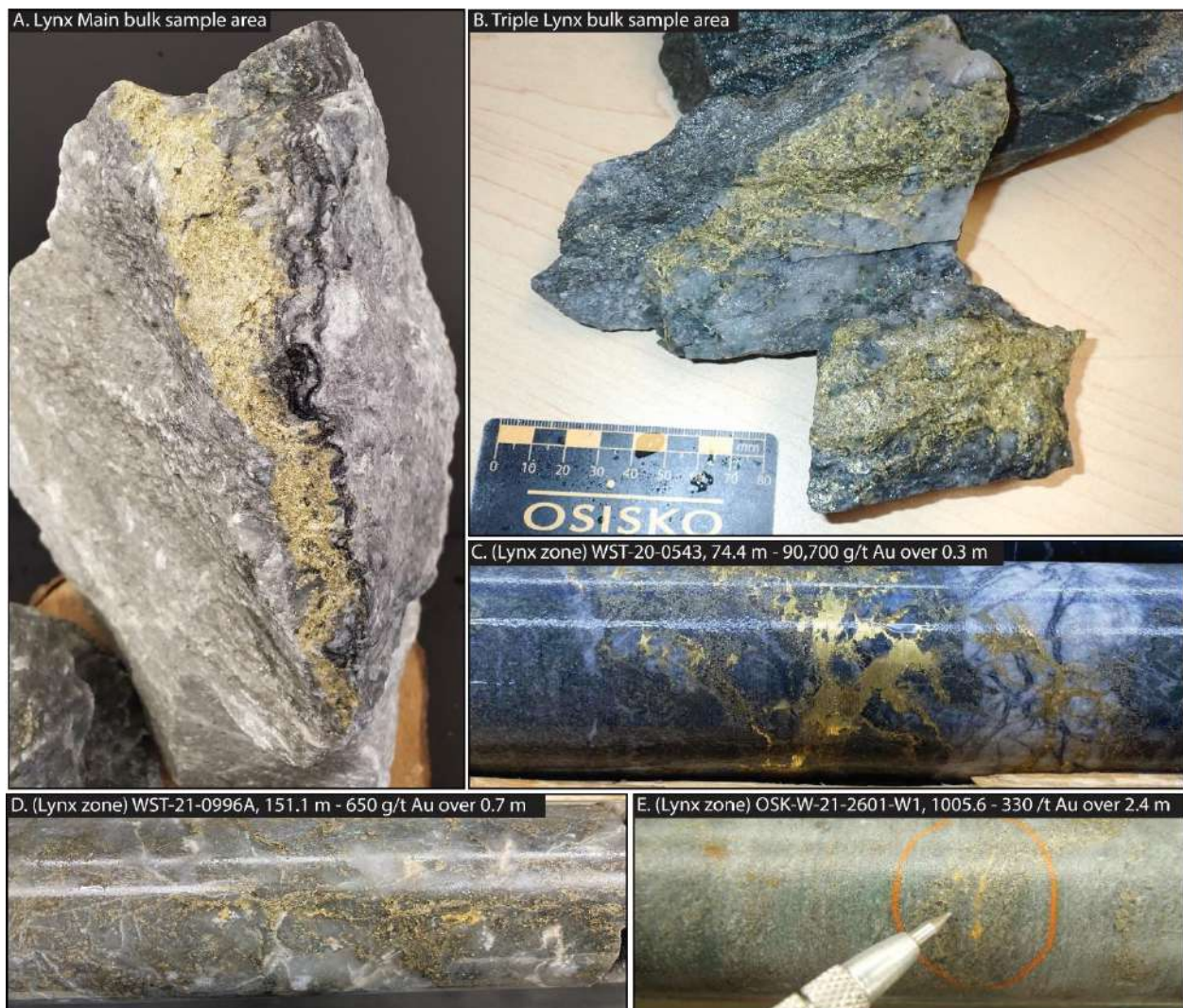

Figure 7-6: Representative images of visible gold observed in vein-type (A-D) and replacement-type (E) mineralization at the Windfall deposit



Other than the auriferous vein- and replacement-type mineralization noted above, less significant vein-types include: 1) gold-barren carbonate-quartz veins with colloform textures (pre-mineral); 2) gold-barren sheeted blue quartz veins (pre-mineral); 3) fault-related quartz-carbonate-tourmaline veins and tourmaline breccias (post-mineral); 4) carbonate-quartz stockworks and breccias (post-mineral); and 5) late white to grey quartz veins with coarse pyrite and rare remobilized gold (post-mineral).

The relative timing of gold mineralization is well constrained by the age of the pre- and post-mineral QFP intrusions. The zircon ages of 2698 ± 3 Ma for a pre-mineral QFP and 2697.6 ± 0.4 Ma for a post-mineral QFP (i.e., Red Dog) constrain both the time and duration of magmatism from 2701 to 2697.2 Ma and also brackets the main Au event to this interval.

7.6. Mineralized Zones

At the Windfall deposit, the high-grade gold mineralization overprints the synvolcanic rocks and pre-mineral QFP intrusions. Gold mineralized zones are often associated proximal to the contacts of the pre-mineral QFP intrusions. Gold mineralized zones consists of a vein-type quartz-pyrite \pm carbonate \pm tourmaline \pm gold veins, or a replacement-type that are pyrite-rich corridors that are zoned from an inner high-grade gold silica-pyrite assemblage to an outward lower-grade gold sericite-pyrite \pm carbonate assemblage.

The mineralization is currently known for a lateral extent of 3,000 metres and a vertical extent of approximately 1,600 metres. The deposit is subdivided into four areas: the Lynx area (Lynx Main, Lynx HW, Lynx SW, Triple Lynx and Lynx 4), the Main area (Zone 27, Caribou 1, Caribou 2, Caribou Extension, Bobcat, Mallard, Windfall North, F-Zones), the Underdog area; and the Triple 8 area (Figure 7-7). Current drilling is testing the extensions of many of these areas, mainly in the Lynx area. All zones generally trend east-northeast and plunge roughly 35° to 40° . A brief description of the mineral zones and their location in the deposit is presented below.

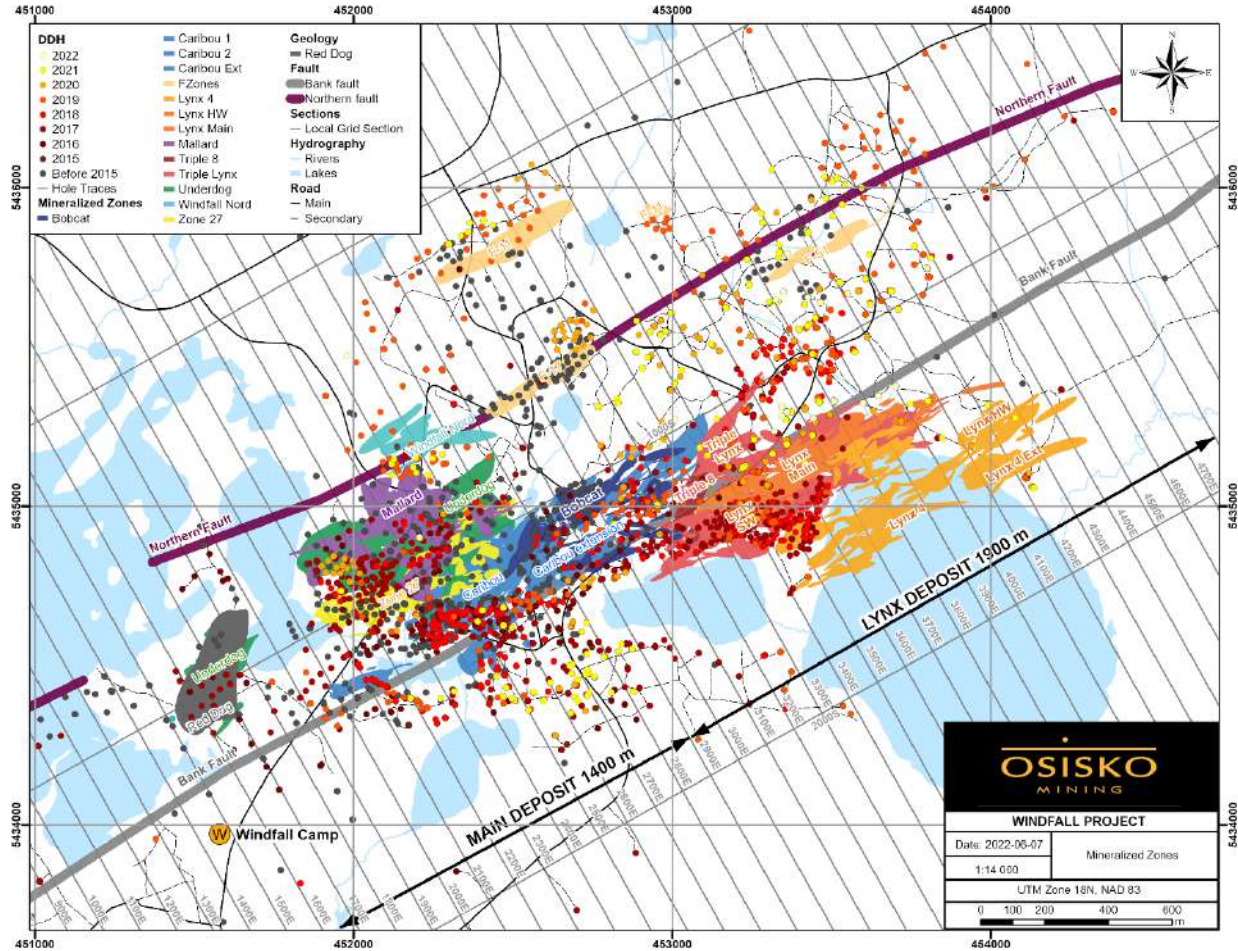

Figure 7-7: Surface projection of the mineralized zones of the Windfall deposit and the locations of drill holes (Osisko) grouped by year
 Dark grey polygon illustrates the surface projection of the post-mineral Red Dog QFP intrusion

The Lynx area consists of five gold mineralized zones located in the east-northeast portion of the deposit (Figure 7-7 and Figure 7-8). Most of the Lynx mineral zones form an extensive anastomosed network of quartz-pyrite veins (i.e., vein-type mineralization) and associated sericite-silica-pyrite replacement zones that occur in proximity to a swarm of large quartz eye QFP intrusions that intrude a thick sequence of felsic volcanics and gabbro intrusions. The Lynx area is located in the hinge and along the southern limb of an open fold plunging at 40° towards the east-northeast along the Bank fault-shear zone. The Lynx Main, Lynx HW, Lynx SW and Lynx 4 zones are closest to the Bank fault and are locally deformed by the latter. In contrast, the Triple Lynx zone is located roughly 200 m to 300 m lateral distance from this structure and occurs beneath a thick gabbro intrusion (e.g., Figure 7-9).



The Main area consists of six gold mineralized zones located in the central portion of the deposit (Figure 7-7 and Figure 7-8). Gold mineralization is located along the contacts of east-northeast trending narrow subvertical pre-mineral QFP dikes within a package of felsic to mafic volcanic rocks. Most mineral lenses in the Main area are associated with a replacement-type mineralization occurring near contacts between volcanic rocks and pre-mineral QFP dikes. For Zone 27, gold mineralization is hosted proximal to the contacts between basalt-andesites and the pre-mineral large quartz eye QFP dikes, whereas in the Caribou zone it is mostly hosted at the contacts between felsic volcanics and pre-mineral large quartz eye QFP dikes. The Main area terminates at the upper contact of the thick post-mineral Red Dog intrusion. The F-Zones and the Windfall North zone are located in the northern portion of the deposit (Figure 7-7). Gold mineralization in the F-17, F-11, F-51 and the Windfall North zones trend to the northeast, subparallel to the lens in the Main area, but dip steeply to the northwest. Windfall North, F-17 and F-51 are aligned along the same trend, whereas the F-11 zone is located 500 m to the northwest. The mineralization in these zones is similar to the replacement-type mineralization observed in other parts of the deposit and the zones are located proximal to the contacts between basalt and pre-mineral large quartz eye QFP dikes.

The Underdog area is located in the southwestern portion of the deposit (Figure 7-7 and Figure 7-8) and is separated from the Main area by the post-mineral Red Dog intrusion. The gold mineralization is hosted in a large stock composed of three phases of pre-mineral QFP intrusions and locally in the surrounding host mafic-intermediate volcanic rocks (Figure 7-10). The mineralization in the Underdog area is similar to that observed in the Lynx zone and is composed of an extensive anastomosed network of quartz-pyrite veins hosted in strongly sericitized and silicified pre-mineral QFP intrusions. Mineralization is commonly located along the contacts of the various pre-mineral QFP intrusive phases. The top of this deeper mineral zone starts at around 600 m depth and continues to depths of roughly 1,600 m where it is still open at depth and down-plunge. The Triple 8 area is located 660 m east from the closest mineralized intercept in the Underdog area (Figure 7-8).

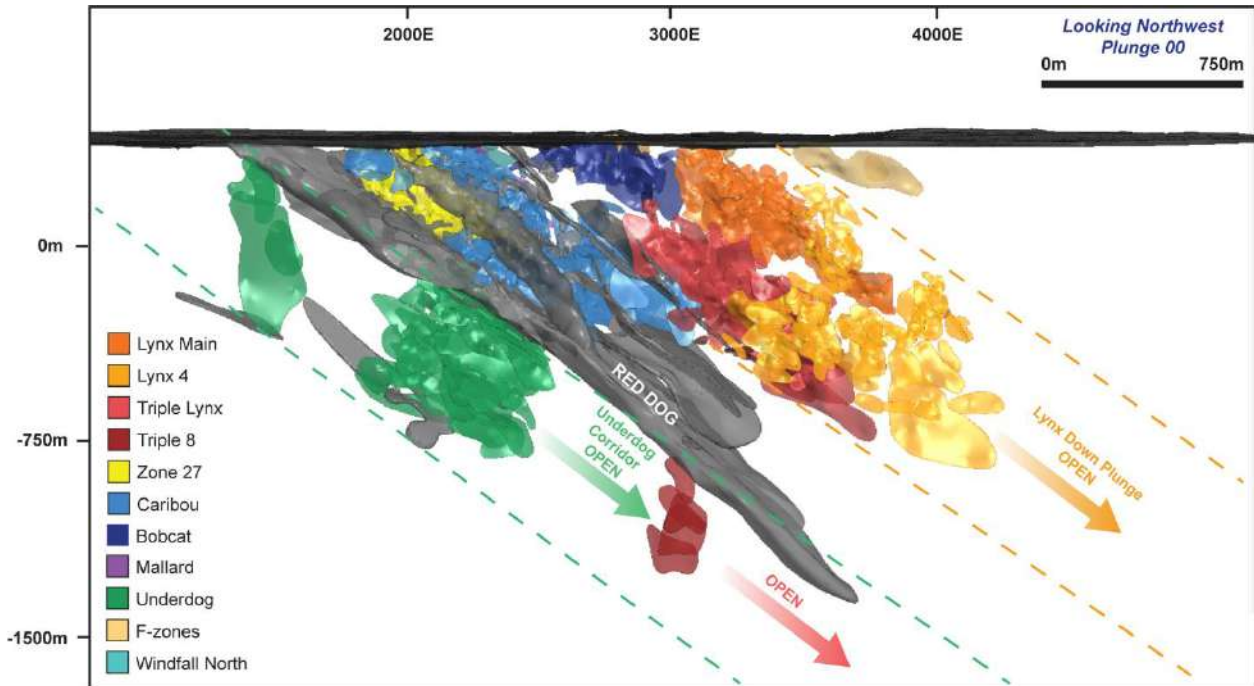

Figure 7-8: Leapfrog 3D modelling longitudinal section (looking northwest) illustrating the geometry of the mineralized zones plunging 35° to the northeast, exploration is open at depth for all zones

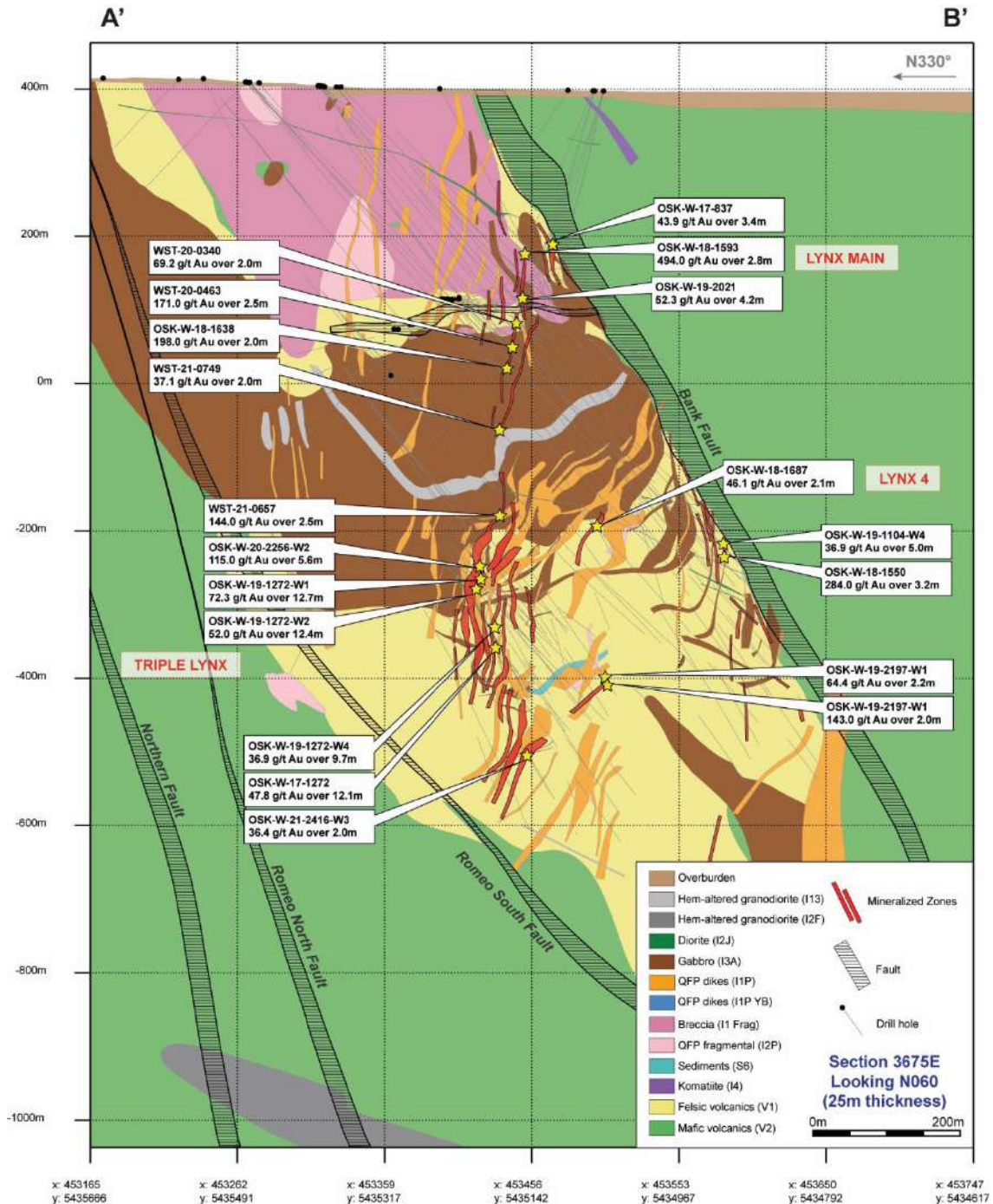
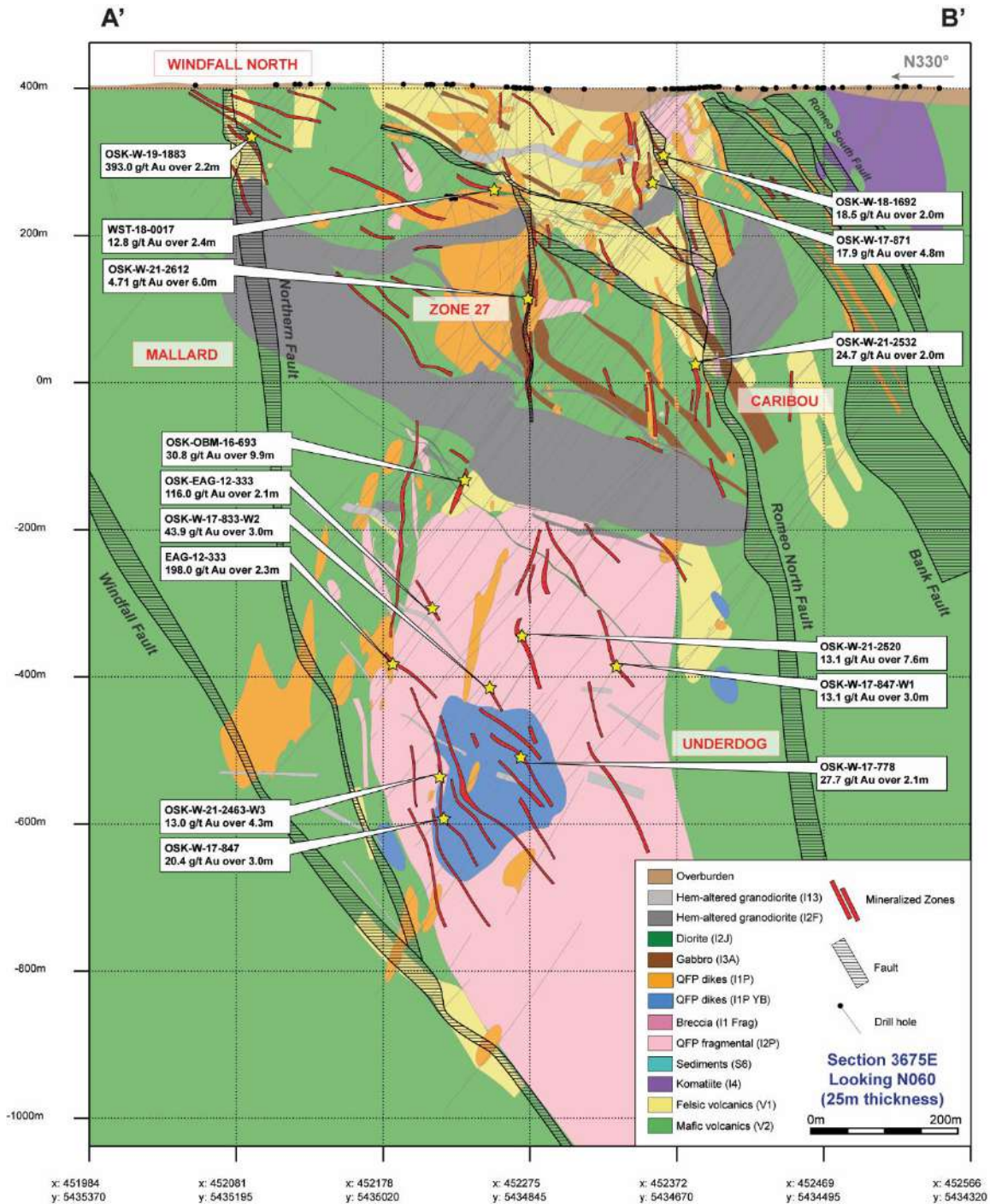

Figure 7-9: Simplified northwest-southeast vertical cross-section of the geology of the Lynx area of the Windfall deposit
Along grid line 3675E (A'-B' in Figure 7-4), showing the geological setting and geometry of mineralized zones shown in red (Lynx Main, Lynx 4 and Triple Lynx)





8. Deposit Types

8.1. Windfall Deposit

The Windfall deposit is classified as a pre-Temiskaming intrusion-associated gold deposit due to: 1) a temporal and spatial association of gold with felsic calc-alkaline QFP intrusions; and 2) the main gold event (i.e., vein- and replacement-type mineralization) being interpreted to pre-date known regional scale deformation. Gold mineralization is structurally controlled and is hosted in: 1) a series of extensional faults and fractures that are concentrated in areas of contrasting competencies, often located proximal to the contacts between pre-mineral QFPs and host volcanic rocks; 2) along boundaries between flat-lying lithologies and steeper structures; and 3) along boundaries of chemical contrast between ultramafic-mafic and felsic rock types. The mineralization style is variable (i.e., vein- to replacement-type) and is largely dependent on host rock composition. Mineralization consists of a network of quartz-pyrite veins and an associated silica-sericite-pyrite alteration assemblage. The mineralization and alteration have strike lengths of >2 km that show, as of yet, no recognized vertical zoning. The QFP intrusions were emplaced as a product of tectonism and act as competent host rocks that localize favourable structures for gold-bearing hydrothermal fluids.

This model significantly improved the targeting potential of new mineralized zones at the deposit scale and contributed to expanding known mineralized zones.

8.2. Intrusion-associated Gold Deposits

The following description of intrusion-associated gold deposits is taken from Dubé and Mercier-Langevin (2020). The term “intrusion-associated gold deposits” has been used to include a significant number of gold deposits that are closely spatially associated with intermediate to felsic intrusions that consist of zones of veinlets, stockwork breccias, dissemination, and/or replacement mineralization. The deposits occur across the Abitibi belt but are mostly located in or within a few kilometres (<5 km) from the E-W oriented major fault zones, or in some cases along ENE oriented fault zones.

In these deposits, intrusive rocks are host to at least part of the mineralization. The mineralized zones consist of disseminated sulphides; quartz ± pyrite veinlets and/or stockwork breccia and associated replacement zones of various geometries reflecting primary distribution and/or superimposed deformation. Based on the geologic setting, composition, and age of the host or associated intrusions, this style of mineralization can be divided into two main subtypes: 1) pre-Temiskaming intrusion-associated deposits; and 2) syn-Temiskaming intrusion associated deposits (Robert, 2001).



Pre-Temiskaming gold deposits are structurally controlled gold systems that are associated to subalkaline felsic intrusions that postdate construction of the volcanic assemblages but predate the fluvial-alluvial sedimentary sequences and associated alkaline/shoshonitic magmatism. The gold mineralization in these systems is commonly overprinted by metamorphism and superimposed fabrics, which indicate their early timing with respect to regional metamorphism and deformation.



9. Exploration

Table 9-1 below briefly summarizes the exploration work completed by Osisko on the Windfall and Urban-Barry properties from April 28, 2015 (the day following the effective date of the Preliminary Economic Assessment report from Tetra Tech in 2015 (McLaughlin et al., 2015)) to June 7, 2022. Drilling campaigns during that period are covered under Chapter 10.

Table 9-1: Summary of exploration work performed at the Windfall deposit and the Urban-Barry property

Year	Type	Survey	Area	Company	Amount	Reference
2015	Geochemistry	Till survey	Urban-Barry belt and Windfall deposit	Osisko Exploration James Bay (Osisko Gold Royalties Ltd.)	777 samples (fine fractions, gold grain counts and heavy mineral concentrate analysis)	Gaumond and Trépanier (2015)
2016	Geophysics	Airborne electromagnetic and magnetic survey	Urban-Barry belt	SkyTEM Canada Inc.	9,277 km (200 m spacing)	SkyTEM Canada Inc. (2016)
	Geophysics	Airborne magnetic survey	Urban-Barry belt	Geotech Ltd.	35,240 km (50-100 m spacing)	Geotech Ltd. (2016)
	Geochemistry	Till survey	Windfall deposit	Osisko Exploration James Bay (Osisko)	28 samples (fine-fractions) and 19 samples grain counts and heavy mineral concentrate	Gaumond et al. (2016)
	Exploration	Prospecting	Windfall area/ Urban-Barry belt	Osisko Mining Inc.	6 weeks	Sproule and Tuscherer (2016)
	Geophysics	Ground IP survey OreVision®	Project Urban-Barry Canton Buteaux	Abitibi Géophysique Inc.	35.9 km (200 m spacing)	Abitibi Géophysique Inc. (2017b)



Year	Type	Survey	Area	Company	Amount	Reference
2017	Geophysics	Airborne magnetic survey	Urban-Barry belt	Geo Data Solutions GDS Inc.	5,307 km (100 m spacing)	Geo Data Solutions GDS. Inc. (2017)
	Geophysics	Airborne electromagnetic survey (VTEM™)	Urban-Barry belt	Geotech Ltd.	1,496 km (200 m spacing)	Geotech Ltd. (2017)
	Geophysics	Ground IP survey	Fox deposit area	Abitibi Géophysique Inc.	53.9 km (100 m spacing)	Abitibi Géophysique Inc. (2017c)
	Geochemistry	Prospecting	Urban-Barry belt	Osisko Mining Inc.	447 samples	Girard and Roussel-L'Allier (2018)
	Geochemistry	Till survey	Urban-Barry belt	Osisko Mining Inc.	288 samples (fine fractions, gold grain count, and heavy mineral concentrate analysis. 16 till samples only for fine fraction analysis.	Girard and Roussel-L'Allier (2018)
	Geophysics	IP survey	Black Dog deposit	Abitibi Geophysics Inc.	57.6 km	Abitibi Géophysique Inc. (2017a)
2018	Geophysics	IP survey	Windfall deposit area	ClearView Geophysics Inc.	121 km ² (50 and 100 m spacing)	ClearView Geophysics Inc. (2017)
	Geochemistry	Till survey	Urban-Barry belt	Osisko Mining Inc.	274 samples	Girard and Aumond (2018)
	Geochemistry	Prospecting	Urban-Barry belt	Osisko Mining Inc.	302 Multi-element analyses and 82 whole-rock analyses	Girard and Aumond (2018)
	Geology	Trenching/ Channel sampling	Urban-Barry belt (Chanceux area)	Osisko Mining Inc.	17 trenches; 368 m of channel sampling	Girard and Aumond (2018)
	Geophysics	IP survey	Urban-Barry Belt (Lacroix Township)	Abitibi Geophysics Inc.	32.125 km (200 m spacing)	Abitibi Geophysics Inc. (2018a)
Geophysics	Hole-to-Hole 3D IP	Windfall deposit area – Triple 8 zone	Abitibi Geophysics Inc.	3 DDH	Abitibi Géophysique Inc. (2018b)	



Year	Type	Survey	Area	Company	Amount	Reference
2019	Geophysics	(Cont.) Hole-to-Hole 3D IP	Windfall deposit area – Triple 8 zone	Abitibi Geophysics Inc.	3 DDH	Abitibi Géophysique Inc. (2018b)
	Geophysics	Optical Televiwer	Windfall deposit area	DGI Geoscience Inc.	3 DDH	N/A
	Geophysics	Vp and SG on core samples (stage 1)	Windfall deposit area	HiSeis Ltd.	838 samples in 5 DDH	Villahermosa (2019)
	Underground	Bulk Samples	Zone 27/Lynx	Osisko Mining Inc.	5,500 † (Zone 27) 5,716 † (Lynx 311); additional 4,180 m of ramp development from historical 1,420 m of development from the Noront Ramp)	Roy et al. (2020 a, b)
2020	Geophysics	Cross-hole IP	Discovery 1 DDH	Abitibi Geophysics Inc.	26 DDH pairs	Abitibi Géophysique (2020)
	Geochemistry	Soil survey	Urban-Barry belt	Osisko Mining Inc.	200 B-horizon and 230 peat samples	Bouchard and Girard (2021)
	Geochemistry	Prospecting	Urban-Barry belt	Osisko Mining Inc.	11 multi-element analyses and 19 whole-rock analyses	N/A
2021	Geochemistry	Prospecting	Urban-Barry belt	Osisko Mining Inc.	79 multi-element analyses and 30 whole-rock analyses	Côté-Lavoie and Girard (2021)
	Geochemistry	Soil survey	Urban-Barry belt	Osisko Mining Inc.	547 samples	Côté-Lavoie and Girard (2021)



10. Drilling

The information reported in this chapter was obtained from Osisko's exploration team during the site visit and through data exchanges. Osisko produced employee's reference documents for logging and sampling procedures.

10.1 Windfall Project

This section summarizes Osisko's drilling program from October 19, 2015 to June 7, 2022 on the Windfall deposit. Osisko's drilling constitutes a significant majority of the drilling completed at the project. Earlier drilling by previous operators can be found in Chapter 6 of this report. The main objective of the 2021 drilling program on the property was to conduct conversion drilling from the inferred to the indicated category.

Drilling was carried out by Rouillier Drilling, Orbit Garant-Myuka Drilling, Major Drilling and G4 Drilling. The number of rigs employed has varied from 1 to 34. Most diamond drilling recovered NQ-sized (47.6 mm) core with down hole orientation surveys performed by the drilling companies using Reflex tools (EZ-SHOT™, EZ-GYRO™, GYRO SPRINT-IQ™) or Axis tools (CHAMP GYRO™) that simultaneously measures azimuth, inclination and total magnetic field and magnetic dip (only with Reflex EZ-SHOT™). Oban/Osisko used the "CorientR" tool or "Reflex Act III RD" system to orient the core and measure structural features.

10.1.1 Overview

Since 2015, a total of 1,386,473 m of surface exploration drilling and 291,060 m for underground drilling has been completed by Osisko (formerly Oban Mining Corp.). Figure 10-1 also illustrates historical drill holes in black (drilled before 2015).

Details of the various drilling programs are summarized in Table 10-1. Drilling also included 4,536.5 m for metallurgical studies. The distribution and orientation of drill holes in representative cross-sections in the Lynx and the Main areas are illustrated in Figure 10-2 and Figure 10-3, respectively.

Drilling performed by Osisko since 2015 significantly expanded known mineralized zones in the Underdog and Main areas, in zones such as Caribou 1, Caribou 2, Caribou Extension, Bobcat, Zone 27, Mallard, Windfall North and specific zones in the F-Zones (e.g., F-51). Moreover, significant new mineralized zones were discovered from the continuous drilling on the deposit. These include the Lynx Main, Triple Lynx, Lynx 4, Lynx HW, Lynx SW and Triple 8. These newly discovered zones contributed to the increase of the gold content of the Windfall deposit over the years. Drilling undertaken since 2015 delineates the footprint of the deposit's mineralization to a vertical depth of 1,600 m, to over 1,700 m laterally, and up to 3,000 m in strike length.

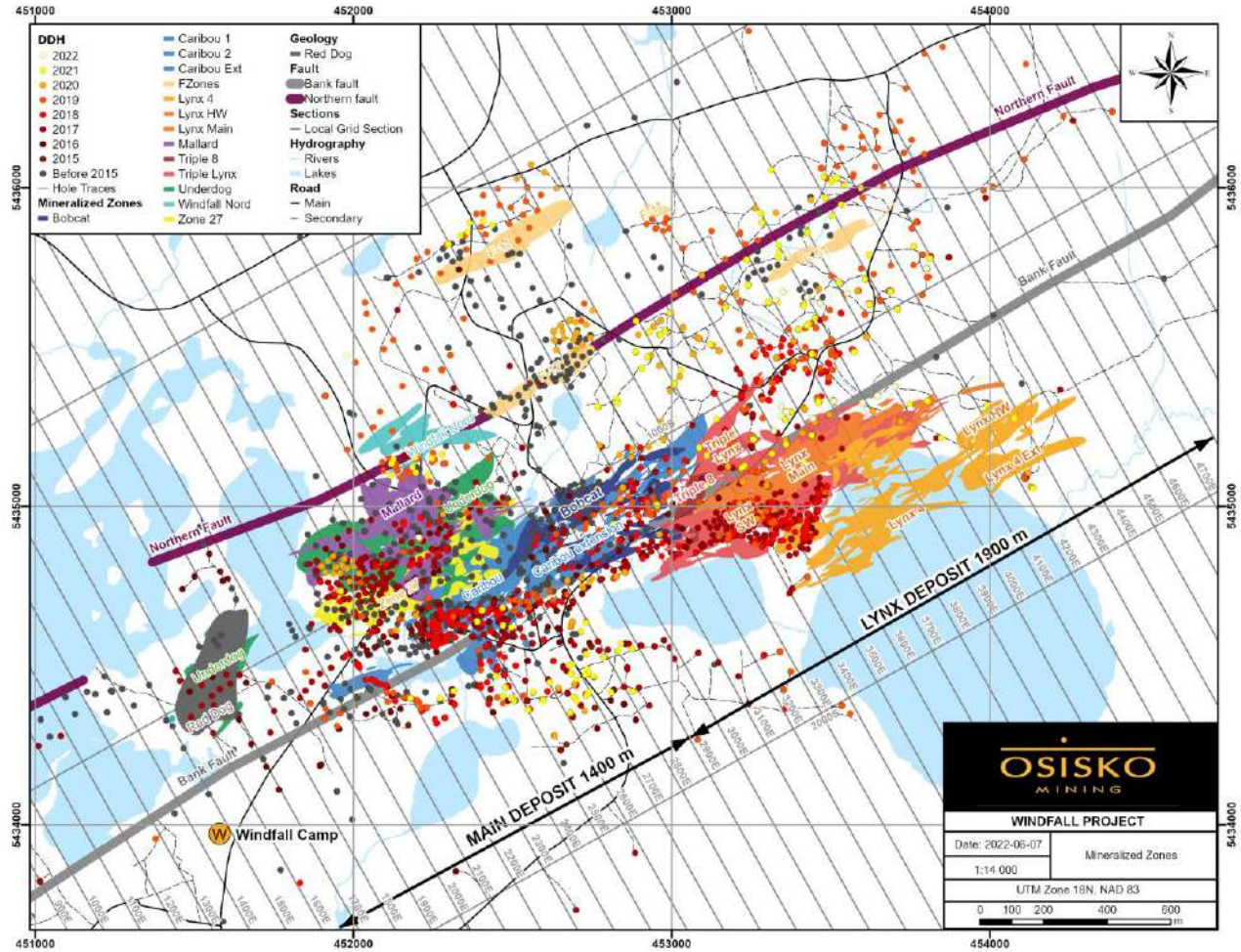

Figure 10-1: Windfall property map showing drill holes completed from 2015 to June 7, 2022 by Oban Mining Corporation and Osisko Mining. Historical drill holes are also illustrated and are represented by black circles.



Table 10-1: Drill hole summary and number of assay samples delivered from 2015 to June 7, 2022 (Osisko)

Year	Type	Count	Length (m)	Assay Sample Count ⁽²⁾
2015	DDH	17	9,473	
	Wedge	0	0	
	Extension	0 ⁽¹⁾	189	
	Total	17	9,662	4,785
2016	DDH	203	91,495	
	Wedge	19	12,820	
	Extension	5 ⁽¹⁾	1,745	
	Total	227	106,060	84,086
2017	DDH	674	323,941	
	Wedge	93	49,859	
	Extension	31 ⁽¹⁾	11,126	
	Total	798	384,925	263,614
2018	DDH	404	138,869	
	WST ⁽³⁾	43	5,181	
	Wedge	66	27,991	
	Extension	8 ⁽¹⁾	7,714	
	Total	521	179,755	199,198
2019	DDH	417	163,342	
	WST ⁽³⁾	254	31,897	
	Wedge	176	86,093	
	Extension	0 ⁽¹⁾	16,663	
	Total	847	297,995	176,856
2020	DDH	206	96,356	
	WST ⁽³⁾	383	86,024	
	Wedge	182	95,028	
	Extension	0 ⁽¹⁾	4,215	
	Total	771	281,624	230,310
2021	DDH	207	112,729	
	WST ⁽³⁾	463	135,213	
	Wedge	235	116,480	
	Extension	0 ⁽¹⁾	3,183	
	Total	905	367,605	328,048
2022	DDH	5	2,752	
	WST ⁽³⁾	101	32,745	
	Wedge	31	13,580	
	Extension	0 ⁽¹⁾	828	
	Total	137	49,905	64,483
Recent drill hole (2015 to 2022)		4,223	1,677,534	1,351,373
Historical DDH (< 2015)		757	201,170	
Total		4,980	1,878,704	

⁽¹⁾ Count of only newly created entries in the Windfall central database.

⁽²⁾ Count by analysis date.

⁽³⁾ Underground drilling.

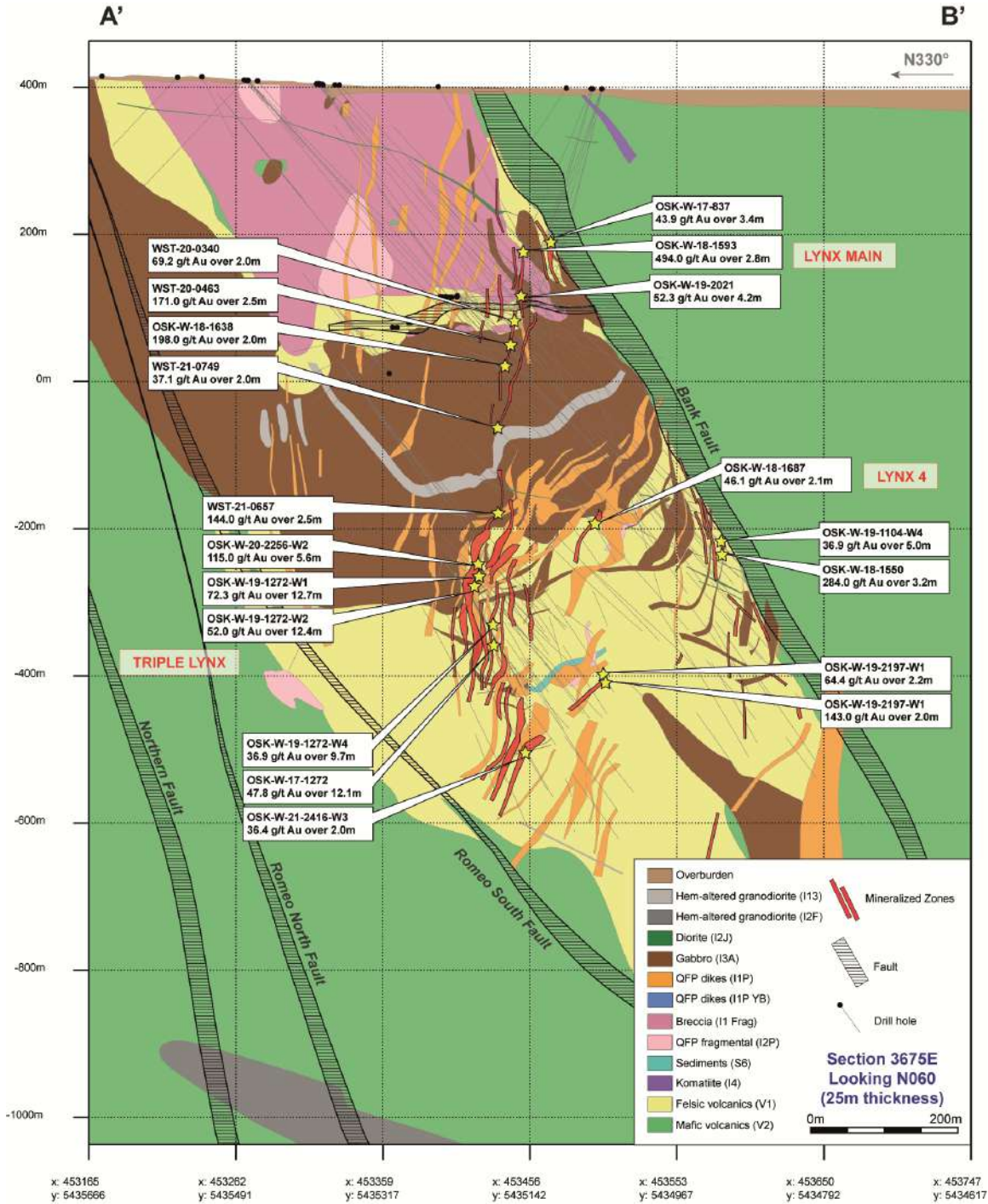

Figure 10-2: Representative geological cross-section showing the distribution of drill hole spacing and orientation in the Lynx area. Significant assay results are also shown (Section 3675E). All lengths are core lengths ("CL") unless specified otherwise.

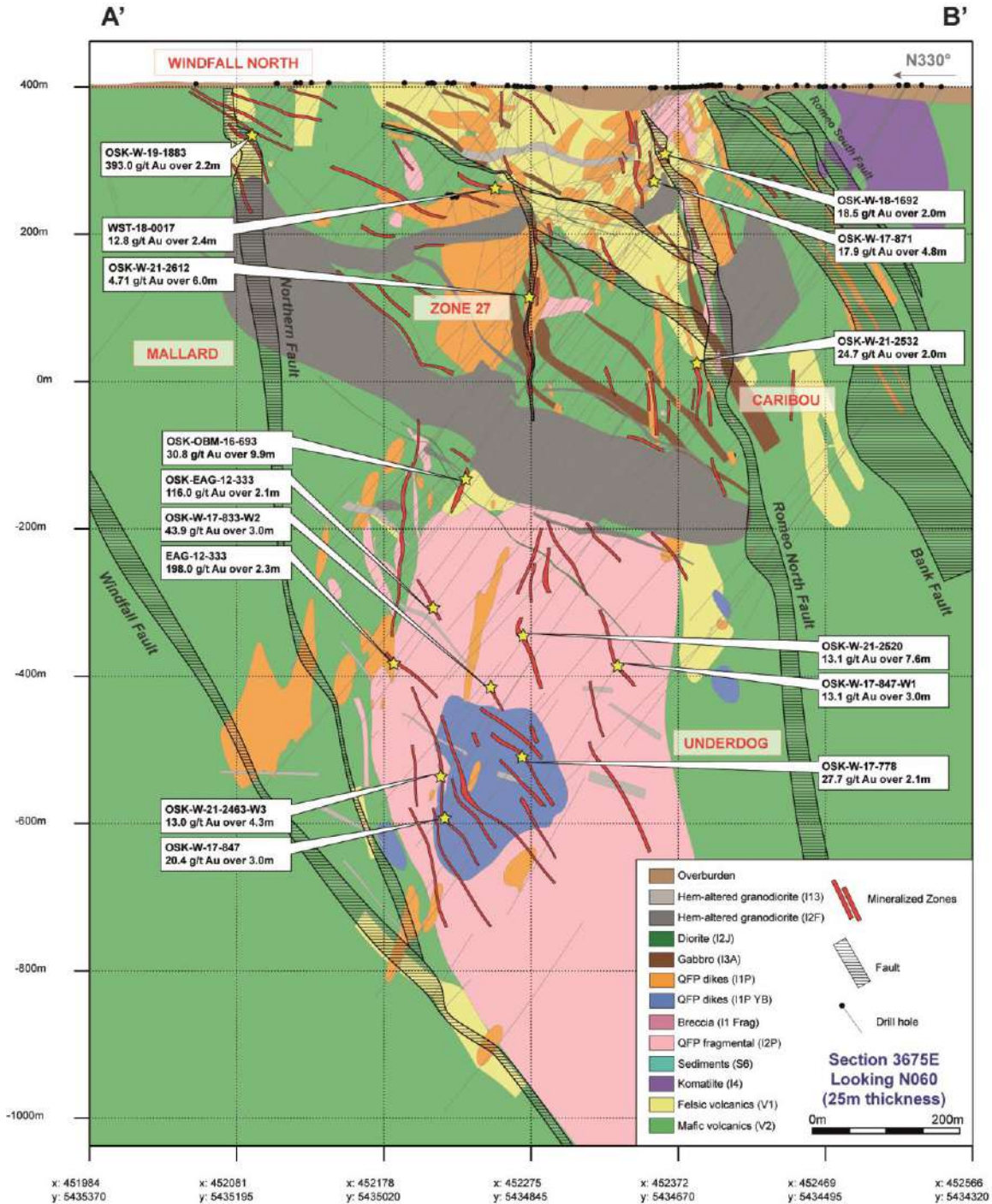

Figure 10-3: Representative geological cross-section showing the distribution of drill hole spacing and orientation in the Main area. Significant assay results are also shown (Section 2500E). All lengths are core lengths unless specified otherwise.



10.1.2 Drilling Methods

Most drilling completed at Windfall consists of wireline diamond drilling recovering NQ size (47.6 mm) drill core. Metallurgical drilling used HQ (63.5 mm) and PQ (85 mm) sized core, although wedges have been made from existing metallurgical holes with NQ-sized core. Directional core drilling (Devico®) used 31.5 mm sized core.

Directional core drilling has been used on the Windfall Project since June 2016 using Devico®'s tool DeviDrill™. The DeviDrill™ allows controlled deviation of the drill hole path by making multiple branches from a mother-hole, reaching targets within a one percent error. Field technicians from a qualified license user, Tech Directional Services Inc., are on-site on a full-time basis to control the directional core drilling.

Drill hole deviation surveying at the Windfall Project from 2015 to 2017, included singleshots and multishots using the electronic down hole instrument Reflex EZ-SHOT™. Singleshot measurements are taken every 30 m during drilling. Multishots are taken once the drill hole is completed and measurements are taken every 3 m up hole. From March to December 2017, the North Seeking Champ Gyro™ system provided by TMC Géophysique was used for deviation surveying when the host rock was magnetic. Since January 2018, the Reflex EZ-GYRO™, Reflex GYRO SPRINT-IQ™ and Axis CHAMP GYRO™ were used on all drill rigs. Measurements are taken every 3 m (Reflex GYRO SPRINT-IQ™ and Axis CHAMP GYRO™) to 9 m (Reflex EZ-GYRO™) down hole.

The Reflex TN14 Gyrocompass™ has been used to align the drill rigs to the correct azimuth and dip since May 2016. Prior to this date, the Azimuth Pointing System ("APS") was used to align the drill rigs. Drill hole coordinates are entered directly into the wireless handheld unit on site, showing the drill rig's live orientation.

Most drill hole casings remain anchored in bedrock to allow for future surveying, drill hole lengthening, or cementation. A red metallic cap flag with the drill hole name is placed on the remaining casing by technicians once the drill hole is completed.

All drill core is stored in the yard of the core shack area at the Windfall camp. Each core box is identified with an aluminum tag indicating the drill hole name, box number and from-and to-metres of the core interval located inside the box.



10.1.3 Field Procedures

The drill core is placed into wooden core boxes at the drill site. Blocks are used to separate the core in the box at the beginning and end of each drill run. The core boxes are labelled and closed with transparent tape by the drillers. The drill core is brought back to the core shacks at the end of every shift from each drill site by drill contractor personnel and the core boxes are placed on individually labeled trestles in front of every core shack. Geo-technicians are responsible for placing the core boxes in order and transporting them into the core shacks and onto the core logging tables.

When working with the "CorientR" tool or the "Reflex Act III RD" system, which provide an oriented drill core reference, the drill core received from the drill is aligned according to the driller's marks drawn at the end of each 3 m interval drilled. The mark indicates the lower portion of the drill hole. A blue line joining the marks is then traced by a core handling technician, indicating the bottom of the core. The core is then put back into the box, oriented with the blue line in the upright (top) position.

10.1.4 Geological Logging

Once geotechnical measurements are completed and the core is oriented, the drill core is logged by a geologist or an engineer recording a detailed description of the lithologies, structures, mineralization, alteration and veining directly into the Datamine core logging software (DH Logger). Qualified professionals employed by Osisko are members in good standing of the *Ordre des Géologues du Québec* ("OGQ") or the *Ordre des Ingénieurs du Québec* ("OIQ").

Structures are recorded using the Reflex IQ-Logger™ electronic instrument. Rock units are also occasionally identified using a handheld X-Ray fluorescent ("XRF") device. Handheld Vanta X-ray fluorescence energy dispersive spectrometer, generally known as an XRF analyzer, is routinely used at Windfall to discriminate between different lithologies, including porphyry dikes, felsic volcanics and intermediate-mafic rocks. A semi-quantitative analysis of a rock sample of 15 to 20 seconds is generally sufficient to determine the geochemical signature of a rock and its respective rock unit. However, for an even more reliable result, a 40-second analysis is recommended. The values (e.g., TiO₂, Zr, Y and Nb) can be written on the core and are documented within the drill log.

After completing the core description, the geologist or engineer is responsible for marking the samples for assay on the core using a red water-proof marker. Photos of the core for the entire drill hole length are then taken with the sample tags (four boxes photographed per picture).

Once the core samples are cut, the boxes containing the remaining core halves are placed in an outdoor permanent core rack.



10.1.5 Core Recovery

Core recovery and rock quality designation (“RQD”) are measured and calculated for each core box and recorded in the drill log. Rock units intersected by drilling are generally solid, yielding an effective core recovery of 99.88%

10.1.6 Collar Surveys

From 2015 to spring 2018, surface drill hole collars were spotted in the field using an APS instrument. Since the spring of 2018, surface drill hole collars are spotted using a high-precision Leica GPS (precision of ± 0.05 m). Down hole surveying has been performed routinely on every drill hole. The coordinate system used is UTM NAD 83 Zone 18.

Before September 2018, the collars were surveyed by Corriveau J. L. & Assoc. Inc. (from Val-d’Or) using a high-precision Leica GPS (precision of ± 0.05 m). The drill hole collars are currently surveyed in-house by Osisko’s geotechnicians using a high-precision GPS system (Leica GS10 3.0 receiver with a Viva GS16 antenna). The final surveyed coordinates are imported into the database.

Underground drill hole collars are surveyed using a Leica TS16 total station. The coordinates are measured from a network of reference points that cover all of the underground development. The reference network begins at the portal entrance with three permanent stations installed by Corriveau J. L. & Assoc. Inc. (JLC-2017-1, JLC-2017-2 and JLC-2017-3) using the UTM NAD 83, Zone 18 system. The accuracy of measurements decreases by ± 0.001 m every 100 m underground.

10.1.7 Drill Hole Validation

DH Logger, from the Fusion suite of software supplied by DATAMINE, is used to plan, log, view and manage down hole-related data. In association with DH Logger, Fusion is a central database and a management system for geological, geochemical, geotechnical, geophysical, assay, QA/QC and any field data.

The logging method at the Windfall Project utilizes a compilation of best logging practices employed in exploration. According to mining industry best practices, the method preserves the integrity of raw results and meets all the current requirements for data capture and management.



10.1.8 Drill Spacing

10.1.8.1 Surface Drilling

Drilling has been conducted over the Windfall deposit on an area 3,500 m in length by 1,800 m in width. The drilling pattern was designed as much as possible to sample the deposit orthogonal to the interpreted strike and dip of the gold mineralization. The majority of the drill holes were drilled with a dip varying between -45° to -70° .

From surface to a vertical depth of 800 m, the spacing mostly used for surface drilling is 25 m by 25 m, although 12.5 m by 12.5 m is also used locally in the Lynx Main and Zone 27 areas. Below a vertical depth of 800 m down to approximately 1,600 m, drill hole spacing in the down-plunge extensions of zones is mostly 50 m by 50 m.

Collars for surface drill holes are located mostly south of the zones in Main zone and Underdog. They are mostly located north of the zones in the Lynx area due to terrain constraints (lakes, swamps, etc.).

10.1.8.2 Underground Drilling

Underground drilling has been conducted in the Zone 27, Caribou and Lynx zones with 1 to 10 rigs since the fall of 2018. The majority of the drill holes were drilled with a dip varying between -50° and $+50^{\circ}$ and lengths varying between 15 m and 921.5 m. The spacing used for underground core holes is 25 m by 25 m and 12.5 m by 12.5 m. Drill stations spaced approximately every 100 m to 150 m were used for collars.

Underground drilling was used to reduce the length of definition drilling operations, optimize intersection angles, and target sectors unattainable from the surface due to terrain constraints (lakes, swamps, etc.).

10.2 Exploration Drilling, Urban-Barry Property

Drilling performed by Osisko since 2016, over regional targets, led to the discovery of new mineralized zones in the Urban-Barry area, including the Black Dog (discovery hole OSK-BD-16-002 intersected 3.42 g/t Au over 32.1 m CL, including 6.14 g/t Au over 14.4 m CL), the Fox (discovery hole OSX-W-16-717 intersected 3.22 g/t Au over 11.6 m CL), the Fox West (discovery hole OSK-UB-19-132 returned 16.7 g/t Au over 2.8 m CL), and more recently, the Golden Bear (discovery hole OSK-UB-21-232 returned 27.4 g/t over 6.7 m) showings. These represent the most significant discoveries outside of the Windfall deposit realized by Osisko since 2016.



The Black Dog showing occurs in the southern block of the Urban-Barry property and is defined for approximately 1,200 m along a northeast-trending linear magnetic feature. The mineralization in the Fox zone is followed over approximately 200 m in an east-northeast orientated corridor. Gold mineralization is spatially associated with the contacts of porphyry dikes with volcanic rocks. The mineralization occurs in both the hanging wall and the footwall of the dikes. The Fox West showing is hosted in an east-north-east corridor and consists of altered porphyry dikes hosted in mafic volcanics. The mineralization style in this zone occurs along intrusive porphyry contacts with volcanic rocks, similar to the mineralization style in the initial 2016 Fox discovery. Gold mineralization in the Golden Bear showing occurs as grey quartz and pervasive silica veinlets that contain pyrrhotite, pyrite, sphalerite and visible gold that are hosted dominantly in an epidote-carbonate-sericite altered intermediate volcanic package (Grenier, 2021; Simard, 2022). The volcanic package is metamorphosed to the upper greenschist metamorphic facies. Regional exploration was successful in demonstrating that gold mineralization occurs outside of the footprint of the Windfall deposit. In the Fox, Fox West and Golden Bear showings, the gold mineralizing event is possibly related to the same gold event that formed the Windfall deposit.

The 2016 to 2017 Urban-Barry property drilling program was conducted from November 2016 to June 2017 over different sectors of interest in the area. In 2016, drilling was carried out by Rouillier Drilling and in 2017, drilling was carried out by both Rouillier Drilling and Orbit Garant.

A total of 93 drill holes were drilled for a total of 37,833.5 m. The first part of the program started in the eastern and southern part of the Urban-Barry property on the E1, E2, E7 and Black Dog areas, which were highlighted during the 2016 prospecting campaign. The second part of the program focused on properties in the vicinity, but outside, of the Windfall deposit footprint and included Fox, Bobtar and NE Windfall areas. The location of drill holes for the entire Urban-Barry drilling program is illustrated in Figure 10-4.

The 2018 Urban-Barry drilling program was conducted from January to May. A total of 24 drill holes, representing 7,302.4 m of drill core, were completed in three sectors, Great Bear (formerly known as Mongodon), Black Dog and Hébert Centre areas (Figure 10-4). In 2018, an agreement was signed between Osisko and Osisko Metals Inc. to create a joint venture for base metal and volcanogenic massive sulphide exploration in the Urban-Barry property (Urban-Barry Base Metals). Work conducted between May 2018 and June 2018 by Osisko included eight exploration drill holes, generally in the eastern portion of the claim boundaries (Figure 10-4). A total of 1,742.8 m was drilled.



The 2019 Urban-Barry drilling program was conducted from January to August over various sectors of interest in the Urban-Barry area. Drilling was carried out by Orbit Garant. A total of 69 drill holes were drilled for a total of 16,234 m. Six main areas were visited in the first part of the program, namely Thubière, Chanceux, Rouleau Nord, Souart, Fox and Macho (Figure 10-4). The second part of the program focused on the newly named Fox West area located in the Macho block.

The 2020 Urban-Barry drilling program was conducted in two parts, from January to March and from October to December. Orbit Garant carried out drilling for the first part and G4 Drilling for the second. A total of 28 drill holes were drilled for a total of 12,737.5 metres. Four main areas were visited during the first part of the program, namely Fox West, Rouleau, Bank Extension and Urban South Fault (Figure 10-4). The Bank Extension and Windfall SW areas were visited during the second part.

The 2021 Urban-Barry and Windfall Exploration drilling program was conducted from January to December. Drilling was carried out year-round by G4 Drilling, and by Rouillier Drilling from February to April. In all, a total of 113 drill holes were drilled for a total of 65,237 metres. Seven main areas were visited from January to June, namely Bank Extension, Windfall SW, Fold, Fox, Golden Bear (formerly known as Cross Fault), Windfall West and WUDZ. The second part of the program from July onward focused on the newly discovered Golden Bear showing.

The 2022 Windfall Exploration drilling program began in May and was still in progress at the effective date of the MRE presented in this technical report. Drilling was carried out by G4 Drilling. A total of 16 drill holes were drilled. A total of 6,950 m out of the 20,000 m program were drilled. The Golden Bear and Windfall West areas were visited.

No drilling from the Urban-Barry property was used in the resource estimate presented in this report. There are no current mineral resources on this property.

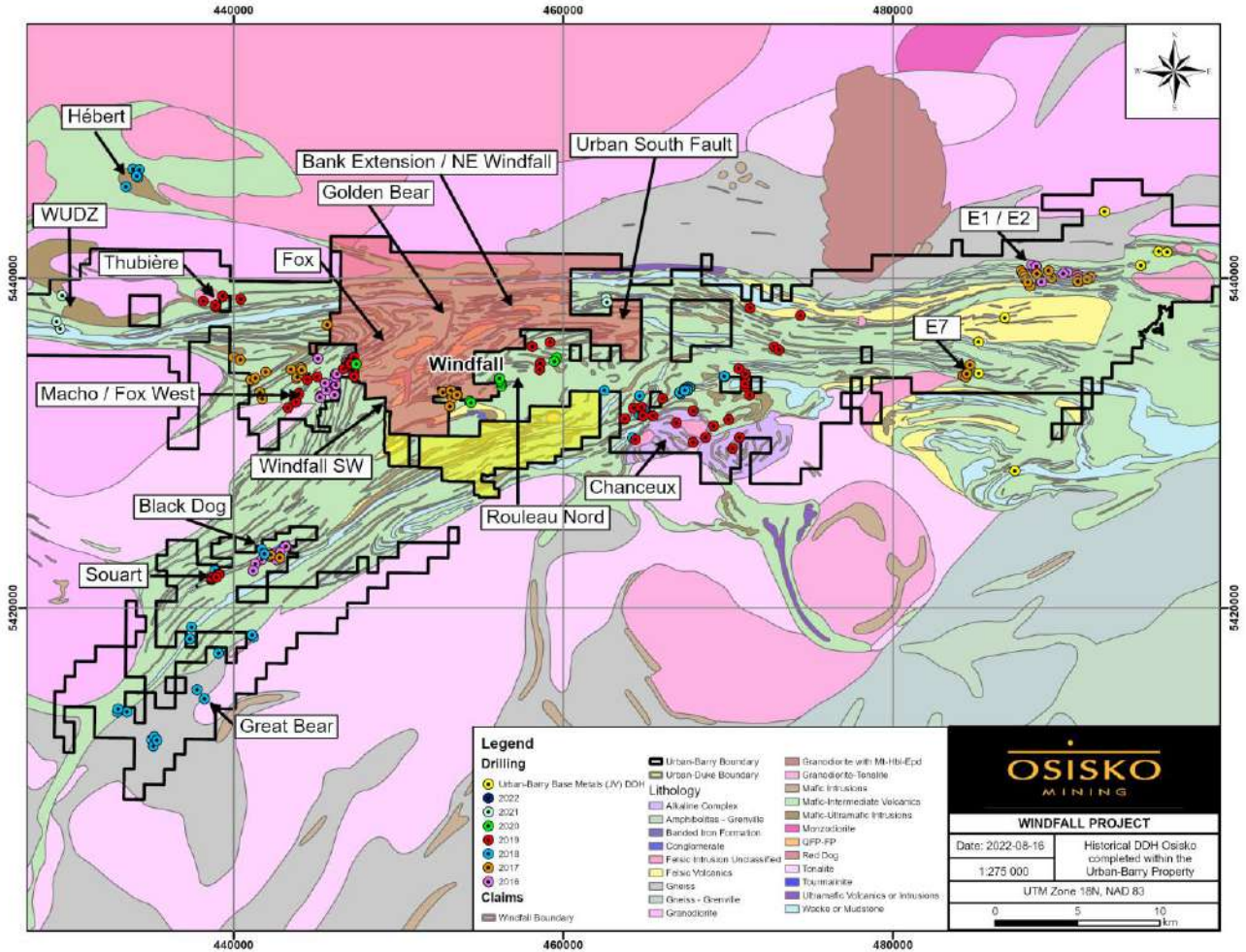

Figure 10-4: Exploration drilling (2016-2022) and the location of the informal sectors in Urban-Barry

10.3 Conclusions

The QP has examined the drilling and logging procedures used and described above. In the opinion of the QP, Osisko personnel have used industry standard best practices in the collection, handling and management of drill core and assay samples.

The QP is not aware of any drilling, sampling, or recovery factors that could materially impact the accuracy and reliability of the results presented in this report.



11. Sample Preparation, Analyses and Security

11.1 Windfall and Urban-Barry Properties

The following sections describe Osisko's sample preparation, analysis and security procedures for the diamond drilling programs at the Windfall Project. The QP did not conduct any independent drilling or sampling on the Windfall property. Osisko supplied data related to sampling, analytical, security and quality assurance-quality control ("QA/QC") protocols.

The information included in this chapter relates to samples taken from drilling campaigns for which the assay certificates were received after the 2015 Preliminary Economic Assessment effective date of April 28, 2015, and before the Osisko database close-out date of June 7, 2022.

11.1.1 Laboratories Accreditation and Certification

Osisko used ALS Minerals ("ALS") in Val-d'Or and in Lebel-sur-Quévillon, Québec, Canada as their primary sample preparation laboratories. ALS in Lebel-sur-Quévillon is only used for sample preparation. Depending on the capacity, at the discretion of ALS Val-d'Or, samples would be sent to various laboratories in Canada, Mexico and USA for sample preparation. ALS in Val-d'Or is the primary analytical (assay) laboratory. Depending on the capacity, at the discretion of ALS Val-d'Or, samples would be sent to ALS Vancouver, ALS Vientiane, ALS Lima and ALS Reno for analysis. ALS is independent of Osisko. ALS laboratories in Canada are currently accredited by the Standards Council of Canada (accredited laboratory number 689) to ISO 17025 for the analysis of gold by lead collection fire assay with atomic absorption spectrometry finish and the determination of gold by lead collection fire assay with gravimetric finish. The management system of the ALS Minerals Group laboratories is accredited to the International Organization for Standardization ("ISO") 9001:2008 by QMI Management Systems.

As a secondary laboratory, Osisko sends shipments to the Bureau Veritas Commodities Canada Ltd. ("BV") in BV Timmins, Ontario, Canada, for sample preparation. Samples are analyzed in BV Vancouver. BV is independent of Osisko. The laboratory is registered under the corporate ISO 9001 registration. The Timmins laboratory is in the process of seeking ISO 17025 accreditation for fire assay procedures. Still, it is listed on the Vancouver laboratory's ISO 17025 scope of accreditation (accredited laboratory number 720) as a qualified sample preparation facility. Off-site sample preparation and analytical procedures at Timmins follow those of Vancouver and are monitored regularly for QA/QC practices. The management systems of all BV sites are registered with the ISO 9001 Model for Quality Assurance and compliant with ISO/IEC 17025 General Requirements for the Competence of Testing and Calibration Laboratories.



11.1.2 Historical Sampling

Approximately 89% of the total drilled length on the project was drilled by Osisko and 91% of the assays used in the mineral resource estimate were from core drilled by Osisko.

The drill hole sampling preparation, analyses and security procedures utilized by Kerr Addison, DeMontigny, Alto and Inmet between 1986 and 1999 are unknown. Although it is reasonable to assume that these companies conducted their exploration activities in accordance with prevailing industry standards at the time, the QP conducted statistical analysis on both population and concluded that the historical drill holes could be used in the mineral resource estimate.

The drill hole sampling preparation, analyses and security procedures from 2003 to 2014 are presented in the Tetra Tech mineral resource estimate 2015 (McLaughlin et al., 2015).

11.1.3 Osisko Core Handling, Sampling and Security

Routine sampling of the diamond drill core for gold analysis was accomplished by adhering to previously established sampling guidelines. This procedure ensures the quality and accurate representation of the material sampled. The remaining split core is archived for future reference.

Preparation of designated drill core intervals to be sampled was completed using the following method:

- Drill core received from the drill at the core logging facility (core shack) was pieced back into continuous intervals to minimize any spaces between individual pieces of core and check for incorrect placement of the core by the drillers.
- When working with the CorientR tool or the Reflex Act III RD system, which provided an oriented drill core reference, the drill core received from the drill at the logging facility was aligned according to the driller's marks drawn at the end of each 3 m interval drilled, to indicate lower portion of the borehole. A blue line joining the marks was then traced by a core handling technician, indicating the bottom of the core. The oriented core was put back into the box with the blue line in the upright (top) position.
- After alignment, rotation and records made of the geotechnical measurements (recovery and RQD), the core was marked (with a china pencil) with 1 m hole-depth intervals. This annotation allowed for better depth precision between the drill-run meterage block markers inserted every 3 m run by the drillers.
- Intervals of core selected for sampling were marked with a red china pencil perpendicular to the core axis showing arrows to indicate the "from" and "to" range of each sample. The mark-ups were designed to assist the core cutters in sawing each core sample between the "from-to" arrows and solid red lines marking the end/beginning of each sample.



- Individual core samples are typically taken at 1 m intervals with minimum and maximum sample intervals from 0.3 m to 1.5 m. Collecting samples less than 1 m in length is discouraged unless done to respect lithological and/or mineralization contacts. Samples do not cross a lithological contact (except for minor veins and dikes less than 0.3 m). To minimize sample errors and simplify the entire sampling process, intervals are generally started and ended on a whole metre. Where sampled intervals fall between metre marks, subsequent samples are lengthened or shortened to bring the sequence in line with whole-number metre depths. Exceptions to the 1 m material occur to better represent the geology and or gold grade of the sample interval.
- Books containing numerical sequences of 50 pre-labeled, triplicate, water-durable sample tags are used; one to tag the core sample, a second to indicate the position of the sample in the core box, and the third remained with the book as an archival record of the samples' particulars such as sample ID, drill hole ID, sample interval from-to hole-depths, rock type and a brief sample description. From each sample sheet consisting of three identical perforated tags, the last two from the right (the third remaining in the sample book) were separated (torn) from the page and tucked along the side/under the core at the beginning of each sample in such a way that the core cutter could read the tag numbers.
- Digital photographs of the marked and tagged core boxes are taken for archival purposes.
- Blanks and standards are inserted as the sampling progresses to avoid mix-ups.
- Drill core, marked and tagged for sampling, is moved to the sawing room to be cut using electric motorized, diamond-impregnated bladed rock saws. The core saw operator(s) cuts and samples the core, one sample at a time, starting with the first sample tagged and follows through to the next sample tagged in sequence until the end of the batch.
- Unbiased sampling is managed by a consistent selection of the same side from each halved piece of cut core. The sampled core pieces pertaining to a given sample are placed in a heavy-duty transparent plastic bag and the remaining pieces are placed back into their original position in the core box. When working with the CorientR tool or the Reflex Act III RD system, the half containing the blue reference line is selected to be archived for future reference. The other half is put into the sample bag. Broken core (fault-gouge, fault-breccia) is sampled by scooping the right half into a sample bag and by leaving the remaining half in the core box. The paired sample tags are then torn with one tag stapled to the core box at the start of its sample interval and the other tag placed into the sample bag with the core sample.
- Sample bags are also labeled with the sample number written with black permanent marker and the open tops sealed with a plastic zip-tie (one direction).
- For blank samples, the core cutter(s) is/are required to scoop approximately 1 kg to 2 kg of gold-barren limestone gravel (assays <0.005 ppm gold) into a plastic sample bag as per the procedure outlined in the previous step.



- The core-logging geologist assigns certified gold reference materials, and the identification code is verified by the core-cutter(s). One pouch of standard material is placed into plastic sample bag. The name of the standard written on the pouch is erased by the core-cutter(s) before putting it into the bag to prevent identification by the assay laboratory. This prevents the assay laboratory from identifying the standard number and knowing the correct result.
- Numerical sequences of five samples, starting with the first sample, are packed into large rice bags and the open tops sealed with plastic zip-ties (one direction). The sample number range and incremental bag number are written on the rice bag, and this information is recorded on a rice-bag sample sheet. This operation is completed by the core cutting staff.
- All samples from a given drill hole are packaged in batches of 20 samples. Batches are generated for each drill hole and submitted to the ALS laboratories in Lebel-sur-Quévillon and Val-d'Or and BV laboratory in Timmins.
- A copy of the Sample Submittal Form and associated rice bag sample sheet are sent by email to the laboratory. When 100 samples (20 rice bags) are ready, they are packed and sent to the laboratory. The samples are then transported by an Osisko exclusive transporter and delivered directly to the ALS laboratory facility in Val-d'Or and/or Lebel-sur-Quévillon. Visual low-grade samples are delivered directly to BV shipment receiving in Timmins.

11.1.4 Lithochemical Samples Procedure

In addition to routine samples selected for gold analysis, an ancillary batch of representative samples were tested to better characterize the lithologies based on whole-rock geochemistry.

Whole-rock samples consisted of roughly 20-cm pieces of quarter core. The sample was selected to be the most representative piece of the rock unit being sampled (no veins, preferably weakly to non-mineralized material). A sample was taken at approximately every 30 m of core and samples were also taken to provide insight into the composition of unknown unit lithologies.

11.1.5 Analytical Methods

Historical analytical quality control measures were set in place by Fury in 2003 and 2004 and Noront in 2007. Details of these measures are outlined in previous technical reports produced for the property (El Rassi et al., 2011, 2012, 2014, and McLaughlin et al., 2015). The next sections describe the analytical methods performed during Osisko's period.



11.1.5.1 Samples for Gold Analysis

At the ALS laboratory, samples underwent conventional sample preparation procedures (ALS code PREP-31DH). Samples were crushed to a fineness of 90% passing 2 mm. A 1,000-g split of the crushed material was further comminuted to a sample pulp by pulverizing to 85% passing 75 µm. The pulverizer assembly (steel barrel, rings and puck) was cleaned with silica sand between samples. Most samples were submitted to the primary laboratory for analysis in batches of 20.

At BV, samples underwent conventional sample preparation procedures (BV code PRP90-250). Samples were crushed to 90% passing a 2-mm sieve. A 250-g split of crushed material was pulverized to 85% passing a 75-µm sieve.

Table 11-1 outlines the analysis methods used at both ALS and BV laboratories. Routine samples are analyzed with fire assay. If core-logging geologists identified visible gold, samples were sent for metallic screen analysis. Prepared pulp samples were assayed for gold using a fire assay procedure with atomic absorption finish at ALS and BV on 30 or 50 g pulp charges.

Table 11-1: Analytical methods for gold assays used by Osisko

Laboratory	Method	Method code	Sample weight (g)	Lower limit (ppm)	Upper limit (ppm)	Default over-limit method
ALS Minerals	Fire Assay with Atomic Absorption Finish	Au-AA23	30	0.005	10	Au-GRA21
		Au-AA24	50	0.005	10	Au-GRA22
		Au-AA25	30	0.01	100	Au-GRA21
		Au-AA26	50	0.01	100	Au-GRA22
	Fire Assay with Gravimetric Finish	Au-GRA21	30	0.05	10,000	--
		Au-GRA22	50	0.05	10,000	--
	Metallic Screen	Au-SCR21	1,000	0.05	10,000	--
		Au-SCR24	1,000	0.05	10,000	--
		Au-SCR24G	1,000	0.05	10,000	
		Au-CONSCR	1,000	0.07	1,000,000	
Bureau Veritas	Fire Assay with Atomic Absorption Finish	FA430	30	0.005	10	Gravimetric Method
		FA450	50	0.005	10	
	Fire Assay with Gravimetric Finish	FA530	30	0.9	--	--
		FA550	50	0.9	--	--
	Metallic Screen	FS652	50 - 500	0.05	--	--



At the request of Osisko, all samples exceeding 10 g/t Au using Au-AA26 or FA450 methods, or any samples containing high grade or visible gold were rerun with the metallic screen method (Au-SCR24, Au-SCR24G and FS652 methods). A 1,000-g split of the final prepared pulp is passed through a 100- μ m stainless steel screen to separate the oversize fraction. Any +100 μ m material remaining on the screen is retained and analyzed in its entirety by fire assay with gravimetric finish (Au-GRA22 and FA550 methods) and reported as the Au(+) fraction result. The 100 μ m fraction is homogenized and three 50 g sub-samples are analyzed by fire assay with Atomic Absorption (AA) finish. The average of the three AA results is taken and reported as the Au(-) fraction result. As of August 7, 2019, the -100 μ m fractions have been analyzed using gravimetric finish (Au-GRA22) rather than AA finish as ALS encountered difficulties with the fusing of Osisko high-grade samples. All three values are used in calculating the combined gold content of the plus and minus fractions using this equation.

$$\text{Au Total (ppm)} = \frac{((\text{Au(-) av ppm}) \times \text{Wt. Min(g)}) + (\text{Au(+) ppm} \times \text{Wt. Plus (g)})}{(\text{Wt. Min(g)} + \text{Wt. Plus (g)})}$$

11.1.5.2 Multi-elements Analysis

For the multi-elements (Ag, Al, As, B, Ba, Be, Bi, Ca, Cd, Ce, Co, Cr, Cs, Cu, Dy, Er, Eu, Fe, Ga, Gd, Ge, Hf, Hg, Ho, In, K, La, Li, Lu, Mg, Mn, Mo, Na, Nd, Ni, P, Pb, Pr, Rb, Re, S, Sb, Sc, Se, Sm, Sn, Sr, Ta, Tb, Te, Th, Ti, Tl, Tm, U, V, W, Yb, W, Zn), the samples were assayed by an atomic emission spectrometry procedure, ME-MS61 (Four acid digestion), ME-ICP61 (Four acid digestion) or ME-ICP41 (Aqua regia digestion) at ALS. ME-MS61 is primarily used since March 22, 2019. A prepared sample (0.25 g) is digested with perchloric, nitric and hydrofluoric acids. The residue is leached with dilute hydrochloric acid and diluted to volume. The final solution is then analyzed by inductively coupled plasma-atomic emission spectrometry. The analytical results are corrected for inter-element spectral interferences.

11.1.5.3 Lithochemical Samples

For lithochemical samples, the sample preparation method was the same as for routine samples. Whole-rock analysis was performed using a package that included major oxides (Al_2O_3 , BaO, CaO, Cr_2O_3 , Fe_2O_3 , K_2O , MgO, MnO, Na_2O , P_2O_5 , SiO_2 , SO_3 , SrO and TiO_2) loss on ignition ("LOI"), total oxides, plus Zr, Y and Nb. The analytical method was performed using a lithium borate fusion followed by an XRF finish (ALS codes ME-XRF26, ME-XRF06) A prepared sample (0.66 g) is added to 9.0 g of Lithium Borate Flux (35% - 65% $\text{Li}_2\text{B}_4\text{O}_7$ - LiBO_2), well mixed and fused in an auto fluxer between 1,050°C and 1,100°C. A flat molten glass disc is prepared from the resulting melt. This disc is then analyzed by XRF. The analytical method for Zr, Y and Nb (ALS codes Zr-XRF05, Y-XRF05, and Nb-XRF05) used a finely ground sample powder (10 g) mixed with few drops of liquid binder compressed in a pellet press. The pellet is dried then analyzed by XRF.



11.1.6 Quality Assurance and Quality Control (QA/QC) Programs

The exploration work conducted by Osisko was carried out using a QA/QC program following the industry's recognized best practices. The QP was not involved in the collecting and recording of the data, which Osisko employees performed.

QA/QC for the 2015 to 2022 drilling program consisted of a drill hole database audit, inserting quality control samples within all sample batches submitted for assaying and inter-laboratory check assays. Re-logging and re-sampling programs of core drilled by previous operators were conducted in 2016, 2017 and 2018 to better understand geological constraints on the Windfall deposit. In 2018, a representative batch of metallic screen samples (n = 2,270) previously analyzed without QC samples were quarter-split and sent for reanalysis with QC samples to validate previous Au results. Quarter-split results showed a good correlation with original half core results.

11.1.6.1 Field Assay Standards (Certified Reference Materials and Blanks)

The routine insertion of blank material monitors contamination of samples into the sample stream. The control procedure also included certified reference materials ("CRMs", or gold assay standards) to determine if there were assay problems with specific sample batches and possible long-term biases in the overall dataset. Blanks and CRMs go through the same sample preparation and analytical procedures as the core samples. They were assigned sample IDs at a frequency of at least one of each control type per range of 20 sample tag IDs. Each control type represents approximately 5% of the total batch depending on the total range of samples tags used (Table 11-2).

The results of the quality control samples were assessed by the Batch Authorization module of the Fusion software in DHLogger (Table 11-3).

**Table 11-2: Samples submitted to ALS for analysis along with primary samples
(April 28, 2015, to June 7, 2022)**

Type of sample	Quantity	%
Primary samples	1,351,373	88.03%
Field blanks	96,858	6.31%
Certified Reference Material	86,980	5.67%
Total	1,535,211	100.00%

Summary of samples submitted includes reanalysis and quarter-split samples.



Table 11-3: Current sample QA/QC statuses in DHLogger

ID	Description
Passed	Sample has passed QA/QC review, controlled by passed QA/QC samples and applied automatically by restrictive QA/QC default rules of the Batch Authorization module of DHLogger software.
QP Accepted	QP Accepted status is determined by Osisko's qualified persons. The decision to accept a failed QA/QC analysis result is based on a set of QA/QC rules following industry QA/QC best practices. Examples of QP Accepted results include: <ul style="list-style-type: none">▪ Suite of samples affected includes no anomalies.▪ Suite of samples affected includes minor and/or isolated sub- low-grade anomalies.▪ Au contamination on blank QC sample with no impact on other samples.
Failed	Failed status is applied automatically by the Batch_Authorization module of DHLogger software when Osisko's restrictive QA/QC rules are not met. All Failed statuses are revised and approved by Osisko's qualified persons and trigger request for reassay or quarter-split samples. Examples of Failed results include: <ul style="list-style-type: none">▪ Surpassed maximum/minimum defined standard control values (± 3 SD).▪ Possible Au contamination and quarter-split request.
Failed NSA	Failed Non-Significant Assay ("Failed NSA") status indicates Failed assay result with Au value less than 0.5 ppm. No reassay has been requested.
No QA/QC	No QA/QC status is applied when a sample is not associated with a least 1 CRM / 1 Blank per batch of 20 samples in the certificates and/or the QA/QC is not following Osisko's set of QA/QC rules.
No Results	"No Results" status is rare and is applied in two scenarios: <ul style="list-style-type: none">▪ When the assay result returns empty in the certificate after completing every step in the sampling process (logging, sampling, core-splitting). Most of these "No Results" statuses occur when the certificate indicates NSS (Non-Sufficient material Sample), or when problems occur after core-splitting or at the laboratory.▪ During various compilation work conducted by Osisko, sample numbers were found associated with historical drill holes but were unable to locate the associated assay certificate and results.
Cancelled	Cancelled status is rare and is applied when the sample number has been recorded into the database during core logging but was not cut at the core-splitting step. Various reasons can be involved.



11.1.6.1.1 Blanks

The blank is a coarse crush blank material (limestone gravel) sourced from a regional hardware store. The blank material has not changed since 2014. The blank is submitted with samples for crushing and pulverizing to determine if there has been contamination or sample cross-contamination during the preparation. Elevated values for blanks may also indicate sources of contamination in the fire assay procedure (contaminated reagents or crucibles) or sample solution carry-over during instrumental finish.

From April 28, 2015, to June 7, 2022, there were a total of 96,858 blanks submitted to ALS and BV with the samples (Table 11-4). Blank materials were considered failed when the returned gold value exceeded 10x the lower detection limit of the analytical method (Table 11-1). A general guideline for success on a contamination quality control program is a success rate of 90% of blanks showing no contamination exceeding the acceptable limits. Table 11-4 and Figure 11-1 to Figure 11-8 summarize the performance of the blanks. Depending on the method used during the analyses, on average, 98.22% of the blanks analyzed passed the process (Table 11-4).

All failed samples were investigated, and appropriate action was taken to rectify the abnormal results. Samples did not require follow-up where contamination did not affect succeeding samples or where the batch did not include samples with significant results. If carry-over from the previous gold sample at the preparation stage was suspected to affect subsequent samples, a quarter-split of the remaining core was sent for reanalysis with new QC samples. Other actions on blank fails are discussed further in this section (see comments for Monitoring Contamination).



Table 11-4: Blanks submitted for analysis along with routine samples
(April 28, 2015, to June 7, 2022)

Method	Lab	Qty Inserted	Expected Au Value	Fail Value	Osisko Mean Grade (ppm)	Osisko Min (ppm)	Osisko Max (ppm)	Failed	% Passing
AU_PPM_AA24	ALS	7,380	0	0.05	0.004	0.0025	9.42	10	99.86%
AU_PPM_AA26	ALS	68,355	0	0.1	0.02	0.005	35.7	1,072	98.43%
AU_PPM_FA450	BV	12,779	0	0.05	0.004	0.0025	10	13	99.84%
AU_PPM_FA550	BV	2	0	0.5	0.45	0.45	0.45	0	100.00%
AU_PPM_GRA22	ALS	3,758	0	0.5	0.309	0.025	54.1	342	90.90%
AUTOTAL_PPM_FS652	BV	257	0	0.5	0.027	0.025	0.1	0	100%
AUTOTAL_PPM_SCR24	ALS	2,461	0	0.5	0.17	0.025	35.2	103	95.81%
AUTOTAL_PPM_SCR24G	ALS	1,866	0	0.5	0.57	0.025	255	183	90.19%
Total		96,858						1,723	98.22%



Blank_AU_PPM_AA24
 Summary Statistics

Observed Values	
Number of Samples	7380
Mean	0.004

	#	%
Failed	10	0.14%
Passed	7370	99.86%

Gross Outliers	
Greater than 0.1 ppm (20xDL)	
Number of Samples	4

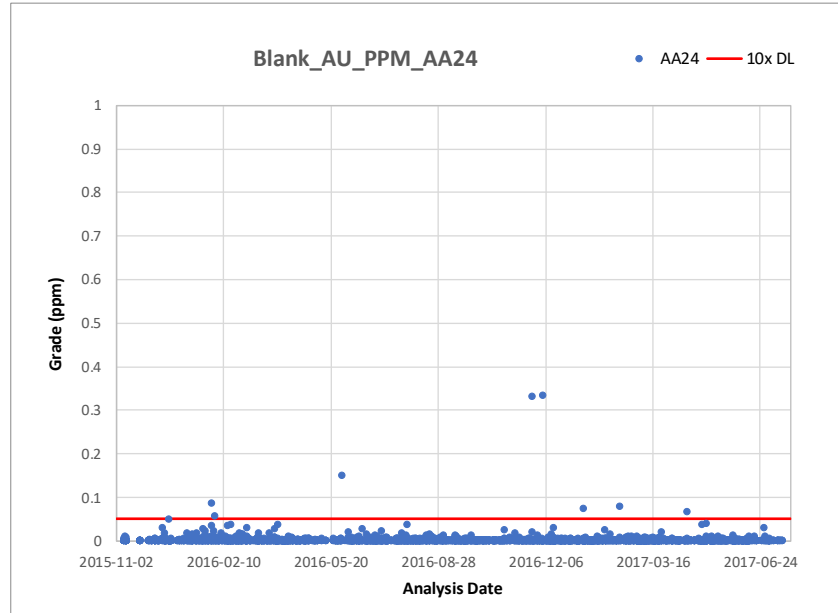

Figure 11-1: Time series plot for blank samples assayed by ALS (AA24 Method)
 Failure limits set at 0.05 g/t Au (10x detection limit)

Blank_AU_PPM_AA26
 Summary Statistics

Observed Values	
Number of Samples	68355
Mean	0.019

	#	%
Failed	1072	1.57%
Passed	67283	98.43%

Gross Outliers	
Greater than 0.2 ppm (20xDL)	
Number of Samples	99

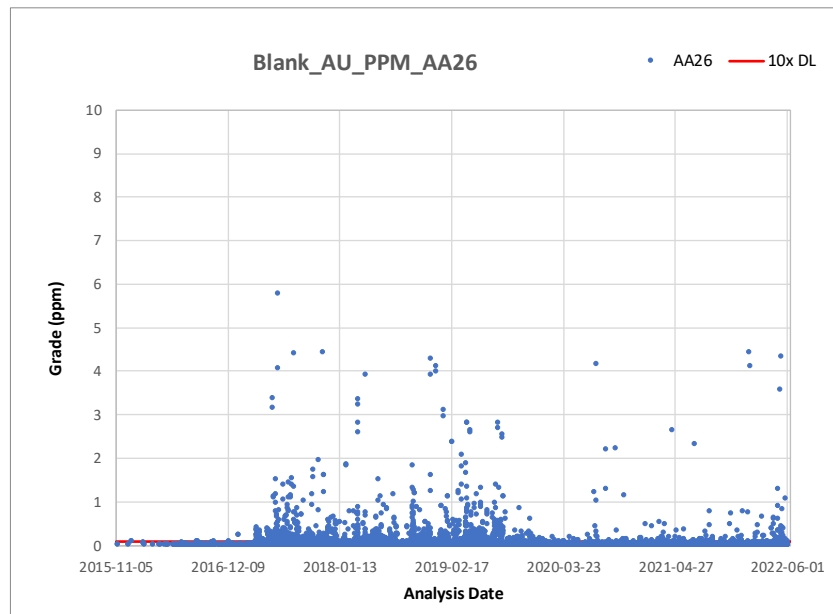

Figure 11-2: Time series plot for blank samples assayed by ALS (AA26 Method)
 Failure limits set at 0.1 g/t Au (10x detection limit)



Blank_AU_PPM_FA450
 Summary Statistics

Observed Values	
Number of Samples	12779
Mean	0.004

	#	%
Failed	13	0.10%
Passed	12766	99.90%

Gross Outliers	
Greater than 0.1 ppm (20xDL)	
Number of Samples	7

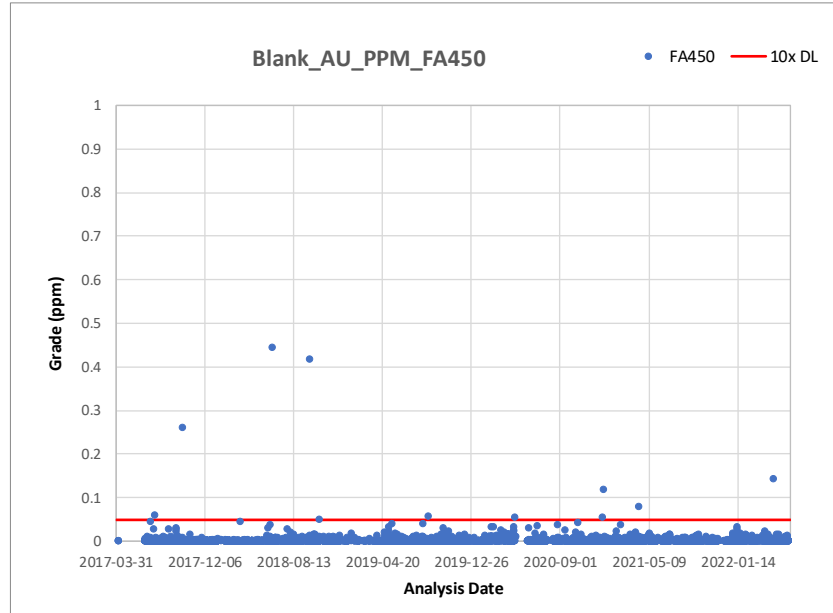

Figure 11-3: Time series plot for blank samples assayed by Bureau Veritas (FA450 Method)
 Failure limits set at 0.05 g/t Au (10x detection limit)

Blank_AU_PPM_FA550
 Summary Statistics

Observed Values	
Number of Samples	2
Mean	0.450

	#	%
Failed	0	0.00%
Passed	2	100.00%

Gross Outliers	
Greater than 1 ppm (20xDL)	
Number of Samples	0

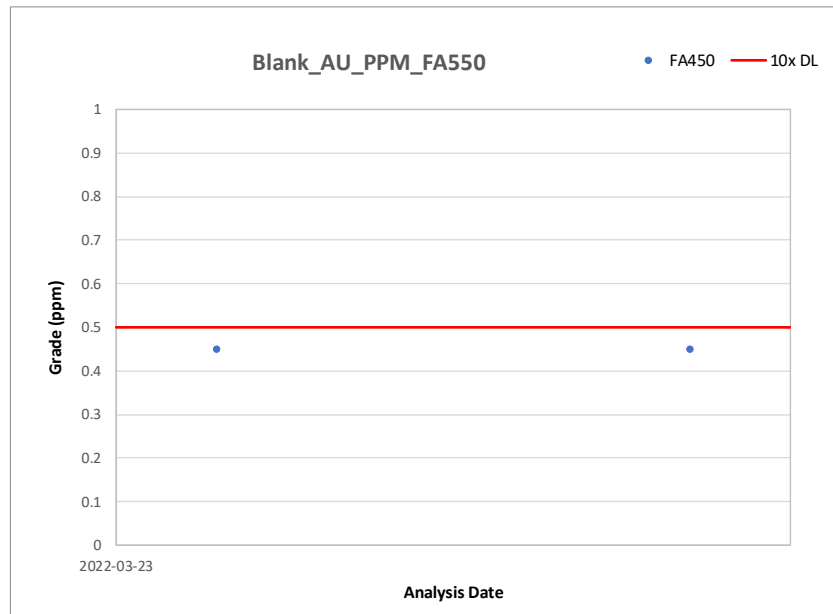

Figure 11-4: Time series plot for blank samples assayed by Bureau Veritas (FA550 Method)
 Failure limits set at 0.5 g/t Au (close to half detection limit of 0.9 g/t Au)



Blank_AU_PPM_GRA22
 Summary Statistics

Observed Values	
Number of Samples	3758
Mean	0.310

	#	%
Failed	342	9.10%
Passed	3416	90.90%

Gross Outliers	
Greater than 1 ppm (20x DL)	
Number of Samples	157

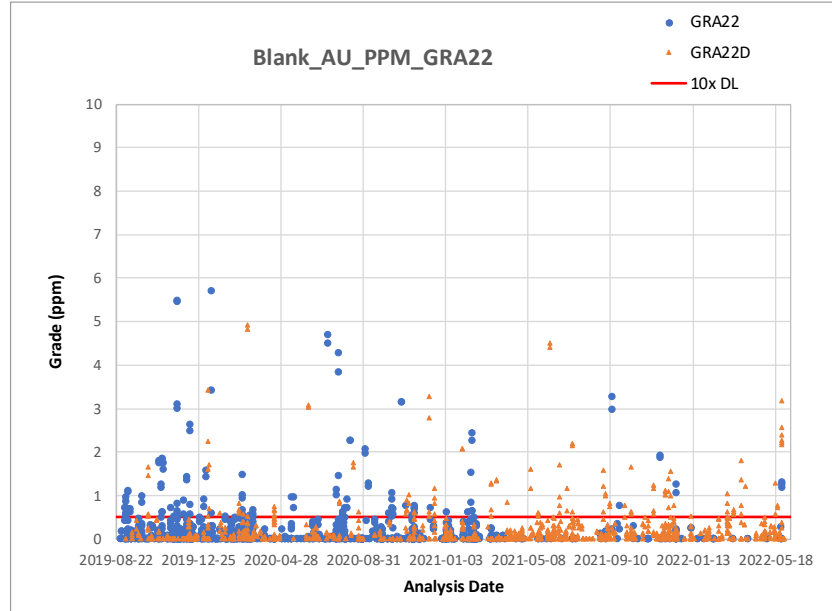

Figure 11-5: Time series plot for blank samples assayed by ALS (GRA22 Method)
 Failure limits set at 0.5 g/t Au (10x detection limit)

Blank_AUTOTAL_GPT_FS652
 Summary Statistics

Observed Values	
Number of Samples	257
Mean	0.026

	#	%
Failed	0	0%
Passed	257	100%

Gross Outliers	
Greater than 1 ppm (20x DL)	
Number of Samples	0

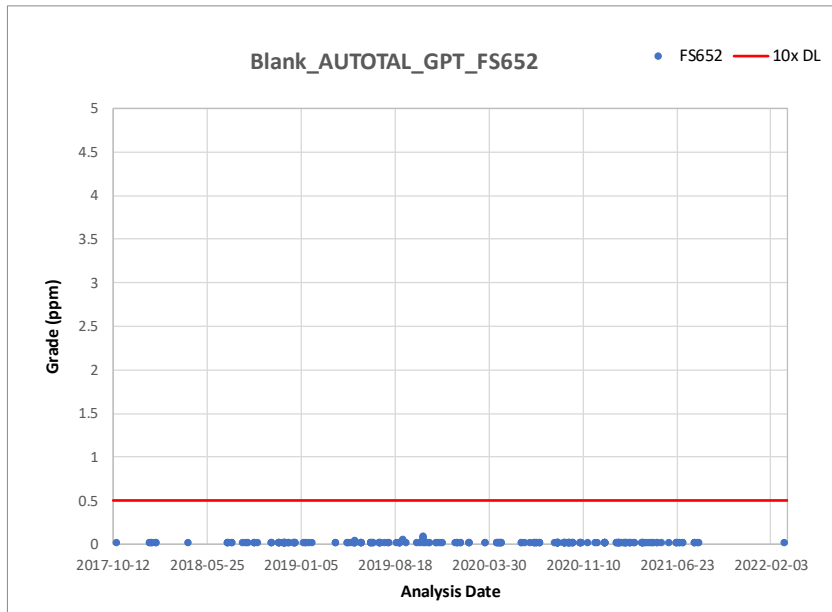

Figure 11-6: Time series plot for blank samples assayed by Bureau Veritas (FS652 Method)
 Failure limits set at 0.5 g/t Au (10x detection limit)



Blank_AUTOTAL_PPM_SCR24
 Summary Statistics

Observed Values	
Number of Samples	2461
Mean	0.170

	#	%
Failed	103	4.19%
Passed	2358	95.81%

Gross Outliers	
Greater than 1 ppm (20x DL)	
Number of Samples	53

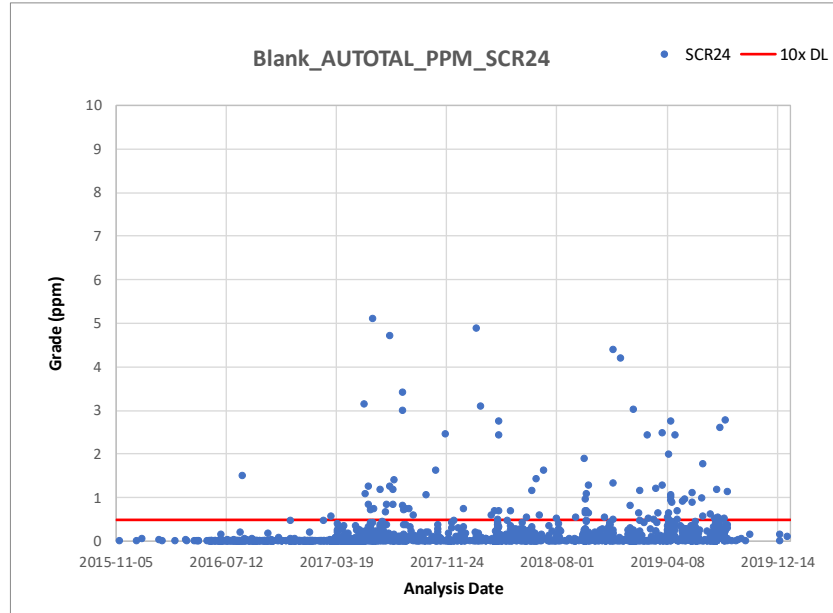

Figure 11-7: Time series plot for blank samples assayed by ALS (SCR24 Method)
 Failure limits set at 0.5 g/t Au (10x detection limit)

Blank_AUTOTAL_PPM_SCR24G
 Summary Statistics

Observed Values	
Number of Samples	1866
Mean	0.574

	#	%
Failed	183	9.81%
Passed	1683	90.19%

Gross Outliers	
Greater than 1 ppm (20x DL)	
Number of Samples	97

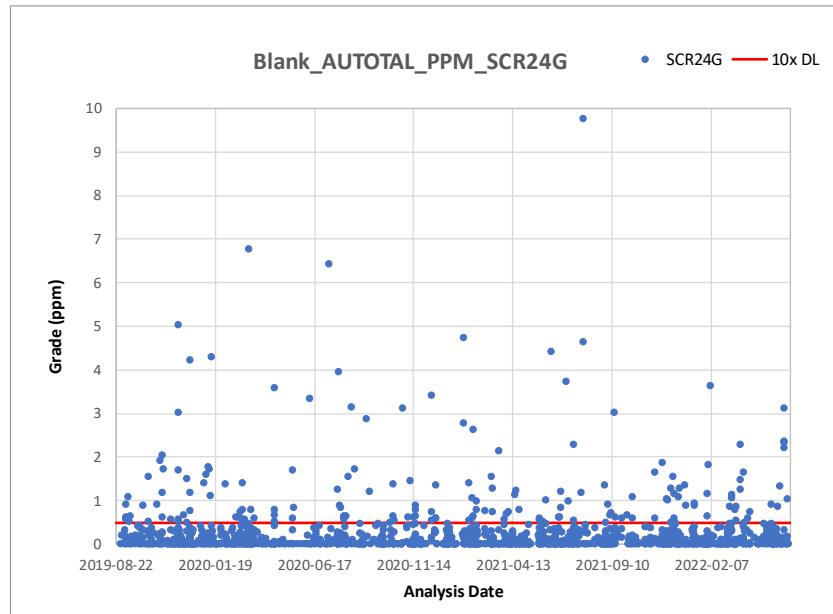

Figure 11-8: Time series plot for blank samples assayed by ALS (SCR24G Method)
 Failure limits set at 0.5 g/t Au (10x detection limit)



Comments for Monitoring Contamination

Given the high gold values and the amount of visible gold at Windfall, blanks are systematically inserted after each sample that could potentially cause contamination. When the potential for contamination is high, Osisko asks the laboratory for additional cleaning processes of the crusher and sprayer before passing the blank. Despite these precautions, there are still cases of contamination.

A higher number of failures can be seen beginning from March 2017 onwards. A possible cause for the increase of failures is the sharp rise in the drilling rate during March 2017 (from 12 to 24 drills) associated with the increase of high-grade results provided by the Lynx discovery. The massive influx of core managed and logged by Osisko's personnel and the samples treated by ALS for this period could explain the quality control performance. In reviewing failed blanks, the majority did not require follow-up as they were not found to affect subsequent samples or were not associated with samples of significant results.

Osisko is aware of this problem and has taken action accordingly. In all cases, each rejected blank value is tracked by Osisko to validate and rectify the problem. Most exceedances are due to cross-contamination between two samples. Inversion of a blank by a CRM and an erroneous entry in the database are also possible errors. In cases where a high-grade sample caused a blank failure and a clear contamination trail was identified, succeeding affected samples, along with the failed blank control would be resampled using quarter-split method and analyzed. In the case where the contamination source and/or contamination trail is not identifiable, all affected samples preceding and succeeding the failed blank would be quarter-split and analyzed. The process is applied until an uncontaminated blank or a value below 10x the detection limit is obtained.

11.1.6.1.2 Certified Reference Materials

The insertion of CRMs monitored accuracy and precision at the rate of once every 20 samples. A total of 87,029 CRMs samples (of 51 different CRMs) were submitted from April 28, 2015, to June 7, 2022 (Table 11-2 and Table 11-5). CRMs cover a range of gold grades from 0.2 g/t to 15.7 g/t. Standards are obtained from Ore Research & Exploration Pty Ltd. ("OREAS").

Most CRMs have enough values to be represented on a control chart. Control charts showing analytical concentration values against warning limits (horizontal lines) have been prepared for each standard. Figure 11-9 to Figure 11-12 are representative charts of AA26 CRM performance at varying grades.



Standard materials were considered as failed when a gold result exceeded three standard deviations (“SD”) (± 3 SD) beyond the expected value (Table 11-5). A total of 4,048 events were recorded and commented upon when the analytical values of the CRM fell the ± 3 SD control limits. Failed CRMs are flagged to the laboratory with instructions to reassay all the pulps of the certificates (20 samples) affected with failed CRMs. If the analytical value fell between ± 2 SD and ± 3 SD, no reassaying was performed. If the analytical value exceeded the ± 3 SD control limits, systematic reassaying was not always requested, particularly if the value was on the threshold of the limits. However, for mineralized zones, resampling was systematically performed. In cases where the analytical value clearly exceeded the ± 3 SD control limit, reassaying was requested.

Table 11-5: Certified standards values, 95% confidence limits for gold reference material (ppm) with fire assay (April 28, 2015, to June 7, 2022)

Constituent (CRM)	Supplier	Certified Au value (ppm)	SD	95% Confidence limits	
				Low	High
OREAS 12a	OREAS	11.79	0.24	11.68	11.89
OREAS 15d	OREAS	1.559	0.042	1.54	1.579
OREAS 16a	OREAS	1.81	0.06	1.78	1.84
OREAS 19a	OREAS	5.49	0.1	5.45	5.54
OREAS 200	OREAS	0.34	0.012	0.336	0.345
OREAS 201	OREAS	0.514	0.017	0.507	0.521
OREAS 202	OREAS	0.752	0.026	0.742	0.763
OREAS 203	OREAS	0.871	0.03	0.859	0.884
OREAS 205	OREAS	1.244	0.053	1.221	1.267
OREAS 208	OREAS	9.248	0.438	9.052	9.444
OREAS 209	OREAS	1.58	0.044	1.56	1.59
OREAS 210	OREAS	5.49	0.152	5.42	5.55
OREAS 211	OREAS	0.768	0.027	0.758	0.777
OREAS 215	OREAS	3.54	0.097	3.51	3.57
OREAS 216b	OREAS	6.66	0.158	6.61	6.71
OREAS 217	OREAS	0.338	0.01	0.334	0.341
OREAS 218	OREAS	0.531	0.017	0.526	0.536
OREAS 219	OREAS	0.76	0.024	0.753	0.768
OREAS 220	OREAS	0.866	0.02	0.86	0.873
OREAS 221	OREAS	1.062	0.036	1.051	1.074
OREAS 222	OREAS	1.223	0.033	1.211	1.234
OREAS 223	OREAS	1.78	0.045	1.765	1.795
OREAS 224	OREAS	2.154	0.053	2.136	2.171



Constituent (CRM)	Supplier	Certified Au value (ppm)	SD	95% Confidence limits	
				Low	High
OREAS 226	OREAS	5.45	0.126	5.41	5.49
OREAS 228	OREAS	8.73	0.279	8.63	8.83
OREAS 228b	OREAS	8.57	0.199	8.51	8.63
OREAS 229	OREAS	12.11	0.206	12.05	12.18
OREAS 229b	OREAS	11.95	0.288	11.86	12.04
OREAS 232	OREAS	0.902	0.023	0.895	0.909
OREAS 235	OREAS	1.59	0.038	1.57	1.60
OREAS 239	OREAS	3.55	0.086	3.52	3.58
OREAS 240	OREAS	5.51	0.139	5.47	5.56
OREAS 501b	OREAS	0.248	0.01	0.244	0.251
OREAS 502b	OREAS	0.495	0.015	0.489	0.501
OREAS 504b	OREAS	1.61	0.04	1.59	1.62
OREAS 600	OREAS	0.2	0.006	0.198	0.202
OREAS 601	OREAS	0.78	0.031	0.769	0.791
OREAS 603	OREAS	5.18	0.151	5.12	5.23
OREAS 607	OREAS	0.69	0.024	0.681	0.699
OREAS 608	OREAS	1.21	0.039	1.20	1.23
OREAS 609	OREAS	5.16	0.139	5.11	5.2
OREAS 611	OREAS	15.7	0.601	15.47	15.93
OREAS 60c	OREAS	2.47	0.08	2.44	2.5
OREAS 60d	OREAS	2.47	0.079	2.44	2.5
OREAS 61d	OREAS	4.76	0.14	4.69	4.83
OREAS 61e	OREAS	4.43	0.15	4.38	4.48
OREAS 62c	OREAS	8.79	0.21	8.69	8.88
OREAS 62d	OREAS	10.5	0.33	10.36	10.64
OREAS 62e	OREAS	9.13	0.41	8.97	9.3
OREAS 62f	OREAS	9.71	0.239	9.63	9.8
OREAS 65a	OREAS	0.52	0.017	0.513	0.528



OREAS 218_AU_PPM_AA26
 Summary Statistics

Expected Values	
Mean	0.531
Standard Deviation	0.017
Coefficient of Variation (CV)	3.20%

Observed Values	
Number of Samples	6671
Mean	0.531
Standard Deviation	0.017
Coefficient of Variation (CV)	3.18%
Failed	165
Failure %	2%
% Within 3 SD of Certified Mean	3%
% Within 2 SD of Certified Mean	24%
% Within 1 SD of Certified Mean	71%

Gross Outliers	
Less than 0.446 ppm and greater than 0.616 ppm	
Number of Samples	83

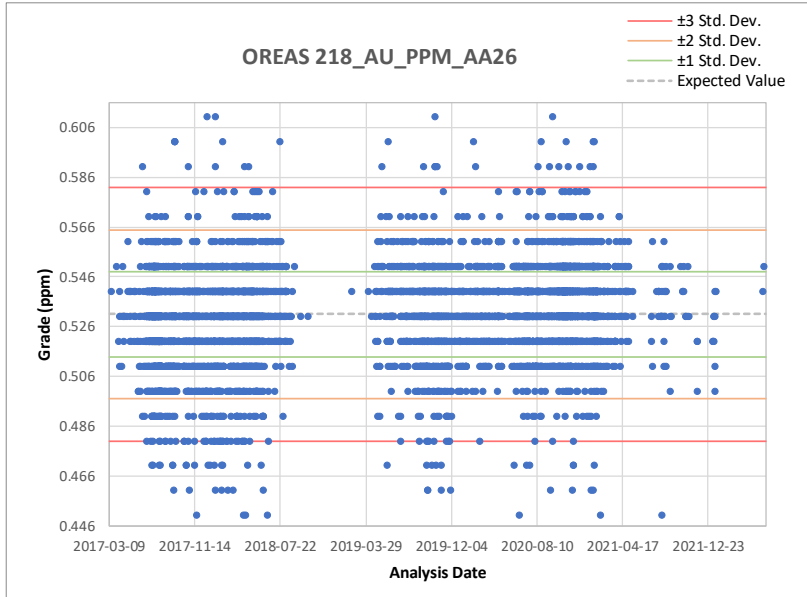

Figure 11-9: Results of standard OREAS 218 using AA26 Method

OREAS 221_AU_PPM_AA26
 Summary Statistics

Expected Values	
Mean	1.062
Standard Deviation	0.036
Coefficient of Variation (CV)	3.39%

Observed Values	
Number of Samples	4507
Mean	1.060
Standard Deviation	0.032
Coefficient of Variation (CV)	3.04%
Failed	101
Failure %	2%
% Within 3 SD of Certified Mean	2%
% Within 2 SD of Certified Mean	17%
% Within 1 SD of Certified Mean	79%

Gross Outliers	
Less than 0.882 ppm and greater than 1.242 ppm	
Number of Samples	52

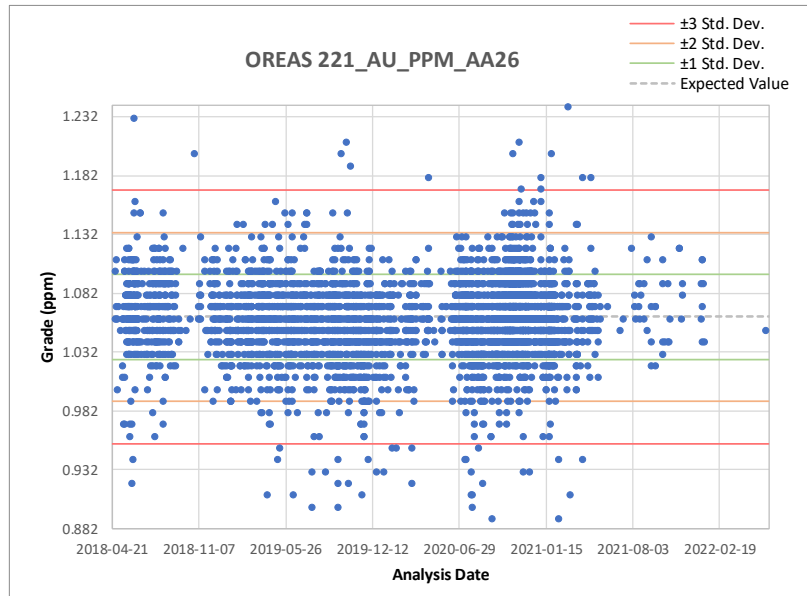

Figure 11-10: Results of standard OREAS 221 using AA26 Method



OREAS 239_AU_PPM_AA26
 Summary Statistics

Expected Values	
Mean	3.550
Standard Deviation	0.086
Coefficient of Variation (CV)	2.42%

Observed Values	
Number of Samples	2700
Mean	3.545
Standard Deviation	0.088
Coefficient of Variation (CV)	2.47%
Failed	72
Failure %	3%
% Within 3 SD of Certified Mean	3%
% Within 2 SD of Certified Mean	23%
% Within 1 SD of Certified Mean	71%

Gross Outliers	
Less than 3.12 ppm and greater than 3.98 ppm	
Number of Samples	31

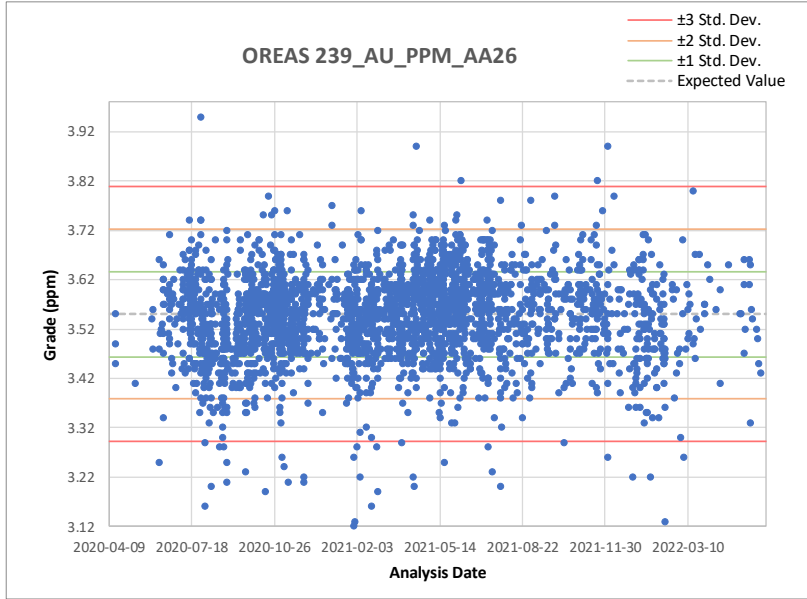

Figure 11-11: Results of standard OREAS 239 using AA26 Method

OREAS 228_AU_PPM_AA26
 Summary Statistics

Expected Values	
Mean	8.730
Standard Deviation	0.279
Coefficient of Variation (CV)	3.20%

Observed Values	
Number of Samples	1226
Mean	8.542
Standard Deviation	0.250
Coefficient of Variation (CV)	2.93%
Failed	61
Failure %	5%
% Within 3 SD of Certified Mean	4%
% Within 2 SD of Certified Mean	24%
% Within 1 SD of Certified Mean	67%

Gross Outliers	
Less than 7.335 ppm and greater than 10.125 ppm	
Number of Samples	32

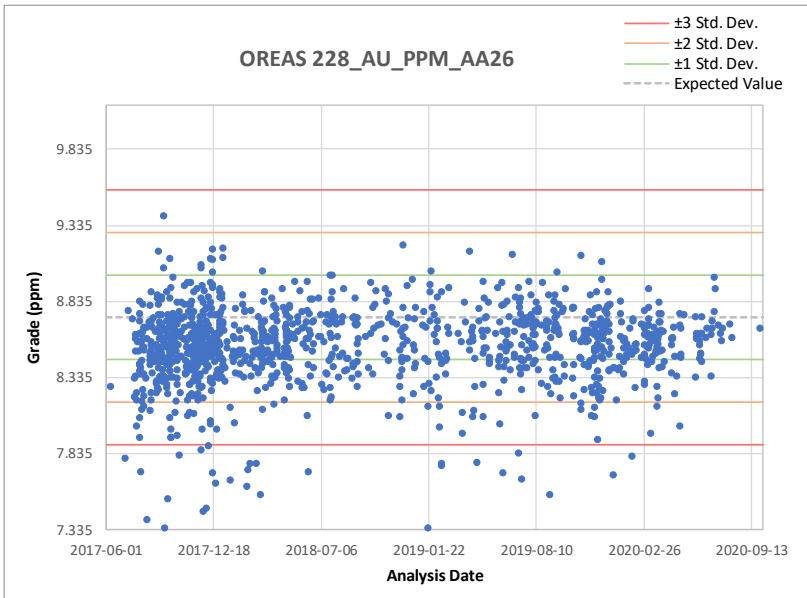

Figure 11-12: Results of standard OREAS 228 using AA26 Method



Comments for Monitoring Accuracy and Precision

The accuracy of the result (as a percentage of error) is measured as the difference between the average of the standard and the value assigned for the standard; gross outliers are excluded from this operation. For a laboratory, good accuracy constitutes the ability to give results as near as possible to the expected value.

The CRMs generally report within $\pm 10\%$ of the expected value and within three standard deviations. The mean accuracy of all inserted reference materials is 0.50%. Most results for the standards range from precise ($<3\%$) to typical, according to standard industry precision criteria (3% to 5%). Accuracy over 5% concerns only six CRMs with an insignificant number of samples.

The precision of the result (as a percentage) is represented by the value dispersion of the standard versus its average. Good precision for a laboratory constitutes the ability to repeat results with the smallest standard deviation possible. The mean precision of all inserted CRMs is 3.11%. These results are considered precise according to the standard industry precision criteria (3% to 5%).

11.1.6.1.3 Umpire Check Assays

A component of the QA/QC program included umpire check assays or the determination of the analytical precision (repeatability) of the original gold assay data from the laboratory. ALS pulps were submitted to BV for inter-laboratory check assays (Figure 11-13). The assays for the pulp duplicates provide an estimate of the reproducibility related to the uncertainties inherent in the analytical method and the homogeneity of the pulps. The precision or relative percent difference calculated for the pulp duplicates indicates whether pulverizing specifications should be changed and/or whether alternative methods, such as screen metallics assays for gold, should be considered.

Prior to statistical analysis and plotting of the duplicates, outliers were removed from the dataset. Outliers are extreme values that can have a disproportionate influence on precision estimates based on duplicate data. In this case, only gross outliers ($\pm 300\%$ difference) were manually removed as they could have been the result of human error. In addition, to prevent unwanted bias due to reproducibility issues on samples with very low grades or grades close to the detection limits, only samples above the lower limit value of 0.005 ppm were used.

The original ALS 5,922, pulps and BV pulps duplicates assays are plotted in Figure 11-13. Duplicate sets are presented as log-scaled plots to provide detail at lower concentrations. The scatter plot of pulps yielded a linear regression slope of 0.98 and a determination coefficient of 96%, which indicates that the average grade is close to the average original grade and there is good reproducibility.

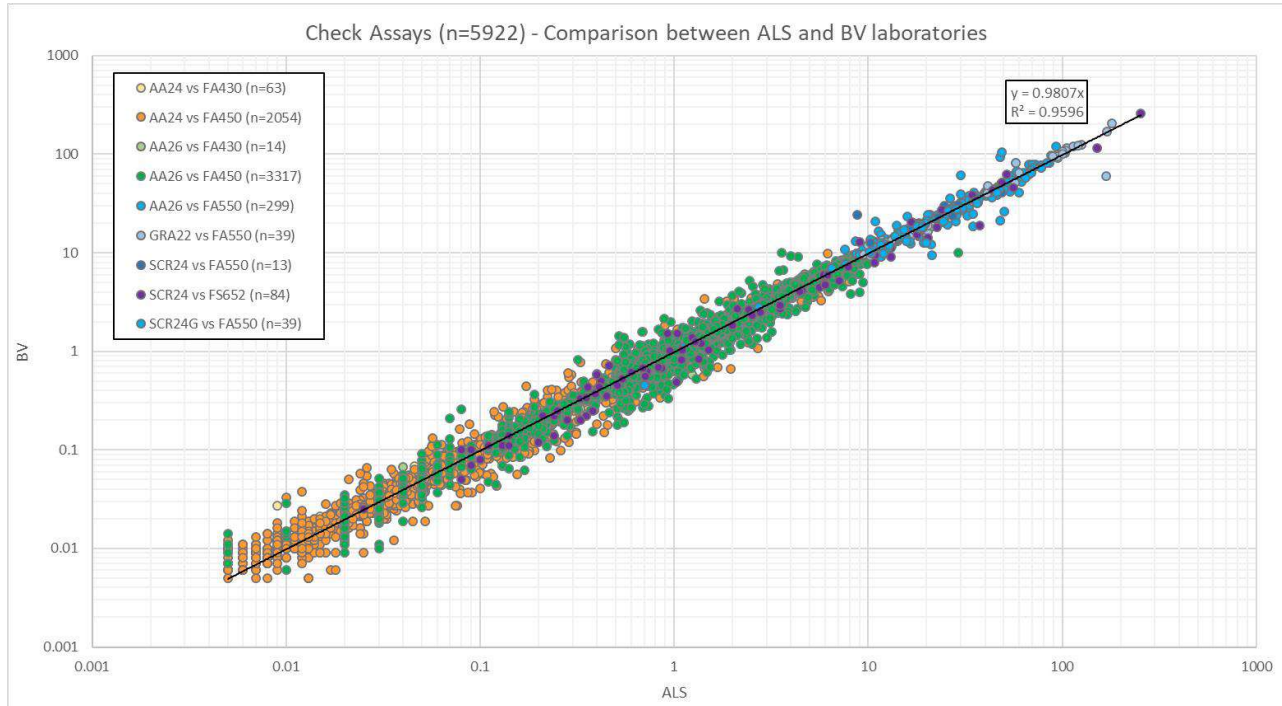

Figure 11-13: Post 2014 mineral resource estimate laboratory pulp duplicates for gold (g/t)
Values ≤ 0.005 ppm and outliers are removed from trend analysis

11.1.6.1.4 Density and Specific Gravity

Density and Specific gravity (“SG”) are measured on a selection of samples, mostly within the mineralized zones. For the resource estimate, the database contains 158,610 samples with SG/Density values for 1,351,373 assay samples. Four different protocols have been used: GRA08b, GRA08, SPG04 and ELEDED.

SG was measured by pycnometry by ALS Minerals (ALS code OA-GRA08b) and BV in Timmins (BV code SPG04).

In 2013, Eagle Hill conducted an internal test that compared specific gravity measurements using a water displacement method (GRA08 ALS method) and those obtained from pycnometry on pulverized material (GRA08B ALS method). The test results showed some variability when comparing the SG values of approximately 15 cm-long sample pieces. However, when the results from a number of these smaller pieces taken from one sample interval were averaged, the resulting SG data compared favourably to those data obtained from the ALS pycnometry.



In 2018, Osisko began an internal bulk density measurement program by the electronic densimeter method (ELEDEN method). The program has been completed on the Lynx zone, the Main zone and other sub-zones. Within the database, excluding outliers, there are 1,234 internal bulk density measurements from Eagle Hill and Osisko, along with laboratory SG comparable associated with resource samples. Table 11-6 shows basic statistics between methods, with gross outliers removed. Figure 11-14 shows the correlation between laboratory and internal bulk density measurements.

**Table 11-6: Summary statistics between specific gravity GRA08b and bulk density methods
(n = 1,234)**

Statistic	GRA08b (Unity)	Bulk Density (g/cm ³)
Min	2.47	2.32
Max	4.38	4.28
Mean	2.83	2.83
Median	2.81	2.80
Std Dev	0.13	0.12

Comments on Density

The mean density between the two methods is identical at 2.83 (Table 11-6). The SG diagram trend indicates that laboratory measurements below 3.0 tend to be lower compared to internal measurements (Figure 11-14).

The slight difference in results between the two methods is not surprising. With the pycnometer method, the material is a homogenized pulp from the entire interval assayed. The electronic densimeter method uses a 10- to 15-cm long core sample and considers the porosity that is destroyed when grinding with the pycnometer method.

The QP considers the density results to be adequate for the preparation of a mineral resource estimate. The average density values are in line with the results expected of this deposit type.

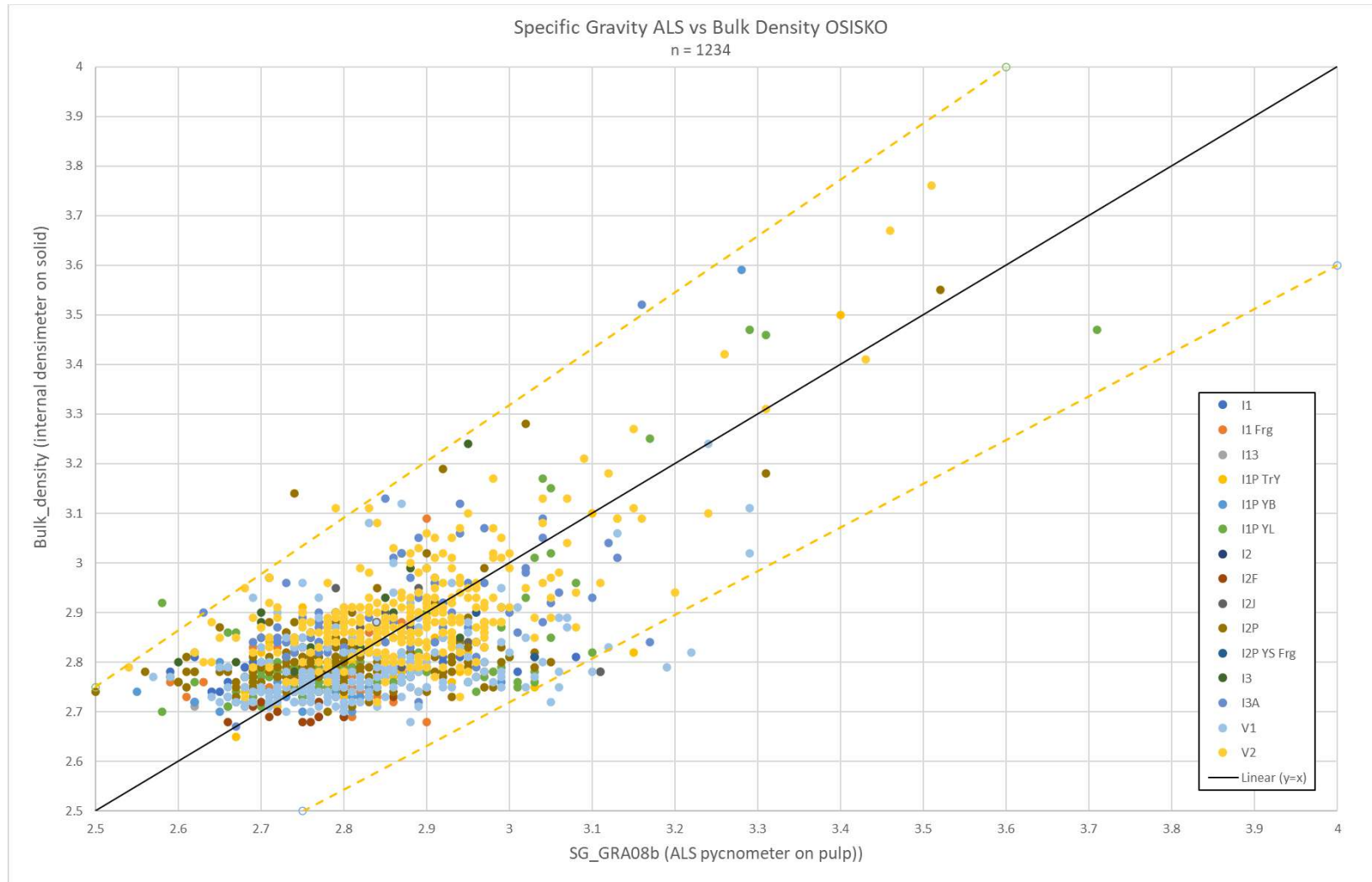

Figure 11-14: Laboratory specific gravity (GRA08b) and internal bulk density measurement correlation (Eagle Hill and Osisko)
Specific gravity measurements are coded by rock type



11.1.6.2 Laboratory Quality Assurance and Quality Control

11.1.6.2.1 ALS Minerals

ALS follows an in-house QA/QC program. To ensure quality control at the sample preparation stage, ALS monitors the fineness of crushing and pulverizing according to the method specifications and inserts one sample preparation duplicate per batch of 50, taken from coarse crushed material. At the analytical stage, ALS runs its own blanks, reference materials and pulp duplicates. The frequency of analytical quality control can be seen in Table 11-7. Three months of pulp duplicate data from the most frequently used assay method, Au-AA26, taken from the ALS Webtrieve™ system, is plotted in Figure 11-15.

Table 11-7: ALS analytical quality control – Reference materials, blanks and duplicates

Rack size	Method	Quality control sample allocation
20	Specialty methods including specific gravity, bulk density and acid insolubility	2 standards, 1 duplicate, 1 blank
28	Specialty fire assay, assay-grade, umpire and concentrate methods	1 standard, 1 duplicate, 1 blank
39	XRF methods 2 standards, 1 duplicate, 1 blank	1 standard, 1 duplicate, 1 blank
40	Regular AAS, ICP-AES and ICP-MS methods	2 standards, 1 duplicate, 1 blank
84	Regular fire assay methods	2 standards, 3 duplicates, 1 blank

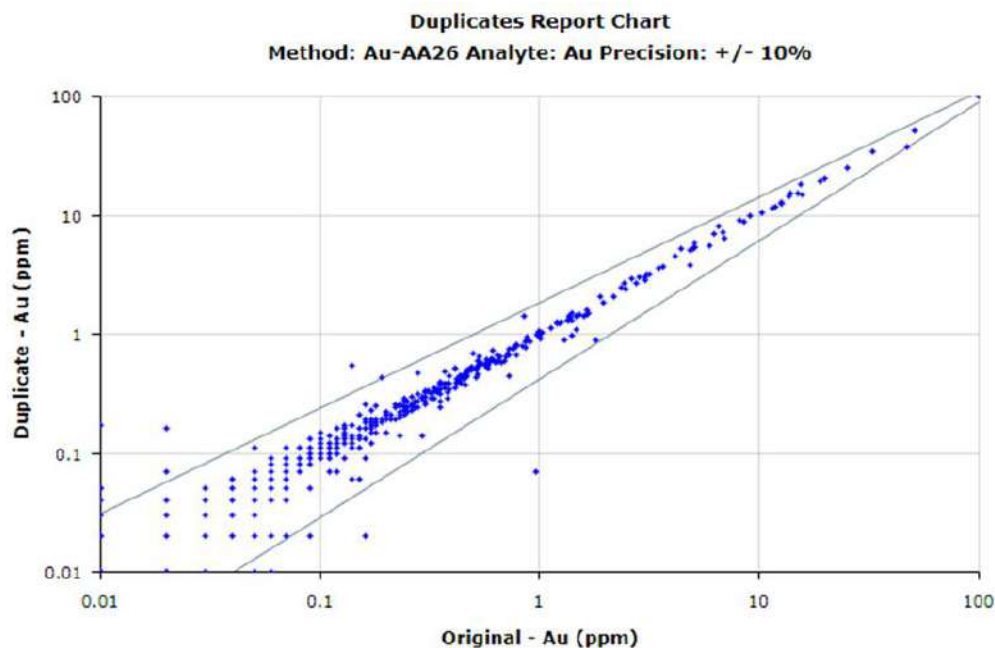

Figure 11-15: ALS pulp duplicates for Windfall samples (AA26)
WINABO: Client code at ALS for Windfall samples



11.1.6.2.2 Bureau Veritas

BV conducts its own internal laboratory quality control program. Laboratory analytical batches typically consist of 40 or 84 samples, with 10% to 15% laboratory-inserted control materials. At the sample preparation stage for rock and drill core samples submitted, granite or quartz sample-prep blanks are carried through all stages of preparation and analysis to confirm the cleaning protocols suffice. Reject duplicates (“DUP”) of -10 mesh are created during the preparation stage and analyzed along with samples. Internal analytical controls include pulp replicates (“REP”) to monitor analytical precision, reagent blanks (“BLK”) to measure background and CRMs (“STD”). Pulp duplicates of FA450 data from the BV WebAccess system is shown in Table 11-8 and Figure 11-16.

Table 11-8: Bureau Veritas analytical quality control – Reference materials, blanks and duplicates

Internal quality control	Analytical lab batch of 40	Fire assay lab batch of 84
Analytical blank	1	2
Pulp replicate	1	2
Preparation duplicate	1	2
Reference material	2	3

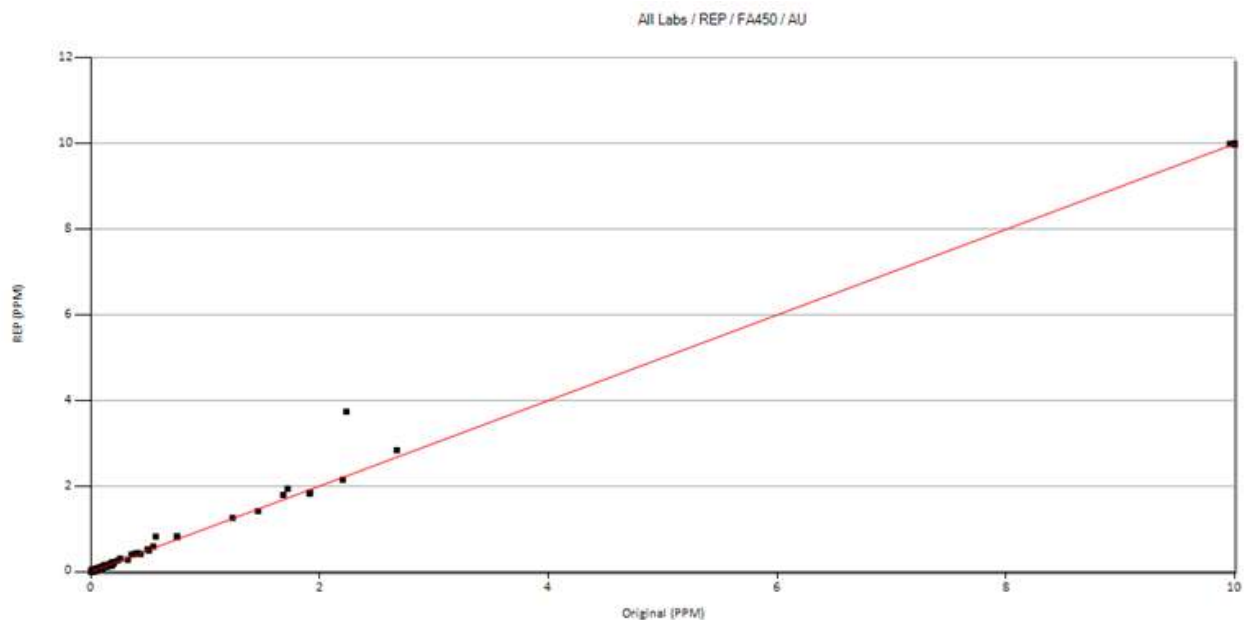

Figure 11-16: Bureau Veritas pulp replicates (Method FA450)



11.1.6.3 Final Gold Value

In cases where multiple analysis methods were used to analyze gold content, a priority sequence was used to identify the final gold value to be used in resource estimation. The ranking priority is listed in Table 11-9. The formula used to select the final gold value for the database will choose the highest priority rank that has passed QA/QC; i.e., should AuTotal_ppm_SCR24 fail QA/QC, but the lower-ranked Au_ppm_AA24 passed QA/QC, the final gold value would be sourced from the Au_ppm_AA24 method.

Table 11-9: Gold method priority ranking

Ranking	Method code	Laboratory
1	AuTotal_ppm_SCR24	ALS Minerals
2	AuTotal_ppm_SCR24g	ALS Minerals
3	AuTotal_ppm_SCR21	ALS Minerals
4	AuTotal_ppm_CONSCR	ALS Minerals
5	AuTotal_gpt_FS652	Bureau Veritas
6	Au_ppm_GRA22	ALS Minerals
7	Au_ppm_GRA21	ALS Minerals
8	Au_ppm_AA26	ALS Minerals
9	Au_ppm_AA25	ALS Minerals
10	Au_ppm_AA24	ALS Minerals
11	Au_ppm_AA23	ALS Minerals
12	Au_ppm_PyroSAA	Bourlamaque ⁽¹⁾
13	Au_gpt_FA550	Bureau Veritas
14	Au_ppm_FA450	Bureau Veritas
15	Au_ppm_FA430	Bureau Veritas
16	Au_ppm_FAGRAV	Intertek - Chimitec ⁽¹⁾
17	Au_ppm_FAGEO	LabExpert ⁽¹⁾
18	Au_gpt_FAGr	Intertek - Chimitec ⁽¹⁾
19	Au_ppm_FA	Intertek - Chimitec ⁽¹⁾
20	Au_gpt_PYROGRAV	Bourlamaque ⁽¹⁾
21	Au_ppm_FA30	Intertek - Chimitec ⁽¹⁾
22	Au_ppm_FA50	Intertek - Chimitec ⁽¹⁾

Notes:

⁽¹⁾ Laboratory used for historical analyses.



11.2 Conclusion

The QP reviewed the sample preparation, analytical and security procedures, as well as insertion rates and the performance of blanks, CRM and check assays for the Osisko drill holes and concluded that the observed failure rates are within expected ranges, adequate follow-up was applied for failures, and that no significant assay biases are present. According to the QP's opinion, the procedure and the quality of the data are adequate to industry standards and the resulting database is suitable for the purpose of the Mineral Resource Estimate.



12. Data Verification

The Mineral Resource Estimate (“MRE”) in this report is based on drill data from several eras of drilling at the Windfall Project that include the historical holes completed between 1977 and 2015, and the current Osisko programs since 2015.

The overall database close-out date for the resource estimates is June 7, 2022.

The Project database contains 4,834 drill holes for 1,852,861 metres of core in the Mineral Resource Estimate area.

For the purpose of the 2022 MRE, the QP performed a basic verification on the entire Project database and checked new holes since the last MRE.

12.1 Site Visits

Pierre-Luc Richard, P. Geo., visited the Windfall Project on January 28 and 29, 2021, as well as on January 22 and 23, 2022, and on July 22 and 23, 2022. The purpose of the visits was to review the Windfall Project with the Osisko team.

The 2021-2022 site visits included visual inspections of core, a tour of the core storage facility, underground visits, a survey of numerous drill hole casings in the field, and discussions with geologists from Osisko (Figure 12-1 to Figure 12-5). The QP was also able to see drills in action on site during some of the site visits (Figure 12-2).

A review of assaying, QA/QC and drill hole procedures, downhole survey methodologies, and descriptions of lithologies, alterations and structures were also completed during the site visits (Figure 12-3 and Figure 12-4).

12.2 Sample Preparation, Analytical, QA/QC and Security Procedures

Osisko procedures are described in Chapters 10 and 11 of the current report. Discussions held with on-site geologists allowed to confirm said procedures were adequately applied.

The QP reviewed several sections of mineralized core while visiting the Project. All core boxes were labelled and properly stored. Sample tags were present in the boxes, and it was possible to validate sample numbers and confirm the presence of mineralization in witness half-core samples from the mineralized zones (Figure 12-4).

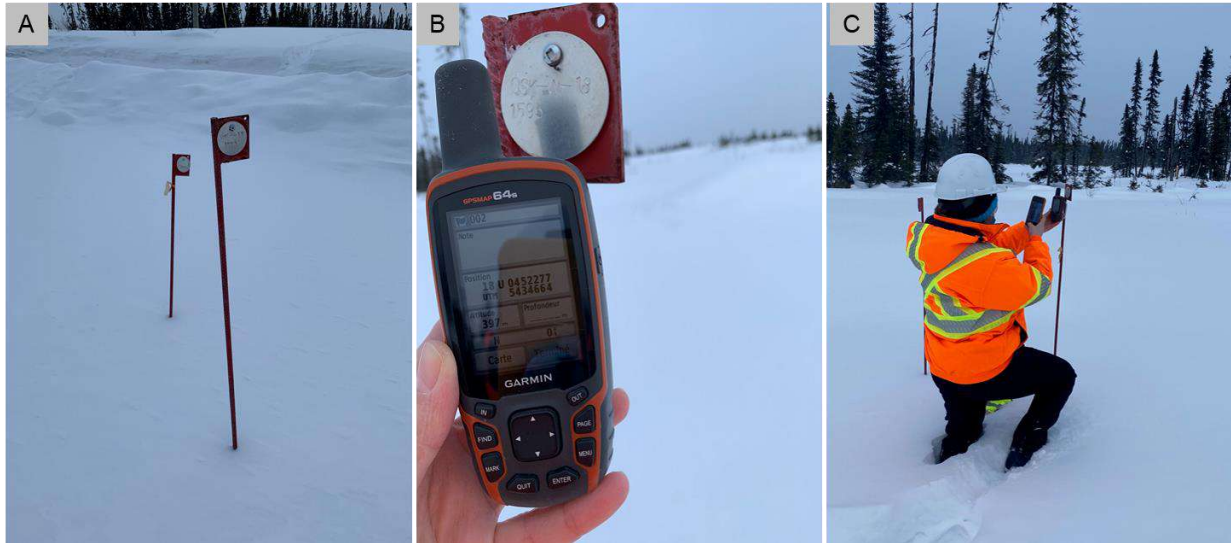

Figure 12-1: Drill collar review during a QP site visit



Figure 12-2: Visit of an active drill on site during a QP site visit



Figure 12-3: A) and B) Sample preparation room; C) and D) Samples ready for shipment to the laboratory



Figure 12-4: A) and B) Core review in the core logging facility, with C) Sample tags; and D) Identification tags

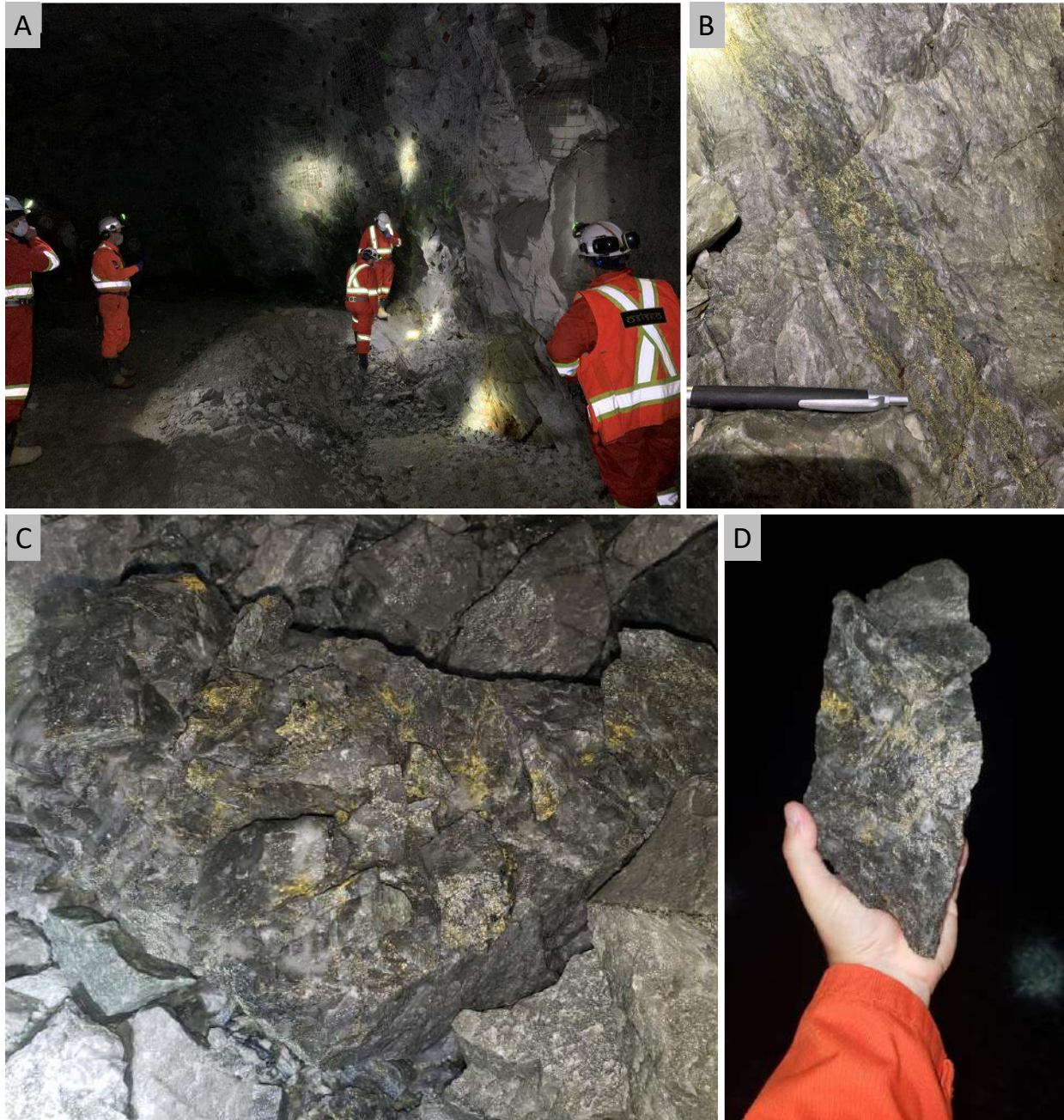

Figure 12-5: A) Underground visit; B) Observed mineralization; C) and D) Multiple examples of visible gold in muck samples from the Lynx Bulk sample area



12.3 Drill Hole Database

12.3.1 Drill Hole Location

For drilling conducted since the previous MRE, all drill collars have been surveyed by Osisko Mining using a LEICA high-definition GPS. This internal surveying process for all surface and underground drill holes is regularly validated by external consulting surveyors.

Random field checks with hand held GPSMAP 64S were conducted for several drill holes during one of the site visits (Figure 12-1). The differences between the database location and the recorded measurement are within the order of precision of the handheld GPS (+/- 3 m).

12.3.2 Downhole Survey

Spurious measurements were tagged by Osisko geologists in the database and were not considered by the software for the modelling.

Consistency of the whole downhole survey table was checked by the QP by visually looking for unrealistic pathways and with automatic check of large variation of dip or azimuth in Excel.

12.3.3 Assays

The QP was granted access to the original assay certificates directly from the laboratories for all holes drilled by Osisko since the last MRE on the Project. The assays recorded in the database were compared to the original certificates from the different laboratories and no discrepancies were detected.

As explained in Chapter 11 of the herein report, the final Au result in the assay table, recorded as "Au_FINAL", is based on two levels of ranking, including QA/QC status and analysis method. The "Au_FINAL" field is selected with an automated procedure that follows very precise rules and is executed daily. The value recorded as "Au_FINAL" always corresponds to the Au value obtained by fire assay fusion and metallic screen method, when available, followed by fire assay fusion with gravimetric finish result, when available. If none of these results are available, the fire assay fusion with atomic absorption spectroscopy ("AAS") finish is selected for the "Au_FINAL" value.

The lower detection limits were set to half the detection limit.

This rule has also been applied with historical assays data.



12.4 Conclusion

The QP is of the opinion that the drilling, sampling and assaying protocols in place are adequate. The database for the Windfall Project is of good overall quality. In the QP's opinion, the Project database has been adequately validated and is suitable for use in the estimation of mineral resources.



13. Mineral Processing and Metallurgical Testing

13.1 Introduction

The following chapter presents metallurgical testwork results for work conducted on the Windfall deposit as well as results from the following previously published reports:

- “Mineral Resource Estimate Update for the Windfall Project, located in Eeyou Istchee James Bay, Québec, Canada” by BBA (Richard and Bélisle, 2022) (“MRE 2022”);
- “Mineral Resource Estimate Update for the Windfall Project, located in Eeyou Istchee James Bay, Québec, Canada” by BBA (Richard et al., 2021) (“MRE 2021”);
- “NI 43-101 Technical Report Preliminary Economic Assessment of the Windfall Project, Lebel-sur-Quévillon, Québec” by BBA (Hardie et al., 2021) (“PEA 2021”).

The most recent metallurgical test program for the Windfall Project is ongoing since the PEA 2021. The testwork program is performed under the supervision of Osisko, in collaboration with BBA. The metallurgical test plan aims to determine an optimal flowsheet and generate engineering data for average mineralized material feed grades. The metallurgical test plan included composite samples from six zones: Zone 27, Caribou, Main Lynx, Lynx 4, Triple Lynx and Underdog.

SGS laboratories in Québec City and Lakefield provide most of the metallurgical services required.

Former metallurgical testwork results for work conducted on the Windfall deposit can be found in the previously published reports:

- “NI 43-101 Technical Report Preliminary Economic Assessment of the Windfall Lake Project, Lebel-sur-Quévillon, Québec” by BBA (Hardie et al., 2018) (“PEA 2018”);
- “An Updated Mineral Resource Estimate for the Windfall Lake Project, Located in the Abitibi Greenstone Belt, Urban Township, Eeyou Istchee James Bay” by Micon International Ltd. (Murahwi and Torrealba, 2020) (“MRE 2020”).

13.2 Windfall Historical Testwork

The following sections presents a summary of the most recent testwork described from the BBA 2022 MRE, BBA 2021 MRE and BBA PEA 2021 reports.



13.2.1 PEA (2021) Mineralogical Study

TESCAN Integrated Mineral Analyzer (“TIMA”) and Quantitative Evaluation of Materials (“QEM”) for gold were conducted by SGS (Fleury-Frenette and Grammatikopoulos, 2021) on one composite from Underdog zone. The composites head assay was 6.56 Au g/t. Gold minerals identified occur mainly as pyrite (18%), including quartz/feldspar (9%) and complex (5%). In terms of exposure, 71.3% of the gold is exposed, 26.1% is liberated and 2.6% is locked. By frequency, 84% of gold minerals occur as fine grains (<5 µm), which account for only 19% of the total gold (by mass). The main findings for the visible microscopic gold mineral grains (≥0.5 µm) are summarized in Table 13-1.

Mineralogical results for other zones can be found in Chapter 13 of the PEA 2021 report.

Table 13-1: Characteristics of microscopic gold for Underdog sample

Sample ID	Au-Mineral abundance	Size range ECD ⁽¹⁾ (µm)	Average ECD (µm)	Main minerals associated with exposed and locked Au-minerals
Underdog Comp	Gold (89%), electrum (8%), and non-identified Bi-Minerals (Au/Ag) (3%)	0.6-30.6	3.5	Pyrite 18%, quartz/feldspars 9%, complex 5%.

⁽¹⁾ ECD: Equivalent Circular Diameter.

13.2.2 MRE (2021) and PEA (2021) Comminution Testwork

For the MRE 2021, comminution testwork on waste, Zone 27, Caribou, Lynx and Underdog composites was performed at SGS including SMC, RWi, BWi and Ai. For Zones 27 and Caribou, Axb is harder than the values obtained during the PEA 2018 testwork campaign. For the waste, it is softer than the previous values but only one sample was tested.

During the PEA 2021, a total of 68 samples, comprising 40 samples considered as mineralized material and 28 samples as waste, were submitted for comminution testwork at SGS in various phases of testing. This testwork was completed by SGS at Lakefield (Samne, 2018 & 2019; Verret, 2018; Zhou and Downing, 2017 & 2018 – Report 16159-001) and Vancouver (Lascelles and Samne, 2022 – Report 16159-11).

The summary of the grindability test average results is presented in Table 13-2.

Additional comminution testwork on a composite of Lynx and Zone 27 was performed at SGS including SMC, BWi and MacPherson tests. The results are slightly softer than the ones observed in later tests. The results are presented in Table 13-3.



Table 13-2: Grindability test average results

Composite by zone / Statistics	Relative density			JP parameters				Work indices (kWh/t)						RWi / BWi	AI (g)	Assays (ppm, %)			
	CWi	DWT	SMC	Axb ⁽¹⁾	Axb ⁽²⁾	t _a ⁽¹⁾	SCSE	CWi	RWi	BWi @80M	BWi @170M	BWi @230M	BWi @270M			BWi @325M	Au	Si	S
PEA 2021 Overall average	2.79	2.80	2.84	26.2	29.6	0.38	12.1	18.4	16.3	13.1	12.3	13.5	11.5	14.1	1.25	0.199	4.19	27.8	3.93
PEA 2021 Overall 80 th percentile	2.74	2.74	2.77	21.1	25.8	0.28	12.7	22.1	18.8	14.7	14.6	16.3	11.5	15.8	1.34	0.282	8.18	30.5	7.43

(1) Axb and t_a from DWT (drop weight test).

(2) Axb from SMC (SAG mill comminution).

Table 13-3: Lynx and Zone 27 grindability test results

Composite	Specific Gravity ("SG")	SMC		BWi (kWh/t)	MacPherson Autogenous Grindability							
		Axb	t _a		Feed (kg/h)	Hardness percentile	F ₈₀ (µm)	P ₈₀ (µm)	Gross work index (kWh/t)	Correlated work index (kWh/t)	Hardness percentile	Gross specific energy input (kWh/t)
Bulk Mix Lynx-27	2.89	30.5	0.3	12.0	10.4	51	22,197	171	10.5	10.5	19	7.3



13.2.3 MRE (2021) and PEA (2021) Gravity Recovery Testwork

13.2.3.1 Extended Gravity Recoverable Gold (e-GRG)

Material from the 2019 Lynx bulk sample was submitted to e-GRG testing at SGS Lakefield. The tested GRG value was 66.9%, similar to the result obtained during the Lynx bulk sample.

An e-GRG test was also performed on a composite from Underdog zone leading to a GRG of 44.1%.

13.2.3.2 Bulk Gravity Testwork

Prior to the evaluation of the gold recovery in the leaching circuit, the Zone 27, Caribou and Lynx composites underwent a gravity pre-treatment. Only the gravity tailings were submitted to leaching testing. The bulk gravity results are presented in Table 13-4. The gold distribution in percentage varies from 1.2% to 20.0%.

Table 13-4: Bulk gravity reconciled results

Zone	Sample	Weight (kg)	P ₈₀ (µm)	Head grade calculated Au g/t	Falcon - Mozley Concentrate		
					Grade Au g/t	Distribution (%)	
						Weight	Au
Caribou	P3-A	20.2	110	8.36	333.9	0.05	1.83
Caribou	P3-B	27.8	105	9.18	378.8	0.03	1.19
Caribou	P3-C	17.3	100	6.17	795.0	0.05	6.2
Caribou	P3-D	12.3	99	11.62	2,460.0	0.05	9.65
Caribou	Caribou HP-LG	9.9	~150	3.23	247.0	0.1	6.8
Caribou	Caribou LP-LG	11.1	~150	3.46	289.0	0.1	6.7
Zone 27	P3-E	29.8	107	3.89	249.0	0.03	1.84
Zone 27	P3-F	8.7	132	10.36	650.0	0.10	6.09
Zone 27	P3-G	19.7	114	3.55	538.0	0.04	5.56
Zone 27	P3-H	17.8	96	8.63	4,165.0	0.03	16.6
Zone 27	HP-LG	11.1	~150	5.09	245.0	0.1	4.5
Zone 27	LP-LG	9.7	~150	2.85	109.0	0.1	4.3
Lynx	P3-I	21.4	101	4.71	277.0	0.04	2.22
Lynx	P3-J	22.3	115	11.54	859.0	0.04	2.95
Lynx	P3-K	21.4	103	6.31	1,396.3	0.04	8.15
Lynx	P3-L	20.7	103	10.32	1,518.2	0.05	7.26



Zone	Sample	Weight (kg)	P ₈₀ (µm)	Head grade calculated Au g/t	Falcon - Mozley Concentrate		
					Grade Au g/t	Distribution (%)	
						Weight	Au
Underdog	HP-HG	10.87	~150	6.35	1,448.0	0.06	13.39
Underdog	HP-MG	10.91	~150	6.93	679.0	0.12	11.99
Underdog	LP-LG	11.04	~150	3.21	227.0	0.11	7.46
Underdog	LP-MG	11.1	~150	7.19	1,605	0.09	19.97
Underdog	LP-HG	11.3	~150	10.22	1,903	0.05	10.22
Underdog	HP-LG	11.2	~150	2.54	70.0	0.08	2.28

Gravity recovery estimated by the simulations by FLS (Arnold, 2021) with 100% cyclone underflow was 30.9%, 40.9% and 36.3% gold recovery for Main, Lynx and Underdog respectively.

13.2.3.3 Gravity and Intensive Leach Testwork

A test has been performed on a composite from Lynx Bulk Sample to determine the recovery of the gravity concentrate to intensive leach. Each of the e-GRG concentrate pass has been leached using 0.05 g LeachAid¹, Hydrogen Peroxide to maintain a dissolved oxygen value higher than 20 ppm and 20.0 g/L cyanide for 24 hours. The gold and silver recoveries were very high, yielding values higher than 98.0% and 94.4% respectively. Results are presented in Table 13-5.

Table 13-5: Intensive leach results

e-GRG Pass #	Head Au (g/t)	Au recovery (%)	Head Ag (g/t)	Ag recovery (%)
1	1,249	98.5	508	97.9
2	1,127	99.2	489	96.7
3	602	98.0	300	94.4

¹ LeachAid is a product from GCA Consep Acacia used as a liquid oxygen and peroxide replacement in intensive leach reactors.



13.2.4 MRE (2021) and PEA (2021) Leaching Testwork

Following the PEA 2018, optimization testwork was performed to determine the optimal leaching parameters on the gravity tails. A total of 38 CIL optimization tests were carried out varying: pre-leaching parameters, with or without $\text{Pb}(\text{NO}_3)_2$ at different concentrations, leaching feed size, slurry density, leaching time, NaCN concentration and DO concentration. pH was maintained at approximately 10.5.

Table 13-6 presents the parameters considered as optimal following this optimization phase.

Table 13-6: MRE (2021) Optimized leaching parameters

Feed		Pre-leaching parameters				Leaching parameters				
K_{80} (μm)	Density (%)	Time (h)	DO (ppm)	pH	$\text{Pb}(\text{NO}_3)_2$ (g/t)	Time (h)	Temp ($^{\circ}\text{C}$)	Carbon (g/L)	DO (ppm)	pH
37	40	4	12-14	10.5	300	24	19	10	12-14	10.5

Subsequently, variability testwork was performed on gravity tails composites from different zones, gold head grade, depth, and spatial area. 23 tests were performed, results ranging from 80.8% to 97.2% Au recovery and 67.4% to 91.2% Ag recovery. The complete results can be found in the PEA 2021 report.

Further optimization testwork was performed to determine the optimum plant operating parameters for the mineralized material being processed on the gravity tails. A total of 20 CIL optimization tests were carried out with varying parameters: pre-leaching parameters, with or without $\text{Pb}(\text{NO}_3)_2$ at different concentrations; leaching feed size; slurry density; leaching time; NaCN concentration and DO concentration. The pH was maintained at approximately 10.5. Results ranged from 88.5% to 95.3% Au recovery and 71.9% to 84.8% Ag recovery. The results are presented in Table 13-7.



Table 13-7: Optimization leaching results

Zone	Sample Name	Objective	Density (%)	Residue P ₈₀ (µm)	Reagent consumption		Gold		Silver	
					NaCN (kg/t)	CaO (kg/t)	Calculated head (Au g/t)	Au Rec (%)	Calculated head (Ag g/t)	Ag Rec (%)
Lynx	e-GRG Gravity Tails	Effect of grind size on kinetics	40	32	0.45	1.53	4.50	94.9	6.6	84.8
Lynx	e-GRG Gravity Tails	Effect of grind size on kinetics	40	42	0.34	1.39	5.19	93.6	5.0	71.9
Lynx	e-GRG Gravity Tails	Effect of grind size on kinetics	40	50	0.29	1.19	5.31	94.0	6.8	83.9
Lynx	e-GRG Gravity Tails	Effect of 50% solids on reagent consumption	50	34	0.19	1.62	5.15	94.3	6.4	80.0
Caribou	P3-B-Gravity Tails	Effect of 50% solids on reagent consumption	50	46	0.34	1.30	8.05	92.3	9.0	79.9
Caribou	P3-B-Gravity Tails	Effect of 50% solids on reagent consumption	40	43	0.63	2.56	7.20	90.9	8.7	77.3
Zone 27	P3-F-Gravity Tails	Effect of 50% solids on reagent consumption	50	44	0.28	1.71	8.79	89.5	9.7	74.8
Zone 27	P3-F-Gravity Tails	Effect of 50% solids on reagent consumption	40	48	0.39	1.73	8.91	90.1	136	81.0
Lynx	P3-K-Gravity Tails	Effect of 50% solids on reagent consumption	50	38	0.24	1.70	4.64	88.5	3.8	73.6
Lynx	P3-J-Gravity Tails	Effect of 50% solids on reagent consumption	40	44	0.22	1.90	9.87	89.6	11.1	78.9
Lynx	P3-J-Gravity Tails	Effect of 50% solids on reagent consumption	50	43	0.24	1.73	10.19	89.7	11.4	78.4
Lynx	e-GRG Gravity Tails	No pre-leach, with lead nitrate, DO 7-8 with air	50	37	0.43	1.25	4.44	94.1	6.5	81.6
Lynx	e-GRG Gravity Tails	No pre-leach, with lead nitrate, DO 12-15 with O ₂	50	37	0.50	1.17	5.08	94.9	6.8	83.8
Lynx	e-GRG Gravity Tails	No pre-leach, no lead nitrate, DO 7-8 with air	50	36	0.63	0.94	5.05	95.3	7.2	82.0
Lynx	e-GRG Gravity Tails	No pre-leach, no lead nitrate, DO 12-15 with O ₂	50	36	0.53	0.95	4.86	94.7	6.8	80.9



Zone	Sample Name	Objective	Density (%)	Residue P ₈₀ (µm)	Reagent consumption		Gold		Silver	
					NaCN (kg/t)	CaO (kg/t)	Calculated head (Au g/t)	Au Rec (%)	Calculated head (Ag g/t)	Ag Rec (%)
Mix Lynx - Zone27 - Caribou	G1 Gravity Tails	No pre-leach, with lead nitrate, DO 7-8 with air	50	41	0.44	1.30	6.17	91.7	6.2	78.8
Mix Lynx - Zone27 - Caribou	G1 Gravity Tails	No pre-leach, with lead nitrate, DO 12-15 with O ₂	50	43	0.48	0.88	5.72	91.4	5.8	76.9
Mix Lynx - Zone27 - Caribou	G1 Gravity Tails	No pre-leach, no lead nitrate, DO 7-8 with air	50	40	0.56	1.17	4.89	90.4	5.3	78.5
Mix Lynx - Zone27 - Caribou	G1 Gravity Tails	No pre-leach, no lead nitrate, DO 12-15 with O ₂	50	40	0.41	1.15	5.14	91.4	5.3	76.1
Mix Lynx - Zone27 - Caribou	Comp P3 OPT	No pre-leach, no lead nitrate, DO 12-15 with O ₂	50	37	0.64	1.50	6.31	91.4	6.8	74.0



13.2.5 MRE (2021) Detoxification Testwork

The SO₂/AIR process was investigated at Cyanco's lab in Sparks, Nevada (Cyanco Corporation, 2019). The sample, a mix of Lynx, Main, Underdog and Osborne zones derived from the leach variability testwork was sent from SGS to Cyanco where it has been split in two: "Sample with GoldiLOX²" and "Sample Without GoldiLOX". Leach testwork showed GoldiLOX led to an increase in gold recovery and detox was then performed to validate its impact on the detox process itself.

Testwork showed 2 hours of retention time are required and the two targets, below 10 and 5 CN_{WAD} could be met for all samples at 40% or 45% solids. SO₂ addition ranged from 4.0 to 6.0 (g/g CN_{WAD}) and Ca(OH)₂ addition ranged from 2.1 to 3.5 (g/gCN_{WAD}). Cu²⁺ as catalyzer is not required.

13.3 Windfall Recent Testwork

The following sections present a summary of the testwork performed since the PEA 2018, MRE 2020, MRE 2021 and MRE 2022 reports.

The testwork program was performed under the supervision of BBA in collaboration with Osisko. The metallurgical test plan aimed to collect further metallurgical information. The metallurgical test plan included composite samples from three zones and lithology: Triple Lynx zone, Lynx 4 zone and Gabbro lithology.

SGS laboratories in Québec City and Lakefield provided most of the metallurgical services required (Lascelles and Samne, 2022).

13.3.1 Sample Selection and Compositing

Composites samples were prepared from NQ drill hole intervals located within the mineral resource envelope for metallurgical testing. A total of 328 intervals totalling 264 m of core from 169 different drill holes were selected to prepare composites, each having a sufficient quantity of material to complete the proposed metallurgical testwork.

Recent testwork hole locations are illustrated in Figure 13-1 and Figure 13-2 while hole locations for all samples are illustrated in Figure 13-3 and Figure 13-4.

² GoldiLOX is a product from Gekko. It is an advanced leach accelerant that can increase gold recovery while shortening intensive cyanidation times, making gold production a faster and more effective process.

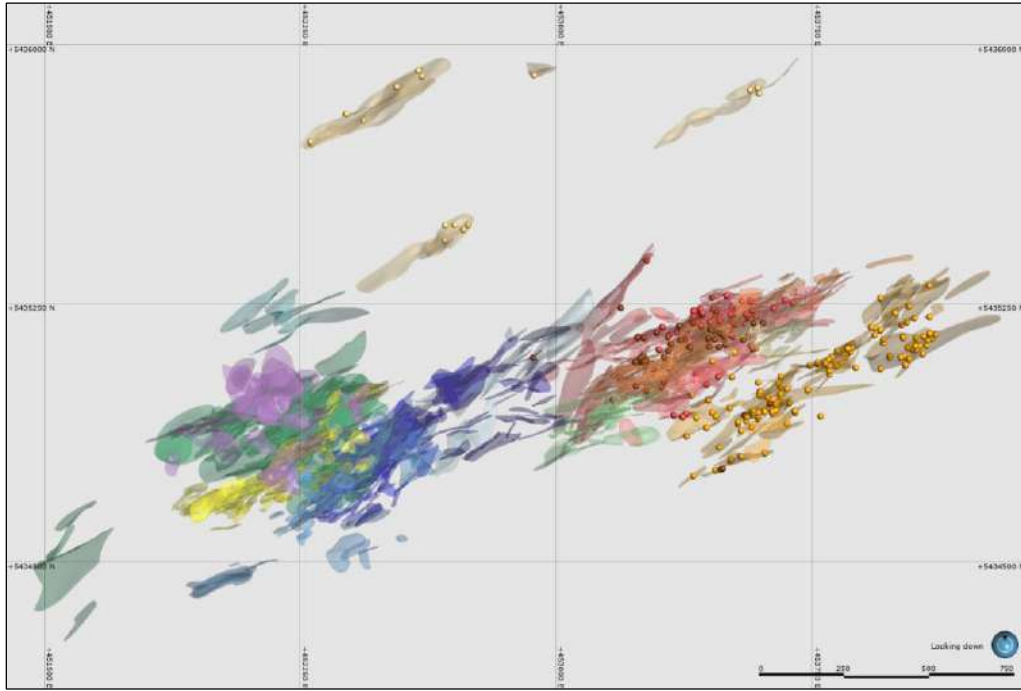

Figure 13-1: Plan view of the recent testwork sample hole locations

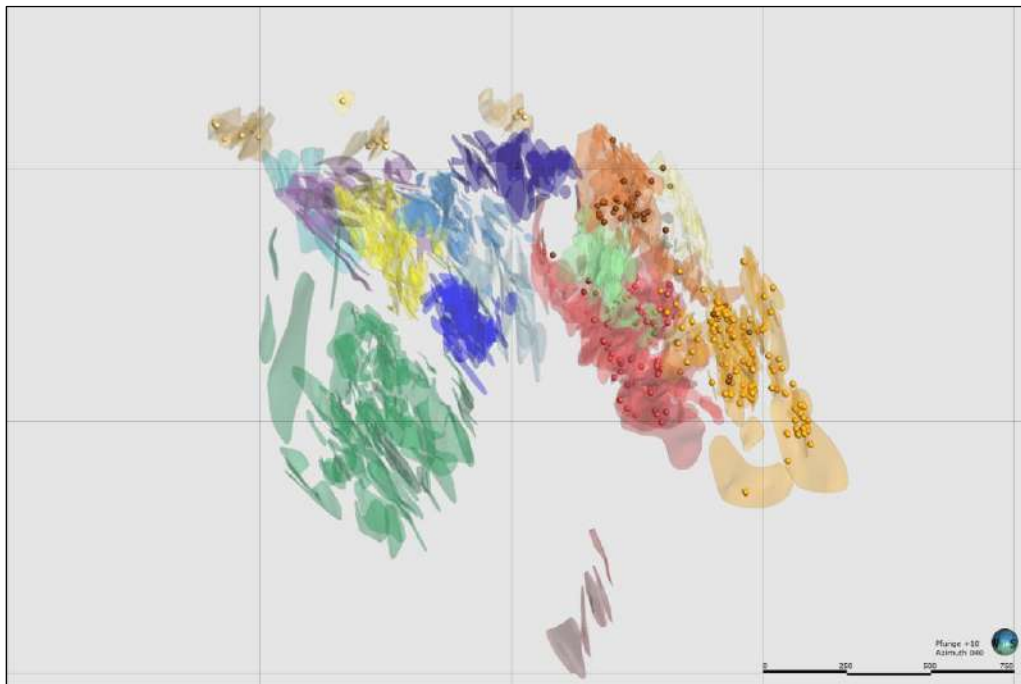

Figure 13-2: View looking N040 of the recent testwork sample hole locations

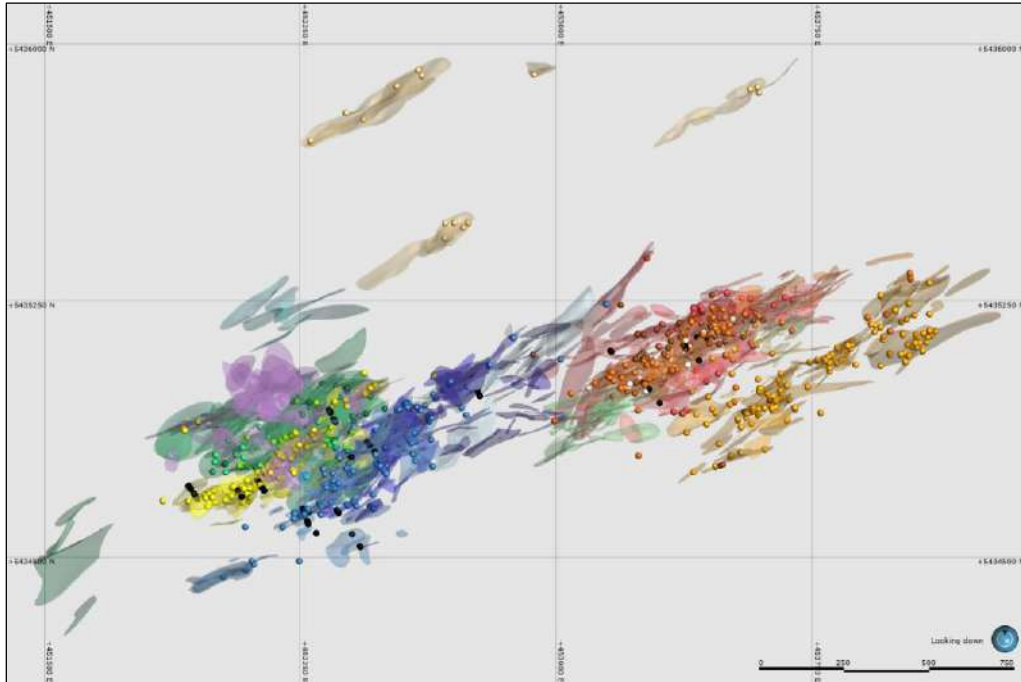

Figure 13-3: Plan view of all sample hole locations

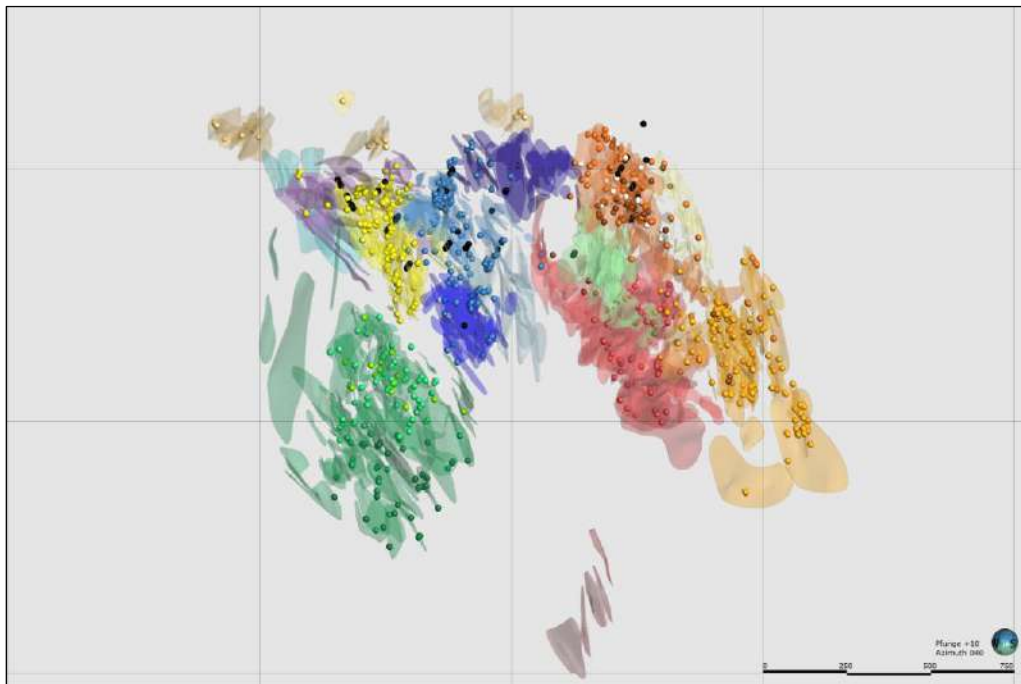

Figure 13-4: View looking N040 of all sample hole locations



13.3.2 Mineralogical Study

QEMSCAN for gold were conducted by SGS on three different composites from Triple Lynx zone, Lynx 4 zone and Gabbro lithology. The head assays of the composites were 6.23 Au g/t, 8.90 Au g/t and 4.97 Au g/t, respectively.

The main gold mineral identified in the Triple Lynx and Lynx 4 composites is native gold with the following chemistry: Triple Lynx Au 82.4% and Lynx 4 Au 82.4%.

For all three composites, by frequency, more than 75% of gold minerals occur as fine grains ($\leq 15 \mu\text{m}$). Gold grains are mainly associated with pyrite. The main findings for the visible microscopic gold mineral grains ($\geq 0.5 \mu\text{m}$) are summarized in Table 13-8.

Table 13-8: Characteristics of microscopic gold for Triple Lynx, Lynx 4 and Gabbro sample

Sample ID	Au-Mineral abundance	Size range ECD (μm)	Average ECD (μm)	Main minerals associated with exposed and locked Au-minerals
Triple Lynx	Gold (92.5%), Electrum (6.4%), Petzite (0.4%), Aurostibite (0.3%), Au-Dyscrasite (0.2%), Others (0.2%)	0.6-62.5	6.2	Pyrite (82.1%), Silicates/Pyrite (4.8%), Arsenopyrite (2.2%)
Lynx 4	Gold (75.5%), Electrum (8.6%), Petzite (4.34%), Au-Ag-Te (4.22%), Au-Ag-Pb-Te (3.65%), Calaverite (3.14%), Au-Sb (0.16%), Others (0.43%)	0.6-45.5	5.5	Pyrite (67.1%), Dolomite (16.5%), Silicates (10.2%), Altaite/Silicates (2.25%)
G3-Tail (Gabbro)	Gold (94%), Electrum (3%) and Petzite (3%)	0.6-49.2	4.7	Pyrite (26%), Complex (16%)

13.3.3 Comminution Testwork

During the recent study, comminution testwork on Triple Lynx zone, Lynx 4 zone and from Gabbro lithology composites was performed at SGS including SMC, RWi, BWi and Ai. The samples are slightly softer than the ones from the other zones.

The summary of the grindability tests is presented in Table 13-9.



Table 13-9: Comminution test results per zone for recent testwork

Composite by zone ³	No. samples tested	SG	SMC		RWi (kWh/t)	Bwi (kWh/t)	Ai (g)
			Axb	t _a			
Triple Lynx	4	2.79	32.0	0.29	14.3	11.5	0.22
Lynx 4	7	2.82	33.5	0.31	14.2	11.4	0.18
Gabbro	4	2.89	28.7	0.25	-	12.4	0.16

13.3.4 Gravity Testwork

13.3.4.1 Extended Gravity Recoverable Gold (e-GRG)

Composites from Triple Lynx zone, Lynx 4 zone and from Gabbro lithology were submitted to e-GRG testing at SGS Lakefield. The tested GRG value ranged from 38.3% to 50.0%, similar to the historical testwork values which ranged from 25.0% to 66.9%. The results are summarized in Table 13-10.

Table 13-10: e-GRG recent testwork results

Sample	As tested Grade (g/t)	As tested GRG (%)
Triple Lynx	5.6	40.9
Lynx 4	8.4	38.3
Gabbro	8.6	50.0
Underdog	7.2	44.1

Further testwork was completed to determine variability within Triple Lynx and Lynx 4 GRG values. The head grade does not seem to affect the GRG and generally results vary by +-5%. The Lynx 4 sample with 8.3 Au g/t appears to be an outlier. Triple Lynx tested GRG appears to be significantly higher (about 10%) than previously tested. The results are summarized in Table 13-12.

³ Gabbro composites represents a lithology in this case.



Table 13-11: e-GRG variability testwork results

Sample	As tested Grade (g/t)	As tested GRG (%)
Lynx 4	44.9	38.4
Lynx 4	12.3	40.2
Lynx 4	8.3	31
Triple Lynx	43.5	50.8
Triple Lynx	11.6	46.4
Triple Lynx	8.6	52.8

13.3.4.2 Bulk Gravity Testwork

Prior to the evaluation of the gold recovery in the leaching circuit, the Triple Lynx zone, Lynx 4 zone, and Gabbro lithology composites underwent a gravity pre-treatment. Only the gravity tailings were sent for leaching testing. The bulk gravity results are presented in Table 13-12. The gold distribution in percentage varies from 5.5% to 25.5%.

Table 13-12: Bulk gravity reconciled results of recent testwork

Composite by zone ⁽¹⁾	Sample	Weight (kg)	P ₈₀ (µm)	Head grade calculated Au g/t	Knelson-Mozley Concentrate		
					Grade Au g/t	Distribution (%)	
						Weight	Au
Triple Lynx	LG	4.48	119.2	3.91	122	0.65	20.23
Triple Lynx	MG	11.12	151.3	6.42	632	0.19	18.34
Triple Lynx	HG	6.08	159.1	9.06	601	0.28	18.51
Lynx 4	LP-LG	6.08	141.4	3.43	76.1	0.42	9.22
Lynx 4	LP-MG	10.14	146.6	4.88	133	0.20	5.47
Lynx 4	LP-HG	9.12	135.7	11.08	672	0.19	11.30
Lynx 4	HP-LG	6.76	128.6	3.67	199	0.20	15.76
Lynx 4	HP-MG	11.69	148.9	8.40	1,318	0.11	17.23
Lynx 4	HP-HG	5.07	145.4	17.36	1,048	0.42	25.45
Gabbro	LG	3.23	67.6	3.98	145	0.41	15.16
Gabbro	MG	9.19	55.4	5.96	612	0.14	14.85
Gabbro	HG	6.3	69.8	8.87	582	0.17	10.85

⁽¹⁾ Gabbro composites represents a lithology in this case.



13.3.4.3 Gravity Circuit Modelling

Extended gravity recoverable gold results were sent to FLSmidth for modelling purposes. The gravity recovery results at the mill discharge for each sample are presented in Table 13-13 (Arnold, 2022).

Table 13-13: Gravity recovery at the mill discharge for each sample

Ore	Feed Rate to Gravity (tph)	Circ. Load Treated (%)	Gravity Recovery (%)
Caribou	580	92	24
27	580	92	39
Lynx	580	92	36
Triple LYNX	580	92	29
LYNX 4	580	92	26
Underdog	580	92	37
Main Lynx (2)	580	92	38
LX4-MG	580	92	23
LX4-HG	580	92	29
TLX-MG	580	92	37
TLX-HG	580	92	34

High-grade samples (TLX-50, LX4-50 and Bulk Lynx) are not included since the tested gold grade was not representative of operation conditions. For gold recovery purposes, the gravity recovery used is an average per zone.

13.3.5 Leaching Testwork

Using the previously optimized parameters, leaching testwork was performed on Triple Lynx and Lynx 4 zones. For Triple Lynx, tested grades varied between 2.95 g/t and 7.49 g/t with gold recoveries ranging from 77.9% to 92.4%. For Lynx 4, tested grades varied between 3.20 g/t and 13.02 g/t with gold recoveries ranging from 76.7% to 90.9%. Some tests were repeated with a smaller grinding size of approximately 20 µm. Gold recovery significantly improved for testwork conducted with smaller particles due to increased liberation. The increase in gold recovery averages 6%.



Table 13-14: Leaching testwork for Triple Lynx and Lynx 4

Zone	Sample Name	Residue P ₈₀ (µm)	Reagent consumption		Gold		Silver	
			NaCN (kg/t)	CaO (kg/t)	Calculated head (Au g/t)	Au Rec (%)	Calculated head (Ag g/t)	Ag Rec (%)
Triple Lynx	Triple Lynx LG	42	0.50	2.98	3.17	77.9	1.29	79.0
Triple Lynx	Triple Lynx LG	20	0.37	3.19	2.95	84.4	1.81	71.0
Triple Lynx	Triple Lynx MG	41	0.53	2.73	5.62	86.6	2.18	87.5
Triple Lynx	Triple Lynx MG	28	0.69	4.83	5.65	83.9	2.66	76.6
Triple Lynx	Triple Lynx MG	21	0.61	2.88	5.68	89.3	2.69	80.5
Triple Lynx	Triple Lynx HG	42	0.40	3.08	7.49	92.4	3.52	88.0
Lynx 4	Lynx 4 LP-LG	41	0.42	2.83	3.38	76.7	5.16	80.5
Lynx 4	Lynx 4 LP-LG	20	0.36	3.47	3.20	88.4	5.25	82.3
Lynx 4	Lynx 4 LP-MG	40	0.66	1.99	5.14	86.8	6.14	81.7
Lynx 4	Lynx 4 LP-HG	43	0.70	2.20	9.81	85.1	10.79	88.8
Lynx 4	Lynx 4 LP-HG	26	0.93	5.75	10.18	88.2	12.24	91.6
Lynx 4	Lynx 4 LP-HG	19	0.77	3.43	10.09	90.9	11.61	92.9
Lynx 4	Lynx 4 HP-LG	37	0.69	1.94	3.29	84.5	2.37	56.9
Lynx 4	Lynx 4 HP-MG	36	0.59	2.35	7.41	90.8	6.28	82.4
Lynx 4	Lynx 4 HP-HG	38	0.72	2.26	13.02	89.8	7.10	84.2

Considering the increased gold recovery acquired by diminishing grinding size in the previously mentioned testwork, further experiments were conducted on zones selected for recovery calculations. By grinding to a finer size, recovery improved by 3.5% for Lynx 4, 3.2% for Triple Lynx, 2.9% for Underdog, 1.3% for Lynx and 4.5% for Main. Lime consumption was higher for the finer particles, but cyanide consumption was equivalent or lower.



Table 13-15: Leaching testwork to determine grinding size effect on zones selected for recovery calculations

Zone	Sample Name	Residue P ₈₀ (µm)	Reagent consumption		Gold		Silver	
			NaCN (kg/t)	CaO (kg/t)	Calculated head (Au g/t)	Au Rec (%)	Calculated head (Ag g/t)	Ag Rec (%)
Lynx 4	Lynx 4 B	33	0.64	1.60	6.62	89.4	9.36	90.4
Lynx 4	Lynx 4 B	22	0.62	1.75	7.06	92.9	10.05	94.0
Triple Lynx	Triple Lynx B	32	0.66	1.41	5.46	90.8	3.10	83.4
Triple Lynx	Triple Lynx B	23	0.65	1.65	5.81	94.0	3.33	85.0
Underdog	Underdog B	36	0.86	1.70	6.34	93.2	3.37	85.1
Underdog	Underdog B	22	0.81	1.87	6.75	96.1	3.38	85.2
Lynx	Main Lynx B	35	0.77	2.17	9.34	95.1	12.53	88.0
Lynx	Main Lynx B	23	0.71	2.57	8.97	96.4	10.26	86.4
Main	Main Zone B	33	0.80	1.75	6.18	88.8	5.69	78.9
Main	Main Zone B	22	0.74	3.27	6.54	93.3	6.06	85.2

A leaching test was conducted on a representative composite to evaluate if the predicted recovery was similar to the experimental recovery. The tested recovery was 90.8%, while the calculated recovery was 91.6%, which is not a statistically significant difference (Table 13-16).

Table 13-16: Leaching testwork to compare a Main-Lynx-Lynx 4-Triple Lynx-Underdog composite direct recovery and its calculated recovery from the curves

Zone	Sample Name	Residue P ₈₀ (µm)	Reagent consumption		Gold		Silver	
			NaCN (kg/t)	CaO (kg/t)	Calculated head (Au g/t)	Au Rec (%)	Calculated head (Ag g/t)	Ag Rec (%)
Composite	Comp Blend	37	0.78	1.61	7.1	90.8	6.9	85.4

To verify Triple Lynx and Lynx 4 low-grade recoveries, additional tests were performed at 2.9 g/t and 4.4 g/t. Triple Lynx low-grade recovery was significantly higher than expected while Lynx 4 recovery was similar to the predicted recovery (Table 13-17). The average gold grade in those zones is in the high portion of the tested ranges, the low-grade recoveries should not have a significant impact on the overall Triple Lynx and Lynx 4 recovery .



Table 13-17: Leaching testwork to evaluate Triple Lynx and Lynx 4 low-grade recoveries

Zone	Sample Name	Residue P ₈₀ (µm)	Reagent consumption		Gold		Silver	
			NaCN (kg/t)	CaO (kg/t)	Calculated head (Au g/t)	Au Rec (%)	Calculated head (Ag g/t)	Ag Rec (%)
Triple Lynx	Comp TLX	37	0.29	1.23	2.91	91.7	--	--
Lynx 4	Comp LX4	37	0.27	1.20	4.36	84.6	--	--

13.3.6 Oxygen Demand

Oxygen demand testwork was conducted by SGS in 2022. Two composites were tested, representing respectively the first 5 years of the LOM and the next 5 years of the LOM. The main parameters and results of the testwork are summarized in Table 13-18. The composites showed an average oxygen uptake of 0.04 mg/L/min and 0.03 mg/L/min respectively, which is very low. Additional tests with different feed size, temperature and density will be requested to confirm whether these results are accurate.

Table 13-18: Oxygen Demand parameters and results

Sample	Objective	Residue P ₈₀ (µm)	Parameters								Oxygen uptake (mg/L/min)
			Feed (g)	Density (%)	Time (h)	DO (ppm)	pH	Temperature (°C)	PbNO ₃ (g/t)	NaCN (g/L)	
Years 1-5	Complete an oxygen uptake test	37	325	40	24	10-12	10.5-11	20	300	0.5	0.04
Years 5+	Complete an oxygen uptake test	37	325	40	24	10-12	10.5-11	20	300	0.5	0.03

13.3.7 Detoxification Testwork

New SO₂/Air process testwork was conducted by SGS in 2022. Two feed CN pulps were tested. The first one had a CNT of 200 mg/L, which decreased to <0.01 mg/L after a retention time of 1 hour. The second feed had a CNT of 137 mg/L, which decreased to 0.47 mg/L after a retention time of 1 hour. Both pulps ended up with <0.1 CN_{WAD}. The blends used represent respectively the first 5 years of the LOM and the next 5 years of the LOM.



13.4 Tailings Thickening, Filtration and Paste Production Testwork

Laboratory testwork was carried out by Pocock Industrial, Paterson & Cooke, Golder and Metso:Outotec. The purpose of the laboratory program was to provide information on dewatering, rheological and strength characteristics of the mill tailings to determine the most suitable paste backfill mix design to meet the underground mine requirements.

Pocock Industrial conducted thickening and filtration testwork on several products including flotation products and direct leaching product (P_{80} of 35.2 μm , solids SG of 2.87) generated during flowsheet development studies that took place for the Windfall Project.

Paste testwork from Paterson & Cooke was performed on two tailings leach residue samples having different particle size distributions (P_{80} of 37 and 20 μm).

Golder conducted paste testwork on two tailings leach residue samples having different particle size distributions (37 μm and 20 μm).

Metso:Outotec conducted thickening and filtration testwork on one sample (P_{80} of 43 μm) identified Lynx bulk tailings taken from the Lynx zone orebody at Osisko's Windfall property.

Osisko did perform the samples selection and preparation process.

13.4.1 Historical Testwork

13.4.1.1 Rheology Testwork at Pocock Industrial

Tests were performed to evaluate the rheological properties of the thickened slurries. Rheological testing was performed on thickener underflow slurry samples.

Data collected from the Fann viscometer provided information required to determine the maximum design underflow densities for a conventional and high-rate thickener. Data collected from the Haak viscometer provided information required to determine the maximum possible underflow densities for the ultra-high-rate thickener using industry accepted design criteria.

The static yield stress test results determined the minimum force required to initiate flow at various underflow densities (refer to Figure 13-5).

Correlations between apparent viscosity and shear rate, as shown in Figure 13-6, indicated that the material is classified as a non-Newtonian fluid and displays shear-thinning. Decrease in apparent velocity with increasing shear rate, as seen in Figure 13-6, shows the material to be in the pseudoplastics category of non-Newtonian fluids. Figure 13-7 shows the material shear stress versus shear rate results.

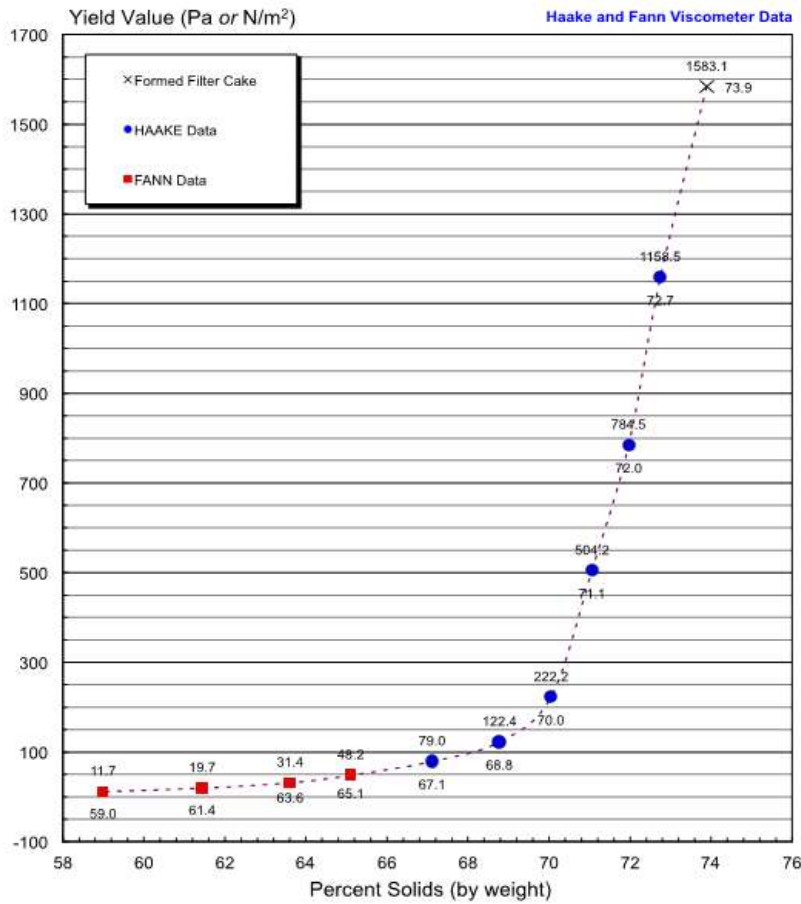

Figure 13-5: Yield stress vs. wt% solids

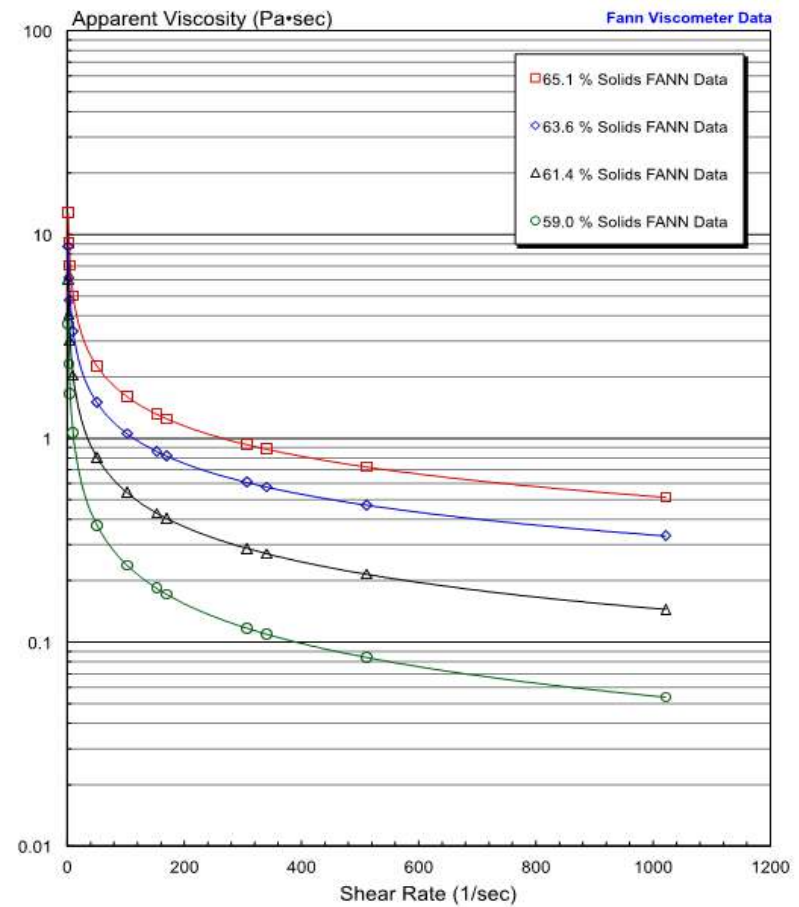

Figure 13-6: Apparent viscosity vs. shear rate

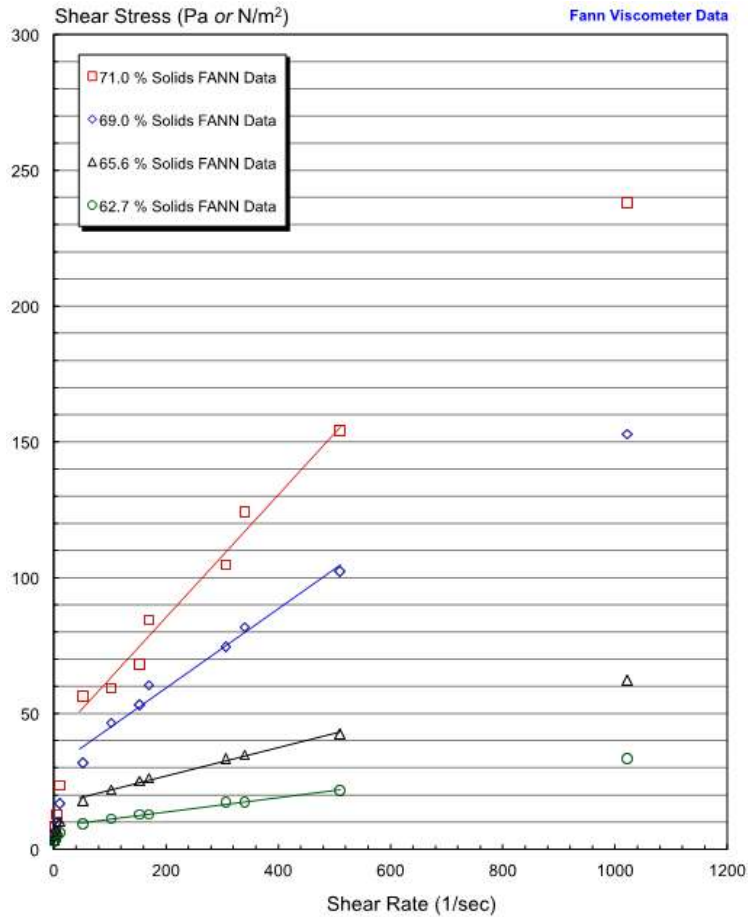

Figure 13-7: Shear stress vs. shear rate

13.4.1.2 Pressure Filtration at Pocock Industrial

Pressure filtration tests were performed to determine the effects of cake thickness and drying time on production rate and filter cake moisture.

The test summary for the two operational scenarios and selected design parameters are presented in Table 13-19. The cake moistures selected for design showed good discharge and stacking properties at reasonable dry times (3 minutes for air blow only, and 2.5 minutes for membrane squeeze with air blow). The results show that it is possible to achieve a %solid higher than 85%.



Table 13-19: Pressure filtration test results – Summary and design conditions

Material Type	Test Type	Feed Solids Conc. (%)	Dry Bulk Density (Mt/m ³)	Design Thickness	Sizing Basis (m ³ /Mt)	Design Cake Moisture (%)	Total Cycle Time (min)	Volumetric Production Rate Mtpd/m ³)	Area Basis Production Rate Mtpd/m ²)
Thickened combined P3-ML-CIL4-FEA Windfall (October 2018)	Air Blow Only	61.6	1,307	Chamber 60 mm / Cake 60 mm	0.956 (60 mm cake)	13.6	12.0	104.55	3.04
	Membrane Squeeze / Air Blow	61.6	1,412	Chamber 60 mm / Cake 56 mm	0.886 (56 mm cake)	13.1	12.0	112.93	2.95

13.4.1.3 Minerology and Chemical Analysis at Patterson & Cooke

Minerology was determined using X-Ray Diffraction ("XRD") and chemical whole rock analysis was performed on the samples using inductively coupled plasma ("ICP"). The ICP scan showed elevated levels of Si, Al, Fe, Ca, Mg and K, which indicates quartz, feldspar and pyrite minerology. Results are shown in Table 13-20 and Table 13-21.

Table 13-20: Chemical composition (wt%)

Compound	July 2020 Tailings	March 2021 Tailings
S	1.2	4.2
SiO ₂	72.5	64.1
Al ₂ O ₃	10.9	11.2
Fe ₂ O ₃	3.8	8.4
CaO	2.8	2.6
MgO	1.5	1.6
Na ₂ O	0.6	0.5
K ₂ O	2.4	2.6
TiO ₂	0.3	0.4
MnO	0.1	0.1
BaO	0.2	0.1
Total ICP	100.1	97.4
Loss On Ignition	5.1	5.6



Table 13-21: Mineralogical composition (phase wt%)

Mineral SQ-XRD	Chemical Composition	July 2020 Tailings	March 2021 Tailings
Quartz	SiO ₂	71.0	52.3
Muscovite	(H,K)AlSiO ₄	14.2	23.2
Ankerite	Ca(Mg _{0.67} Fe _{0.33} ²⁺)(CO ₃) ₂	10.1	7.8
Clinocllore	(Mg,Fe) ₆ (Si,Al) ₄ O ₁₀ (OH) ₈	2.9	4.6
Pyrite	FeS ₂	1.7	5.1

Decanted water from the samples were also subjected to chemical analysis to determine if they would be suitable for backfill use (refer to Table 13-22). No large presence of any heavy metals or problematic compounds were found during the analysis, therefore the water is considered suitable for backfill use.

Table 13-22: Decanted water chemical analysis (ppm)

Parameter	July 2020 Tailings	March 2021 Tailings
Sulfate	1,400	476
Sodium	400	187
Calcium	147	80
Chloride	32	21
Potassium	26	15
Magnesium	15	4

13.4.1.4 Rheology Testwork at Patterson & Cooke

Rheological testing was carried out. Cemented and uncemented tailings properties over a range of solids mass concentrations were compared. Results are shown in Figure 13-8.

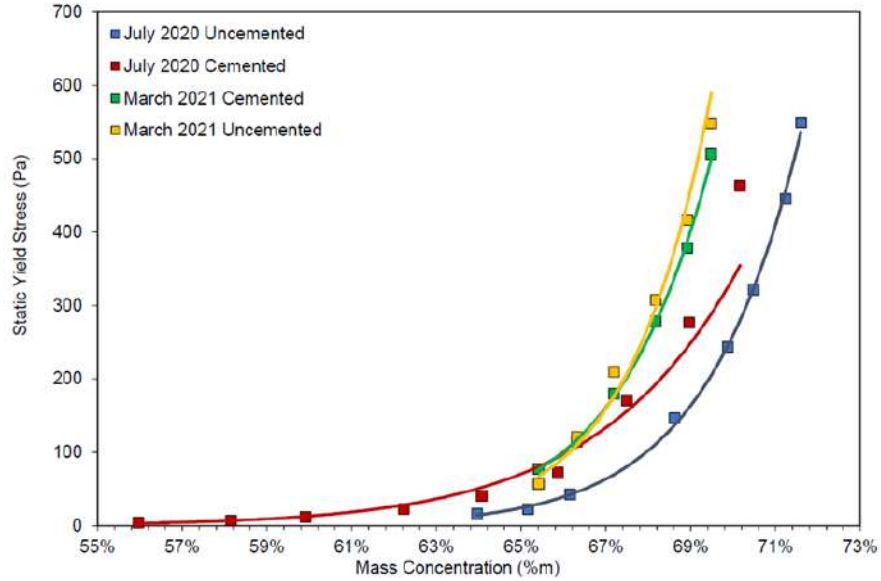

Figure 13-8: Static yield stress vs. mass concentration

The Boger slump height versus solids mass concentrations were also compared (Figure 13-9). A linear relationship between the slump and mass concentration was observed for both cemented and uncemented tailings.

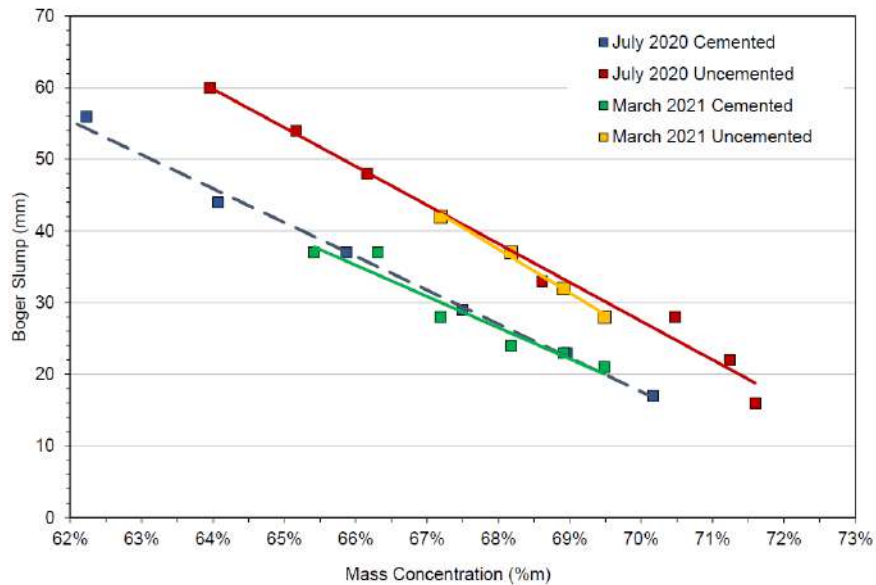

Figure 13-9: Boger slump vs. mass concentration



Cemented and uncemented samples were also subjected to the infinite bob and cup method. Samples rheograms are presented in Figure 13-10 to Figure 13-13. Figure 13-14 and Figure 13-15 show the Bingham yield stress and plastic viscosity relationships.

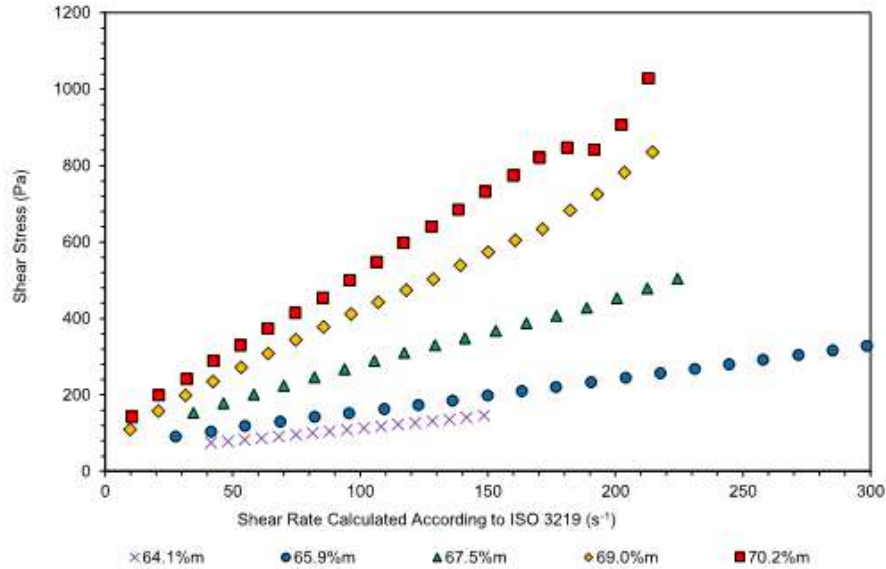

Figure 13-10: Cemented July 2020 tailings rheogram

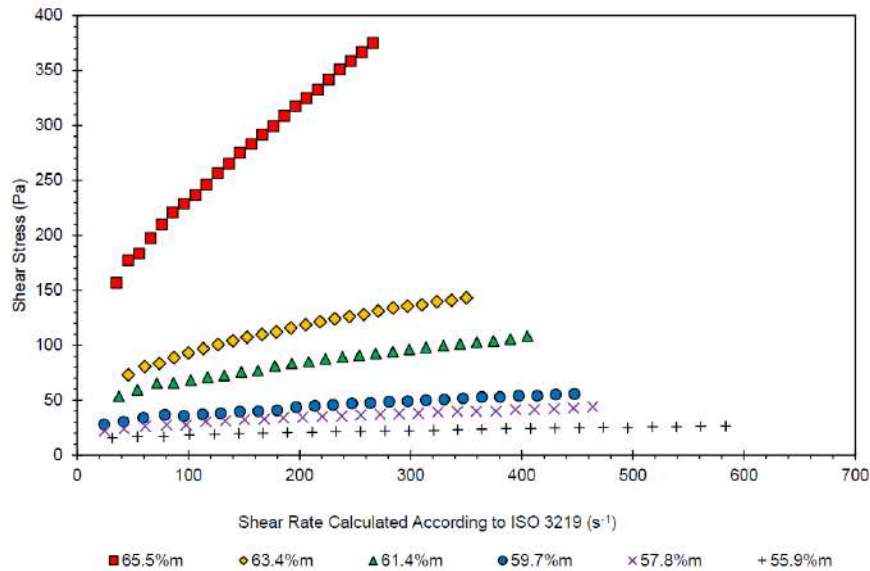

Figure 13-11: Cemented March 2021 tailings rheogram

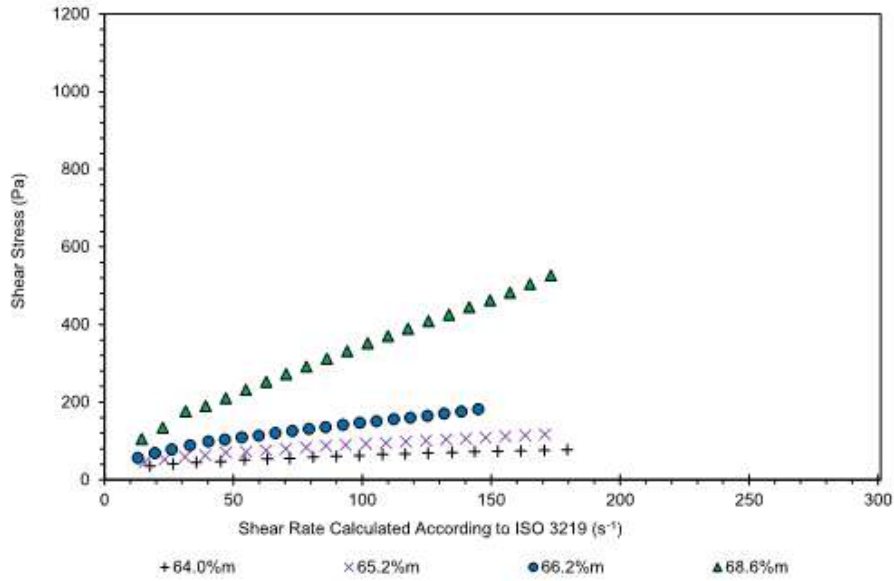

Figure 13-12: Uncemented July 2020 tailings rheogram

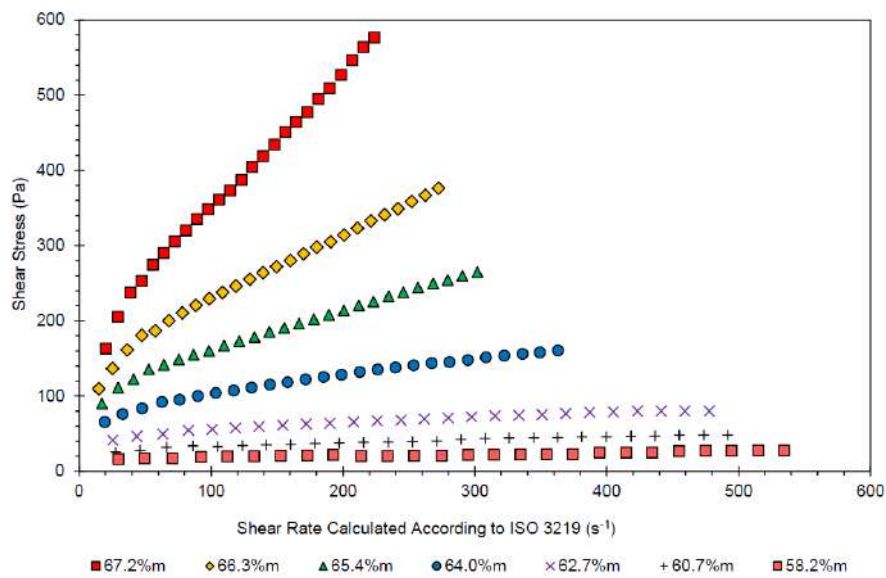

Figure 13-13: Uncemented March 2021 tailings rheogram

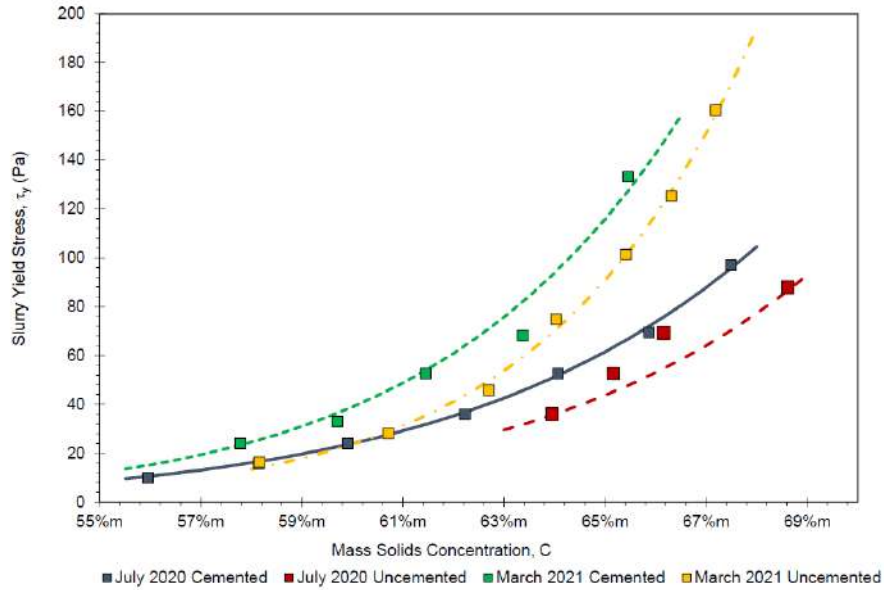

Figure 13-14: Bingham yield stress vs. mass solids concentration

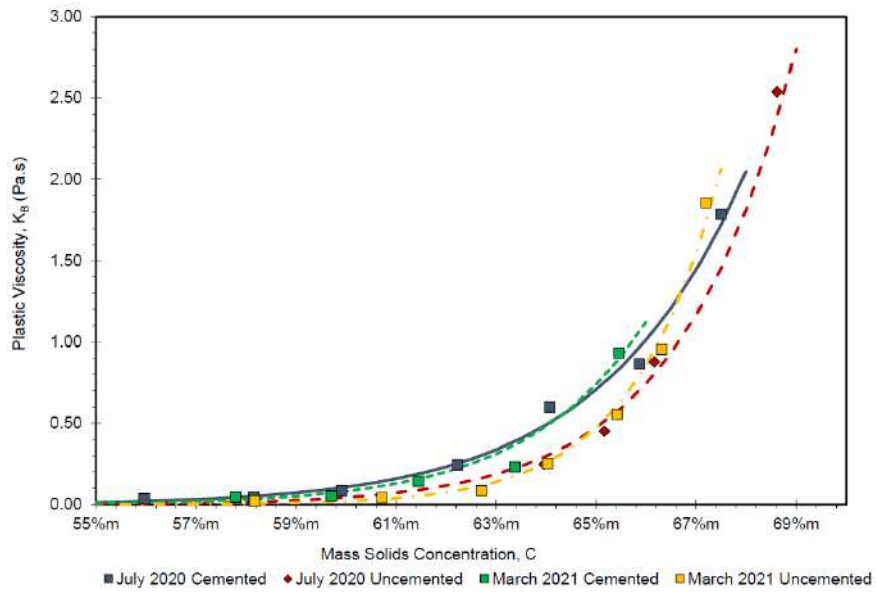

Figure 13-15: Plastic viscosity vs. mass solids concentration



13.4.1.5 Strength Testwork at Patterson & Cooke

Strength testwork was conducted at various paste recipes for a range of solids mass concentration and binder content. This was to evaluate the effects of variable binder concentrations on paste backfill strength over a range of different cure times. Two different types of binder were tested: General usage type cement (Type GU) and TerraFlow by Lafarge.

Compressive test results are presented in Table 13-23 and Table 13-24 for the July 2020 and March 2021 samples, respectively, and shown in Figure 13-16. In 2021, after discussion with the mining design team, it was determined UCS tests at 56 and 180 days were not required.

The water present in a unit of backfill per unit of binder required (water:binder ratio) versus the strength exhibited is shown in Figure 13-17 and Figure 13-18.

Based on rock mechanic engineering requirements (A. Ouellet, "RE: Final version of rock engineering report in support of 2021 PEA", May 17, 2022), a UCS value of 175 kPa is required after 14 days. This value can be met with several testing conditions.

Table 13-23: Unconfined compressive test (UCS) results for July 2020 tailings

Mix	Binder Type	Binder Concentration (%)	As Cast Mass Concentration (%m)	Water:Binder Ratio	UCS (kPa)			
					7 Days	28 Days	56 Days	180 Days
1	Type GU	15.3	69.3	2.9	1,404	2,180	2,119	-
2	Type GU	7.7	69.2	5.8	441	594	717	1,275
3	Type GU	5.1	69.1	8.8	261	410	326	565
4	Type GU	3.8	68.6	12.2	196	264	282	258
5	TerraFlow	15.3	68.5	3.0	1,731	3,401	3,704	-
6	TerraFlow	7.7	68.7	5.9	637	1,992	2,497	-
7	TerraFlow	5.1	68.8	8.9	341	1,100	1,185	1,218
8	TerraFlow	3.8	68.9	11.9	229	603	800	807



Table 13-24: Unconfined compressive test (UCS) results for March 2021 tailings

Mix	Binder Type	Binder Concentration (%)	As Cast Mass Concentration (%m)	Water:Binder Ratio	UCS (kPa)	
					7 Days	28 Days
1	Type GU	15.7	68.5	2.92	999	1,168
2	Type GU	7.8	68.6	5.86	330	345
3	Type GU	5.2	68.6	8.82	161	157
4	TerraFlow	15.7	68.5	2.93	1,753	4,262
5	TerraFlow	7.8	68.5	5.90	642	1,961
6	TerraFlow	5.2	68.9	8.66	327	1,274
7	TerraFlow	3.9	68.1	12.00	123	768

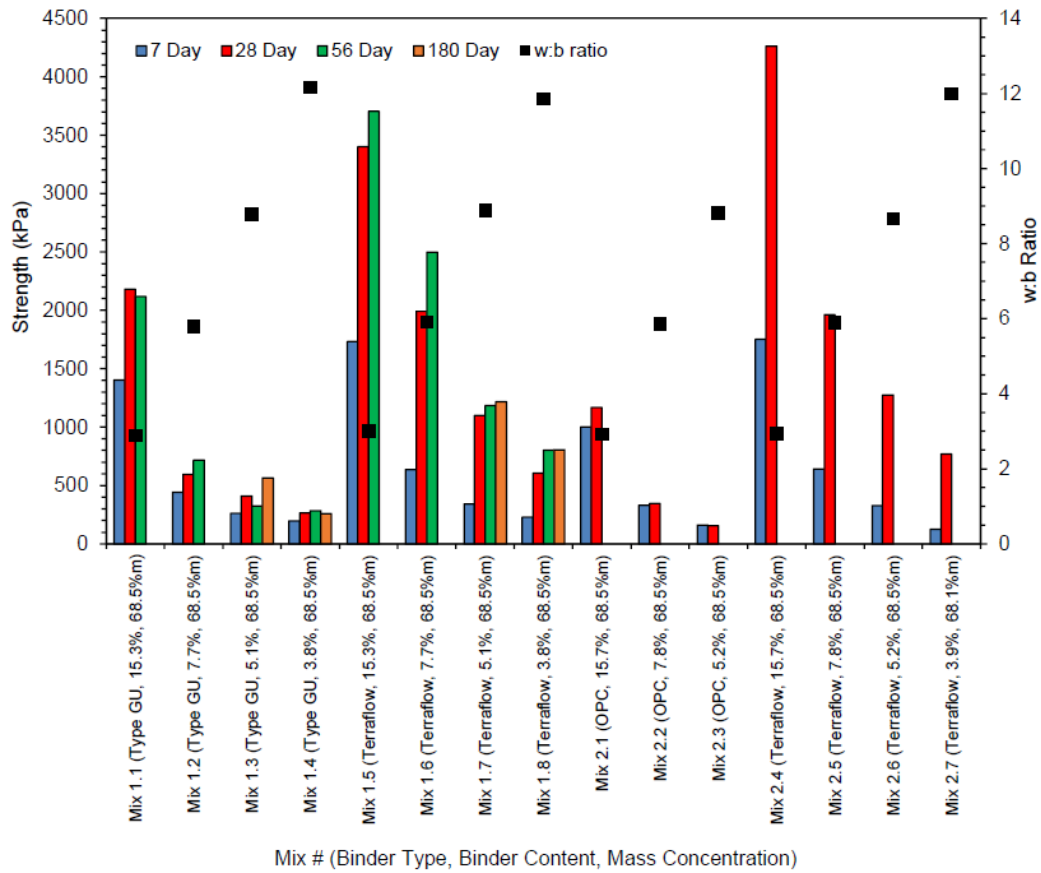

Figure 13-16: UCS test results

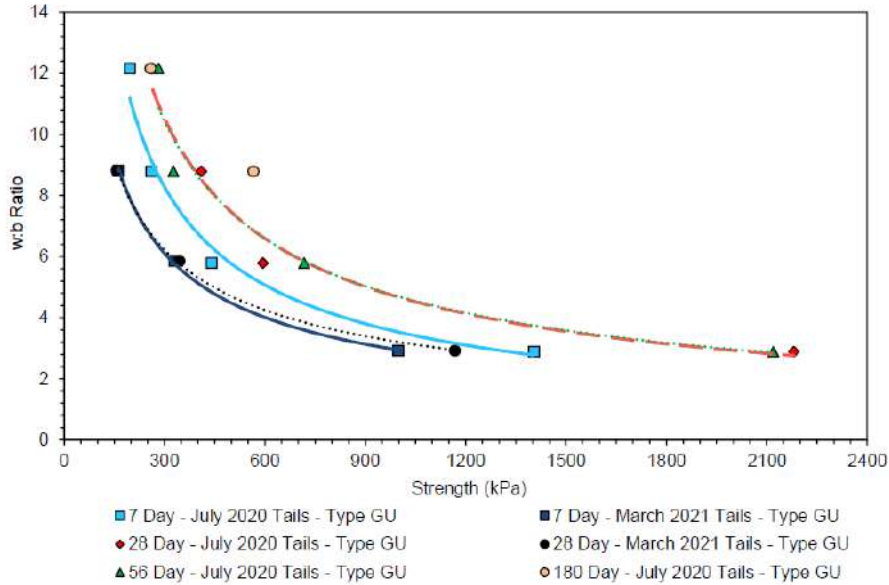

Figure 13-17: Water-to-binder ratio curves with "Type GU" binder

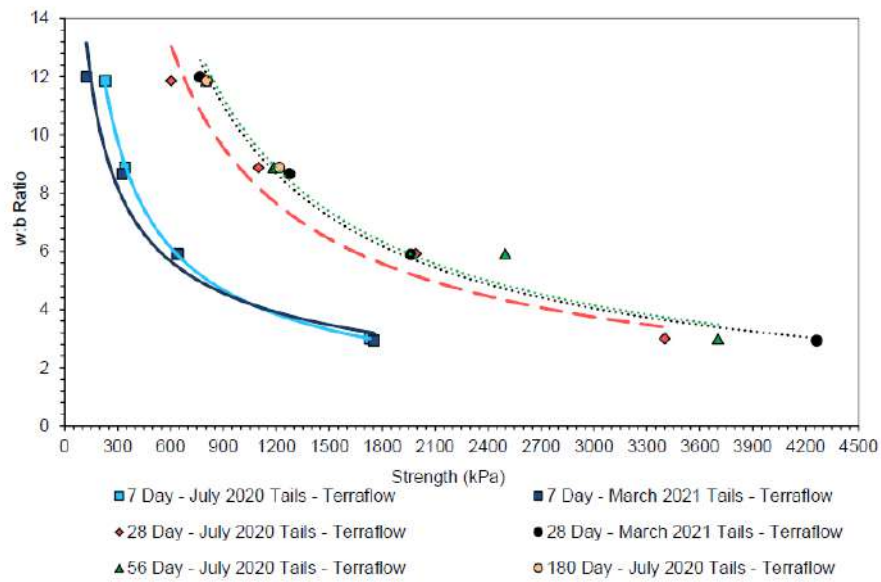

Figure 13-18: Water-to-binder ratio curves with "TerraFlow" binder



13.4.2 Feasibility Study Testwork

13.4.2.1 Physicochemical Analysis at Golder

Golder conducted measurements of the tailings particle size distribution, the SG, pH and temperature of the two samples. The average results for both samples are presented in Table 13-25.

Table 13-25: Tailings physicochemical analysis

Characteristic	Tailings 37 µm	Tailings 20 µm
D80 (µm)	34	28
D60 (µm)	20	18
D50 (µm)	16	15
D30 (µm)	10	9
D10 (µm)	5	4
pH	8.3	8.2
Temperature (°C)	21	20
Specific gravity (-)	2.80	2.81

13.4.2.2 Minerology and Chemical Analysis at Golder

Chemical and mineralogical analyses were performed and results are shown in Table 13-26 and Table 13-27.

Table 13-26: Chemical composition (wt%)

Compound	Tailings 37 µm	Tailings 20 µm
S	1.73	1.64
Al ₂ O ₃	11.79	11.93
BaO	0.1	0.1
CaO	3.56	3.56
Co ₃ O ₂	0.0025	0.003
Cr ₂ O ₃	0.03	0.04
CuO	0.009	0.008
Fe ₂ O ₃	5.48	5.94
K ₂ O	2.48	2.50
LOI	6.03	5.53



Compound	Tailings 37 µm	Tailings 20 µm
MgO	2.29	2.29
MnO	0.089	0.094
Na ₂ O	0.68	0.70
NiO	0.01	0.008
P ₂ O ₅	0.07	0.07
SiO ₂	64.26	64.79
SrO	0.009	0.008
TiO ₂	0.36	0.35
V ₂ O ₅	0.018	0.017
Total ICP	97.21	97.64

Table 13-27: Semi-quantitative mineralogical composition (phase wt%)

Mineral SQ-XRD	Chemical Composition	Tailings 37 µm	Tailings 20 µm
Quartz	SiO ₂	57.83	58.52
Muscovite	KAl ₂ (Si,Al) ₄ O ₁₀ (OH) ₂	9.81	11.96
Clinochlore/Chlorite	(Mg,Fe) ₆ (Si,Al) ₄ O ₁₀ (OH) ₈	8.60	8.23
Diopside	Ca(MgAl)(SiAl) ₂ O ₆	7.97	6.90
Ankerite	Ca(Mg _{0.67} Fe _{0.33} ⁺²)(CO ₃) ₂	6.63	6.37
Albite	NaAlSi ₃ O ₈	6.23	4.61
Pyrite	FeS ₂	2.05	2.06
Magnetite	Fe ₃ O ₄	0.88	1.35
Total		100.00	100.00

13.4.2.3 Rheological Characterization at Golder

Both samples were tested for different rheological characterizations. Results for sample Tailings 37 µm are reported in detail here.

The solids content to obtain a 178-mm (7") slump was 70.9% and 67.8% for sample Tailings 37 µm and Tailings 20 µm, respectively. The correlation for sample Tailings 37 µm is shown in Figure 13-19.

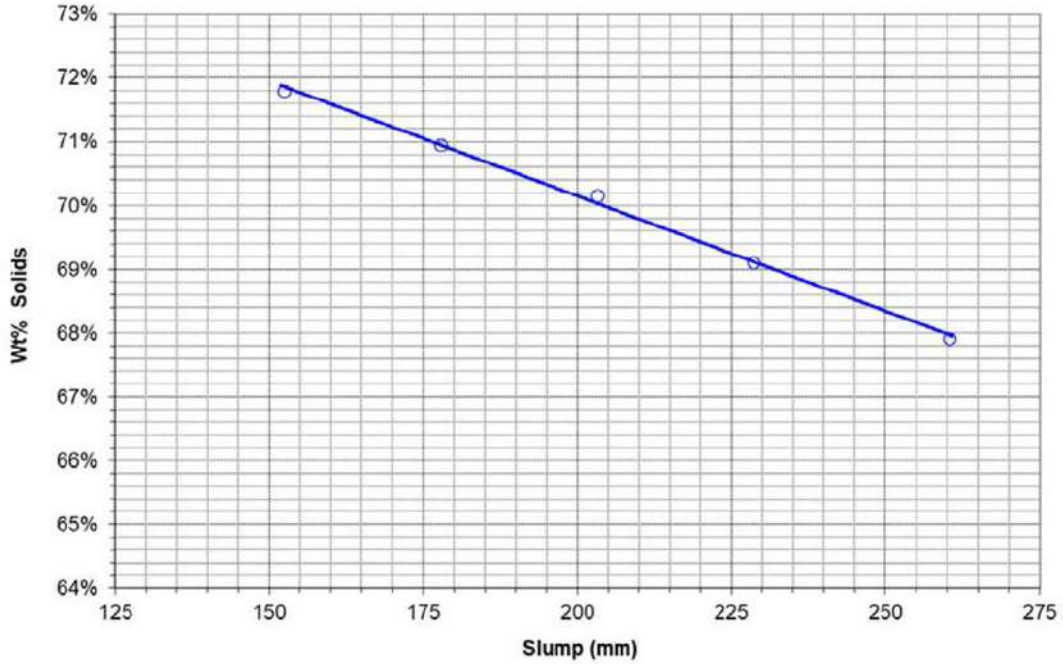

Figure 13-19: %Solids vs. slump for Tailings 37 µm sample

Static yield stress was determined and the results for sample Tailings 37 µm are shown in Figure 13-20.

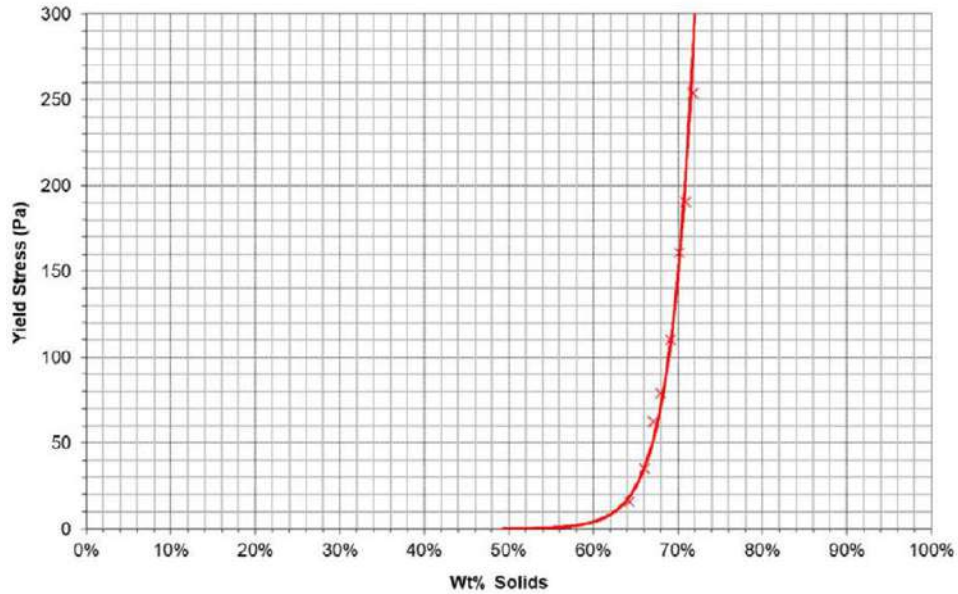

Figure 13-20: Static yield stress vs. %solids for Tailings 37 µm sample

To assess the water bleed properties of the paste while sitting idle in test beakers, a moisture retention testing was carried out. Two slump consistencies (178 mm and 254 mm) were tested at four-time intervals. At each time interval the water bleed and yield stress were measured. Results for sample Tailings 37 µm are shown in Figure 13-21.

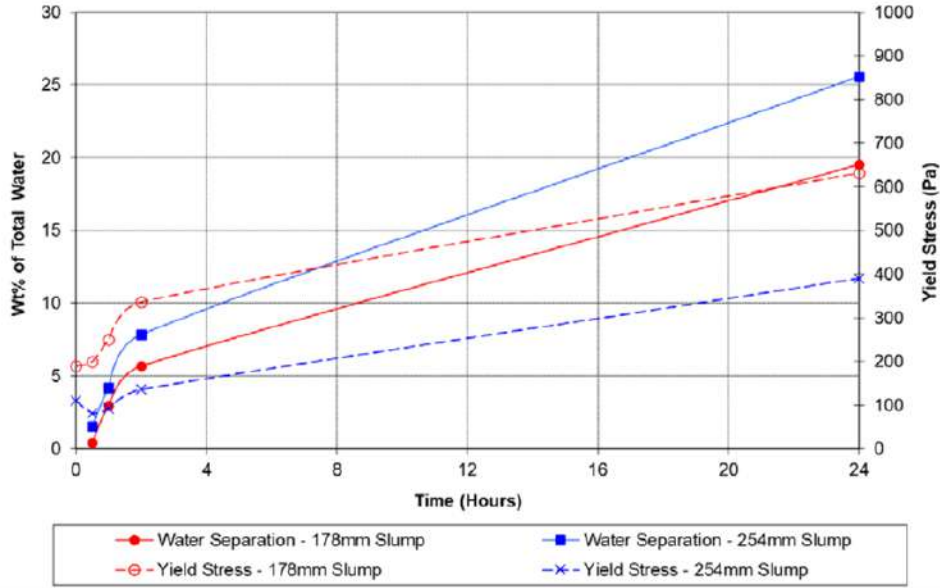

Figure 13-21: Water bleed and yield stress vs. time for Tailings 37 µm sample

Plug yield stress analysis was performed. Results for sample Tailings 37 µm are shown in Figure 13-22.

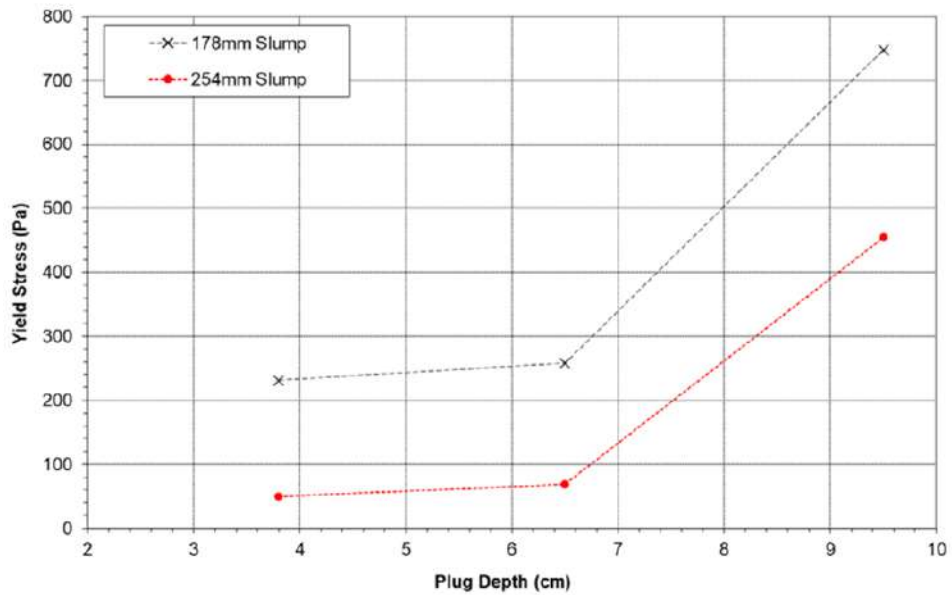

Figure 13-22: Plug yield stress for Tailings 37 µm sample



The yield stress determined through Golder's testing is referred to as dynamic yield stress. Results for sample Tailings 37 μm are shown in Table 13-28 and presented in Figure 13-23 and Figure 13-24.

Table 13-28: Bingham viscosity and yield stress summary for Tailings 37 μm sample

Solids Content (wt%)	Bingham Yield Stress (Pa)		Bingham Viscosity (Pa-s)	
	Ramp Up	Ramp Down	Ramp Up	Ramp Down
71.4	723	358	1.629	2.218
70.1	379	359	1.287	1.395
69.4	258	195	0.881	0.956
67.8	148	112	0.485	0.551
66.4	81	67	0.255	0.280
62.7	27	26	0.074	0.078

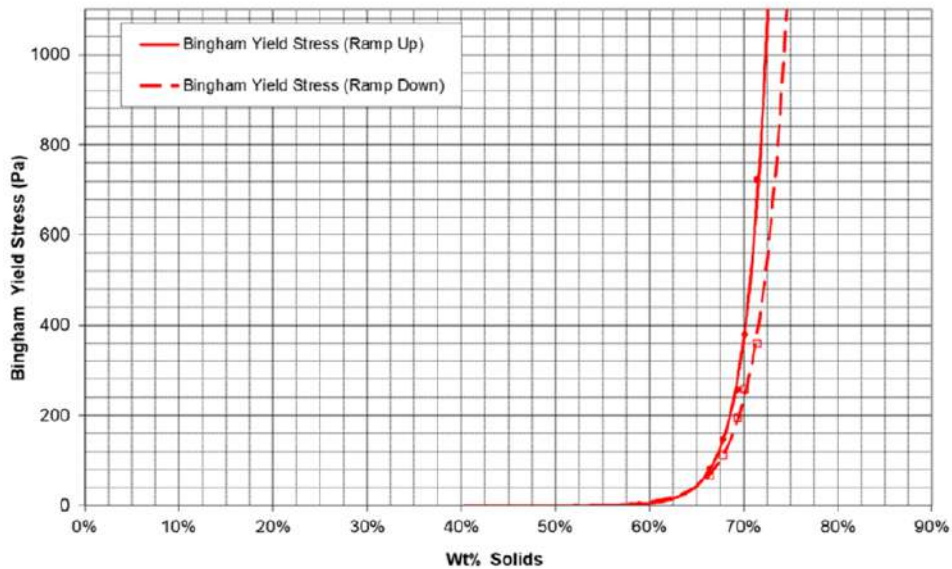

Figure 13-23: Bingham yield stress results for sample Tailings 37 μm sample

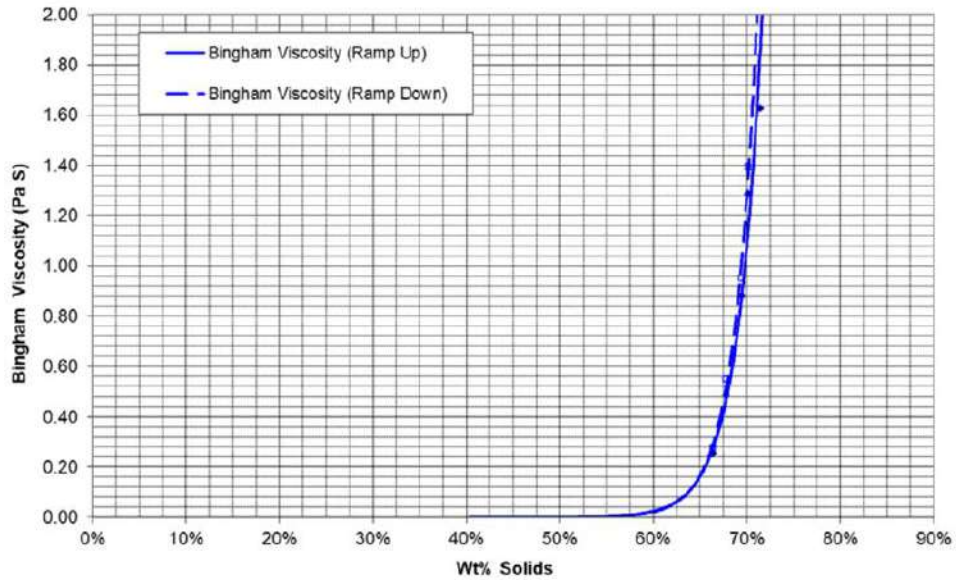

Figure 13-24: Bingham viscosity results for sample Tailings 37 µm sample

13.4.2.4 Flow Loop Testing at Golder

Flow loop testing to determine information for pump selection and pipeline distribution systems has been performed. Results are summarized in Figure 13-25. The y-intercept representing the yield stress is schematized in Figure 13-26 and to the slope, which corresponds to the viscosity is schematized in Figure 13-27.

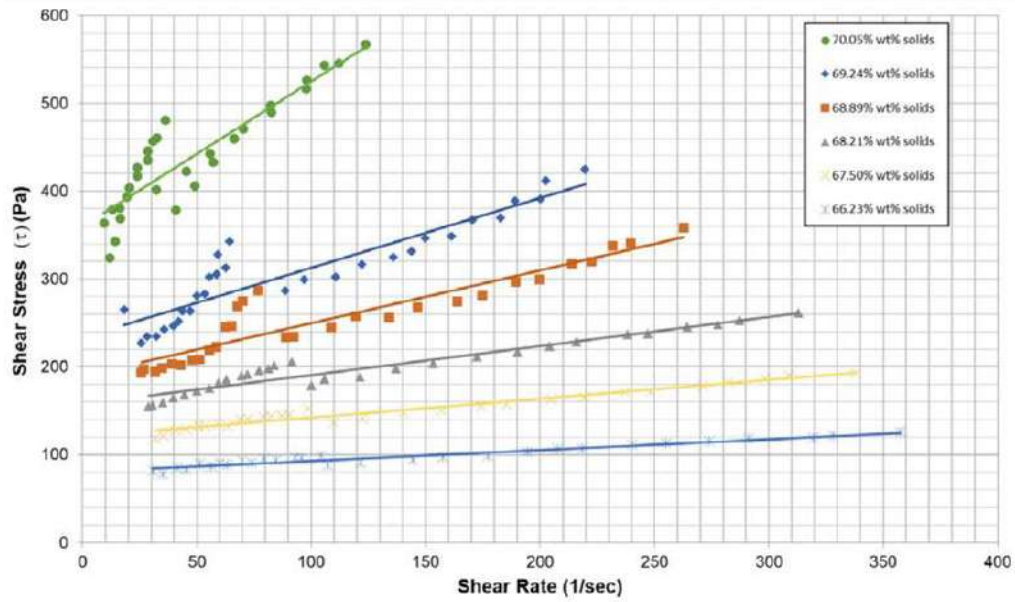

Figure 13-25: Flow loop data summary

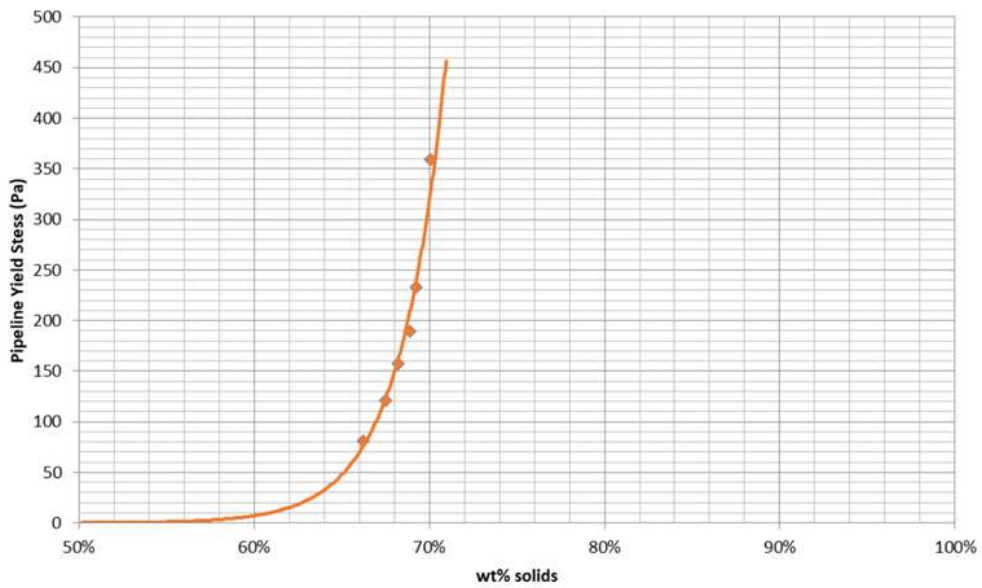

Figure 13-26: Pipeline yield stress vs. wt% solids

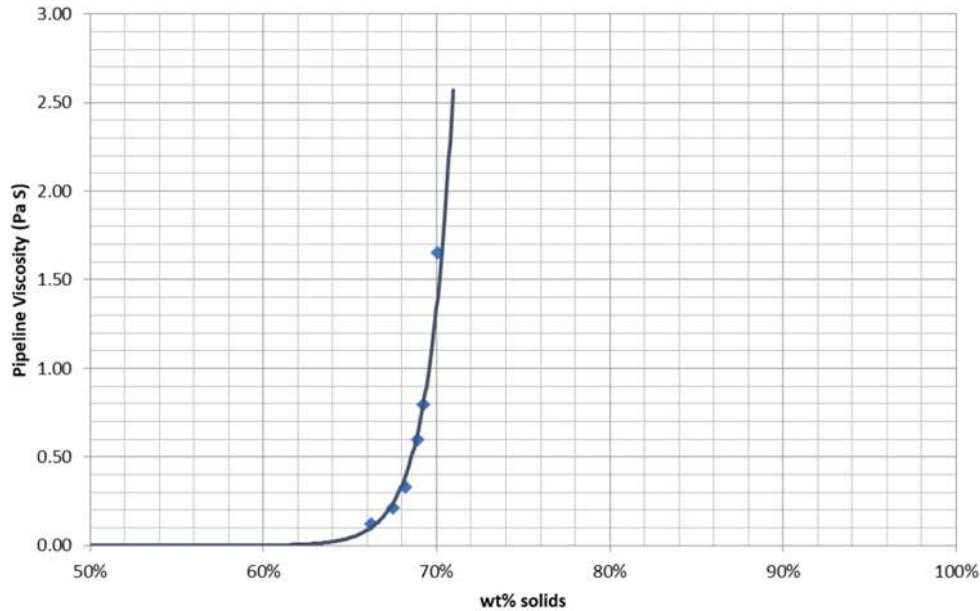

Figure 13-27: Pipeline viscosity vs. wt% solids

13.4.2.5 Unconfined Compressive Strength Testing at Golder

The unconfined compressive strength (“UCS”) testing program was performed to assess the backfill strength using 76 mm x 152 mm (3" x 6") cylinders for the Tailings 37 μm sample and 51 mm x 102 mm (2" x 4") cylinders for the Tailings 20 μm sample. For sample Tailings 37 μm , three cylinders per curing period were cast and two or four cylinders were cast for sample Tailings 20 μm . The results were averaged and are presented in Table 13-29 and Figure 13-28.



Table 13-29: UCS tests results

Mix	Binder (Wt%)	Binder (type)	Sample	Slump (mm)	Average UCS (kPa)					Average Bulk Density (kg/m ³)
					Curing days					
					7	14	28	56	90	
1	2	Lafarge Type 10	Tailings 37 µm	178	62		68	68	59	1,832
2	2			254	4 ⁽¹⁾	44	68	65	51	1,785
3	4			178	124		175	163	144	1,823
4	4			254	75		140	133	100	1,799
5	6			178	241		286	286	271	1,843
6	6			254	168		219	206	221	1,798
7	2	Lafarge 90/10 (BFS/ Type 10)	Tailings 37 µm	178	11 ⁽¹⁾	54	166	314	331	1,877
8	2			254	4 ⁽¹⁾	34	175	276	308	1,838
9	4			178	215		929	1,339	1,471	1,871
10	4			254	180		794	1,037	1,294	1,844
11	6			178	475		1,684	2,070	2,302	1,871
12	6			254	228		1,039	1,501	1,664	1,820
13	2	Lafarge Type 10	Tailings 20 m	178	42		60	109	96	1,823
14	2			254	27 ⁽¹⁾	32	63		61	1,773
15	4			178	163		168 140 ⁽²⁾	188	163	1,815
16	4			254	94		116	142	126	1,797
17	6			178	219		281	305		1,850
18	6			254	150		175			1,782
19	2	Lafarge 90/10 (BFS/ Type 10)	Tailings 20 m	178	27 ⁽¹⁾	88	177	238	298	1,834
20	2			254	27 ⁽¹⁾	90	207		305	1,816
21	4			178	337		915 749 ⁽²⁾	1,131	1,010	1,876
22	4			254	189		720	804	877	1,809
23	6			178	214		1,172	1,791		1,827
24	6			254	389		1,028	1,028		1,814

⁽¹⁾ Too soft to demold, strength measurement obtained with penetrometer; UCS completed at 14 days instead of 7 days.

⁽²⁾ Comparison 76 mm x 152 mm cylinder UCS results.

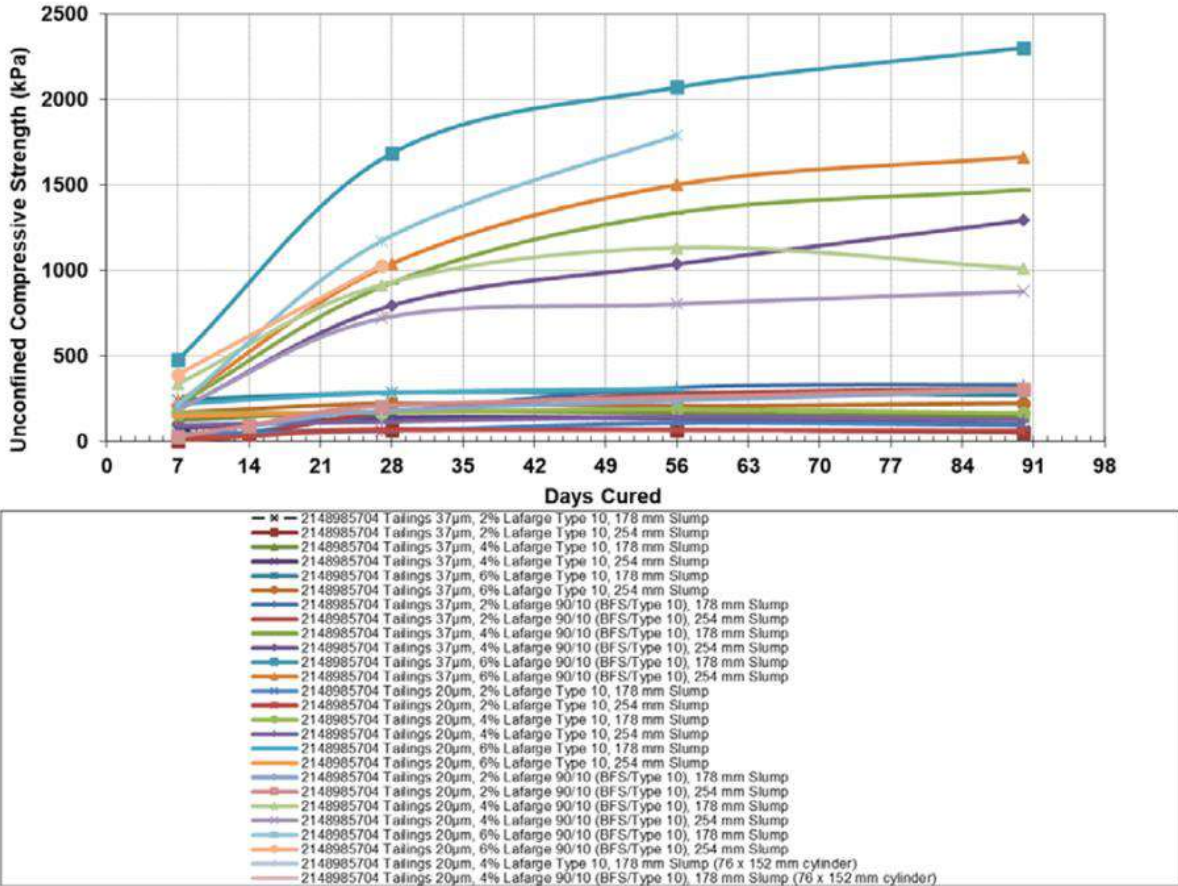

Figure 13-28: UCS results for samples Tailings 37 and 20 µm

13.4.2.6 Physicochemical Analysis at Metso:Outotec

The samples SG and P₈₀ for each barrel are summarized in Table 13-30.

Table 13-30: Lynx bulk tailings physicochemical analysis

Sub-sample	SG	P ₈₀ (µm)
Barrel #1	2.82	41
Barrel #2	2.82	46
Barrel #3	2.84	40
Barrel #4	2.82	45



13.4.2.7 Thickening Testwork at Metso:Outotec

The purpose of the testwork was to determine the thickening characteristics and obtain the design criteria suitable for sizing purposes, mainly:

- Flocculant type and dosage;
- Overflow clarity;
- Underflow density;
- Underflow yield stress.

Some of the results were compared to previous results obtained on a similar material (P₈₀ of 37 µm) in February 2021.

13.4.2.7.1 Flocculant Selection

All flocculants produced visually clear overflow after 20 g/t. SNF 905 VHM had the best overall performance with the quickest settling rate at the lower flocculant dosages. Previous thickening testwork completed in February 2021 had used SNF 910 SH and has shown to perform well on the Lynx bulk tailings sample. For consistency and comparison purpose with previous testwork, all dynamic thickening were done using SNF 910 SH. Figure 13-29 presents the results.

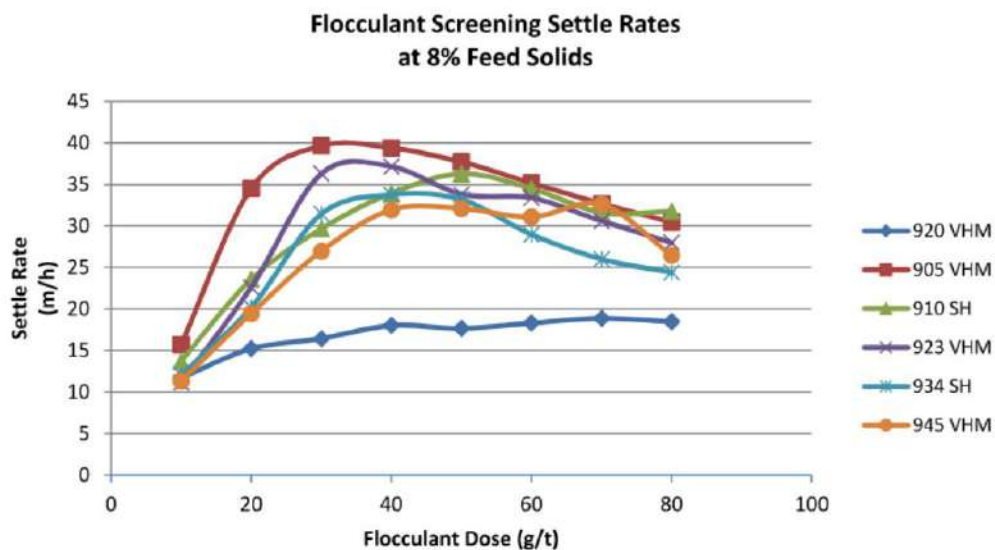

Figure 13-29: Lynx bulk tailings flocculant screening results



13.4.2.7.2 Feed Dilution Tests

The optimum feed slurry concentration for the Lynx bulk tailings sample was found to be 15% solids when adding flocculant.

13.4.2.7.3 Dynamic Thickening Tests

Results of dynamic thickening tests based on different solids loading rates and flocculant dosages are summarized in Table 13-31.

Table 13-31: Dynamic thickening results summary

Run No.	Feed		Flocculant		Underflow		Overflow
	Flux (t/(m ² ·h))	Liquor RR (m/h)	Type	Dose (g/t)	Meas. Solids (%(w/w))	YS (Pa)	Solids (mg/L)
1	0.80	4.83	910 SH	30	56.1	5	< 100
2	0.80	4.83	910 SH	20	56.4	4	< 100
3	0.80	4.83	910 SH	10	55.5	3	< 100
4	0.40	2.41	910 SH	20	59.7	8	< 100
4-HCT ⁽¹⁾	0.40	2.41	910 SH	20	64.6	30	< 100
5	0.30	1.81	910 SH	20	62.5	30	< 100
5-HCT ⁽¹⁾	0.30	1.81	910 SH	20	66.1	61	< 100
8	0.25	1.51	910 SH	20	63.7	40	< 100
8-HCT ⁽¹⁾	0.25	1.51	910 SH	20	66.7	91	< 100
6	0.20	1.21	910 SH	20	64.9	43	< 100
6-HCT ⁽¹⁾	0.20	1.21	910 SH	20	67.2	86	< 100
7	0.30	1.81	905 VHM	20	62.3	37	< 100
7-HCT ⁽¹⁾	0.30	1.81	905 VHM	20	66.0	67	< 100

⁽¹⁾ High-compression simulation test performed.

It was determined that for all dynamic runs, the overflow clarity was visually clear and was less than 100 ppm. The solids loading rates were tested over a range from 0.2 t - 0.8 t/(m²·h) and reached a peak underflow value of approximately 65% solids at a solids loading rate of 0.2 t/(m²·h). Measured underflow yield stresses were between 3 Pa and 91 Pa.

The peak high-compression test ("HCT") underflow was 67% solids at a solids loading rate of 0.2 t/(m²·h). An additional 2-3% in underflow density was achieved while using high-compression versus HRT. Figure 13-30 presents a comparison of the change in underflow solids content at the different particle sizes tested. Included for comparison are the underflow values when using HCT versus HRT on the Lynx bulk tailings sample.

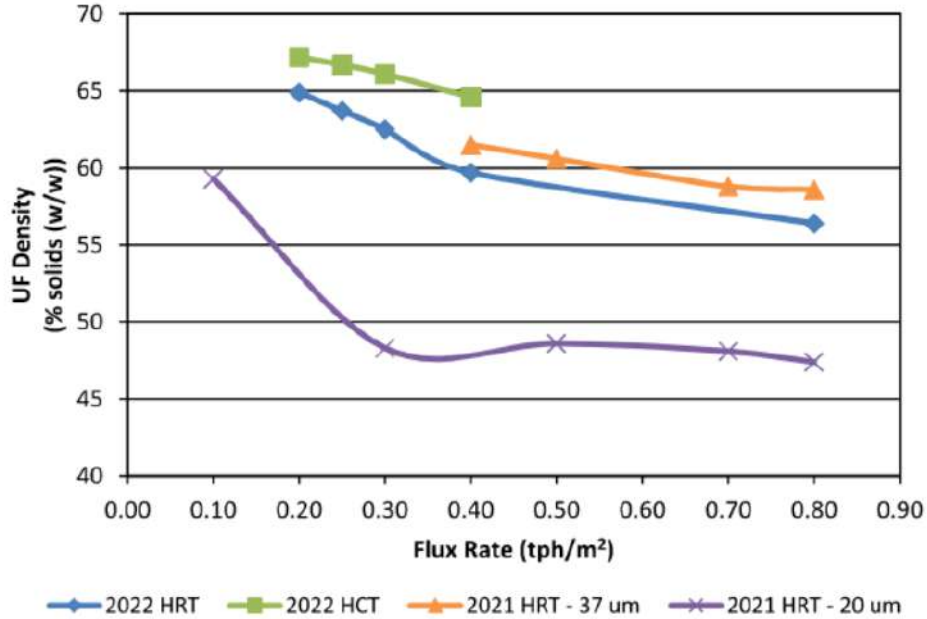

Figure 13-30: Historical underflow solids content comparison for different P₈₀

The pilot plant dynamic thickening testwork showed that a peak underflow value of approximately 69% solids was achieved just as the bed height reached 3 m prior to the start of the continuous operation. During continuous operation, a peak underflow value of approximately 61% was achieved. Figure 13-31 shows the results.

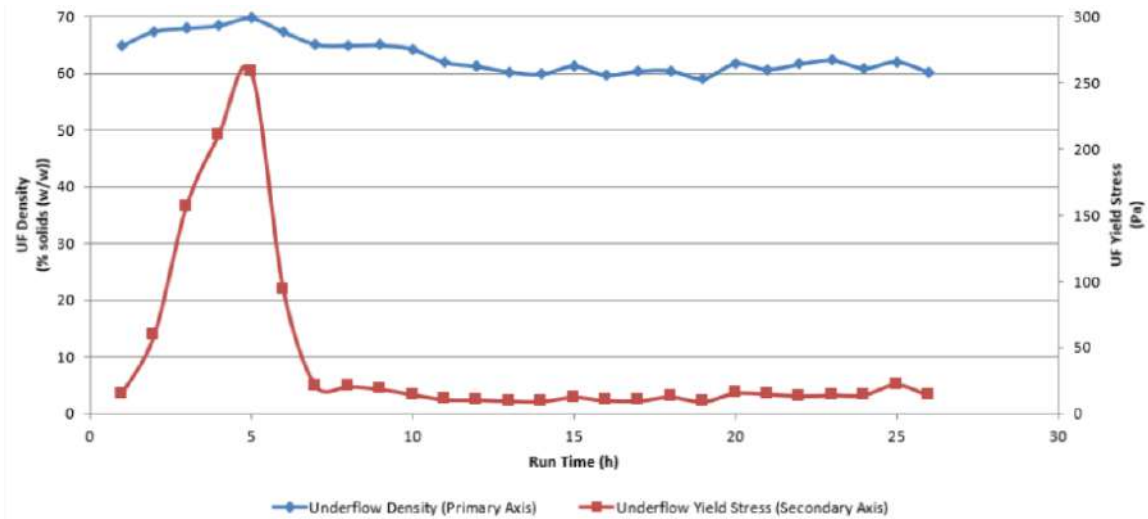

Figure 13-31: 190-mm pilot yield stress and underflow values produced during run time

Higher underflow values during continuous operation were not attainable since the bed was ratholing and excess water was passing through reducing the overall underflow solids content.

Based on the yield stress curve shown in Figure 13-32, underflow densities greater than 66% solids yielded stresses that were above 50 Pa.

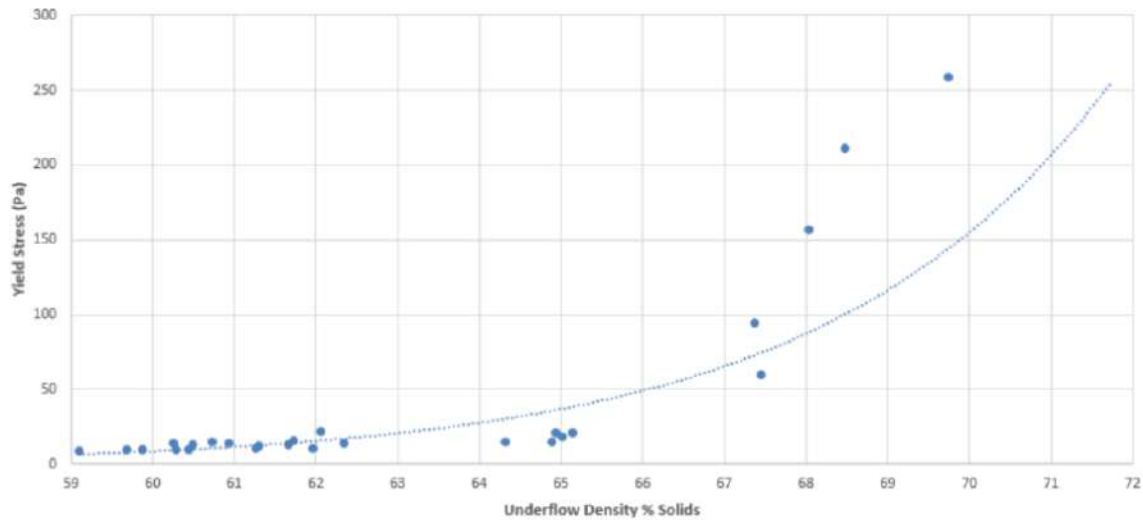

Figure 13-32: 190-mm pilot yield stress vs. underflow solids content



13.4.2.8 Filtration Testwork at Metso:Outotec

The purpose of the testwork was to explore the filtering characteristics of the sample and provide aid in determining the sizing and process design criteria for the feasibility study. The tests were conducted on the Lynx bulk tailings sample following thickening testing. In addition to generate design data for filter sizing, testwork allowed to determine:

- Plate selection;
- Cake thickness;
- Filtration rate;
- Moisture content of the cake;
- Cake handling characteristics.

A total of 7 filtration runs were performed on a Larox 100 test filter using a feed density of about 60% solids and a Mito S171 filter cloth. Table 13-32 presents the tests parameters and results.

Table 13-32: Lynx bulk tailings filtration tests parameters and results

Parameters	Unit	Run #1	Run #2	Run #3	Run #4	Run #5 ⁽¹⁾	Run #6	Run #7
Chamber depth	mm	45	45	40	40	40	50	50
Cycle time	min	8.5	8	8.5	8	8	8.5	8
Pumping pressure	bar	6	6	6	6	10	6	6
Pressing pressure	bar	12	12	12	12	10	12	12
Air drying	bar	10	10	10	10	9	10	10
Cake thickness	mm	45.1	44.6	39.4	39.3	40.5	48.4	49.2
Cake moisture	% w/w	12.22	12.02	11.70	11.90	11.58	12.70	11.86
Filtration rate D.S.	kg/m ² -h	224.3	235.2	192.9	208.1	213.2	245.9	267.1

(1) Run #5 was done using VPA mode.

The cake moisture ranged from 11.7% to 12.7% depending on the conditions used, and the cake thickness varied in function of the chamber depth. Filter cloths were easy to wash, and no cloth blinding was noticed during testing. The filtrate from all test runs initially had some solids pass through the cloth while the cake was forming but became clear after a few seconds.

The effect of air-drying time on cake moisture is presented in Figure 13-33. The moisture contents were back calculated based on the filtrate mass during the air blowing stage (air-drying cycle).

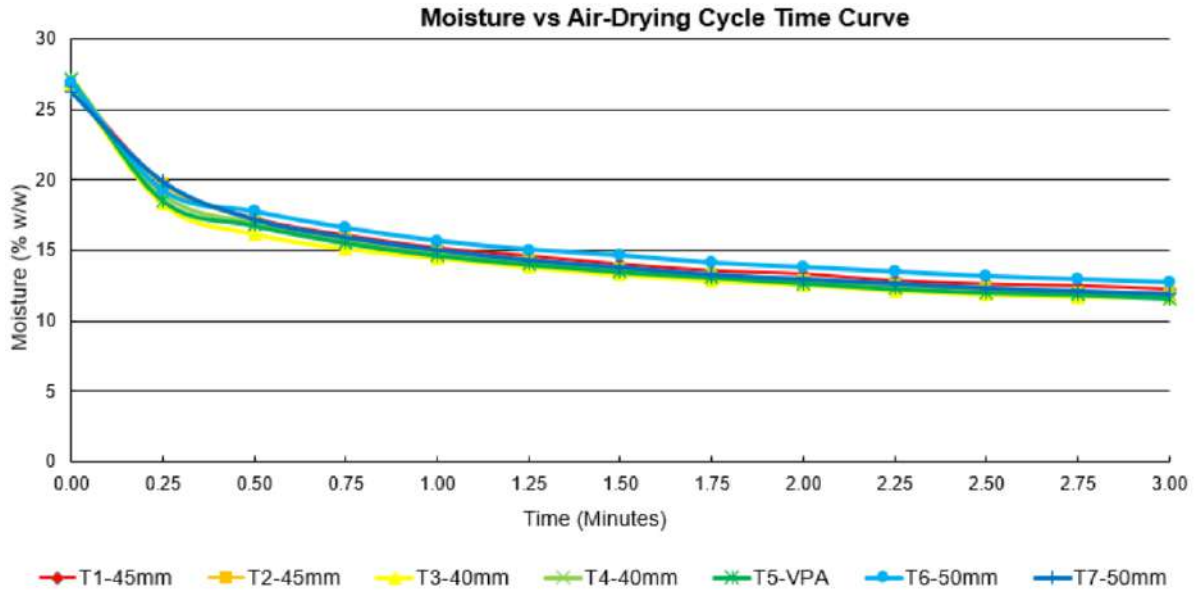

Figure 13-33: Drying time effect on cake moisture

The effect of filtration rate on cake moisture is presented in Figure 13-34.

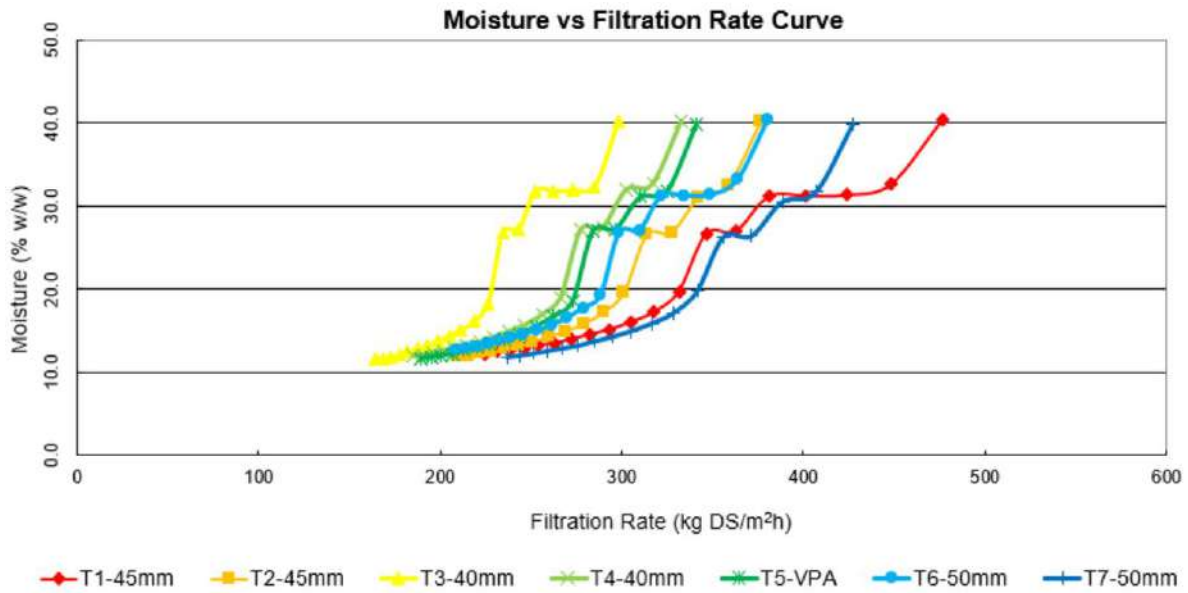

Figure 13-34: Filtration rate vs. cake moisture



13.5 Overall Recovery – Windfall

The Windfall gold and silver recoveries are the combination of the gravity recovery and the leach recovery. The distribution between the gravity recovery and leach recovery is presented in Table 13-33.

Table 13-33: Overall gold and silver recovery with gravity and leach

Composite	Gravity				Leach (Gravity tails)				Overall Au recovery (%)	Overall Ag recovery (%)
	Au distribution (%)	Ag distribution (%)	Au recovery (%)	Ag recovery (%)	Au distribution (%)	Ag distribution (%)	Au recovery (%)	Ag recovery (%)		
Main	33	21	31.9	20.6	68	79	90.0	76.1	93.2	81.1
Lynx	37	23	36.3	23.0	64	77	92.8	77.7	95.4	82.9
Triple Lynx	33	31	32.7	30.6	67	69	89.4	76.8	92.9	83.9
Lynx 4	26	18	25.2	17.5	75	82	88.9	82.6	91.7	85.6
Underdog	37	27	36.3	26.7	64	73	93.3	73.2	95.8	80.4

The gravity gold recoveries for each zone were determined by SGS e-GRG testworks and by FLS gravity circuit simulations at the cyclone U/F with intensive leach reactor. The gravity silver recovery was determined by modelling the ratio of silver and gold in the gravity concentrate versus the ratio of silver and gold in the head. The ratio of silver and gold in the gravity concentrate is found to be a different constant for each zone.

The gold and silver leach recoveries for each zone were determined by modelling the existing kinetic CIL testwork data to predict the recovery at the 24-hour retention time used for the process design criteria.

With consideration of the parameters currently in the life of mine, a relationship between the residue grade and the gold head assay has been developed based on the least square equation. A similar process has been applied for the silver. The equations are presented in the following Figure 13-35 to Figure 13-44.

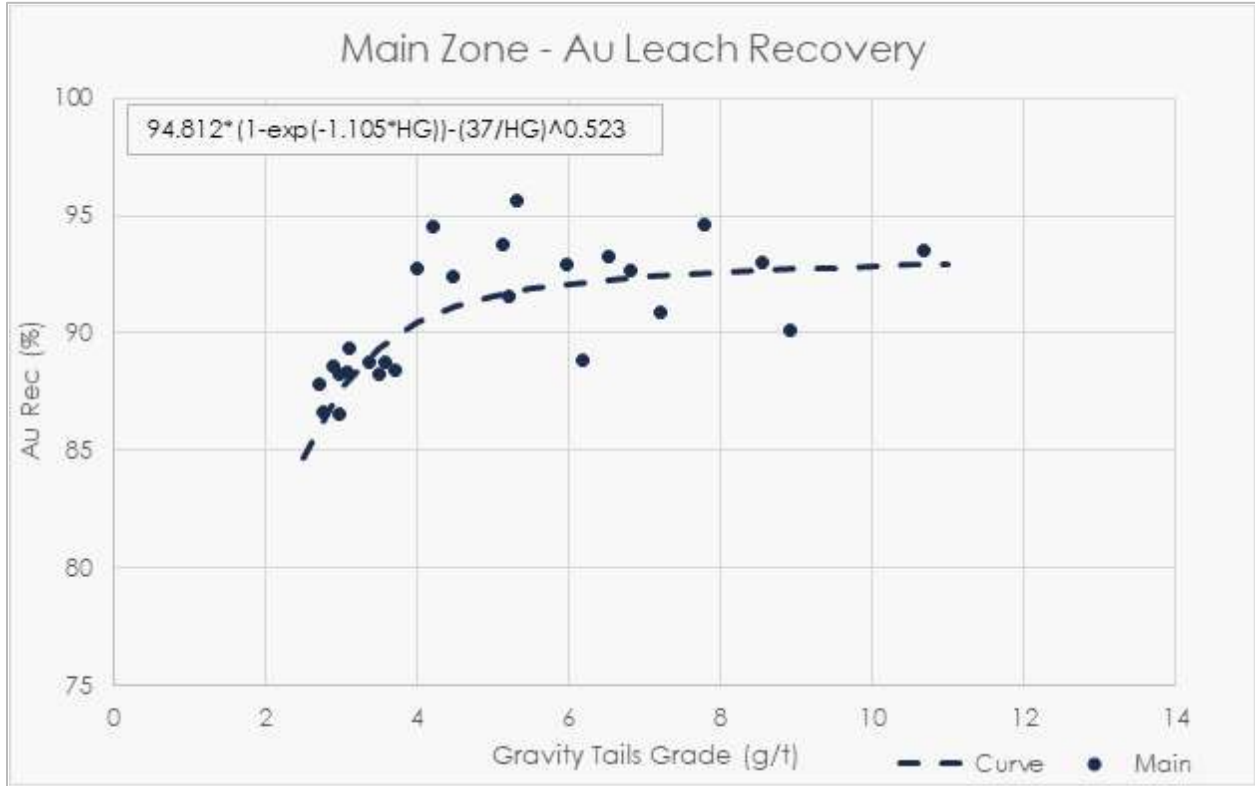

Figure 13-35: Main zone gold recovery curve

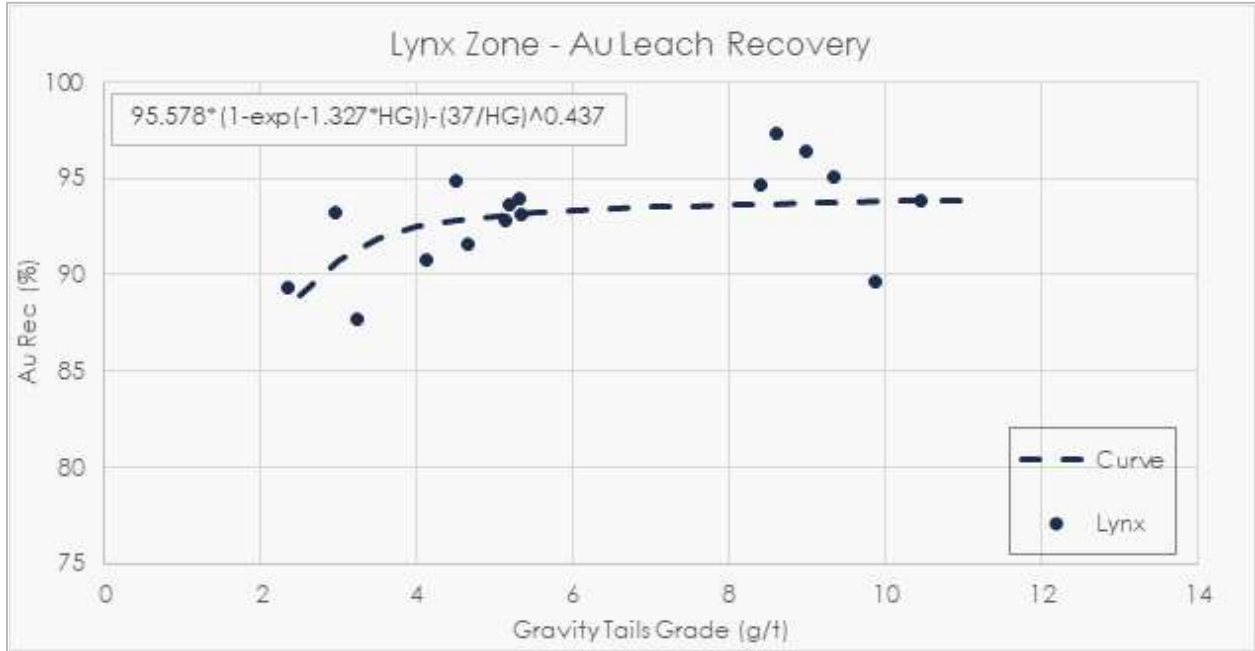

Figure 13-36: Lynx zone gold recovery curve

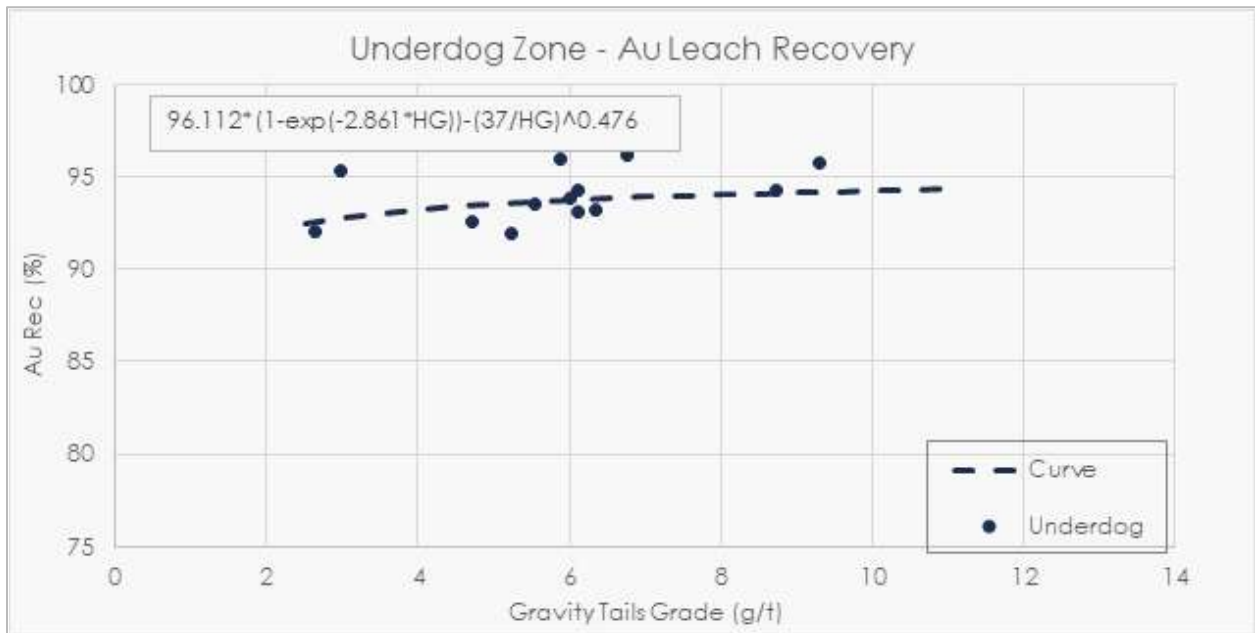

Figure 13-37: Underdog zone gold recovery curve

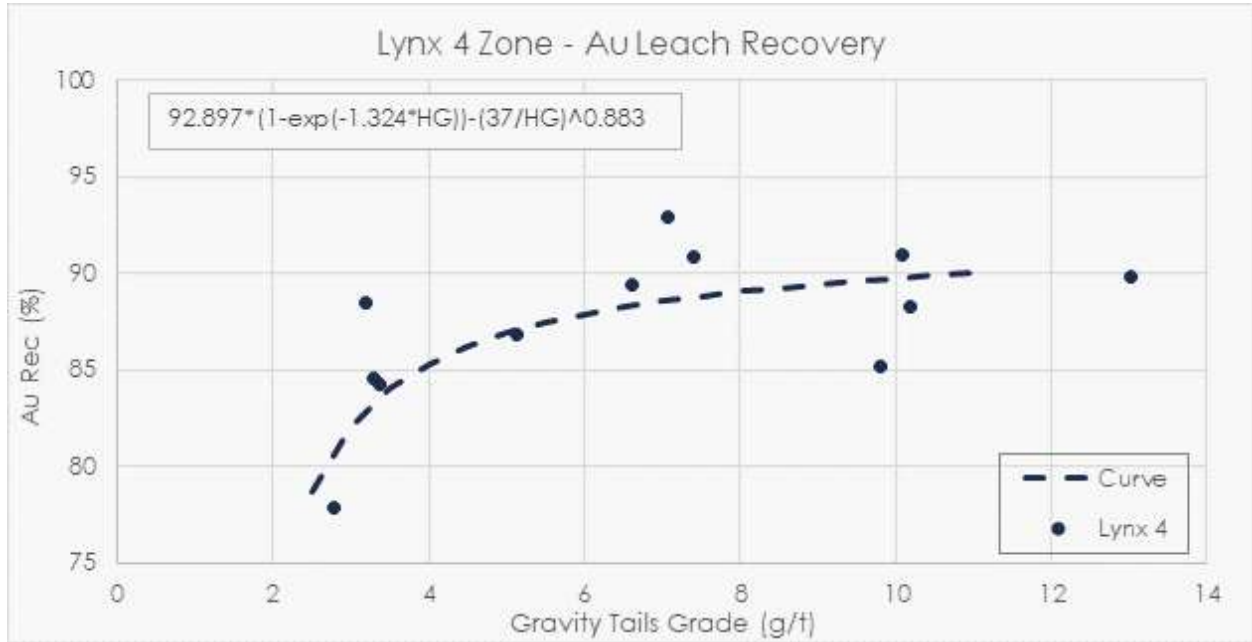

Figure 13-38: Lynx 4 zone gold recovery curve

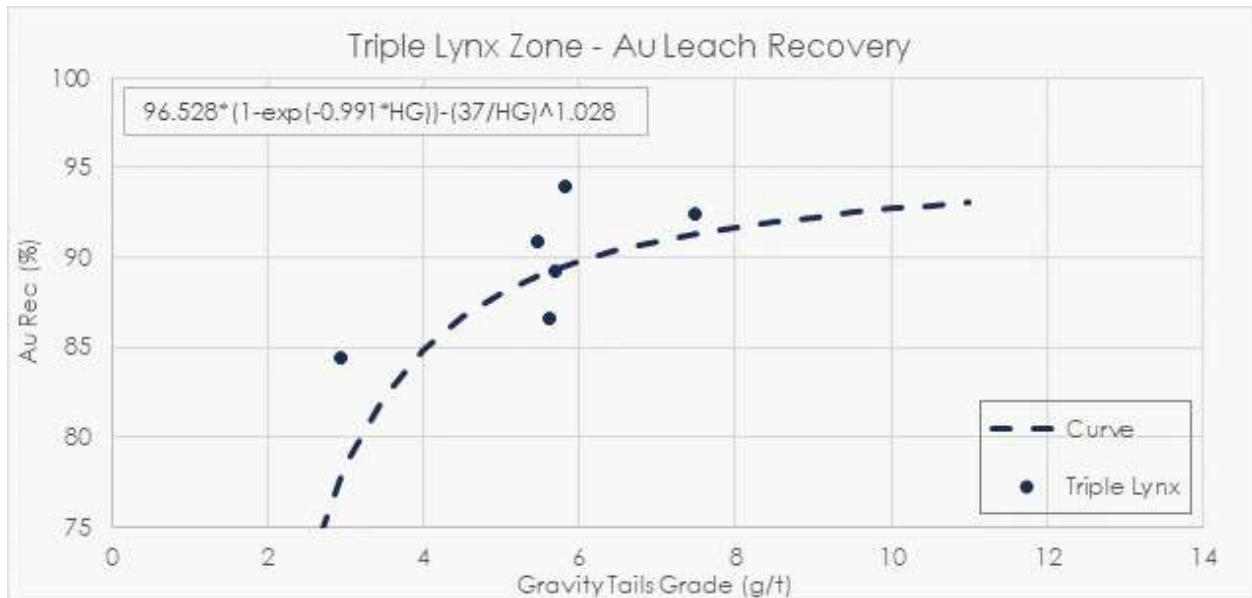

Figure 13-39: Triple Lynx zone gold recovery curve

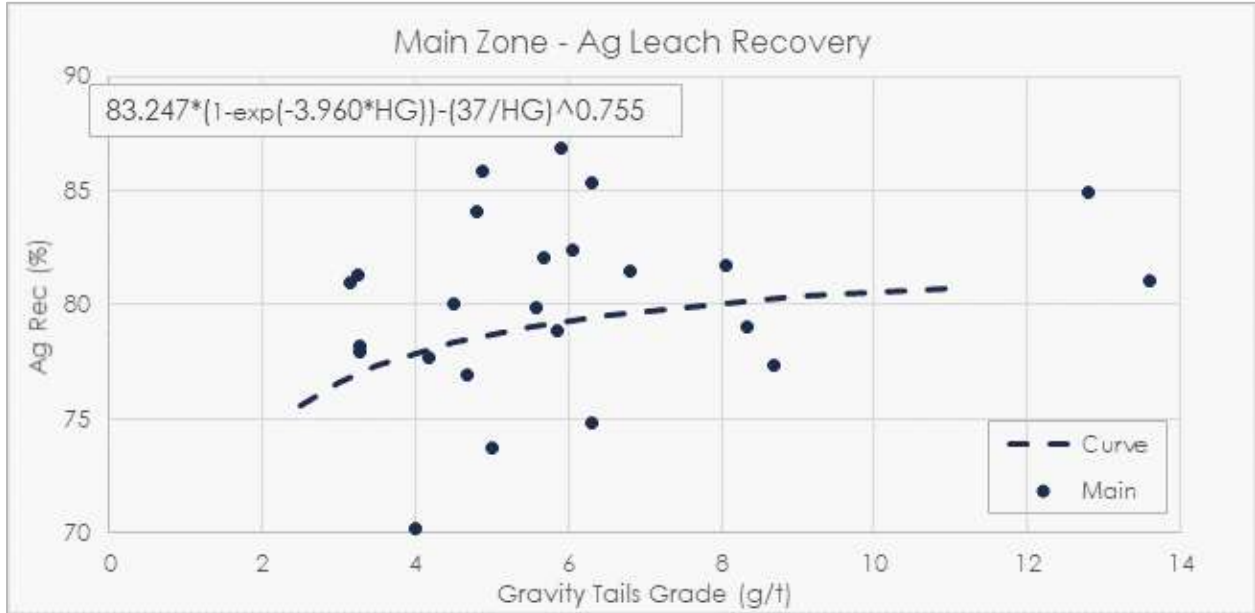

Figure 13-40: Main zone silver recovery curve

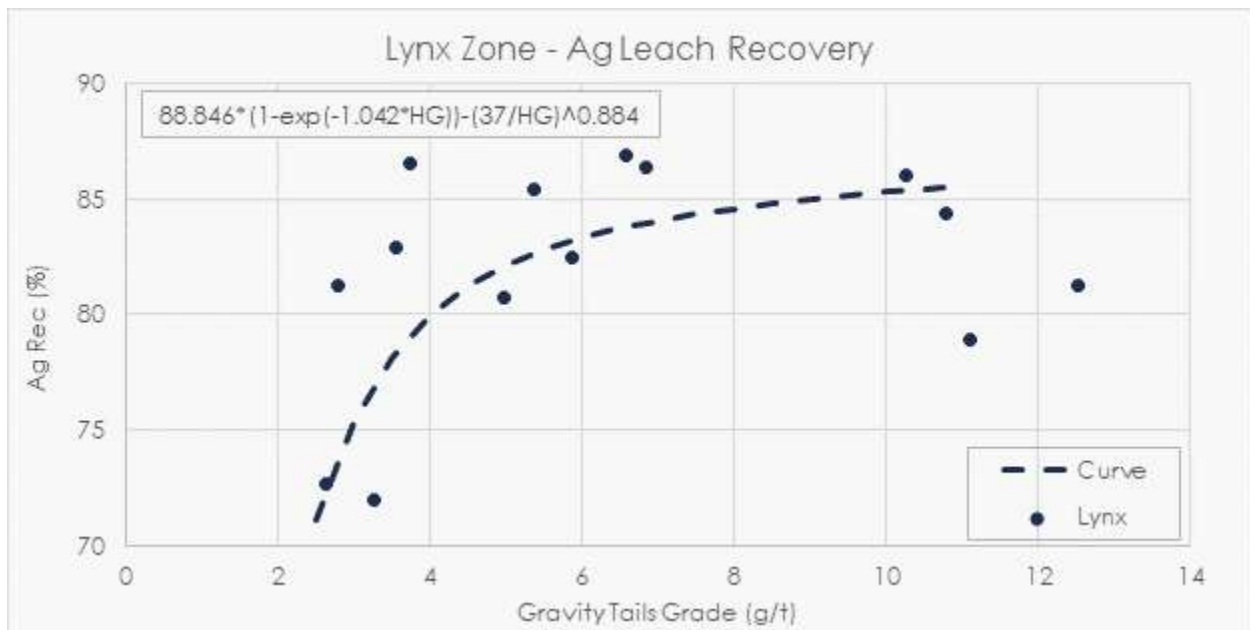

Figure 13-41: Lynx zone silver recovery curve

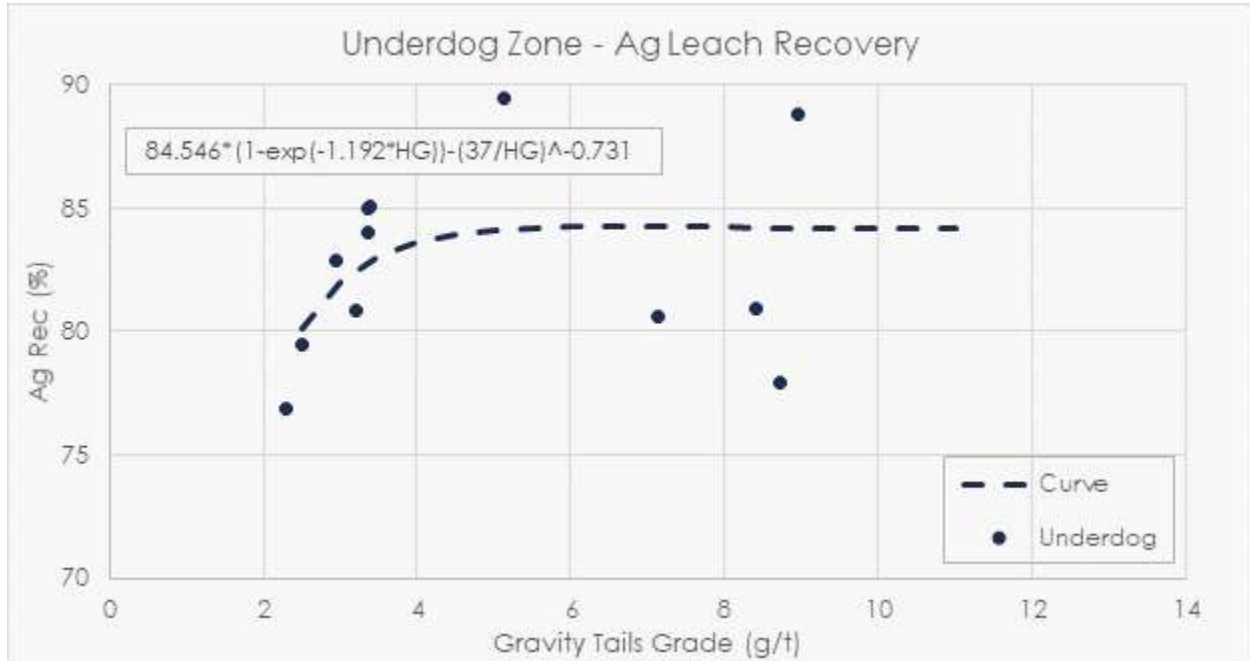

Figure 13-42: Underdog zone silver recovery curve

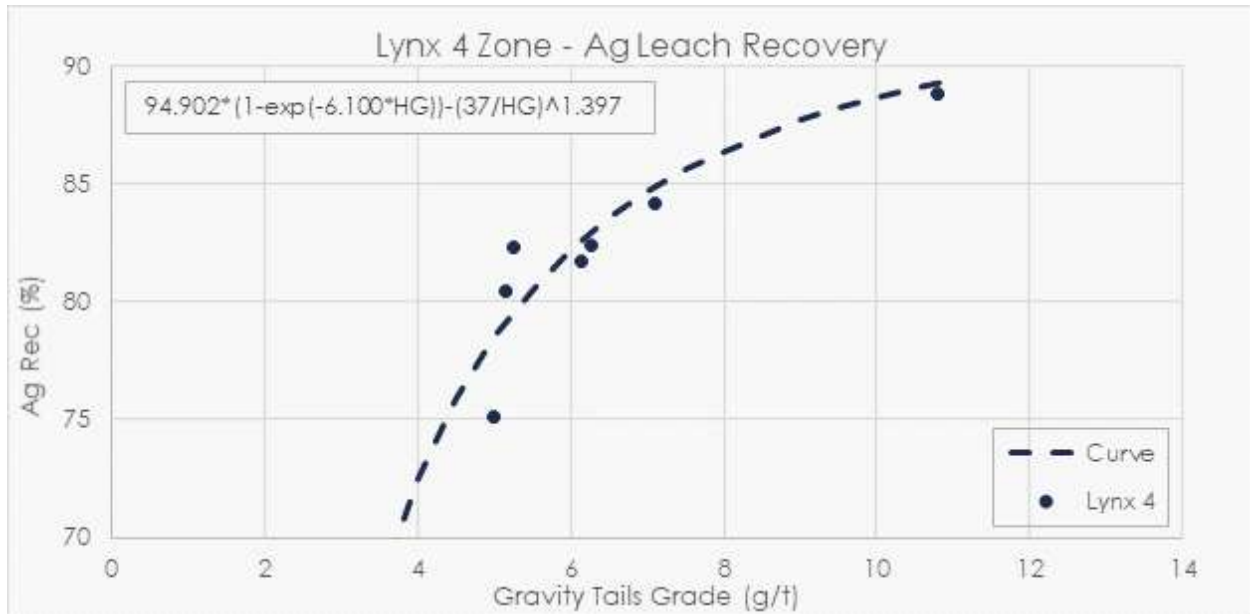

Figure 13-43: Lynx 4 zone silver recovery curve

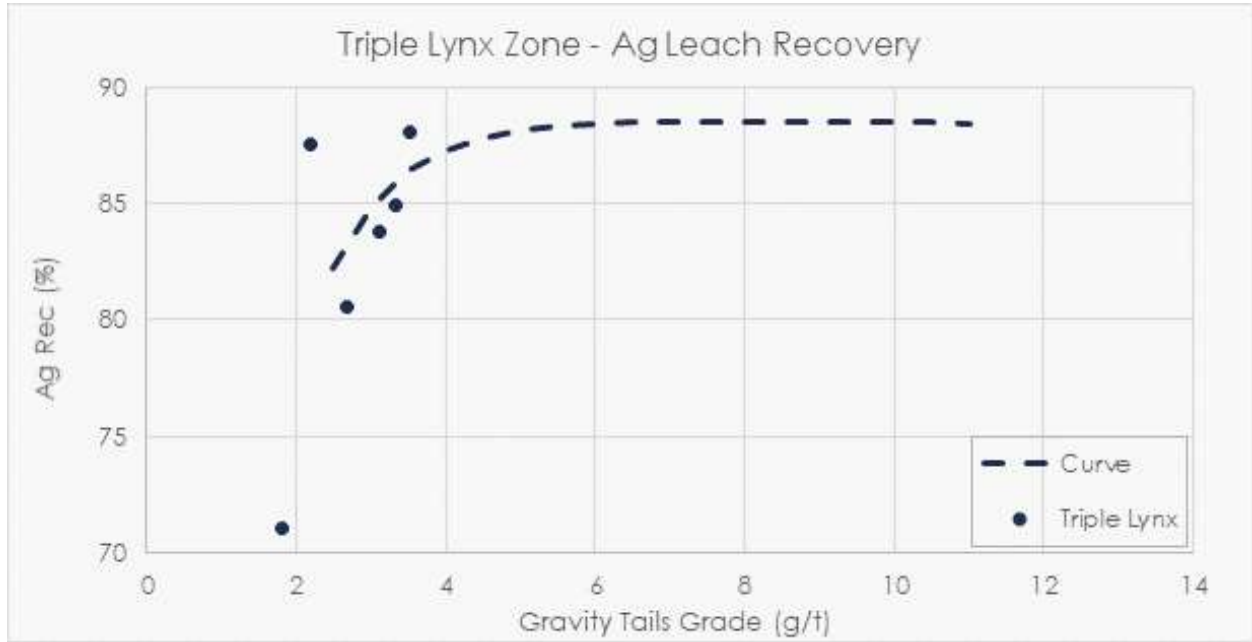

Figure 13-44: Triple Lynx zone silver recovery curve



14. Mineral Resource Estimates

The Mineral Resource Estimate presented herein (the “MRE”) was prepared by Osisko technical staff and reviewed and approved by the QP.

The QP, Pierre-Luc Richard, conducted an extensive review of the Datamine Studio RM projects. During these reviews, modelling, compositing and capping, block model coding, interpolation, classification, and reporting process were validated.

The MRE follows the “CIM Definition Standards - For Mineral Resources and Mineral Reserves” and the November 29, 2019 “CIM Estimation of Mineral Resources and Mineral Reserves Best Practice Guidelines”. The resource of the Windfall gold deposit includes the Lynx, Underdog, Main zone, and Triple 8 mineralized areas, which include several zones as presented in Table 14-1.

The resource area measures 3.0 km on strike, 1.7 km in width and is 1.6 km deep. However, excluding the Triple 8 zone, the resource area is 1.2 km deep.

The mineral resources reported herein are not mineral reserves and the economic viability of the resources has not been demonstrated. The MRE includes Measured, Indicated, and Inferred resources and is based on the assumption that the deposit will be potentially developed and mined using underground methods. The effective date of the estimate is June 7, 2022.

Since the effective date of this MRE, June 7, 2022, several activities related to the resources have taken place at the Windfall Project. The results of the activities mentioned below are not material to the Windfall MRE of June 7, 2022.

- As of October 10, 2022, a total of 164 drill holes were completed on the Windfall resource area totalling approximately 44,000 metres of drill core. Most of these drill holes, which are not included in the present MRE, are part of the ongoing underground drilling program. The program mainly targeted infill drilling of the mineralized lenses in the Lynx area.
- Exploration activities continues. This includes the extraction of the Triple Lynx bulk sample, as well as the extraction of other underground and stockpile materials. The material depleted includes ≈4 koz from the Triple Lynx bulk and a minor variation in the stockpiles (≈1 koz) noted as of September 1, 2022.
- Parts of the waste dump design, as proposed in this report, overlays the Mallard and Windfall North zones and will most probably decrease the future mineral resource by approximately 4 koz and 2 koz in the Indicated and Inferred resource categories respectively.

The previous MRE published on the Windfall Project was filed on February 10, 2022 (see Technical Report entitled “Mineral Resource Estimate Update for the Windfall Project, Eeyou Istchee James Bay, Québec, Canada”, effective date October 20, 2021) (Richard and Bélisle, 2022) and is available on SEDAR (www.sedar.com) under Osisko Mining Inc (“the previous MRE”).



14.1 Methodology

The MRE detailed in this report was prepared using Seequent Leapfrog Geo v.2021.2 (“Leapfrog”), Datamine Supervisor v.8.14 (“Supervisor”) and Datamine Studio RM v.1.11.300.0 (“Studio RM”) software. Leapfrog was used for modelling purposes, including the construction of 654 mineralization wireframes in Lynx, Underdog, Main zone, and Triple 8 areas. Studio RM was used for grade estimation and block modelling. Statistical studies were done using Supervisor and Microsoft Excel software.

The main steps in the methodology were as follows:

- Database compilation and validation of the DDH used in the mineral resource estimate;
- Modelling of mineralized lenses based on metal content, mineralization style, lithologies, alteration, and structural features;
- Generation of drill hole intercepts for each mineralized lens;
- Grade compositing;
- Capping studies on composited data;
- Spatial statistics;
- Grade interpolations;
- Validation of grade interpolations.

A block model was created for each of the following mineralized zones: 1) Lynx Main; 2) Lynx 4; 3) Lynx HW; 4) Triple Lynx (grouping Triple Lynx and Lynx SW); 5) Underdog; 6) Zone 27; 7) Caribou 1; 8) Caribou 2; 9) Caribou Extension; 10) Bobcat; 11) Mallard; 12) Windfall North; 13) F-Zones; and 14) Triple 8. The 14 block models were established in 14 Studio RM projects.

14.2 Drill Hole Database

The diamond drill hole (“DDH”) database of the Windfall Project contains 4,980 surface and underground drill holes, which corresponds to the holes completed at the Windfall Project as of June 7, 2022. The resource database excludes 146 drill holes as they were not located in the close vicinity of the main mineralized zones (see Chapters 6 and 10 for details on exploration and drilling activities). Figure 14-1 shows the 4,834 drill holes that were considered for the resource estimate, including 1,665,282 m in 4,152 drill holes (in red) drilled by Osisko.

The drill holes cover the strike length of the resource area at a drill spacing ranging from 12.5 m to 100 m and were drilled at variable orientations. The 4,834 resource drill holes represent 1,852,861 m of drill core.



The DDH database was closed at different times during the year as the drilling programs were completed in each zone. The series of dates, ending with the database closing on June 7, 2022, for the Lynx zones, is provided in Table 14-1. No significant drilling information was acquired in 2021-2022 in the Triple 8 zone; therefore, the database closing date of June 9, 2020, as used in the last two published MREs, is still in effect for this zone. Similarly, for Mallard, Bobcat, Caribou Extension and Caribou 1 zones, no significant drilling has been added in 2022; thus, the database closing dates for these zones remain the same as the previous MRE.

Regular validation routines are performed on the drilling database. Some additional verifications on the collar, down hole surveys and assay tables were executed prior to modelling and grade estimation.

Table 14-1: Mineralized zones included in areas reported in the MRE

Area	Zone	Database Closing Date
Lynx	Lynx Main	2022-06-07
	Triple Lynx	
	Lynx SW	
	Lynx 4	
	Lynx HW	2022-06-01
Underdog	Underdog	2022-05-02
Main Zone	Mallard	2021-09-01
	F-Zones	2022-05-02
	Bobcat	2021-05-17
	Caribou Extension	2021-10-20
	Zone 27	2022-05-02
	Caribou 1	2021-05-17
	Caribou 2	2022-02-25
	Windfall North	2022-01-20
Triple 8	Triple 8	2020-06-09

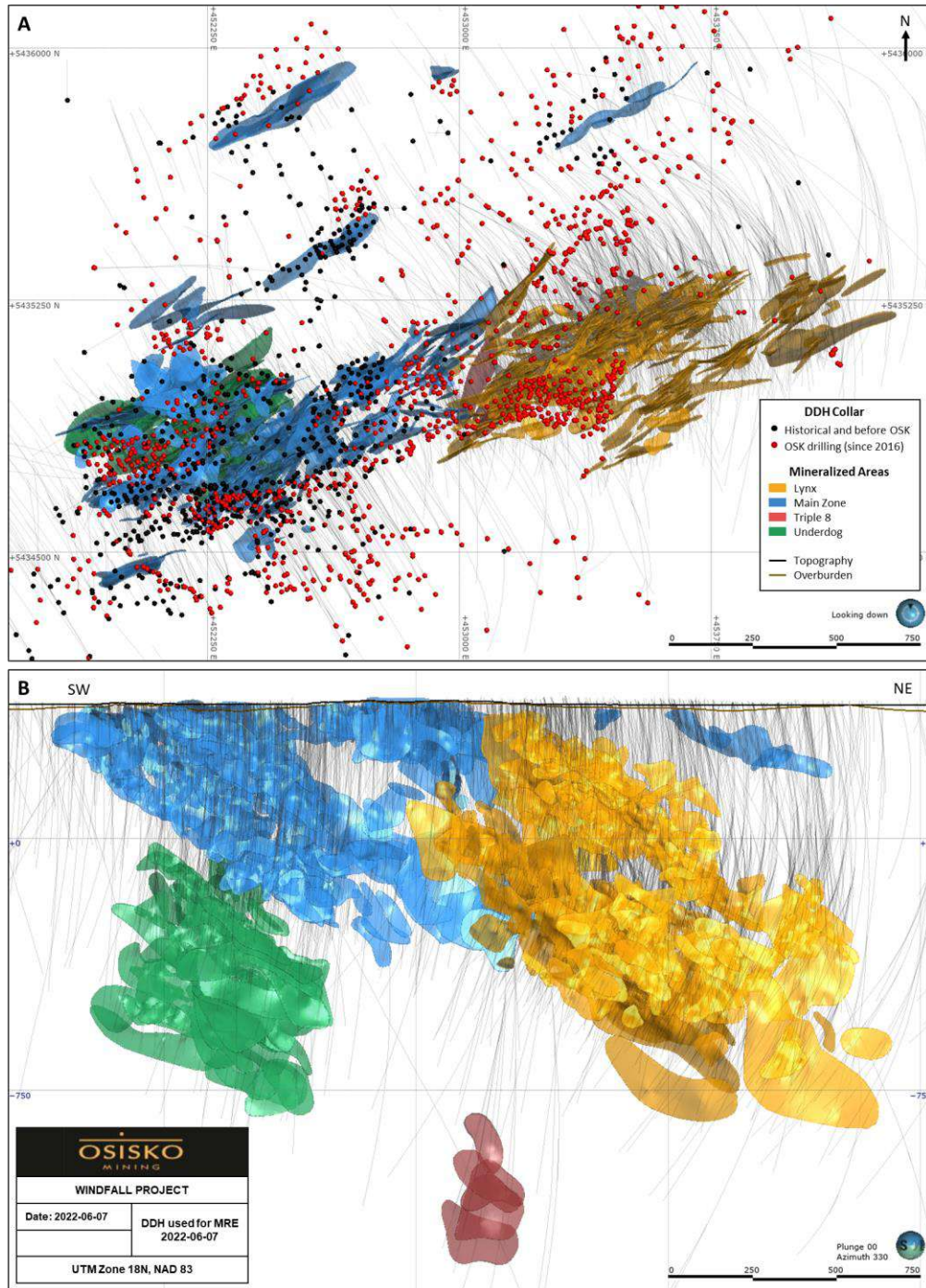

Figure 14-1: Diamond drill holes in the Windfall database used for the resource estimate
A) Plan view; and B) Longitudinal view (looking northwest)



14.3 Geological Model

The geological model was developed by the Windfall geological team. The main lithological units of the deposit presented in the model include a series of felsic to mafic dikes cross-cutting volcanic rocks. The geological model, as of June 2022, constitutes the basis for the interpretation of the mineralization. The Red Dog (I2F), the I13 and the I2J post-mineralization dikes (Figure 14-3) were included in the block models and were treated as barren units overprinting the mineralized lenses for the grade interpolation.

14.4 Interpretation of Mineralized Lenses

The interpretation of the geology and the mineralization of the Windfall deposit is supported by surface and underground infill drilling, underground mapping in the exploration ramp development and bulk sample results. The mineralization model is based on gold grade, mineralization style, lithologies, alteration and structural features. The estimation of silver grades was computed in the modelled gold lenses.

A total of 654 distinct mineralization solids were constructed. The details of the lenses modelled per zone is presented in Table 14-2. Note that the MRE reported herein is constrained by 579 gold-bearing individual wireframes. Different block modelling processes have contributed to the filtering of 75 lenses out of the reported resource, such as the selection of grade blocks above the cut-off grade, resource classification, and creation of mineable volumes.

Table 14-2: Number of mineralized envelopes modelled and reported per zone with their average thickness

Zone	Number of modelled lenses	Number of lenses reported in the resource	Average lens thickness (m)
Lynx Main	81	66	3.0
Triple Lynx	76	72	4.5
Lynx SW	18	18	3.8
Lynx 4	64	58	2.9
Lynx HW	25	25	2.9
Underdog	78	71	3.2
Zone 27	81	72	3.3
Caribou 1	57	45	3.4
Caribou 2	60	53	3.5
Caribou Extension	20	15	3.3



Zone	Number of modelled lenses	Number of lenses reported in the resource	Average lens thickness (m)
Bobcat	35	32	3.2
Mallard	37	33	3.1
Windfall North	6	5	2.8
F-Zones	11	9	2.9
Triple 8	5	5	5.6
Total	654	579	-

The 3D wireframing was generated in Leapfrog from hand-selected mineralized intervals on combined cross-sections and plan views. The wireframes are snapped to drill hole intercepts and have a minimum true thickness of 2.0 m to reflect the underground minimum mining width. The average thickness of the modelled lenses by zone is presented in Table 14-2.

Most mineralized envelopes are subvertical, striking northeast-southwest and plunging approximately 40° towards the northeast. Other mineralized domains, mainly located in the Underdog and the Main zone areas, are striking northeast-southwest, dipping 45° to the southeast and plunging between 40° and 60° towards the northeast.

The lens wireframes represent grade envelopes of continuous mineralization aiming at enclosing composite grades greater than 3.0 g/t Au over 2 m.

In the Triple Lynx zone, 24 lower grade wireframes surrounding the higher grade lenses were modelled based on a 5-m buffer around the high-grade lenses. Generally, these low-grade buffer lenses encompass composite grades greater than 0.5 g/t Au over 2 m. The low-grade domains were not reported in the MRE but will serve as a dilution envelope for mining studies.

The lateral extensions of the mineralized domains were limited by the shortest distance between 50 m from the last composite or half the distance to the next drill hole. A lens wireframe must be based on at least four drill holes that demonstrate 3D mineralization continuity.

Some isolated gold intercepts exist outside the interpreted mineralized envelopes. Those isolated values are not attributed to any lens given the lack of mineralization continuity.

Figure 14-2 and Figure 14-3, respectively, show the distribution of the 654 mineralized lenses within the four mineralized areas and their spatial and geometric relationship with the post-mineralization dikes (barren units).



The geological interpretation of the Lynx area is subdivided into five zones: Lynx Main, Lynx 4, Lynx HW, Lynx SW and Triple Lynx. The Main zone area is subdivided into eight zones: Zone 27, Caribou 1, Caribou 2, Bobcat, Caribou Extension, Mallard, Windfall North, and F-Zones. Figure 14-4 and Figure 14-5 show the location of the modelled areas.

The QP reviewed the geological model in 3D view, plan view and cross-section and is of the opinion that the level of detail to which the geology model was constructed represents adequately the complexity of the deposit. In the QP's opinion, the geological model is appropriate for the size, grade distribution and geometry of the mineralized lenses and is suitable for the resource estimation of the Windfall deposit.

14.5 Mined-out Voids Model

The 3D wireframe of the mined-out volumes, surveyed by Osisko as of June 6, 2022, intersects some of the mineralized lenses in the Main and Lynx areas (Figure 14-6). These volumes represent the ore drives, cross-cuts and stopes, and were coded in the block model as voids. No resources are reported inside the mined-out volumes.

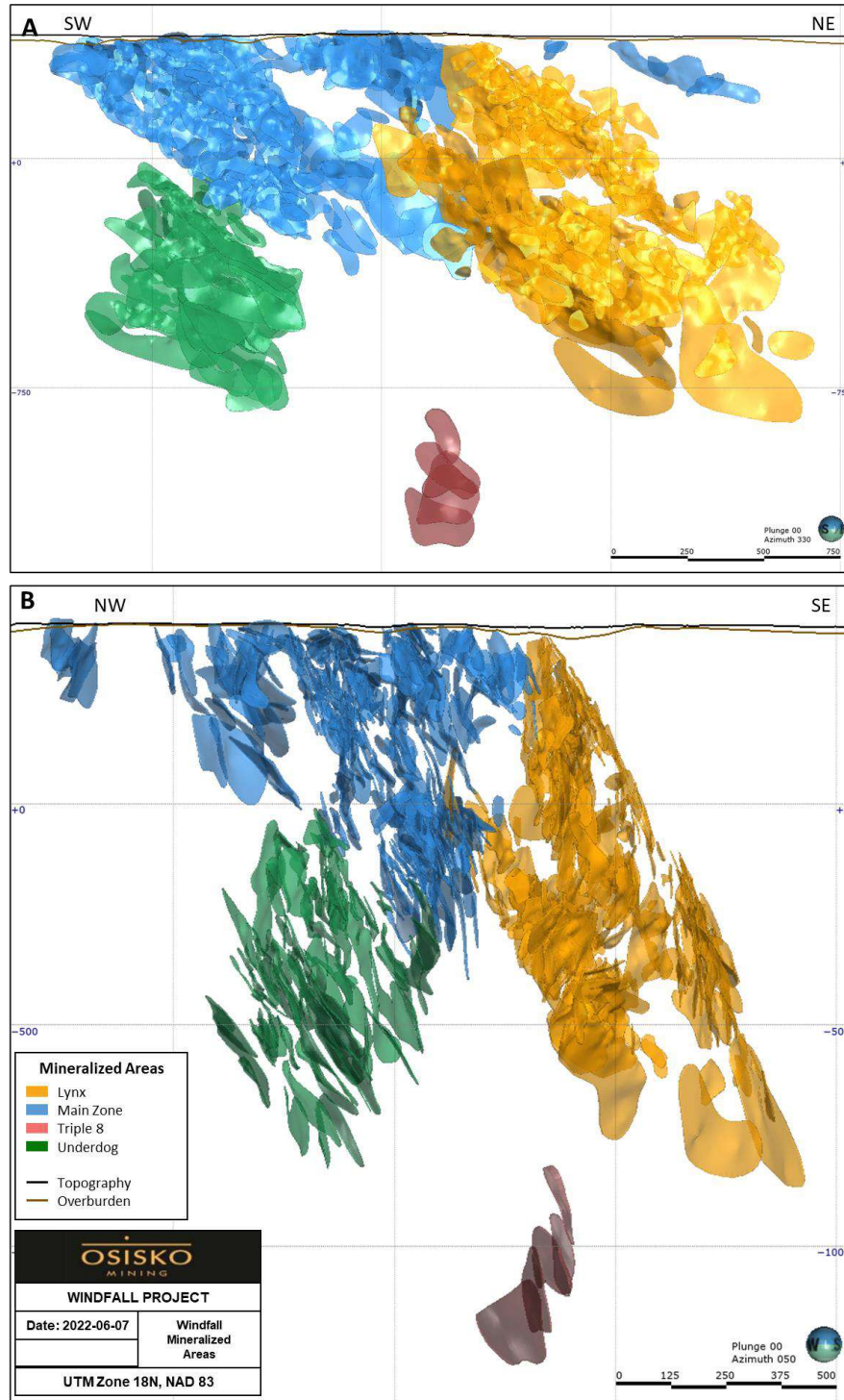

Figure 14-2: Mineralized domains modelled in the Windfall deposit
A) Longitudinal view (looking northwest); and B) Cross-section view (looking northeast)

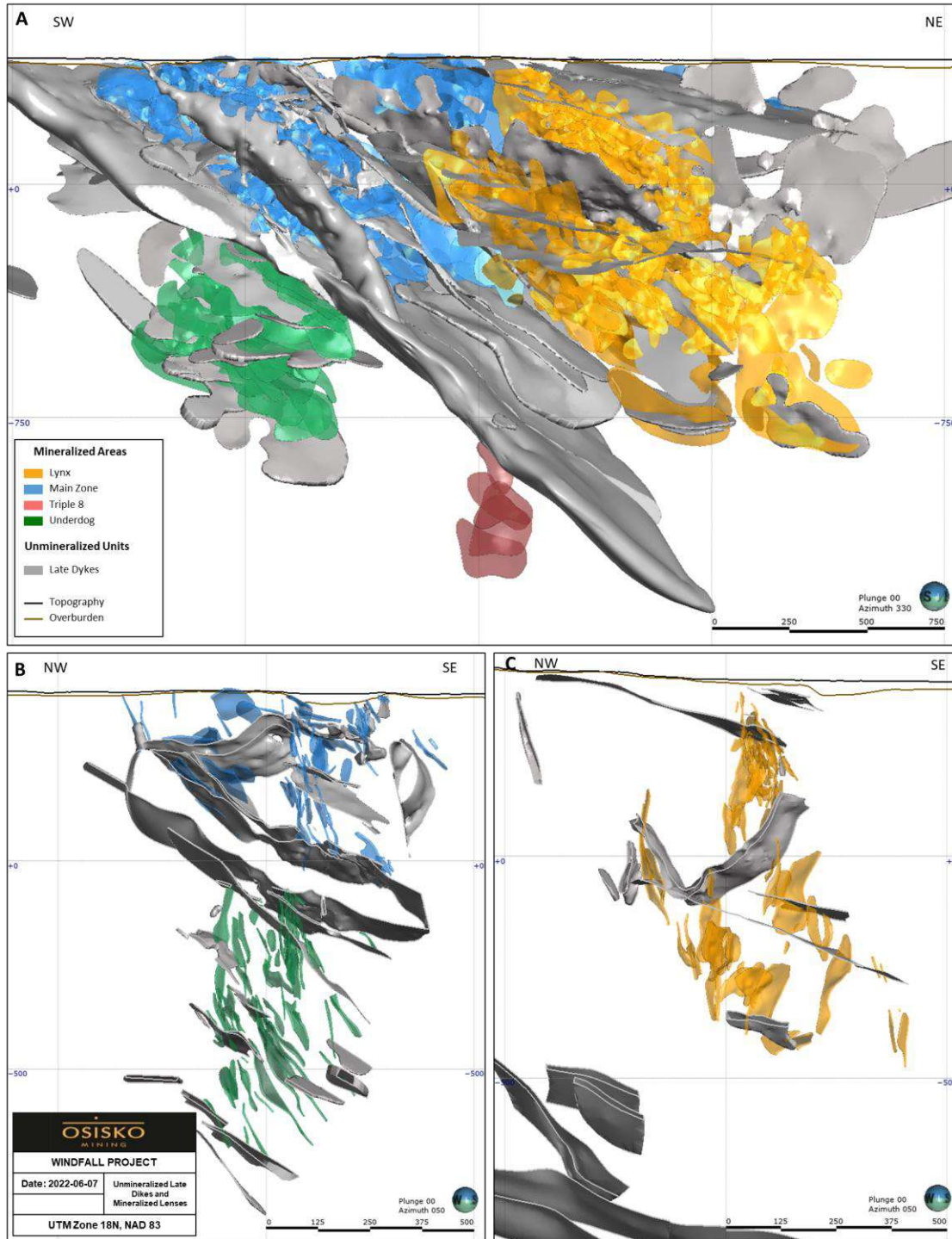

Figure 14-3: Unmineralized late dikes and modelled lenses in the Windfall deposit
A) Longitudinal view (looking northwest); B) Cross-section view of Main and Underdog zones (looking northeast); and C) Cross-section view of Lynx zones (looking northeast)

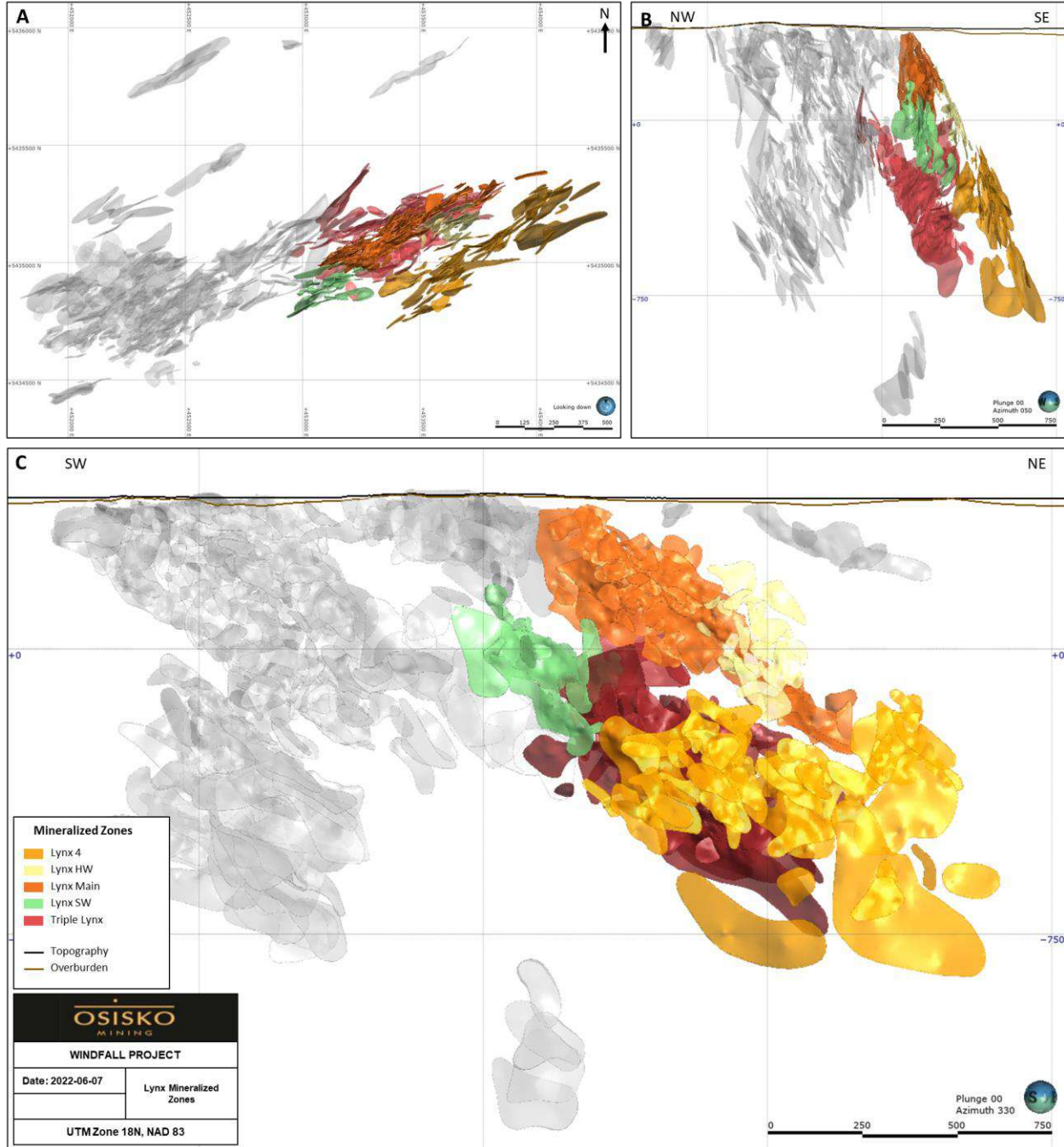

Figure 14-4: Lynx mineralized zones in the Windfall deposit
A) Plan view; B) Cross-section view (looking northeast); and C) Longitudinal view (looking northwest)

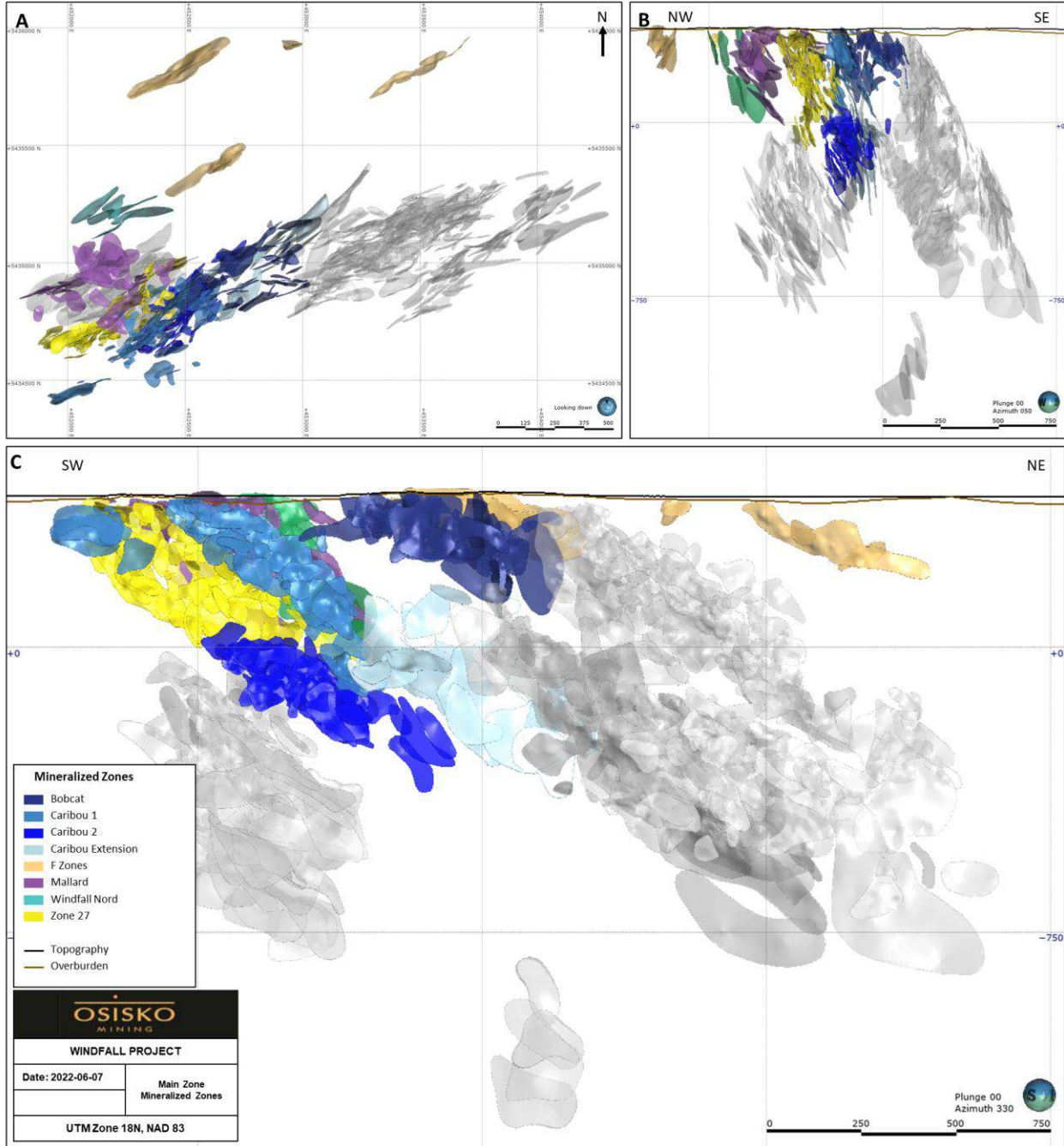

Figure 14-5: Main zone mineralized zones in the Windfall deposit
A) Plan view; B) Cross-section view (looking northeast); and C) Longitudinal view (looking northwest)

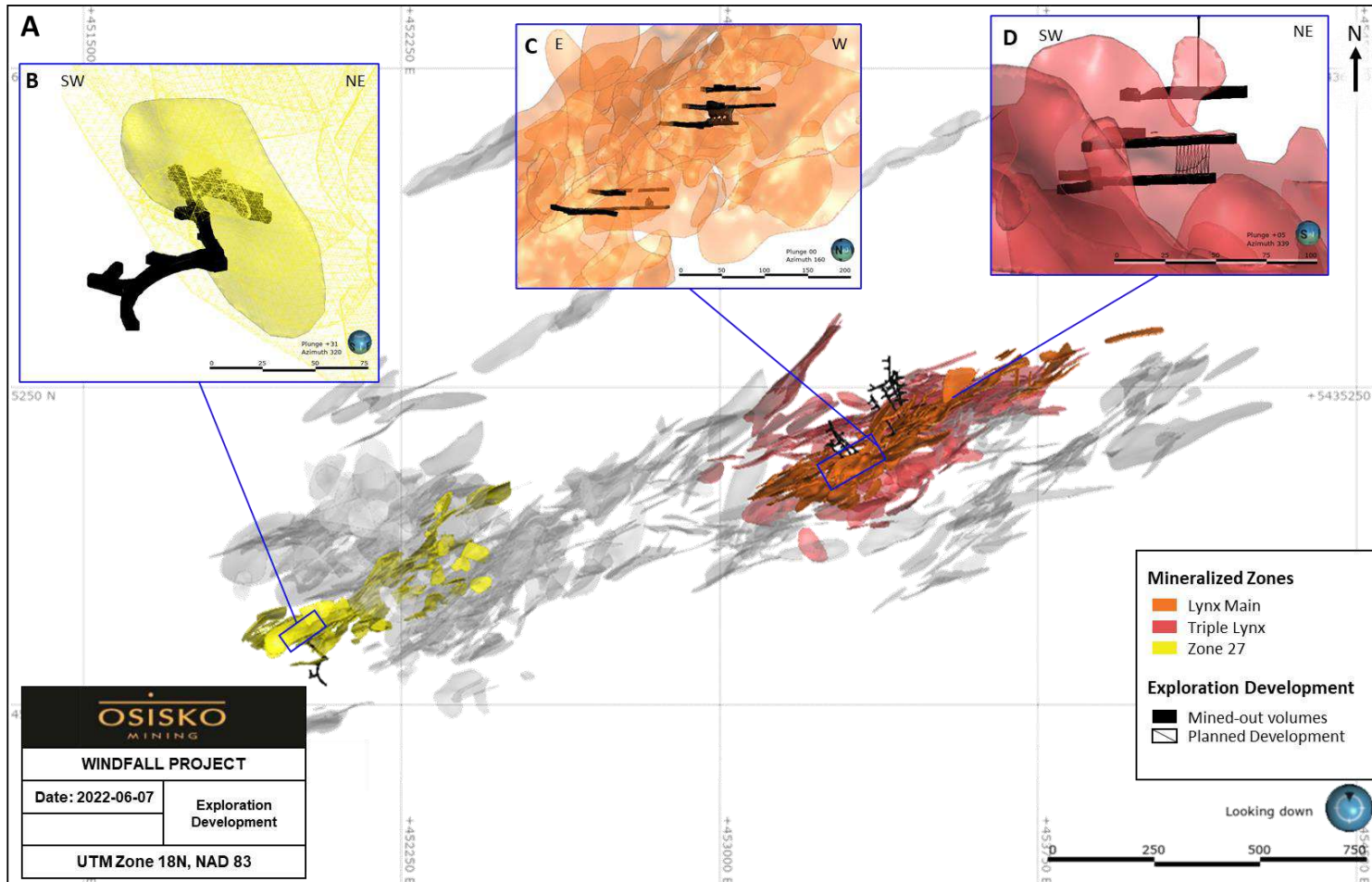

Figure 14-6: Exploration ramp intersecting mineralization of the Windfall deposit
A) Plan view; Underground mined-outs including bulk samples in: B) Zone 27; C) Lynx Main; and D) Triple Lynx



14.6 Compositing and High-grade Capping

Every drill hole interval intersecting a mineralized domain was attributed a lens code based on the name of the 3D solids. The coded intercepts were used to generate univariate statistics on sample lengths, gold and silver grades of raw assays. The results are presented in Table 14-3 and Table 14-4.

14.6.1 Compositing

To minimize any bias introduced by varying sample lengths, the gold and silver assays of the drill hole data were composited within each mineralized lens. The thickness of the mineralized domains, the proposed block size, and the average sample length were considered for the selected composite length.

Composites of 2.0 m (down hole) with distributed tails were generated inside the mineralized wireframes. If the last interval was shorter than 1.0 m (tails), composites' lengths were adjusted to keep all intervals equal. All intervals located within the mineralized lenses that were not sampled were given a value of $\frac{1}{4}$ the detection limit (0.00125 g/t Au and 0.0025 g/t Ag) during the compositing. Additionally, gold composites were discarded when they were located within a lens interval where pending or QA/QC failed assays were present. Silver composites were only discarded when they were located within a lens interval where pending assays were present. No QA/QC was performed for silver assays, but this is mitigated by the fact that silver is not material to the deposit.

A total of 17,918 gold composites were generated for the Lynx area, 2,789 for Underdog, 12,054 for Main zone and 130 for Triple 8 in the mineralized lenses.

Unlike gold assays, samples were not analyzed systematically for silver content. A value of $\frac{1}{4}$ the detection limit (0.0025 g/t Ag) was attributed to assays without silver analysis except for the Triple 8 zone where no replacement value was attributed. The drill hole database for the Triple 8 zone have not been updated for this MRE, and silver assay values remained unchanged.

A total of 17,910 silver composites were generated for the Lynx area, 2,789 for Underdog, 12,020 for Main zone and 71 for Triple 8 in the mineralized lenses.



14.6.2 High-grade Capping

High-grade capping values for gold and silver were applied on composite data using a three-step capping strategy where capping values decrease as interpolation search distances increase. The multiple capping strategy limits the influence of high-grade composites during interpolation over long ranges by using lower capping values.

High-grade capping values were established on a per lens basis or per group of lenses. The mineralized lenses were usually grouped by geographic location, geological characteristics, and/or by grade range to facilitate the statistical studies but were also examined individually. Generally, a set of capping grades was determined for higher grade lenses with a good mineralization continuity, and another set of capping values was defined for the group of lower grade lenses.

Table 14-3: Statistics on gold raw assays presented by zone

Zone	Number of lenses	Number of raw assays	Minimum (g/t Au)	Maximum (g/t Au)	Uncut mean (g/t Au)	Median (g/t Au)	Standard deviation	CV
Lynx Main	81	833,718	0.001	90,700.0	1.1	0.0	112.6	102.5
Triple Lynx	76	16,871	0.003	35,900.0	14.7	0.9	299.8	20.5
Lynx SW	18	2,697	0.005	1,475.0	6.8	0.3	44.4	6.5
Lynx 4	64	7,640	0.003	9,830.0	19.3	0.7	181.1	9.4
Lynx HW	25	1,843	0.003	1,220.0	9.6	0.6	54.4	5.7
Underdog	78	7,715	0.001	2,590.0	8.7	0.8	47.5	5.5
Zone 27	81	9,636	0.001	6,070.0	7.7	0.8	97.9	12.8
Caribou 1	57	5,636	0.001	4,070.0	3.5	0.6	55.6	15.7
Caribou 2	60	3,964	0.001	4,620.0	7.5	0.8	77.7	10.4
Caribou Extension	20	1,349	0.005	3,020.0	5.6	0.7	82.9	14.9
Bobcat	35	3,029	0.003	4,911.2	8.1	0.3	131.9	16.4
Mallard	37	2,782	0.001	5,550.0	5.9	0.3	115.6	19.6
Windfall North	6	768	0.001	1,725.0	6.1	0.2	68.8	11.3
F-Zones	11	1,369	0.001	504.5	4.2	0.4	17.0	4.1
Triple 8	5	354	0.005	278.0	5.5	1.3	17.3	3.2



Table 14-4: Statistics on silver raw assays presented by zone

Zone	Number of lenses	Number of raw assays	Minimum (g/t Ag)	Maximum (g/t Ag)	Uncut mean (g/t Ag)	Median (g/t Ag)	Standard deviation	CV
Lynx Main	81	848,672	0.003	4,710.0	0.5	0.0	13.3	28.5
Triple Lynx	76	11,482	0.005	1,430.0	5.4	1.0	29.2	5.4
Lynx SW	18	1,766	0.010	1,160.0	5.7	1.0	30.8	5.4
Lynx 4	64	7,752	0.003	4,710.0	11.2	0.6	82.0	7.3
Lynx HW	25	1,157	0.060	922.0	9.5	1.0	51.0	5.4
Underdog	78	7,733	0.003	427.0	3.0	1.0	9.4	3.1
Zone 27	81	9,764	0.003	956.0	3.7	1.0	16.9	4.6
Caribou 1	57	6,180	0.001	4,070.0	3.4	0.5	53.2	15.5
Caribou 2	60	4,061	0.003	690.0	4.0	1.0	15.5	3.9
Caribou Extension	20	1,349	0.003	791.0	4.3	0.9	23.5	5.5
Bobcat	35	3,029	0.003	534.0	3.5	0.3	16.8	4.8
Mallard	37	2,789	0.003	644.0	2.0	0.3	13.1	6.5
Windfall North	6	810	0.003	936.0	2.9	0.0	34.2	12.0
F-Zones	11	1,369	0.003	32.2	0.6	0.0	1.9	3.3
Triple 8	5	190	0.250	62.0	6.0	3.0	9.1	1.5

The series of capping values were defined by abnormal breaks or changes of slope on probability plots of grade distribution or by scattered points outside the main distribution curve (see examples illustrated in Figure 14-7).

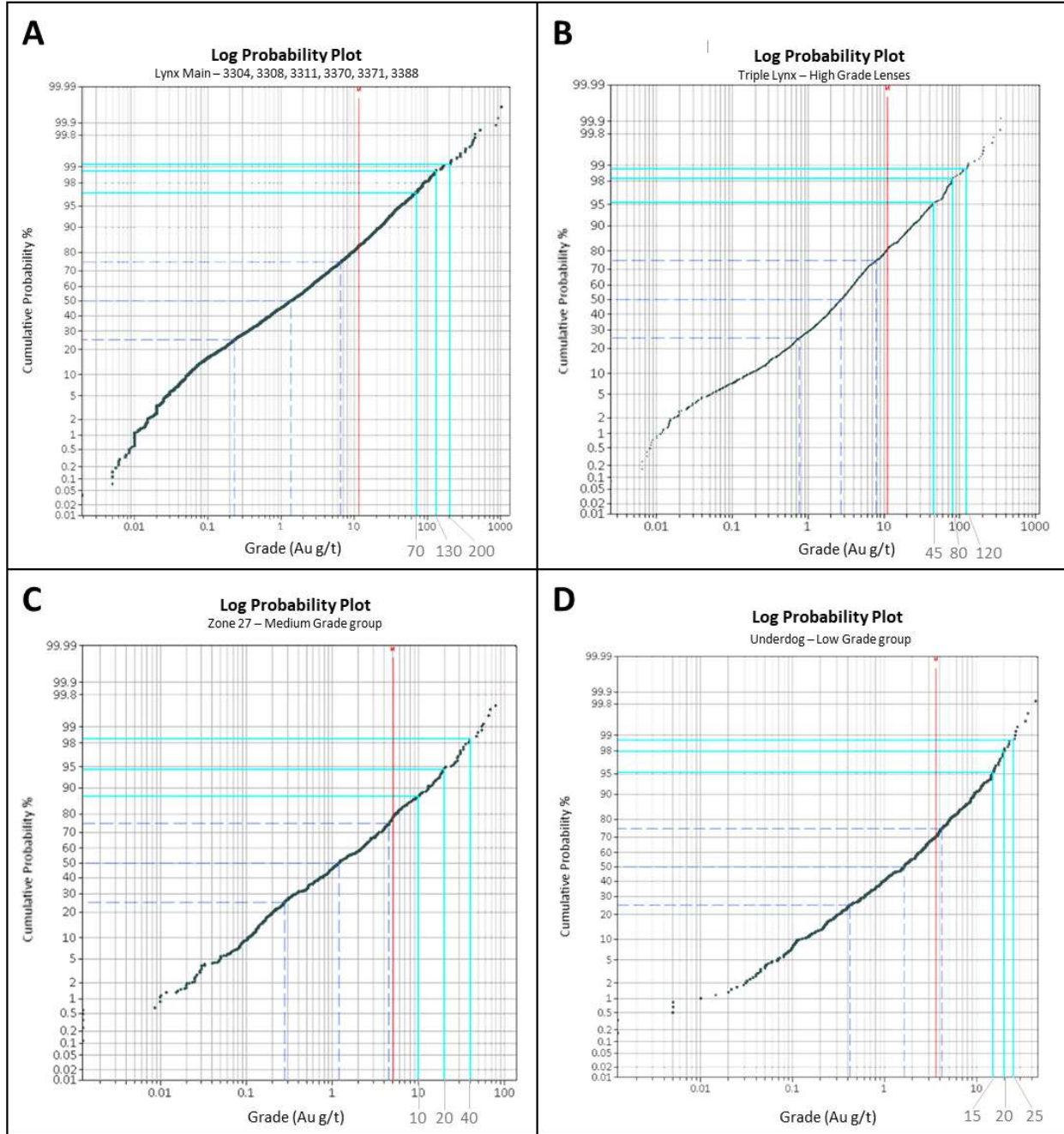

Figure 14-7: Examples of three-step gold grade capping on composites using a grade distribution probability plot
A) Lynx Main, high-grade lenses – Group 1; B) Triple Lynx zone, high-grade lenses; C) Lynx Hanging Wall, medium-grade lenses; and D) Underdog, low-grade lenses



The following criteria were also checked to validate the first capping value or to adjust it if needed:

- The log-normal distribution of grades must not show any erratic grade bins or distant values from the main population.
- The coefficient of variation must be approximately 2.0.

Table 14-5 and Table 14-6 present the selection of the capping limits used in the grade interpolation passes by group of lenses for each zone. A three-step capping strategy was used for all zones.

Table 14-7 and Table 14-8 present a summary of the statistical analysis of the composites for each mineralized zone. Note that the metal loss values appearing in this table represent an estimation based on the ratio of the sum of composites before and after capping. This estimation is not perfectly representative given the uneven drill spacing and inherent over-representation of extreme assay values in this type of metal loss estimation.

Table 14-5: Compilation of gold capping limits applied to composites, by interpolation pass

Zone	Group description	Capping (g/t Au)		
		Pass 1	Pass 2	Pass 3
Lynx Main	High-grade lenses - Group 1	200	130	70
	High-grade lenses - Group 2	110	75	50
	Medium-grade lenses - Group 1	60	30	20
	Medium-grade lenses - Group 2	50	30	15
	Low-grade lenses	25	25	10
Triple Lynx	Lens 3161	200	110	55
	High-grade lenses	120	80	45
	Medium-grade lenses - Consistent	85	55	40
	Medium-grade lenses - Diffuse	70	45	25
	Medium-grade lenses - Mix	50	25	10
	Low-grade lenses	25	15	10
	North of Lynx	20	15	10
Lynx SW	Diffuse grade lenses	50	35	15
	Mix grade lenses	30	20	10
Lynx HW	High-grade lenses	75	50	30
	Medium-grade lenses	50	30	15
	Low-grade lenses	20	15	10



Zone	Group description	Capping (g/t Au)		
		Pass 1	Pass 2	Pass 3
Lynx 4	High-grade lenses - Group 1	150	75	40
	High-grade lenses - Group 2	70	50	25
	Medium-grade lenses	50	30	15
	Low-grade lenses	25	15	10
Underdog	High-grade lenses	105	65	30
	Medium-grade lenses	60	45	25
	Low-grade lenses	25	20	15
Zone 27	High-grade lenses	85	50	35
	Medium-high-grade lenses	70	35	20
	Medium-grade lenses	40	20	10
	Low-grade lenses	25	20	10
Caribou 1	High-grade lenses	55	20	8
	Medium-grade lenses	25	12	6
	Low-grade lenses	-	6	6
Caribou 2	All lenses	55	27	15
Caribou Extension	All lenses	25	15	10
Bobcat	Group A: Central area	60	20	15
	Group B: Bank fault area	65	30	15
Mallard	High-grade lenses	50	25	15
	Medium-grade lenses	30	15	10
	Low-grade lenses	15	15	10
Windfall North	All lenses	50	20	10
F-Zones	High-grade lenses	50	25	10
	Other lenses	20	20	10
Triple 8	All lenses	55	25	15



Table 14-6: Compilation of silver capping limits applied to composites, by interpolation pass

Zone	Group description	Capping (g/t Ag)		
		Pass 1	Pass 2	Pass 3
Lynx Main	High-grade lenses	150	100	60
	Medium-grade lenses	60	30	10
	Low-grade lenses	25	25	10
Triple Lynx	High-grade lenses	120	50	25
	Medium-grade lenses	60	30	15
	Low-grade lenses	25	15	10
Lynx SW	All lenses	35	20	10
Lynx HW	High-grade lenses	85	35	15
	Medium-grade lenses	50	35	15
	Low-grade lenses	20	15	10
Lynx 4	High-grade lenses - Group 1	150	85	30
	High-grade lenses - Group 2	90	60	30
	Medium-grade lenses - Group 1	55	35	15
	Medium-grade lenses - Group 2	40	15	10
	Low-grade lenses	25	15	10
Underdog	All lenses	35	20	15
Zone 27	Lens 1115	55	40	25
	High & medium-grade lenses	45	30	20
	Low-grade lenses	15	10	10
Caribou 1	All lenses	45	20	10
Caribou 2	All lenses	30	20	15
Caribou Extension	All lenses	40	20	10
Bobcat	All lenses	45	25	15
Mallard	Lens 5211	50	25	10
	Medium-grade lenses	30	15	10
	Low-grade lenses	-	7	7
Windfall North	All lenses	10	10	5
F-Zones	All lenses	10	5	5
Triple 8	All lenses	-	20	15



Table 14-7: Summary statistics comparing the uncapped and capped gold composites, by zone

Zone	Number of lenses	Uncapped composite information						Capped composite information (based on first capping)				
		Number of composites	Minimum (g/t Au)	Maximum (g/t Au)	Mean (g/t Au)	Standard deviation	CV	Number of capped composites	Metal loss (%)	Mean (g/t Au)	Standard deviation	CV
Lynx Main	81	6,729	0.001	13,636.4	9.4	170.1	18.1	66	35%	6.1	18.2	3.0
Triple Lynx	76	6,517	0.001	1,104.6	8.1	33.6	4.2	83	16%	6.7	18.3	2.7
Lynx SW	18	1,030	0.005	319.1	5.1	17.8	3.5	15	21%	4.1	8.2	2.0
Lynx 4	64	2,918	0.010	3,179.1	18.8	101.7	5.4	93	41%	11.1	26.3	2.4
Lynx HW	25	724	0.008	613.3	7.5	29.7	4.0	19	26%	5.6	12.5	2.2
Underdog	78	2,789	0.001	382.6	6.5	18.1	2.8	33	10%	5.9	12.2	2.1
Zone 27	81	3,943	0.001	1,767.0	5.7	43.2	7.6	42	31%	3.9	9.2	2.3
Caribou 1	57	2,496	0.001	611.0	2.7	14.5	5.5	21	15%	2.3	5.0	2.2
Caribou 2	60	1,650	0.001	1,127.6	5.7	29.6	5.2	14	17%	4.7	8.4	1.8
Caribou Extension	20	546	0.012	605.1	3.9	26.3	6.7	5	31%	2.7	4.0	1.4
Bobcat	35	1,341	0.001	2,839.7	6.3	82.9	13.1	11	55%	2.9	7.7	2.6
Mallard	37	1,220	0.000	2,222.5	5.7	68.2	12.0	26	55%	2.6	6.1	2.3
Windfall North	6	260	0.001	431.9	4.6	30.2	6.5	4	50%	2.3	6.8	3.0
F-Zones	11	598	0.001	135.1	4.3	11.0	2.6	9	9%	3.8	8.0	2.1
Triple 8	5	130	0.026	86.7	5.5	10.8	2.0	1	5%	5.3	9.2	1.7



Table 14-8: Summary statistics comparing the uncapped and capped silver composites, by zone

Zone	Number of lenses	Uncapped composite information						Capped composite information (based on first capping)				
		Number of composites	Minimum (g/t Ag)	Maximum (g/t Ag)	Mean (g/t Ag)	Standard deviation	CV	Number of capped composites	Metal loss (%)	Mean (g/t Ag)	Standard deviation	CV
Lynx Main	81	6,727	0.003	485.1	4.3	16.3	3.8	26	7%	4.0	11.8	3.0
Triple Lynx	76	6,505	0.003	396.4	2.8	11.8	4.3	86	17%	2.3	6.9	3.0
Lynx SW	18	1,030	0.003	343.7	3.1	13.1	4.2	3	14%	2.7	6.0	2.2
Lynx 4	64	2,918	0.003	1,364.0	11.1	46.8	4.2	58	23%	8.5	23.3	2.7
Lynx HW	25	730	0.003	332.5	4.9	23.0	4.7	12	26%	3.6	11.0	3.0
Underdog	78	2,789	0.003	95.1	2.6	4.6	1.8	18	3%	2.5	3.9	1.6
Zone 27	81	3,951	0.003	369.3	3.6	10.7	3.0	31	8%	3.3	6.3	1.9
Caribou 1	57	2,452	0.003	181.8	3.0	8.1	2.7	13	6%	2.8	5.5	2.0
Caribou 2	60	1,650	0.003	137.8	3.5	7.9	2.3	30	9%	3.2	4.8	1.5
Caribou Extension	20	546	0.003	159.1	3.6	9.0	2.5	5	8%	3.3	5.8	1.8
Bobcat	35	1,341	0.003	185.0	3.1	10.7	3.5	16	12%	2.6	6.4	2.4
Mallard	37	1,222	0.003	131.9	2.0	7.6	3.9	8	15%	1.7	4.8	2.8
Windfall North	6	260	0.003	234.8	2.5	15.2	6.1	4	47%	1.3	2.6	2.0
F-Zones	11	598	0.003	14.4	0.6	1.5	2.5	1	1%	0.6	1.4	2.4
Triple 8	5	71	0.250	27.5	6.0	6.4	1.1	0	-	-	-	-



14.7 Density

Densities are used to calculate tonnages for the estimated volumes derived from the resource-grade block model.

Fixed density values were applied in the block model (Table 14-9). The values implemented for late dikes and host rocks were based on a study on specific gravity ("SG") measurements completed in July 2021. This study consisted of 11,404 density measurements where most SG measurements were determined by the pycnometer method on pulps by ALS Minerals in Val-d'Or and Bureau Veritas in Timmins. The results are presented in Table 14-10.

The statistics for the material included in the mineralized lenses were based on raw SG assay data available at the closure of the database on June 7, 2022. A summary of the statistics is presented by zone in Table 14-11. Table 14-12 shows the median values of SG assay data integrated in the resource estimate for each zone. The selected values correspond to SG median values drawn from a representative group of matching rock type. In cases where insufficient samples (<25) were available to indicate the density of the lithology within the mineralized lens, the median density value of all lithologies within the mineralized lenses of the zone was used.

A density of 2.0 g/cm³ was assigned to the overburden.

Table 14-9: Density compilation for rock types coded in the block models

Rock type	Rock code	Density (g/cm ³)
Above topography	0	-
Ramp	5	-
Overburden	10	2.00
Late dikes	80-83	2.70-2.83
Lenses	>1,000, <9,000	2.74-2.93
Host rocks	> 20,000	2.72-2.85



Table 14-10: Statistics on specific gravity by rock type

Lithology	Number	Minimum	Maximum	Mean	Median	Standard deviation	CV
Late Dikes							
REDDOG	4,760	2.45	3.08	2.71	2.71	0.09	0.03
I13	1,453	2.48	3.13	2.70	2.70	0.08	0.03
I2J	837	2.56	3.17	2.84	2.83	0.10	0.04
Host Rocks							
I1 Frg	1,554	2.46	3.28	2.78	2.78	0.08	0.03
I1P	25,878	2.45	3.50	2.77	2.76	0.10	0.04
I1P	25,878	2.45	3.50	2.77	2.76	0.10	0.04
I1P YB	3,482	2.45	3.48	2.73	2.72	0.09	0.03
I2P	26,786	2.46	3.50	2.77	2.77	0.10	0.04
V1	25,854	2.46	3.48	2.77	2.76	0.10	0.04
I2 BIZ	261	2.55	3.08	2.77	2.78	0.09	0.03
I2-I3	12,151	2.45	3.50	2.82	2.81	0.11	0.04
V2-V3-V4	40,468	2.46	3.50	2.86	2.85	0.11	0.04
I4	741	2.57	3.29	2.82	2.82	0.11	0.04
S	27	2.60	2.92	2.76	2.76	0.10	0.04
Breccia	925	2.48	3.22	2.80	2.79	0.10	0.04

Table 14-11: Statistics on specific gravity assay results located inside mineralized lenses, by zone

Zone	Number	Minimum	Maximum	Mean	Median	Standard deviation	CV
Lynx Main	1 891	2.47	3.29	2.80	2.80	0.10	0.04
Triple Lynx-Lynx SW	1 083	2.55	3.35	2.80	2.79	0.09	0.03
Lynx 4	702	2.60	3.29	2.81	2.79	0.10	0.04
Lynx HW	138	2.52	3.12	2.79	2.79	0.10	0.03
Underdog	1 706	2.48	3.48	2.82	2.81	0.13	0.05
Zone 27	2 116	2.50	3.50	2.86	2.84	0.14	0.05
Caribou 1	1 712	2.47	3.50	2.83	2.81	0.14	0.05
Caribou 2	749	2.47	3.48	2.86	2.85	0.14	0.05
Caribou Extension	291	2.56	3.34	2.86	2.84	0.14	0.05
Bobcat	291	2.56	3.34	2.86	2.84	0.14	0.05
Mallard	375	2.53	3.43	2.85	2.83	0.15	0.05
Windfall North	23	2.66	3.17	2.97	2.98	0.14	0.05
F-Zones	201	2.68	3.30	2.87	2.87	0.03	0.01
Triple 8	96	2.64	3.40	2.95	2.93	0.17	0.06



Table 14-12: Median lithology values of specific gravity assay results located inside mineralized lenses, by zone

Zone	I1P	I1P YB	I2P	I1 FRG	S6	I3A	I4	V1	V2	ALL ⁽¹⁾
Lynx Main	2.77	-	-	2.79	-	2.86	-	2.77	2.89	2.80
Triple Lynx - Lynx SW	2.78	-	-	-	-	2.87	-	2.77	-	2.79
Lynx 4	2.78	-	-	-	-	2.88	-	2.77	2.80	2.79
Lynx HW	-	-	-	-	-	2.90	-	2.74	-	2.79
Underdog	2.77	2.77	2.81	2.79	-	-	-	2.75	2.91	2.81
Zone 27	2.83	-	2.83	-	-	2.91	-	2.79	2.91	2.84
Caribou 1	2.80	-	2.81	-	-	2.91	-	2.79	2.90	2.81
Caribou 2	2.78	-	2.82	-	-	2.88	-	-	2.88	2.85
Caribou Extension	2.80	-	2.83	-	-	-	-	2.81	2.90	2.84
Bobcat	2.80	-	2.83	-	-	-	-	2.81	2.90	2.84
Mallard	2.81	-	2.81	-	-	2.90	-	2.80	2.93	2.83
Windfall North ⁽²⁾	-	-	-	-	-	-	-	-	-	2.81
F-Zones	2.85	-	-	-	-	-	-	-	2.88	2.87
Triple 8 ⁽³⁾	-	-	-	-	-	-	-	-	-	2.80

⁽¹⁾ Median of all SG values within lenses of Project: value was used in cases where population of SG assay results within a lithology unit is less than 25.

⁽²⁾ Windfall North project has not enough SG data available, therefore the median value of lenses in all lithologies in Windfall was used (2.81).

⁽³⁾ Triple 8 project was not updated since the February 2021 MRE. An SG of 2.80 was used for its lenses.

14.8 Block Model

A block model was created for each of the following zones: 1) Lynx Main; 2) Lynx 4; 3) Lynx HW; 4) Triple Lynx (grouping Triple Lynx and Lynx SW); 5) Underdog; 6) Zone 27; 7) Caribou 1; 8) Caribou 2; 9) Caribou Extension; 10) Bobcat; 11) Mallard; 12) Windfall North; 13) F-Zones; and 14) Triple 8.

The block models are not rotated. Parent block cells have dimensions of 5 m long (X-axis) by 2 m wide (Y-axis) by 5 m vertical (Z-axis). The block dimensions were chosen to reflect the sizes of the mineralized lenses and plausible underground mining methods.

Table 14-13 presents the properties of the block models. Figure 14-8 shows the geographical distribution of the block models in the Windfall Project.



Table 14-13: Block models properties by zone

Zone	Properties	X (Column)	Y (Row)	Z (Level)
Lynx Main	Origin coordinates	453,000.00	5,434,900.00	-400.00
	Number of blocks	220	275	170
	Block extent (m)	1,100	550	850
	Block size (m)	5	2	5
Triple Lynx Lynx SW	Origin coordinates	452,800.00	5,434,600.00	-800.00
	Number of blocks	250	450	210
	Block extent (m)	1 250	900	1 050
	Block size (m)	5	2	5
Lynx 4	Origin coordinates	453,300.00	5,434,700.00	-900.00
	Number of blocks	205	340	165
	Block extent (m)	1 025	680	825
	Block size (m)	5	2	5
Lynx HW	Origin coordinates	453,470.00	5 435,040.00	-200.00
	Number of blocks	60	120	90
	Block extent (m)	300	240	450
	Block size (m)	5	2	5
Underdog	Origin coordinates	451,800.00	5,434,600.00	-850.00
	Number of blocks	165	295	170
	Block extent (m)	825	590	850
	Block size (m)	5	2	5
Zone 27	Origin coordinates	451,800.00	5,434,500.00	-200.00
	Number of blocks	170	325	140
	Block extent (m)	850	650	700
	Block size (m)	5	2	5
Caribou 1	Origin coordinates	451,850.00	5,434,350.00	-200.00
	Number of blocks	180	350	130
	Block extent (m)	900	700	650
	Block size (m)	5	2	5
Caribou 2	Origin coordinates	452,150.00	5,434,500.00	-400.00
	Number of blocks	140	325	100
	Block extent (m)	700	650	500
	Block size (m)	5	2	5



Zone	Properties	X (Column)	Y (Row)	Z (Level)
Caribou Extension	Origin coordinates	452,500.00	5,434,700.00	-450.00
	Number of blocks	130	326	140
	Block extent (m)	650	652	700
	Block size (m)	5	2	5
Bobcat	Origin coordinates	452,450.00	5,434,750.00	50.00
	Number of blocks	121	236	80
	Block extent (m)	605	472	400
	Block size (m)	5	2	5
Mallard	Origin coordinates	451,780.00	5,434,680.00	-30.00
	Number of blocks	160	230	92
	Block extent (m)	800	460	460
	Block size (m)	5	2	5
Windfall North	Origin coordinates	451,950.00	5,435,050.00	-50.00
	Number of blocks	111	151	111
	Block extent (m)	555	302	555
	Block size (m)	5	2	5
F-Zones	Origin coordinates	452,200.00	5,435,250.00	150.00
	Number of blocks	310	380	60
	Block extent (m)	1 550	760	300
	Block size (m)	5	2	5
Triple 8	Origin coordinates	452,950.00	5,434,800.00	-1 300.00
	Number of blocks	60	200	110
	Block extent (m)	300	400	550
	Block size (m)	5	2	5

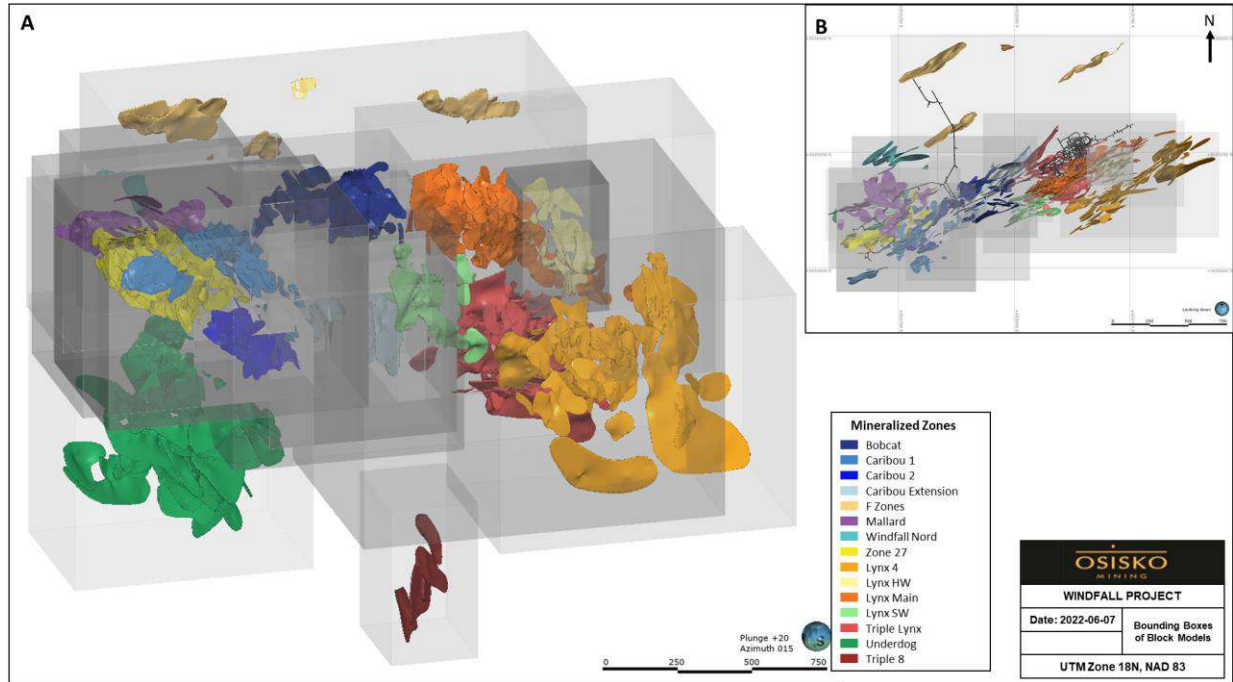

Figure 14-8: Bounding boxes of the block models
A) 3D view; and B) Plan view

14.9 Rock Coding and Sub-Celling

Parent blocks were divided into sub-cells when they intersected wireframes of mineralized lenses and post-mineralization dikes. A resolution of 4 in each axis direction was used in the division of the parent cells. Subsequently, the minimum sub-cell size is of 1.25 m long (X-axis) by 0.5 m wide (Y-axis) by 1.25 m vertical (Z-axis).

The rock coding sequence is as follows: 1) lithologies other than post-mineralization dikes; 2) mineralized envelopes; 3) post-mineralization dikes; 4) overburden; 5) topography; and 6) mined-out volumes. Overlapping solids were handled by priority ranking where the last stated wireframe overprints the previous wireframes in the list. The list of rock codes integrated in the block models is presented in the Table 14-14.



Table 14-14: Rock codes identified in the block models

Resource Area	Wireframes	Rock Codes (or series)
All	Ramp	5
	Overburden	10
	Late dikes	80-81-82-83
Lynx	Lynx Main	3300
	Triple Lynx (high-grade)	3100
	Lynx SW	3500
	Lynx 4	3400
	Lynx HW	3200
Main Zone	Zone 27	1000
	Caribou 1	2100
	Caribou 2	2200
	Caribou Extension	2500
	Bobcat	2300
	Mallard	5000
	F-Zones	6000
Windfall North	7000	
Underdog	Underdog	4000
Triple 8	Triple 8	8000



14.10 Variography and Search Ellipsoids

14.10.1 Variography

Three-dimensional (“3D”) directional variography was performed on the 2.0 m gold grade capped composites on major mineralized lenses (containing more than 300 composites) and/or geographical or orientation groups of lenses in each zone. The studies were carried out using Supervisor software. The overall approach to model the variography is described below:

- Examination of the strike and dip of the mineralized lenses to determine the axes of better continuity.
- Estimation of the nugget effect (C_0) based on the down hole variogram.
- Modelling of the major, semi-major and minor axes of continuity using spherical models.

Due to the variability of the grades within the mineralized lenses, the moderately-high nugget effect, and the lack of information in some lenses or groups of lenses, it was decided to refer to the variography analysis based on the most representative lens or group of lenses in each zone. The parameters of the variogram models are presented in Table 14-15. Figure 14-9 shows an example of the variography study in Lynx Main for major high-grade lenses of the zone.



Table 14-15: Variogram model parameters selected for each zone

Zone	Group description	Number of lenses	Variography components									
			Nugget	Model type	First structure			Second structure				
					Sill	Range X (m)	Range Y (m)	Range Z (m)	Sill	Range X (m)	Range Y (m)	Range Z (m)
Lynx Main	Major HG Lens	4	0.40	Spherical	0.30	20	10	5	0.30	60	25	15
	NE	51	0.60	Spherical	0.10	10	10	5	0.30	40	25	15
	NS	14	0.35	Spherical	0.30	5	5	5	0.35	30	15	10
	Bank	12	0.60	Spherical	0.20	15	5	5	0.20	30	15	10
Triple Lynx	Lens 3161	1	0.60	Spherical	0.25	25	20	10	0.15	40	25	15
	High-grade lenses	5	0.60	Spherical	0.25	25	20	10	0.15	40	25	15
	Other lenses	70	0.50	Spherical	0.50	30	20	15	-	-	-	-
Lynx SW	All lenses	18	0.65	Spherical	0.35	40	25	15	-	-	-	-
Lynx 4	All lenses	64	0.50	Spherical	0.50	30	20	10	-	-	-	-
Lynx HW	All lenses	25	0.60	Spherical	0.30	25	15	10	0.10	40	25	15
Underdog	All lenses	78	0.60	Spherical	0.40	40	25	15	-	-	-	-
Zone 27	All lenses	81	0.50	Spherical	0.50	25	20	15	-	-	-	-
Caribou 1	All lenses	57	0.55	Spherical	0.45	40	20	10	-	-	-	-
Caribou 2	All lenses	60	0.60	Spherical	0.40	40	20	15	-	-	-	-
Caribou Extension	All lenses	20	0.75	Spherical	0.25	45	30	15	-	-	-	-
Bobcat	Group A	7	0.50	Spherical	0.50	20	15	15	-	-	-	-
	Group B	19	0.50	Spherical	0.50	25	15	15	-	-	-	-
	Group C	9	0.50	Spherical	0.50	25	20	15	-	-	-	-
Mallard	All lenses	37	0.30	Spherical	0.70	30	20	15	-	-	-	-
Windfall North	All lenses	6	0.50	Spherical	0.50	35	25	10	-	-	-	-
F-Zones	All lenses	11	0.60	Spherical	0.40	30	20	15	-	-	-	-
Triple 8	All lenses	5	0.20	Spherical	0.80	60	40	20	-	-	-	-



The down hole variograms suggest nugget effects varying between 40% and 60% for most of the mineralized lenses in Lynx, Underdog and Main zone areas. Lower nugget effects varying from 20% to 30% were observed in Triple 8 and Mallard of the Main zone area, and higher nugget effects were observed in Caribou Extension (75%).

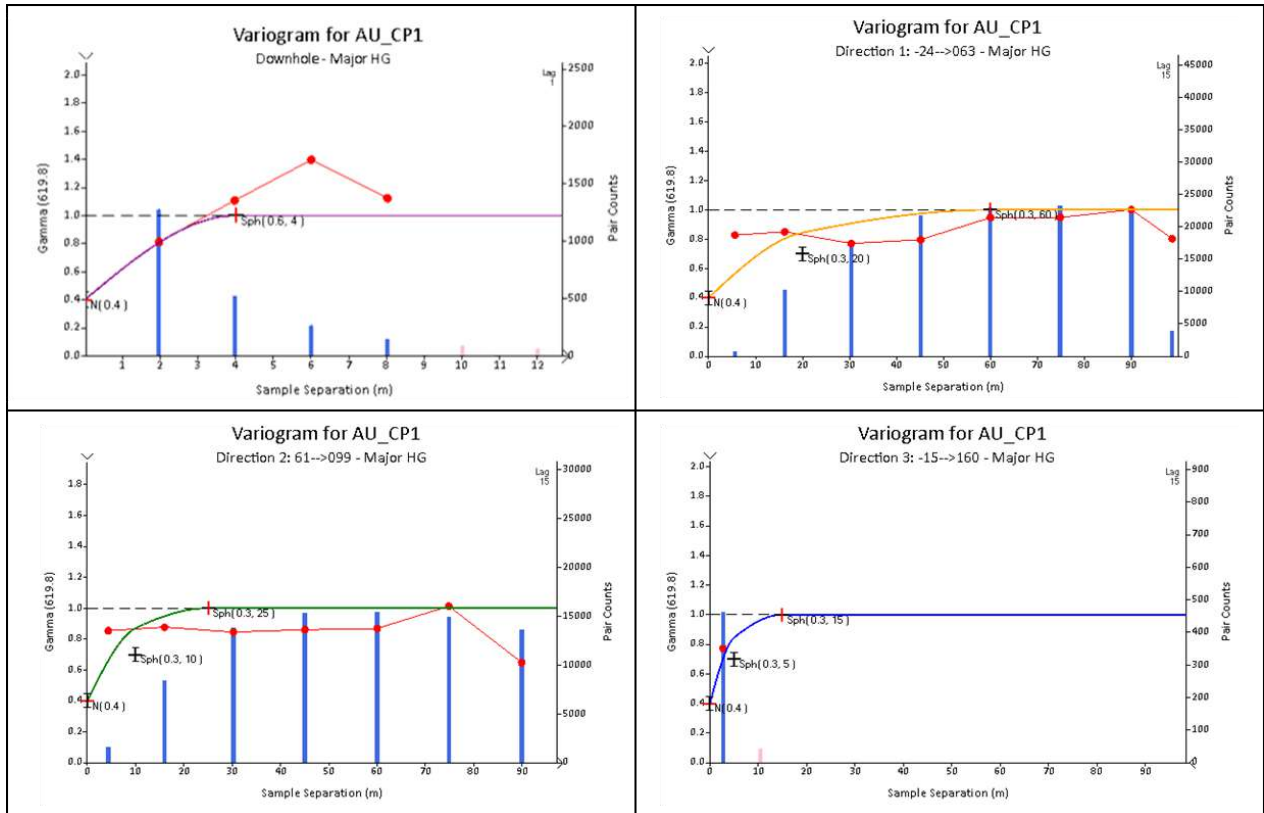

Figure 14-9: Example of variogram model in the Lynx Main zone – Major high-grade lenses



14.10.2 Search Ellipsoids

The search ellipsoids were oriented dynamically so that the strike and dip follow the undulations of the mineralized wireframes. The strike and dip data information were collected through Leapfrog software from the orientations of the triangles of each of the mineralized meshes. The direction of the mineralization plunge was determined for each lens from observations based on longitudinal views showing mineralization trends. Although occasionally isotropic, the trends are mainly varying from 30 to 60 degrees to the northeast. The plunge data and a declustered version of the Leapfrog structural data information was then stored into each block located inside a lens, using a nearest neighbour interpolation. For the grade interpolation, the search ellipsoid orientation was set according to the strike, dip and plunge data stored in each block. Figure 14-10 illustrates an example of the dynamic anisotropy configuration of the search ellipsoids in Lynx 4.

The ellipsoid ranges were based on the variography study. The grade interpolation is a three-pass process, cumulatively defining grade blocks through each pass. The ranges of the ellipsoids for the first interpolation pass correspond to 0.5x to 1x the variography range results, 0.75x to 2x the variography results for the second pass, and 3x to 5x the variography results for the third pass.

The search ellipsoids were built using the anisotropy ratio determined from the best fit variogram model in each group of lenses. Where the mineralization plunge was not apparent, isotropic ranges in the first and second directions were used in the search, e.g., a search of 25 m by 25 m by 15 m was used for lenses with no discernable trend plunge in Zone 27 in the first interpolation pass.

Table 14-16 summarizes the parameters of the ellipsoids used for each interpolation pass.

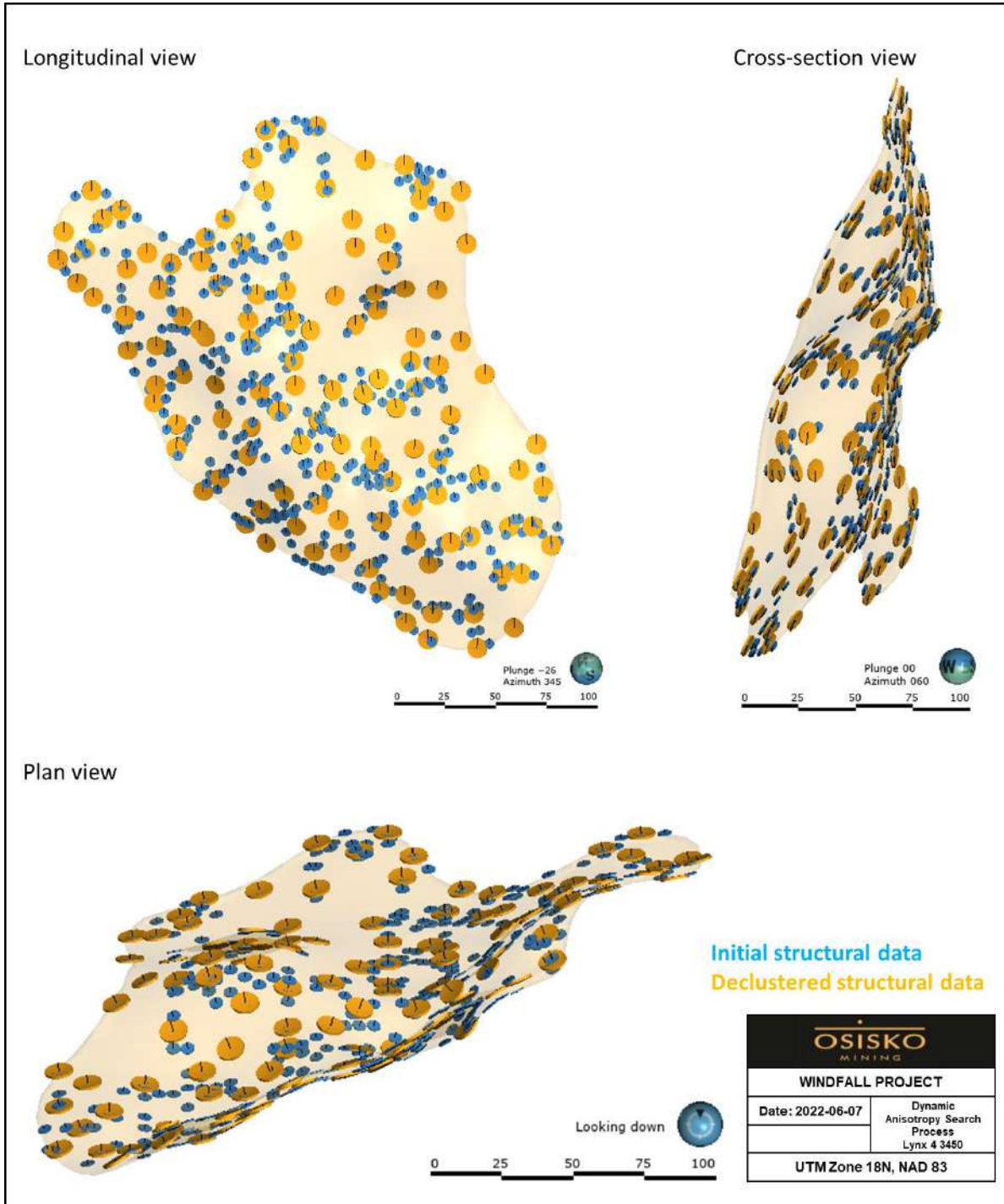

Figure 14-10: Example of the structural data collected through Leapfrog on lens 3450, Lynx 4, and used for the dynamic anisotropy search process



Table 14-16: Search ellipsoid ranges defined by interpolation pass

Zone	Group description	# of lenses	Pass 1				Pass 2				Pass 3			
			Vario multiplier	X (m)	Y (m)	Z (m)	Vario multiplier	X (m)	Y (m)	Z (m)	Vario multiplier	X (m)	Y (m)	Z (m)
Lynx Main	Major HG Vario	4	0.5	30	12.50	7.5	0.75	45	18.75	11.25	3	180	75	45
	NE Vario – HG group	8	0.5	20	12.50	7.50	0.75	30	19	11	3	120	75	45
	NE Vario – Other groups	43	0.75	30	18.75	11.25	1	40	25	15	3	120	75	45
	NS & Bank Vario – HG groups	6	0.5	15	7.50	5.00	0.75	23	11	8	3	90	45	30
	NS & Bank Vario – Other groups	20	0.75	23	11.30	8	1	30	15	10	3	90	45	30
Triple Lynx	Lens 3161	1	0.5	20	12.50	7.5	0.75	30	18.75	11.25	3	120	75	45
	High-grade lenses	5	0.75	30	18.75	11.25	1.5	60	37.5	22.5	3	120	75	45
	Other lenses	70	1	30	20.00	15	1.5	45	30	22.5	3	90	60	45
Lynx SW	All lenses	18	0.75	30	18.75	11.25	1	40	25	15	3	120	75	45
Lynx 4	All lenses	64	1	30	20.00	10	2	60	40	20	4	120	80	40
Lynx HW	All lenses	25	0.625	25	15.625	9.375	1.25	50	31.25	18.75	3	120	75	45
Underdog	All lenses	78	0.75	30	18.75	11.25	1.5	60	37.5	22.5	3	120	75	45
Zone 27	All lenses	81	1	25	20.00	15	2	50	40	30	3	75	60	45
Caribou 1	All lenses	57	0.75	30	15.00	7.5	1.25	50	25	12.5	3	120	60	30
Caribou 2	All lenses	60	1	40	20.00	15	1.5	60	30	22.5	3	120	60	45
Caribou Extension	All lenses	20	1	45	30	15	1.5	67.5	45	22.5	3	135	90	45
Bobcat	Group A	7	1	20	15	15	2	40	30	30	5	100	75	75
	Group B	19	1	25	20	15	3	75	60	45	5	125	100	75
	Group C	9	1	25	20	15	3	75	60	45	5	125	100	75
Mallard	All lenses	37	1	30	20	15	1.5	45	30	22.5	3	90	60	45
Windfall North	All lenses	6	1	35	25	10	2	70	50	20	3	105	75	30
F-Zones	All lenses	11	1	30	20	15	2	60	40	30	3	90	60	45
Triple 8	All lenses	5	0.75	45	45	15	1.5	90	90	30	3	180	180	60



14.11 Grade Interpolation

The parameters for interpolating the gold and silver grade models were derived from the variography study based on the capped gold composites. The interpolations were executed on sets of points providing the locations X, Y, Z, the lens code, and grade extracted from the 2.0 m capped composites for gold and silver.

The composite points were assigned lens codes corresponding to the mineralized lens in which they occur. The interpolation profiles correlate to a unique composite lens code, thus establishing hard boundaries between the lenses. Blocks are estimated using composite points associated with the same lens.

The Ordinary Kriging ("OK") method was selected for the resource estimate of gold for all zones of the Windfall deposit. The Inverse Distance Square ("ID2") method was used for the estimation of the silver in all zones.

As described above, a three-step capping process was used on composites to limit unreasonable estimation of very high-grade composites. The first interpolation pass used composites where the highest capping value was applied, and subsequent passes used lower capping limits on composites. For example, in Lynx 4, for High-grade lenses - Group 1, gold composites were capped at: 1) 150 g/t Au; 2) 75 g/t Au; and 3) 40 g/t Au and were respectively used in interpolation passes 1 to 3 (refer to Table 14-5 and Table 14-6 for capping limits).

The interpolations were run in successive passes characterized by increasing search ranges and varying minimum number of composites (Table 14-16 and Table 14-17). Three interpolation passes were applied. The first pass used a relatively small radius search ellipsoid to interpolate the mineralization blocks located in the close vicinity of the drill holes. The second pass interpolated the blocks that were not interpolated during the previous pass. The third pass was defined to populate the remaining blocks within the mineralization solids.

Figure 14-11 and Figure 14-12 illustrate examples of grade distribution on typical cross-section and longitudinal views.



Table 14-17: Composite search specifications by interpolation pass

Zone	Group description	Number of lenses	Composite number						Maximum number of composites per drill hole
			Pass 1		Pass 2		Pass 3		
			Minimum	Maximum	Minimum	Maximum	Minimum	Maximum	
Lynx Main	Major HG Vario	4	9	12	7	12	5	12	2
	NE Vario – HG group	8	7	12	5	12	3	12	2
	NE Vario – Other groups	43	5	12	3	12	3	12	2
	NS & Bank Vario - HG Groups	6	7	12	5	12	3	12	2
	NS & Bank Vario – Other groups	20	5	12	3	12	3	12	2
Triple Lynx	All lenses	76	3	12	3	12	3	12	2
Lynx SW	All lenses	18	3	12	3	12	3	12	2
Lynx 4	All lenses	64	3	12	3	12	3	12	2
Lynx HW	All lenses	25	3	12	3	12	3	12	2
Underdog	All lenses	78	3	12	3	12	3	12	2
Zone 27	All lenses	81	3	12	3	12	3	12	2
Caribou 1	All lenses	57	5	12	3	12	3	12	2
Caribou 2	All lenses	60	3	12	3	12	3	12	2
Caribou Extension	All lenses	20	5	12	3	12	3	12	2
Bobcat	All lenses	35	3	12	3	12	3	12	2
Mallard	All lenses	37	3	12	3	12	3	12	2
Windfall North	All lenses	6	5	12	3	12	3	12	2
F-Zones	All lenses	11	5	12	3	12	3	12	2
Triple 8	All lenses	5	5	12	3	12	3	12	2

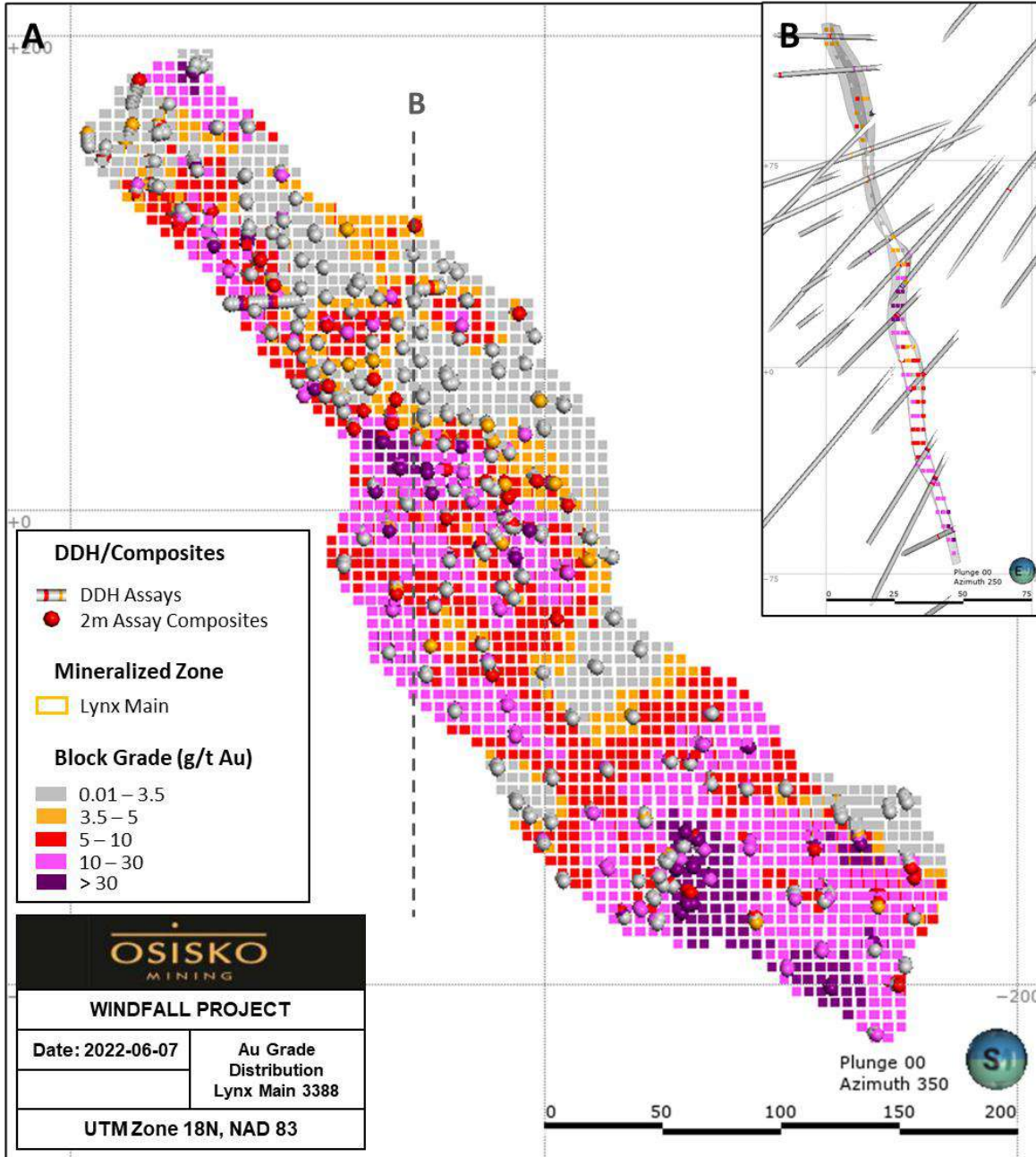

Figure 14-11: Gold grade distribution in mineralized lens 3388, Lynx Main zone
A) Longitudinal view looking N-NW - the dashed line shows the location of the cross-section; and
B) Cross-section looking NE (slicer thickness: 10 m)

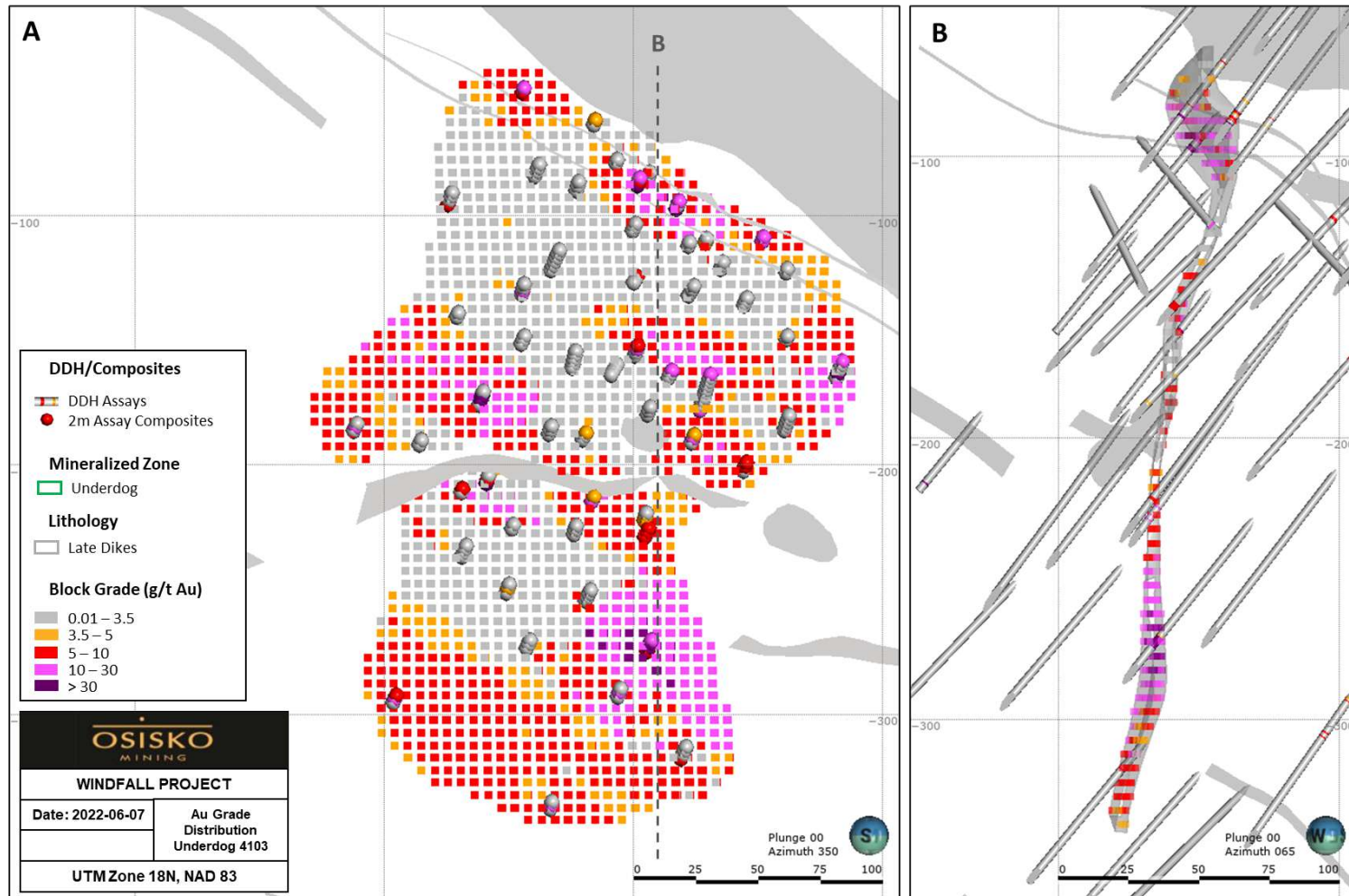

Figure 14-12: Gold grade distribution in mineralized lens 4103, Underdog area

A) Longitudinal view looking N-NW - the dashed line shows the location of the cross-section; and B) Cross-section looking NE (slicer thickness 20 m)



14.12 Block Model Validation

14.12.1 Volume Validation

A comparison between the volumes of wireframe lenses and volumes of lenses in the block model was performed to validate the rock coding of mineralized envelopes. The difference in volume was non-significant (less than +/- 0.3%) for all lenses.

14.12.2 Visual Validation

A visual comparison between block model grades, composite grades, and assay grades was conducted on sections, plans, and longitudinal views for both densely and sparsely drilled areas. No significant differences were observed during the comparison, and in general, a good match in grade distribution without excessive smoothing in the block model was observed.

Visual comparisons were also conducted between OK, ID2 and Nearest Neighbour ("NN") gold interpolation scenarios. The ordinary kriging scenarios selected for the gold estimations, produced a block grade distribution representative of the mineralization style observed in the deposit.

14.12.3 Statistical Validation

Table 14-18 compares the gold mean grade of the blocks (including all classified blocks weighted on their volume inside a mineralized lens) using a zero cut-off grade within the composite grades of each mineralized lens. The comparison was done using the composite grades capped at the highest capping value (i.e., first pass capping limit).

The comparison between composite and block grade distributions did not identify significant issues. As expected, the block grades are generally lower than the composite grades. Slightly higher grades are observed in estimated blocks versus composites in the cases of Lynx HW and Zone 27. The higher density of drill holes intercepting lower grade areas and the angle of the DDH (locally subparallel to the lenses in Lynx HW) explains the difference between the mean grades.



Table 14-18: Comparison of the block and composite mean grades at a zero cut-off grade for blocks of all resource classes

Zone	Number of composites	Composite (g/t Au)	Number of blocks	OK Grade model (g/t Au)	ID2 Grade model (g/t Au)	NN Grade model (g/t Au)
Lynx Main	6,729	6.1	368,835	5.6	5.6	5.5
Triple Lynx	6,517	6.7	774,353	5.7	5.7	5.7
Lynx SW	1,030	4.1	160,777	3.6	3.6	3.8
Lynx 4	2,918	11.1	506,236	11.0	11.0	10.6
Lynx HW	724	5.6	81,549	6.2	6.1	5.9
Underdog	2,789	5.9	912,599	5.0	5.1	5.3
Zone 27	3,943	3.9	316,007	4.0	4.0	4.1
Caribou 1	2,496	2.3	265,000	2.0	2.0	2.1
Caribou 2	1,650	4.7	258,370	4.7	4.7	4.6
Caribou Extension	546	2.7	214,297	2.6	2.6	2.8
Bobcat	1,341	2.9	207,120	2.8	2.8	3.0
Mallard	1,220	2.6	226,184	2.3	2.4	2.4
Windfall North	260	2.3	88,794	1.6	1.6	1.5
F-Zones	598	3.8	215,432	3.2	3.2	3.3
Triple 8	130	5.3	70,914	3.5	3.6	4.1

Figure 14-13 illustrates the cross-section swath plots for gold to compare the block model grades to the composite grades for each major zone. In general, the model correctly reflects the trends shown by the composites, with the expected smoothing effect.

Based on visual and statistical reviews, it is the QP's opinion that the Windfall block models provide a reasonable estimate of in situ gold resources.

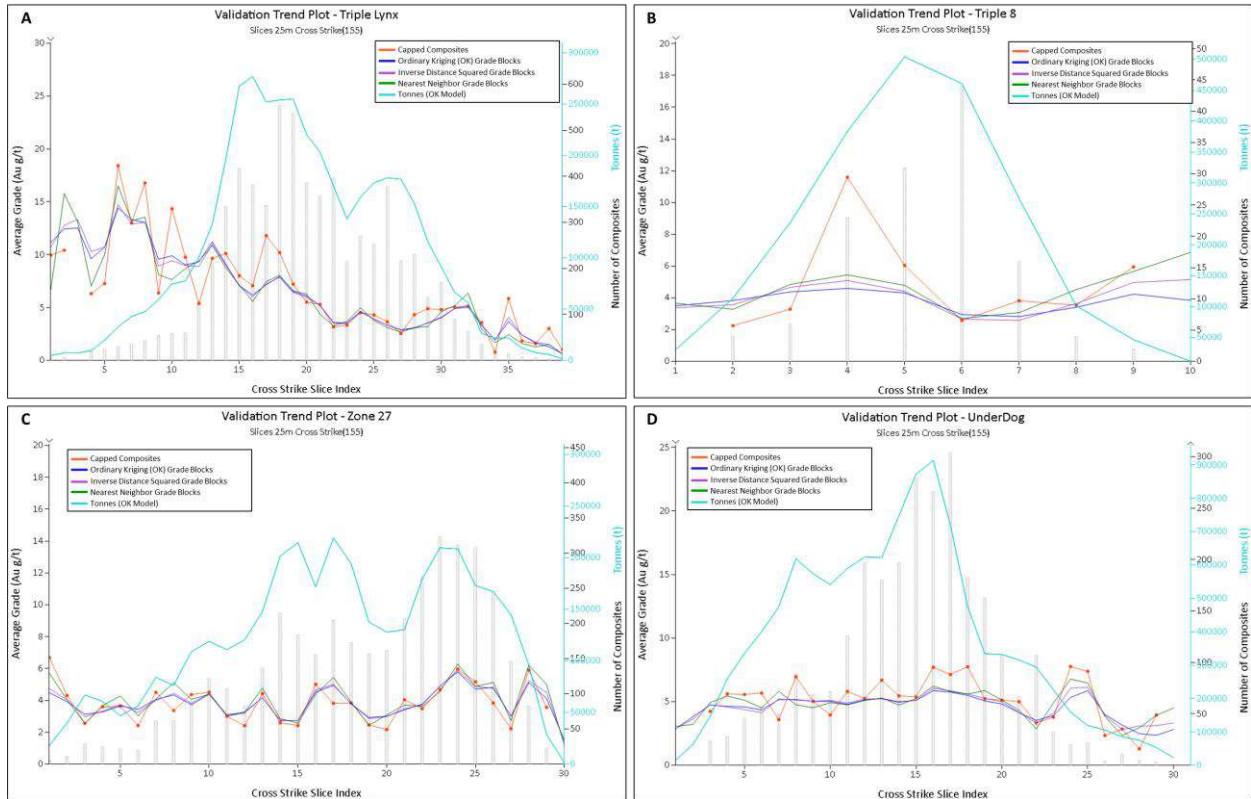

Figure 14-13: Cross-section swath plots by mineralization zone
A) Triple Lynx; B) Triple 8; C) Zone 27; and D) Underdog

14.13 Cut-off Parameters

According to CIM's best practice guidelines (2019), the cut-off grade should consider the following (CIM, 2019):

- Reasonable long-term commodity price(s);
- Assumed mining methods;
- Exchange rate(s);
- Mineral process recovery; and
- Operating costs relating to mining, processing, general and administration, smelter terms, and royalties, among others.

Additional considerations include deposit location and scale, geologic and grade continuity, environmental and social considerations, and waste disposal costs.



In addition, according to the CIM best practice guideline (2019), “variations of rock characteristics, metallurgy, mining methods, processing methods, etc. within the mineral resource model may necessitate more than one cut-off grade or economic limit for different parts of the deposit”.

The selected cut-off grade of 3.5 g/t Au was used to determine the mineral potential of the deposit and report the mineral resources. The underground cut-off grade (“UCoG”) was determined based on the parameters presented in Table 14-19. The cut-off calculation has been rounded up to 3.5 g/t Au.

Since the previous MRE, changes have been made to parameter calculations that can account for changes in the various costs. The mining cost was revised to account for market inflation as well as increases in maintenance, manpower, and equipment costs. The tailings filtration plant, previously accounted for in the environment cost, is now under the processing cost. Gold price and exchange rates were established using the three-year moving average method.

It should be noted that all parameters are either based on similar projects or reasonable technical and economic factors. The QP of this report section believes that the calculated cut-off grades and the parameters used are relevant for a mineral resource estimate, as they are relevant to the grade distribution of the project and that the mineralization exhibits sufficient continuity. However, these parameters must be re-evaluated in future studies and, subsequently, could change.

Table 14-19: Parameters used to estimate the UCoG for the MRE

Parameters	Unit	Value
Gold Price	USD/oz	1,600
Exchange Rate	USD/CAD	1.28
Mill Recovery	%	93
Payability	%	99.95
Sell Cost	USD/oz	5
Royalties (NSR)	%	2
Mining Cost	\$/T milled	125
G&A Cost	\$/T milled	39
Processing Cost	\$/T milled	42
Environment	\$/T milled	4
Calculated Cut-off Grade	g/t Au	3.51
MRE Cut-off Grade	g/t Au	3.5



14.14 Mineral Resource Classification

14.14.1 Mineral Resource Classification Definition

The resource classification definitions used for this report are those published by the Canadian Institute of Mining, Metallurgy and Petroleum in their documents “CIM Definition Standards - For Mineral Resources and Mineral Reserves” and “CIM Estimation of Mineral Resources and Mineral Reserves Best Practice Guidelines” published on May 10, 2014, and November 2019, respectively.

The definitions are as follow:

Inferred Mineral Resource

- An Inferred Mineral Resource is that part of a Mineral Resource for which quantity and grade or quality are estimated on the basis of limited geological evidence and sampling. Geological evidence is sufficient to imply but not verify geological and grade or quality continuity.
- An Inferred Mineral Resource has a lower level of confidence than that applying to an Indicated Mineral Resource and must not be converted to a Mineral Reserve. It is reasonably expected that the majority of Inferred Mineral Resources could be upgraded to Indicated Mineral Resources with continued exploration.

Indicated Mineral Resource

- An Indicated Mineral Resource is that part of a Mineral Resource for which quantity, grade or quality, densities, shape, and physical characteristics are estimated with sufficient confidence to allow the application of Modifying Factors in sufficient detail to support mine planning and evaluation of the economic viability of the deposit.
- Geological evidence is derived from adequately detailed and reliable exploration, sampling and testing and is sufficient to assume geological and grade or quality continuity between points of observation.
- An Indicated Mineral Resource has a lower level of confidence than that applying to a Measured Mineral Resource and may only be converted to a Probable Mineral Reserve.

Measured Mineral Resource

- A Measured Mineral Resource is that part of a Mineral Resource for which quantity, grade or quality, densities, shape, and physical characteristics are estimated with confidence sufficient to allow the application of Modifying Factors to support detailed mine planning and final evaluation of the economic viability of the deposit.



- Geological evidence is derived from detailed and reliable exploration, sampling and testing and is sufficient to confirm geological and grade or quality continuity between points of observation.
- A Measured Mineral Resource has a higher level of confidence than that applying to either an Indicated Mineral Resource or an Inferred Mineral Resource. It may be converted to a Proven Mineral Reserve or to a Probable Mineral Reserve.

14.14.2 Mineral Resource Classification for the Windfall Gold Deposit

Several criteria were considered for the gold resource classification into the Inferred, Indicated and Measured categories:

- The distance to the closest drill hole;
- The interpolation pass;
- The number of holes informing a grade block;
- The variogram ranges;
- The anisotropy ratio of search ellipsoids;
- The level of confidence in the continuity and the geological understanding of the mineralized lenses.

Table 14-20 presents the main criteria used to categorize the blocks in each class.

Table 14-20: Main criteria for resource classification

Resource category	Drill hole spacing (m)	Number of holes informing a block	Interpolation pass	Reliability of the geological and grade continuity
Measured	≤ 12.5	Mostly ≥ 4	First pass	Good and supported by underground workings
Indicated	≤ 25	Mostly ≥ 3	Mostly first pass	Good
Inferred	≤ 100	≥ 2	First to third pass	Moderate

A series of outline rings (or clipping boundaries) were created manually for each mineralized lens on longitudinal views using the classification criteria described above. The resource boundaries were drawn, keeping in mind that a significant cluster of blocks is necessary to delineate a resource category. In some cases, blocks that did not meet the criteria of a category were upgraded to that category to homogenize the class group (i.e., no “spotted dog” effect).



Blocks were assigned to the chosen resource category based on the classification clipping boundaries.

In some areas, interpolated blocks may not be classified due to the lack of confidence in grade and/or mineralization continuity, mainly where drill hole spacing is wide.

Figure 14-14 illustrates an example of the resource classification decision-making in lens 3311 in the Lynx Main zone.

The silver resource is reported based on the gold classification. Additionally, in Triple 8, the silver grade blocks were set to zero when: 1) blocks were poorly informed (less than two drill holes or wide spacing); or 2) the criteria of the interpolation passes were not met. These blocks were identified through queries or by using clipping boundaries.

Measured resources were defined in well-informed areas (drill spacing less than 12.5 m and blocks informed mostly by 4 holes) that have underground workings supporting the interpretation of the mineralization. Such criteria were met in the Zone 27 and Lynx Main zones.

Measured resources were divided in two codes:

- Blocks categorized as 3.0 are located within 10 m of the underground workings and mineralization is confirmed through underground observations;
- Blocks categorized as 3.1 are located further than 10 m from the underground workings.

The QP is comfortable with all blocks (3.0 and 3.1) being classified as Measured Resources. The distinction between 3.0 and 3.1 was made to provide additional information to Mining Engineers.

Some material included in the Measured Resources was mined as part of the Geological Characterization Works program, which is part of the Triple-Lynx Bulk sample permit. That material was hauled at surface in three stockpiles. The tonnage and gold grade of the stockpiles were estimated using the grade control model. The mined-out volumes were estimated from round-per-round survey points using a Leica TS16 total station for conventional development and from 3D modelling from GeoSLAM ZEB Horizon Lidar scanner survey for the stope volume. Densities by lithologies, ranging from 2.76 to 2.84, were used in the estimation of the tonnages. Gold grades were estimated based on muck samples with an average sample weight of 3.4 kg taken every 8-yard scoop bucket by a geology technician. This represents a rate of 1 muck sample per 9.3 tonnes of controlled material. The sampling capping varying between 60 g/t Au to 80 g/t Au were applied on the muck gold grade results. Gold grades were estimated with an average of muck samples results for every round tonnage. An Au tonne-weighted average per controlled volume is then reported for every stockpile. An average per silver grade estimate in the stockpiles were reported from the resource block model as silver was not analyzed in the muck samples.

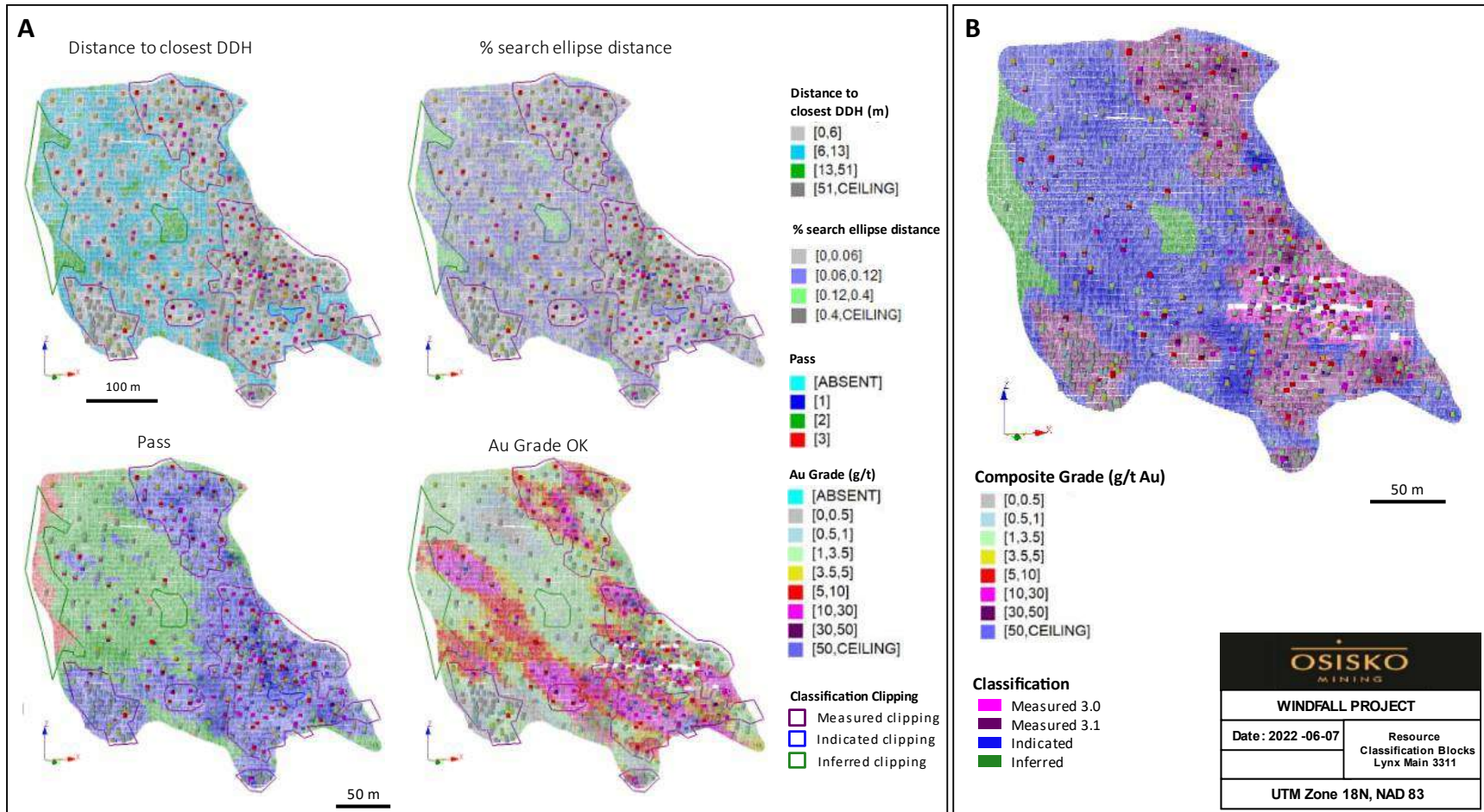

Figure 14-14: Example of resource classification for blocks in lens 3311 in Lynx Main zone
 A) Main criteria used for the decision-making in the drawing of the resource clipping boundaries; and B) Resource classification result



Constraining Volumes to Meet Reasonable Prospects for Eventual Economic Extraction

The mineral resource reported herein is not solely based on the application of a cut-off grade. To satisfy the reasonable prospects for eventual economic extraction for underground mining scenarios, as required by the CIM, blocks were included or excluded from the mineral resource based on the following mineable shape considerations:

1. Isolated and discontinuous blocks above the reported cut-off grade were excluded from the mineral resource.
2. Must-take material, i.e., isolated blocks below cut-off grade located within a potentially mineable volume, were included in the mineral resource.

The application of these conditions was performed in Studio RM on a per lens basis. The process involved grouping the Measured, Indicated, and Inferred blocks above the cut-off grade and grouping blocks below the cut-off grade, followed by filtering in or out of the resource the block clusters based on their volume and grade category. The clusters of blocks above cut-off grade for which the volume was less than 100 m³ (equivalent to the volume of two parent-size blocks) were excluded from the mineral resource. The clusters of blocks below cut-off grade (must-take material) for which the volume is less than 100 m³ were included in the mineral resource.

Figure 14-15 shows a comparison between the blocks selected above the cut-off grade and the reported blocks, including the blocks below the cut-off grade added in the mineral resource.

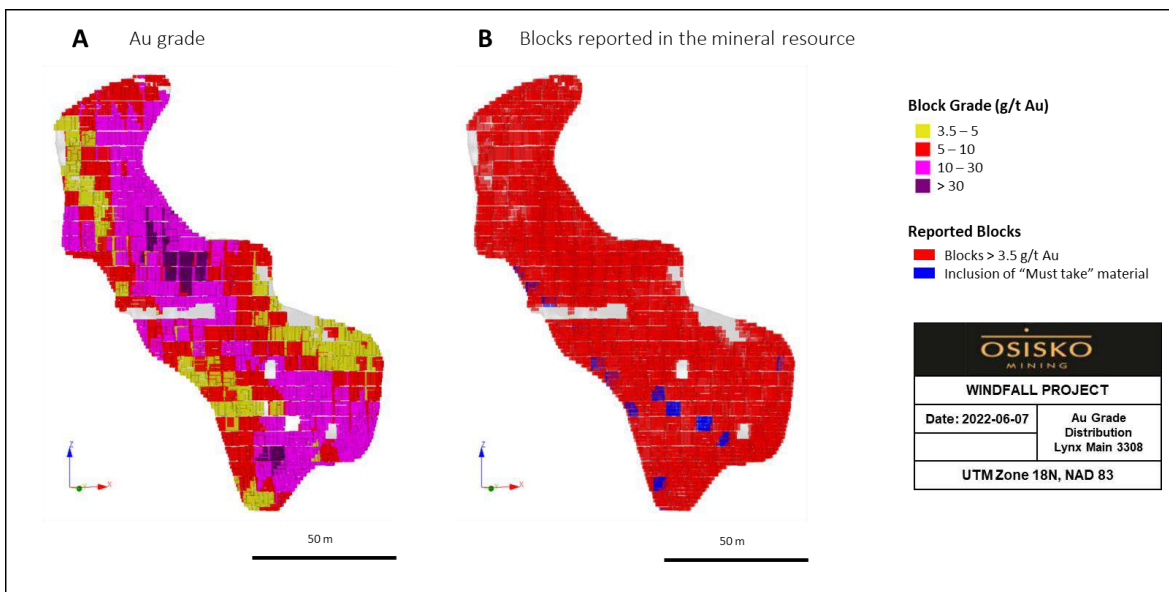

Figure 14-15: Example of blocks discarded or included in the mineral resource in lens 3308, Lynx Main zone
A) Selection of blocks above 3.5 g/t Au; B) Reported blocks based on the mineable shape criteria



14.15 Mineral Resource Estimate

Given the density of the processed data, the search ellipse criteria, the drilling density, and the specific interpolation parameters, the mineral resource estimate was classified as Measured, Indicated, and Inferred resources. The MRE was based on reliable quality data and reasonable hypotheses and parameters following the CIM Definition Standards.

Table 14-21 and Table 14-22 present the results of the MRE for the Windfall gold deposit at the 3.5 g/t Au cut-off grade. Table 14-23 presents the resource and sensitivity at other cut-off grade scenarios for all zones except for the stockpiles, which remained unchanged for all scenarios. The reader should be cautioned that the figures provided in Table 14-23 should not be interpreted as a mineral resource statement. The reported quantities and grade estimates at different cut-off grades are presented with the sole purpose of demonstrating the sensitivity of the resource model to the selection of varying reporting cut-off grades.



Table 14-21: Windfall gold deposit Mineral Resource inclusive of Mineral Reserves

Area	Measured					Indicated					Inferred				
	Tonnes ⁽¹⁾ (000 t)	Grade Au (g/t)	Grade Ag (g/t)	Ounces Au ⁽¹⁾ (000 oz)	Ounces Ag ⁽¹⁾ (000 oz)	Tonnes ⁽¹⁾ (000 t)	Grade Au (g/t)	Grade Ag (g/t)	Ounces Au ⁽¹⁾ (000 oz)	Ounces Ag ⁽¹⁾ (000 oz)	Tonnes ⁽¹⁾ (000 t)	Grade Au (g/t)	Grade Ag (g/t)	Ounces Au ⁽¹⁾ (000 oz)	Ounces Ag ⁽¹⁾ (000 oz)
Lynx ⁽²⁾	671	11.4	7.2	247	154	6,638	13.2	6.7	2,814	1,426	4,774	10.8	6.9	1,663	1,063
Underdog	–	–	–	–	–	928	9.5	3.4	284	101	4,072	7.7	3.0	1 011	397
Main ⁽³⁾	109	9.4	4.4	33	16	2,685	7.6	4.8	655	412	2,799	5.8	3.3	518	296
Triple 8	–	–	–	–	–	–	–	–	–	–	642	7.0	6.6	145	136
Total in situ	780	11.1	6.8	279	170	10,250	11.4	5.9	3,754	1,939	12,287	8.4	4.8	3,337	1,892
Stockpiles	32	16.9	4.3	17	4	–	–	–	–	–	–	–	–	–	–
Total	811	11.4	6.7	297	174	10,250	11.4	5.9	3,754	1,939	12,287	8.4	4.8	3,337	1,892

Notes:

(1) Values are rounded to nearest thousand which may result in apparent discrepancies.

(2) Lynx area includes: Lynx Main, Lynx HW, Lynx SW, Lynx 4, and Triple Lynx.

(3) Main area includes: Zone 27, Caribou 1, Caribou 2, Caribou Extension, Bobcat, Mallard, Windfall North, and F-Zones.

1. The independent qualified person for the 2022 MRE, as defined by NI 43-101 guidelines, is Pierre-Luc Richard, P. Geo. (OGQ#1119), of PLR Resources Inc. The effective date of the estimate is June 7, 2022.
2. The Windfall mineral resource estimate follows the November 29, 2019, CIM Estimation of Mineral Resources and Mineral Reserves Best Practice Guidelines.
3. These mineral resources are not mineral reserves as they have not demonstrated economic viability. The quantity and grade of reported Inferred mineral resources in this news release are uncertain in nature and there has been insufficient exploration to define these resources as Indicated or Measured; however, it is reasonably expected that the majority of Inferred mineral resources could be upgraded to Indicated mineral resources with continued exploration. Resources are presented undiluted and in situ and are considered to have reasonable prospects for economic extraction. Isolated and discontinuous blocks above the stated cut-off grade are excluded from the mineral resource estimate. Must-take material, i.e., isolated blocks below cut-off grade located within a potentially mineable volume, was included in the mineral resource estimate.
4. Mineral Resources are reported inclusive of those Mineral Resources converted to Mineral Reserves.
5. As of June 7, 2022, the database comprises a total of 4,834 drill holes for 1,852,861 m of drilling in the area extent of the mineral resource estimate, of which 4,152 drill holes (1,665,282 m) were completed and assayed by Osisko. The drill hole grid spacing is approximately 12.5 m x 12.5 m for definition drilling, 25 m x 25 m for infill drilling and larger for extension drilling.
6. All core assays reported by Osisko were obtained by analytical methods described below under "Quality Control and Reporting Protocols".
7. Geological interpretation of the deposit is based on lithologies, mineralization style, alteration, and structural features. Most mineralization envelopes are subvertical, striking NE-SW and plunging approximately 40 degrees towards the North-East. The 3D wireframing was generated in Leapfrog Geo, a modelling software, from hand selections of mineralization intervals. The mineral resource estimate includes a total of 579 tabular, mostly sub-vertical domains defined by individual wireframes with a minimum true thickness of 2.0 m.



8. Assays were composited within the mineralization domains into 2.0 m length composites. A value of 0.00125 g/t Au and 0.0025 g/t Ag ($\frac{1}{4}$ of the detection limit) was applied to unassayed core intervals.
9. High-grade composites were capped. Capping was determined in each zone from statistical studies on groups of lenses sharing similar mineralization characteristics. Capping varies from 6 g/t Au to 200 g/t Au and from 5 g/t Ag to 150 g/t Ag. A three-pass capping strategy defined by capping values decreasing as interpolation search distances increase was used in the grade estimations.
10. Block models were produced using Datamine™ Studio RM Software. The models are defined by parent cell sizes of 5 m EW, 2 m NS and 5 m height, and sub-blocked to minimum sub-cell sizes of 1.25 m EW, 0.5 m NS and 1.25 m height.
11. Ordinary Kriging (OK) based interpolations were produced for gold estimations in each zone of the Windfall deposit, while silver grade estimations were produced using Inverse Distance Squared (ID2) interpolations. Gold estimation parameters are based on composite variography analyses. The gold estimation parameters were used for the silver estimation.
12. Density values between 2.74 and 2.93 were applied to the mineralized lenses.
13. The Windfall mineral resource estimate is categorized as Measured, Indicated, and Inferred mineral resource as follows:
 - The Measured mineral resource category is manually defined and encloses areas where:
 - I. drill spacing is less than 12.5 m;
 - II. blocks are informed by mostly four drill holes;
 - III. geological evidence is sufficient to confirm geological and grade continuity;
 - IV. lenses have generally been accessed by underground workings.
 - The Indicated mineral resource category is manually defined and encloses areas where:
 - I. drill spacing is generally less than 25 m;
 - II. blocks are informed by mostly three drill holes;
 - III. geological evidence is sufficient to assume geological and grade continuity.
 - The Inferred mineral resource category is manually defined and encloses areas where:
 - I. drill spacing is less than 100 m;
 - II. blocks are informed by a minimum of two drill holes;
 - III. geological evidence is sufficient to imply, but not verify geological and grade continuity.
14. Tonnage and gold grade of the stockpiles were estimated using the grade control model. Densities by lithologies, ranging from 2.76 to 2.84, were used in the estimation of the tonnages. Gold grades were estimated with an average of muck samples results for every round tonnage, based on muck samples with an average sample weight of 3.4 kg taken every 8-yard scoop bucket. The sampling capping varying between 60 g/t Au to 80 g/t Au was applied on the muck gold grade results. An average per silver grade estimates in the stockpiles was reported from the resource block model as silver was not analyzed in the muck samples.
15. The mineral resource is reported at 3.5 g/t Au cut-off. The cut-off grade is based on the following economic parameters: gold price at 1,600 USD/oz, exchange rate at 1.28 USD/CAD, 93% mill recovery; payability of 99.95%; selling cost at 5 USD/oz, 2% NSR royalties, mining cost at 125 CAD/t milled, G&A cost at 39 CAD/t milled, processing cost at 42 CAD/t, and environment cost at 4 CAD/t.
16. Estimates use metric units (metres (m), tonnes (t), and g/t). Metal contents are presented in troy ounces (metric tonne x grade / 31.103475).
17. The independent qualified person is not aware of any known environmental, permitting, legal, title-related, taxation, socio-political or marketing issues, or any other relevant issue that could materially affect the mineral resource estimate.



Table 14-22: Windfall gold deposit Measured, Indicated, and Inferred mineral resources detailed by zone

Zone	Measured + Indicated					Inferred				
	Tonnes (000 t)	Grade Au (g/t)	Grade Ag (g/t)	Ounces Au (000 oz)	Ounces Ag (000 oz)	Tonnes (000 t)	Grade Au (g/t)	Grade Ag (g/t)	Ounces Au (000 oz)	Ounces Ag (000 oz)
Lynx Main	1,750	10.3	6.5	579	366	151	7.7	4.6	37	22
Triple Lynx	3,229	12.9	4.0	1,337	415	2,057	9.4	3.1	625	203
Lynx SW	383	7.6	4.3	93	53	330	7.4	3.2	78	34
Lynx 4	1,628	18.1	13.0	947	680	2,100	13.2	11.6	889	782
Lynx HW	319	10.1	6.7	104	68	136	7.7	5.1	34	22
Underdog	928	9.5	3.4	284	101	4,072	7.7	3.0	1,011	397
Zone 27	1,110	7.9	5.7	282	204	201	6.5	4.1	42	27
Caribou 1	272	5.7	6.0	50	53	129	5.1	4.0	21	17
Caribou 2	838	8.0	4.4	214	119	719	6.9	3.7	159	85
Caribou Extension	3	4.7	3.7	0	0	617	4.6	4.3	90	85
Bobcat	189	6.9	5.1	42	31	392	6.0	4.2	75	53
Mallard	124	8.1	2.5	32	10	335	5.5	1.6	60	18
Windfall North	32	7.4	2.9	8	3	60	5.6	1.4	11	3
F-Zones	226	8.0	1.1	58	8	347	5.4	0.8	60	9
Triple 8	-	-	-	-	-	642	7.0	6.6	145	136
Stockpiles	32	16.9	4.3	17	4					
Total	11,061	11.4	5.9	4,050	2,110	12,287	8.4	4.8	3,337	1,892

Note: The notes listed in Table 14-21 apply to this table.



Table 14-23: Windfall Project Measured, Indicated, and Inferred mineral resource sensitivity table

Cut-off Grade (g/t Au)	Measured + Indicated					Inferred				
	Tonnes (000 t)	Grade Au (g/t)	Grade Ag (g/t)	Ounces Au (000 oz)	Ounces Ag (000 oz)	Tonnes (000 t)	Grade Au (g/t)	Grade Ag (g/t)	Ounces Au (000 oz)	Ounces Ag (000 oz)
5.0	8,213	13.9	7.0	3,667	1,854	7,986	10.7	6.0	2,760	1,545
4.5	9,029	13.1	6.7	3,791	1,935	9,078	10.0	5.6	2,927	1,638
4.0	9,950	12.2	6.3	3,917	2,020	10,561	9.2	5.2	3,129	1,754
3.5	11,061	11.4	5.9	4,050	2,114	12,287	8.4	4.8	3,337	1,892
3.0	12,388	10.5	5.6	4,188	2,217	14,299	7.7	4.4	3,547	2,033
2.5	13,951	9.6	5.2	4,326	2,330	17,178	6.9	4.0	3,801	2,219

Notes:

1. Values are rounded to nearest thousand, which may result in apparent discrepancies.
2. MRE cut-off: 3.5 g/t Au.
3. The cut-off grade variation is not applicable to the material in the Stockpiles.

Most reported Measured and Indicated ounces are located within 1 km below surface. Figure 14-16 and Figure 14-17 show the distribution of Measured, Indicated and Inferred blocks reported in the mineral resource in the Windfall deposit. Table 14-24 to Table 14- report the mineral resource by vertical slices of 100 m throughout the Windfall deposit. The distribution of ounces by elevation presents an overview of the gold ounces per metres by resource categories and area.

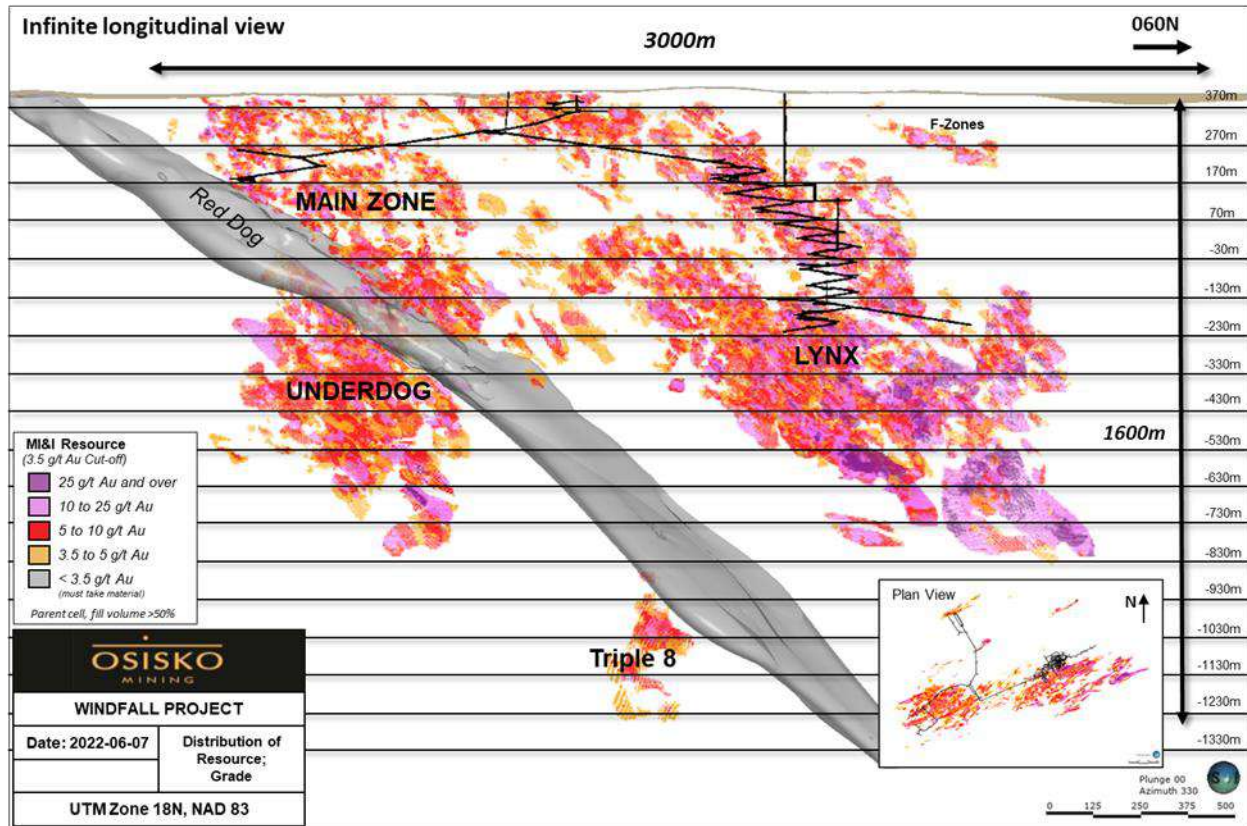

Figure 14-16: Long section view (looking northwest) showing the distribution of the block grades of the Windfall Mineral Resource

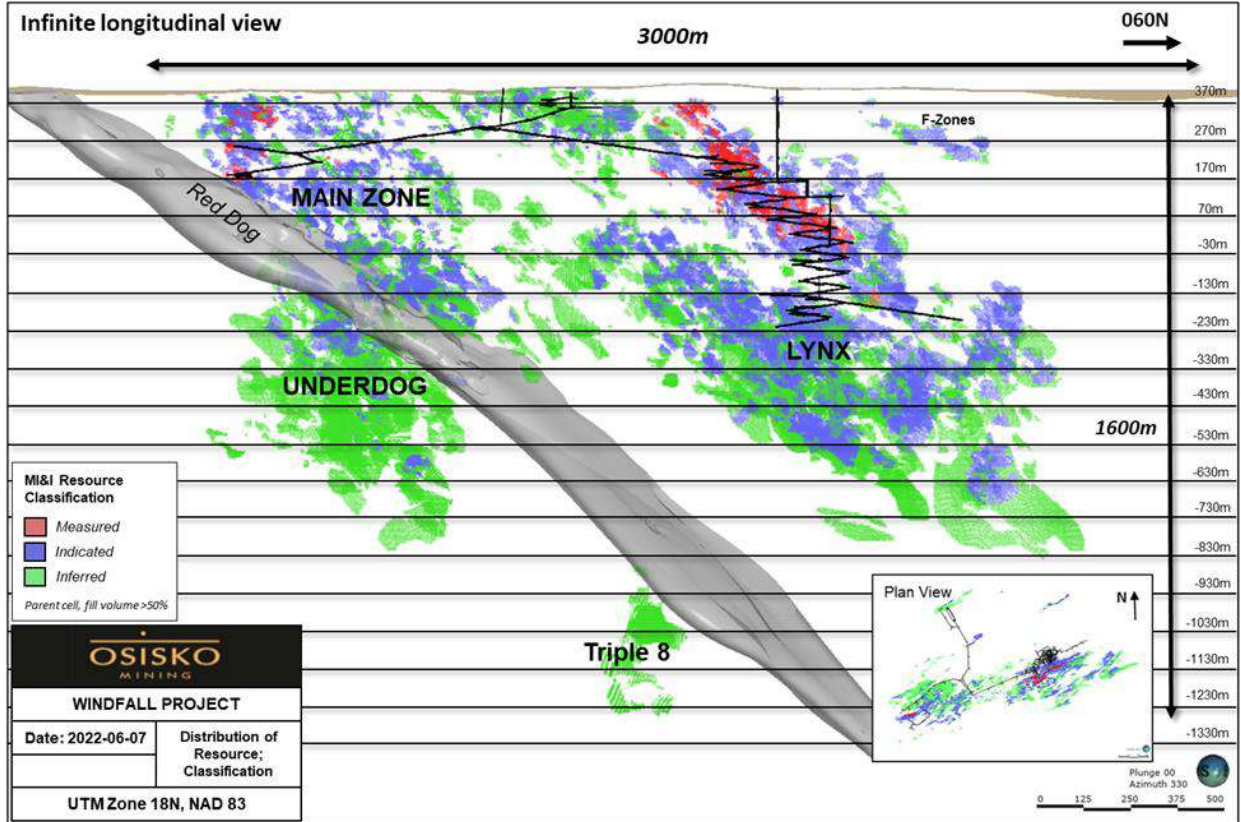

Figure 14-17: Long section view (looking northwest) showing the distribution of the blocks by resource category for the Windfall Mineral Resource

Table 14-24: Windfall Project, Measured, Indicated, and Inferred mineral resource by depth for the Main Underdog, and Triple 8 Areas

	Elevation (slice 100 m)	Main, Underdog & Triple 8 Areas							
		Measured & Indicated				Inferred			
		Tonnes (000 t)	Grade Au (g/t)	Ounces Au (000 oz)	oz/m	Tonnes (000 t)	Grade Au (g/t)	Ounces Au (000 oz)	oz/m
In situ	370	96	7.5	23	582	166	6.3	33	836
	270	747	7.7	186	1,857	648	5.7	120	1,199
	170	449	7.2	105	1,047	271	5.2	45	451
	70	447	8.1	116	1,160	280	5.4	48	482
	-30	239	6.6	51	509	293	5.5	52	520
	-130	557	8.3	148	1,480	591	6.1	116	1,157
	-230	639	9.2	190	1,898	808	7.1	184	1,837
	-330	263	8.5	72	718	724	8.0	186	1,864
-430	180	8.8	51	510	1,045	7.3	246	2,459	



	Elevation (slice 100 m)	Main, Underdog & Triple 8 Areas							
		Measured & Indicated				Inferred			
		Tonnes (000 t)	Grade Au (g/t)	Ounces Au (000 oz)	oz/m	Tonnes (000 t)	Grade Au (g/t)	Ounces Au (000 oz)	oz/m
	-530	35	6.1	7	73	979	6.8	215	2,149
	-630	68	11.0	24	241	696	7.4	166	1,659
	-730	-	-	-	-	247	11.5	92	916
	-830	-	-	-	-	123	6.7	27	265
	-930	-	-	-	-	10	6.9	2	31
	-1,030	-	-	-	-	244	8.8	69	691
	-1,130	-	-	-	-	274	6.3	55	554
	-1,230	-	-	-	-	74	5.3	13	125
	-1,370	-	-	-	-	40	4.3	5	156
Total		3,721	8.1	972	-	7,513	6.9	1,674	-

Table 14-25: Windfall Project, Measured, Indicated, and Inferred mineral resource by depth for the Lynx area

	Elevation (slice 100 m)	Lynx Area							
		Measured & Indicated				Inferred			
		Tonnes (000 t)	Grade Au (g/t)	Ounces Au (000 oz)	oz/m	Tonnes (000 t)	Grade Au (g/t)	Ounces Au (000 oz)	oz/m
In situ	370	3	6.2	1	45	-	-	-	-
	270	130	8.6	36	359	5	7.2	1	30
	170	462	9.3	139	1,387	44	6.1	9	86
	70	599	9.6	185	1,847	52	6.3	11	105
	-30	653	9.6	202	2,016	154	6.5	32	323
	-130	536	8.9	154	1,537	272	7.6	66	663
	-230	1,163	13.5	506	5,056	402	8.5	110	1,102
	-330	1,516	13.8	671	6,709	700	8.6	193	1,929
	-430	942	14.6	441	4,414	982	11.0	348	3,476
	-530	871	13.2	369	3,694	776	8.7	217	2,173
	-630	344	26.4	292	2,921	624	13.9	279	2,794
	-730	89	23.1	66	883	422	15.6	211	2,110
-830	-	-	-	-	338	17.1	186	1,856	
-930	-	-	-	-	3	4.2	0	20	
Total in situ	-	7,309	13.0	3,061	-	4,774	10.8	1,663	-
Stockpiles	-	32	16.9	17	-	-	-	-	-
Total	-	7,340	13.0	3,078	-	4,774	10.8	1,663	-



Table 14-26: Windfall Project, Measured, Indicated, and Inferred mineral resource by depth

	Elevation (slice 100 m)	Windfall Project							
		Measured & Indicated				Inferred			
		Tonnes (000 t)	Grade Au (g/t)	Ounces Au (000 oz)	oz/m	Tonnes (000 t)	Grade Au (g/t)	Ounces Au (000 oz)	oz/m
In situ	370	99	7.5	24	599	166	6.3	33	836
	270	878	7.9	222	2,216	654	5.8	121	1,211
	170	911	8.3	243	2,434	315	5.3	54	538
	70	1,046	8.9	301	3,008	332	5.5	59	588
	-30	893	8.8	252	2,524	447	5.9	84	843
	-130	1,094	8.6	302	3,017	863	6.6	182	1,820
	-230	1,802	12.0	695	6,954	1,210	7.6	294	2,939
	-330	1,780	13.0	743	7,427	1,424	8.3	379	3,794
	-430	1,122	13.7	492	4,924	2,027	9.1	593	5,934
	-530	906	12.9	376	3,763	1,755	7.7	432	4,322
	-630	412	23.9	316	3,161	1,320	10.5	445	4,452
	-730	89	23.1	66	883	668	14.1	303	3,025
	-830	–	–	–	–	461	14.3	212	2,122
	-930	–	–	–	–	13	6.2	3	26
	-1,030	–	–	–	–	244	8.8	69	691
	-1,130	–	–	–	–	274	6.3	55	554
-1,230	–	–	–	–	74	5.3	13	125	
-1,370	–	–	–	–	40	4.3	5	156	
Total in situ	–	11,030	11.4	4,033	–	12,287	8.4	3,337	–
Stockpiles	–	32	16.9	17	–	–	–	–	–
Total	–	11,061	11.4	4,050	–	12,287	8.4	3,337	–



14.16 Comparison to Previous Mineral Resource Estimates

The previous MRE published on the Windfall Project was filed on February 10, 2022 (see Technical Report entitled “Mineral Resource Estimate Update for the Windfall Project, Eeyou Istchee James Bay, Québec, Canada”, effective date October 20, 2021) (Richard et al., 2022) and is available on SEDAR (www.sedar.com) under Osisko Mining Inc.

Compared to the previous MRE, the Measured and Indicated resource has increased by 8% in average grade, and by 26% in ounces, adding 846,000 ounces in the M&I resource categories. The 2022 drilling campaign largely focused on the transfer of Inferred resources into Indicated resources – mainly in the Lynx area that has increased by 9% in grade, and 33% in ounces (754,000 ounces added) in the M&I categories. Following the resource category transfer, the Inferred resources have decreased by 7%, a loss of 248,000 ounces (-6%, -114,000 ounces in Lynx area). The increase in Measured and Indicated resources shows that the infill drilling targeting Inferred resources efficiently upgraded these resources to resource categories of higher confidence.

The resource comparison is presented in Table 14-27.

The 2022 infill drilling program provided additional geological and assay information to support the mineralization model. More specifically, the additional drill hole data has 1) increased the confidence in the mineralization continuity at a tighter drill spacing (25 m) in the Lynx Main, Triple Lynx, Lynx 4, Caribou 2, and Underdog zones; 2) allowed to refine the mineralization model including the addition of some new lenses, the extension of some lens wireframes, as well as adjustments of lenses along geological structures; and 3) supported the use of a higher capping threshold (120 g/t Au) in the Triple Lynx high-grade lenses.

Although Caribou 1, Caribou Extension, Bobcat, Mallard, and Triple 8 areas generally did not receive new drilling information since the previous MRE, minor changes are seen in their results. This is mainly due to the reprocessing of the block models using an unrotated prototype (previously rotated 25° counterclockwise). This change was made to facilitate the various usages of the block model.



Table 14-27: Comparison of the 2022 MRE to the previous October 2021 MRE

Area	MRE 2022						MRE October 2021					
	Measured and Indicated			Inferred			Measured and Indicated			Inferred		
	Tonnes	Grade	Ounces	Tonnes	Grade	Ounces	Tonnes	Grade	Ounces	Tonnes	Grade	Ounces
	000 t	g/t Au	000 oz Au	000 t	g/t Au	000 oz Au	000 t	g/t Au	000 oz Au	000 t	g/t Au	000 oz Au
Lynx	7,309	13.0	3,061	4,774	10.8	1,777	5,996	12.0	2,307	5,052	10.9	1,777
Underdog	928	9.5	284	4,072	7.7	1,119	800	9.5	244	4,419	7.9	1,119
Main	2,793	7.7	688	2,799	5.8	540	2,676	7.6	654	2,909	5.8	540
Triple 8	-	-	-	642	7.0	145	-	-	-	655	7.1	149
Stockpiles	32	16.9	17	-	-	-	-	-	-	-	-	-
Total	11,061	11.4	4,050	12,287	8.4	3,337	9,472	10.5	3,204	13,035	8.6	3,585

14.17 Mineralization Potential Upside

The potential for adding new resources with additional drilling on the Project is good at depth, mainly in the Lynx and Underdog areas. The mineralization is open down plunge and towards the northeast as supported by deeper drill holes.

The hole OSK-W-19-1970(-W1) also known as Discovery 1, was drilled in 2019-2020 to target the down plunge extension of Underdog and Triple 8 mineralized corridors and to test the potential for deep felsic intrusive centres driving the Windfall mineralized system. Several anomalous gold intervals were intersected at depth, notably 1.04 g/t Au over 191 m from 3,139 m to 3,330 m, providing valuable insights on the deeper potential of the Windfall deposit (refer to Figure 14-18).

Between 2015 and 2022, many drill holes completed on the Windfall Project confirmed mineralization and gold grade in the down plunge extension of several mineralized corridors and lenses. The long-term potential seen in Figure 14-19 is interpreted and supported by the well documented main plunge of the Windfall deposit and the many drill hole intercepts outside of the mineral resource estimate.

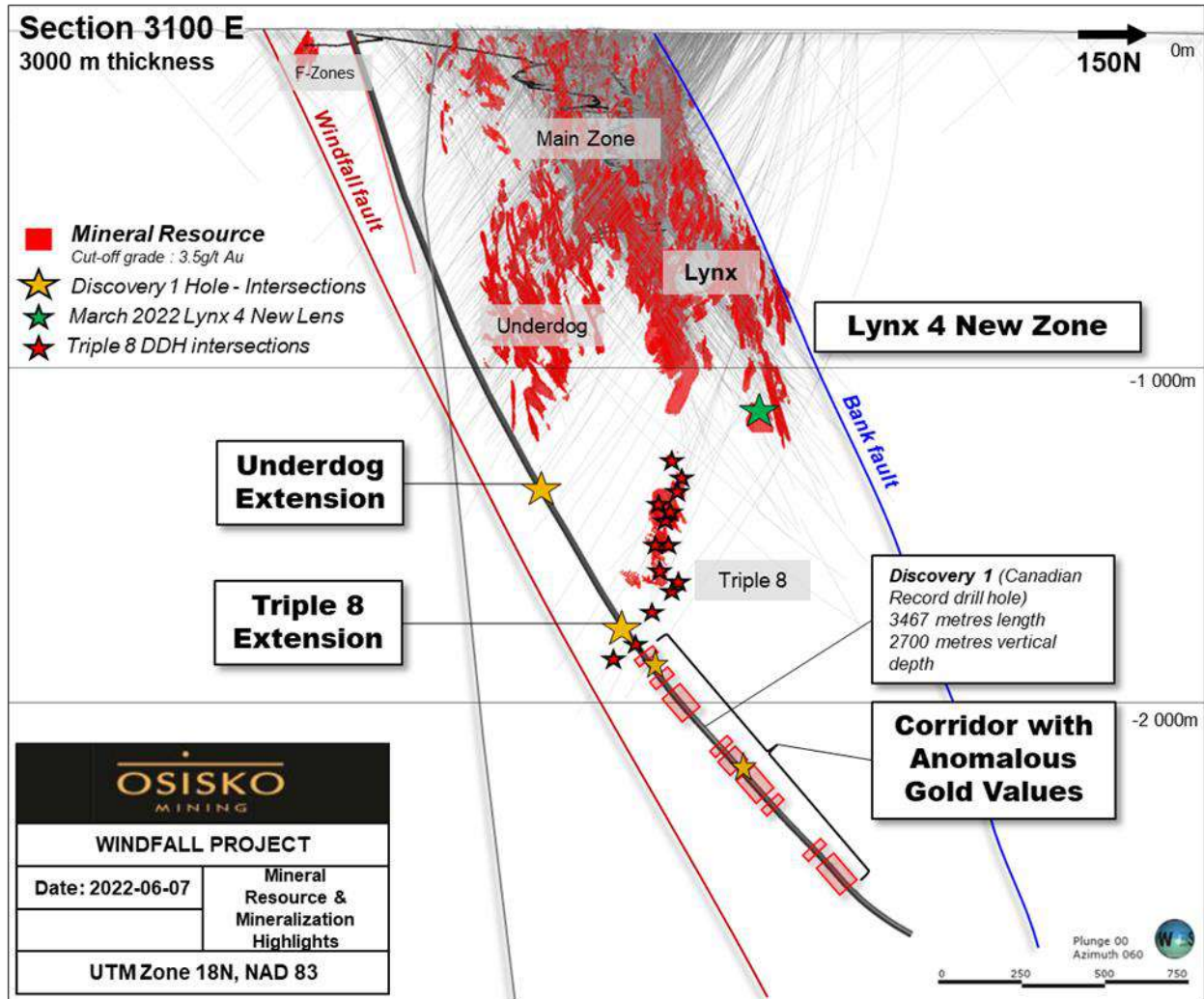

Figure 14-18: Several gold anomalous intervals intercepted at depth

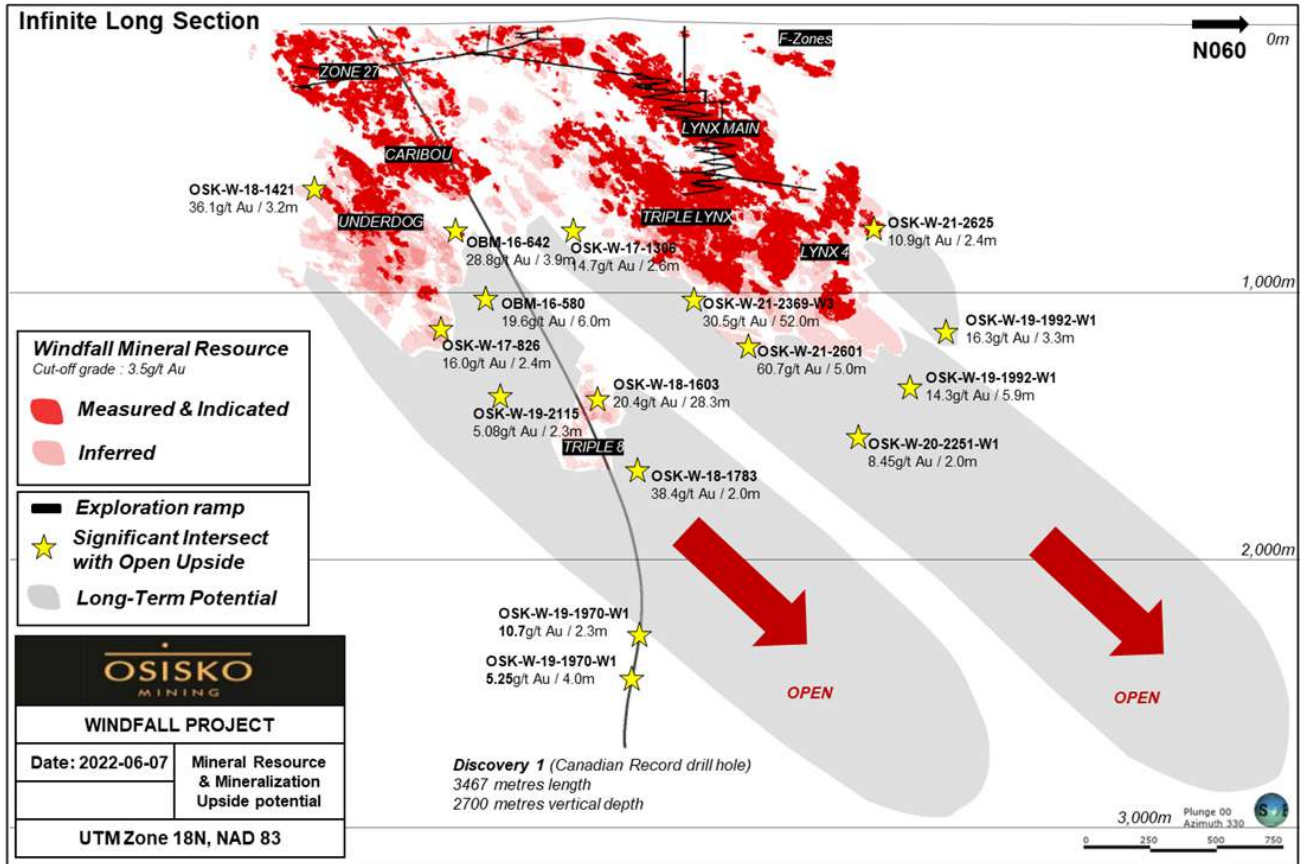

Figure 14-19: Long-term potential along the main plunge of the Windfall deposit



15. Mineral Reserve Estimates

15.1. Mineral Reserve Estimation Process

A process was followed to convert the Mineral Resources to Mineral Reserves, which is supported by the design, schedule, and economic evaluation completed by Entech. Entech's general conversion process is described in the following points, with further detail provided in subsequent sections.

- A set of 14 Mineral Resource models, dated June 7, 2022, were provided by Osisko to Entech;
- The mineral resource model was imported into Datamine and modelled grades within the inferred material were set to zero. Stope optimizations were completed using Datamine Mineable Shape Optimiser® considering an economic cut-off grade of 3.5 g/t Au. Unplanned dilution was added during the MSO stage, with shapes optimized for grade before applying the minimum 0.5 m hanging wall and 0.5 m footwall dilution. The resulting stope shapes were reviewed for practicality of mining, with unpractical mining shapes removed;
- Modifying factors were applied to these stope shapes, including backfill dilution and recovery factors, based on Windfall's predicted dilution factors and industry average recovery performance;
- A development design was produced to align with the resulting stope shapes that tied into the existing underground as-builts. The development design follows current site design criteria and A2GC geotechnical recommendations. A development ore dilution factor of 12% and recovery factor of 98% was applied;
- Stope shapes were depleted with development drives. Estimated mining recoveries for stoping were 92% for stopes with an overcut and undercut, and 85% for stopes with an undercut only;
- The mine design was then depleted with current site as-builts provided by Osisko up to November 3, 2022;
- All stope and development designs (the mine design) were then evaluated;
- Levels were then evaluated using the cost and revenue assumptions applied in the cut-off grade estimation and sub-economic levels and stopes were removed from the Mineral Reserve;
- The mine design was sequenced and scheduled in Deswik® to produce a mine plan;
- The resulting plan was evaluated in a financial model based on estimated mining costs to confirm economic potential.



The resulting Mineral Reserve estimate is shown in Table 15-1.

Table 15-1: Windfall gold deposit Mineral Reserves

Area	Probable				
	Tonnes	Grade Au	Grade Ag	Ounces Au	Ounces Ag
	(000 t)	(g/t)	(g/t)	(000 oz)	(000 oz)
Lynx ⁽¹⁾	8,882	8.83	4.58	2,523	1,307
Underdog	906	6.80	2.31	198	67
Main ⁽²⁾	2,363	5.55	3.44	422	261
Total in-situ	12,151	8.04	4.19	3,143	1,635
Stockpiles	33	15.24	3.74	16	4
Total	12,183	8.06	4.18	3,159	1,639

Notes:

⁽¹⁾ Lynx area includes: Lynx Main, Lynx HW, Lynx SW, Lynx 4, and Triple Lynx.

⁽²⁾ Main area includes: Zone 27, Caribou 1, Caribou 2, Caribou Extension, Bobcat, Mallard, Windfall North, and F-Zones.

1. The independent qualified person for the 2022 MRE, as defined by NI 43-101 guidelines, is Patrick Langlais, P. Eng. (OIQ#6021556), of Entech Mining Ltd. The effective date of the estimate is November 25, 2022.
2. The Windfall Mineral Reserve Estimate follows the May 19, 2014 "CIM Definition Standards - For Mineral Resources and Mineral Reserves" and the November 29, 2019 "CIM Estimation of Mineral Resources and Mineral Reserves Best Practice Guidelines".
3. These Mineral Reserves have been diluted based on geotechnical recommendations and have had a mining recovery applied.
4. Values are rounded to nearest thousand, which may result in apparent discrepancies.
5. The Mineral Reserve is depleted for all mining to November 3, 2022.
6. The Mineral Reserve is reported using a 3.5-g/t break-even, a 2.5-g/t stope incremental, and a 1.7-g/t marginal cut-off grade.
7. All Measured Mineral Resources have been classified as Probable Mineral Reserve.
8. Stockpile values were provided by Osisko and account for less than 0.1% of Mineral Reserve ounces.
9. Estimates use metric units (metres (m), tonnes (t), and g/t). Metal contents are presented in troy ounces (metric tonne x grade / 31.103475).
10. The independent qualified person is not aware of any known environmental, permitting, legal, title-related, taxation, socio-political or marketing issues, or any other relevant issue that could materially affect the Mineral Reserve Estimate.



15.2. Stope Design Parameters

The following stope design parameters were applied within the mine design:

- Minimum footwall dip angles were set at 45°;
- Minimum mining widths (excluding unplanned dilution) of 2.0 m;
- Minimum unplanned dilution of 0.5 m on the footwall and hanging wall of each stope shape (total of 1.0 m of dilution) applied as part of the stope optimization process. The predicted dilution is evaluated with the Mineral Resource model and therefore, dilution may carry grade based on the resource model. Fill dilution was additional and added dependent on wall exposure;
- Geotechnical stress modelling completed with a preliminary schedule, dated August 2, 2022, identified further increases in dilution on the footwall and hanging wall in specific regions. Further details can be found in Table 16-12;
- Geotechnical stress modelling identified 48 sill pillar stopes that are anticipated to experience moderate to high stress conditions. A revised mining recovery factor of 60% for moderate stress and 50% for high stress has been applied to these stopes to account for difficult mining conditions and mucking recovery losses.

15.3. Preliminary Cut-off Grade Derivation

Cut-off grades used in the design and scheduling process are based on preliminary revenue inputs and calculated study costs as stated in Table 15-2.

Table 15-2: Cut-off grade inputs

Factor	Unit	Assumption
Gold Price	USD/oz	1,600
Exchange Rate	USD/CAD	1.3
NSR	%	2.0
Mill Recovery	%	93
Total Revenue per Ounce of Gold	\$/oz	1,900
Processing, Tailings, Waste and Water Management Costs	\$/t ore	52
Mining Direct Operating Costs (Incl. Operating Development)	\$/t ore	86
Site G&A	\$/t ore	40
Sustaining Capital	\$/t ore	21
Preliminary Mining Cost	\$/t ore	199



When completing the initial stope optimization process, a 3.5 g/t Au break-even cut-off grade was applied. For incremental stopes on levels that had already covered capital costs, a 2.5 g/t Au incremental cut-off grade was applied. For development required to access stopes, a 1.7 g/t Au marginal cut-off grade of was applied, which covers the processing, general and administration cost, as mining and haulage of this material is a cost already incurred to access stope material. The preliminary cut-off grades are summarized in Table 15-3.

Table 15-3: Preliminary Cut-off grades

Break-Even Cut-off Grade (g/t)	Incremental Cut-off Grade (g/t)	Marginal Cut-off Grade (g/t)
3.5	2.5	1.7

15.4. Preliminary Economic Potential

After depletion of stope shapes with the development, the economic potential of individual stopes for inclusion in the Mineral Reserve were evaluated using the cost and revenue assumptions summarized in Table 15-4. For contiguous zones, all operating costs were included in the analysis. For isolated mineralized zones (pods / orphans), site general and administration costs (surface only) were excluded to allow for maximum recovery, as costs were preliminary at this stage.

Table 15-4: Stope economics parameters

Stope Economic Inputs	Unit	Unit Rate
Mining Cost (Excl. Operating Development)	\$/t	60
Processing, Tailings, Waste and Water Management	\$/t	52
Development Cost - Lateral CAPEX	\$/m	5,000
Development Cost - Lateral OPEX	\$/m	4,000
Development Cost - Vertical	\$/m	13,000
Revenue per Ounce of Gold	\$/oz CAD	1,900

15.5. Final Economic Analysis

Once the mining design and schedule were complete, a final economic analysis was completed on a level per level basis, and then each individual stope was checked that all material defined as "ore" continued to return positive cashflow.



The cut-off grades based on application to the reserve are summarized in Table 15-5. These values were derived from the feasibility financial model completed on November 25, 2022. Variance between these final values and the preliminary values used in the mine design are within the accuracy level required of this study.

Table 15-5: Feasibility Study operating costs and cut-off grade calculation for the Windfall Project

Operating Costs	Unit	Full Economic Cut-off Grade	Incremental Cut-off Grade	Marginal Cut-off Grade
Mining costs				
Stope operating costs	\$/t ore	62	62	
Operating development costs	\$/t ore	21		
Sustaining capital (excl. development)	\$/t ore	26		
Processing including filtration costs	\$/t ore	41	41	41
Waste and water management costs	\$/t ore	6	6	6
G&A costs	\$/t ore	33	33	33
Electrical transmission line lease cost	\$/t ore	15	15	15
Total Operating Cost	\$/t ore	203	156	94
Break-Even Stope cut-off grade	g/t Au	3.4		
Incremental Stope cut-off grade	g/t Au		2.6	
Marginal cut-off grade	g/t Au			1.6



16. Mining Methods

16.1 Introduction

The Mineral Resources used in the mine plan are contained in three different zones (Lynx, Main and Underdog) over a strike length of 2,300 m, and extends from surface to a depth of approximately 1,100 m. Each zone is characterized by multiple veins, which mainly trend ENE and have a vertical-to-subvertical plunge. The underground mining selected for this Study is longitudinal longhole stoping with backfill. The stope dimensions are 20 m in height, vary from 10 m to 30 m in strike, and have a minimum thickness of 3.0 m. All material will be extracted using a fleet of 14 t and 18 t load-haul-dumps (“LHDs”) and 54 t haul trucks, at an average rate of 5,000 tpd (inclusive of waste).

16.2 Rock Engineering

This section is summarized from the rock engineering study completed in support of the mine design (A2GC, 2022). The rock engineering study was completed based on a preliminary life of mine (“LOM”) stope layout and mining sequence (dated August 2, 2022) to allow for sufficient time to include the geomechanical guidelines in the final mine design.

16.2.1 Geomechanical Rock Mass Conditions

16.2.1.1 In-situ Stress Conditions

Stress measurements were conducted by Sigra Pty Ltd. (“Sigra”) at Windfall in Fall 2021. Measurements were taken using the Sigra over-coring stress test tool, testing two horizons at 300 m and 600 m below surface.

Table 16-1 summarizes the in-situ stress tensor considered for the Project, based on the stress testing results. A bilinear gradient was retained with a first segment for shallower depths (0 m to 300 m) and a second segment for depths between 300 m and 1,500 m.



Table 16-1: In situ stress tensors considered for the Windfall Project

Principal stress component	Orientation (dip/azimuth)	Magnitude (MPa)	
		0 – 300 m	300 – 1,500 m
Major principal stress σ_1	00° / 035°	3.55 σ_3 + 8.38	2.33 σ_3 + 6.75
Intermediate principal stress σ_2	00° / 125°	0.84 σ_3 + 29.50	0.63 σ_3 + 20.00
Minor principal stress σ_3	90° / 000°	0.026 z Where z is the depth in metres	

16.2.1.2 Rock Mass Geomechanical Domains

The geological settings of the Windfall deposit are complex. The lithology units across the different mining zones are generally strong, hard and brittle rock masses, sparsely jointed-to-blocky. The volcanic rocks exhibit various intensities of foliation, but the foliation is generally strong. The rock mass quality becomes significantly lower inside the boundaries of, and in proximity to, the interpreted faults.

Geomechanical domains were grouped by lithology, based on geological origin, composition (felsic or mafic) and strength testing data. Table 16-2 summarizes the geomechanical domains for the Project.

Table 16-2: Geomechanical domains considered for the Windfall Project

Geomechanical Domain	Lithology	
1- Mafic rocks	V2 I3A I4	
2- Felsic intrusives	I1 Frg I1P TrY I1P YB I1P YL	I2F I2J I2P I13
3- Felsic volcanics	V1	



16.2.1.3 Available Geotechnical Data

The available geomechanical data from drill holes are summarized in Table 16-3. The drill hole data have been collected along specified intervals in selected exploration drill holes, principally around the mineralization lenses. The Osisko engineering team on-site is also performing geotechnical scanline mapping on a regular basis in the exploration development.

Rock quality data (“RQD”) is regularly measured as part of the exploration logging. An RQD block model provided by Osisko (dated May 2022) was used as input for the numerical modelling analyses.

A supplemental strength testing program was conducted in 2022 to add to the geomechanical domains grouping.

The amount and quality of data is sufficient for this level of study. Data gaps are discussed in A2GC (2022).

Table 16-3: Summary of available geotechnical data from drill holes for the Windfall Project

Type of data	Golder, 2018	Golder, 2020	A2GC 2020	A2GC 2022
Detailed geomechanical core logging	1,118 m (3 holes)	3,580 m (11 holes)	1,118 m (3 holes)	–
Summary geomechanical core logging	359 m (3 holes)	359 m (8 holes)	–	–
Televiewer surveys	2,371 m (6 holes)	–	–	–
Laboratory testing	16 UCS ⁽¹⁾ tests 9 UCSE ⁽²⁾ tests 18 TCS ⁽³⁾ tests 12 BTS ⁽⁴⁾ tests	20 UCS tests 6 UCSE tests 12 TCS tests 12 BTS tests	11 UCS tests 5 UCSE tests 15 TCS tests 11 BTS tests	3 UCS tests 6 UCSE tests 28 TCS tests 5 BTS tests
Point load tests	374 tests	1,592 tests	330 tests	No further testing

Notes:

- (1) UCS = Unconfined compressive strength.
- (2) UCSE = Unconfined compressive strength with measurements of elastic properties.
- (3) TCS = Confined triaxial compressive strength.
- (4) BTS = Indirect splitting tensile strength (Brazilian test).



16.2.1.4 Intact Rock Properties

The normalized peak unconfined compressive strength (UCS_{50}), indirect splitting tensile strength ("BTS") and elastic properties (Young's modulus and Poisson's ratio) of the intact rock units were determined from the laboratory tests performed on rock core samples. The values per geomechanical domain are shown in Table 16-4. Tests that have failed along a pre-existing discontinuity were excluded from the analysis.

It should be noted that the Red Dog dike, classified as the I2F lithology, is part of the geomechanical domain that regroups all felsic dikes. Based on the intact strength test results, this grouping was believed to be reasonable at this stage. However, it is possible that some intrusive units were not well represented in the dataset and that their effect will be underestimated. Data gaps are discussed in A2GC (2022).

Table 16-4: Summary of laboratory test results per geomechanical domain

Domain	UCS_{50}		BTS		Young's modulus		Poisson's ratio	
	Number of specimens	Average (MPa)	Number of specimens	Average (MPa)	Number of specimens	Average (GPa)	Number of specimens	Average (-)
1. -Mafic rocks	19	124	12	12.5	8	65.2	10	0.29
2. Felsic intrusives	35	158	20	14.3	9	60.4	11	0.29
3. Felsic volcanics	8	101	6	9.1	4	58.4	5	0.25

16.2.1.5 Faults

At the scale of the property, two main fault systems are identified:

1. The Bank fault, which is associated with the D2 deformation event. The Bank fault delimits the southern flank of the Lynx mining zone.
2. The late-stage brittle faults associated with the D3 deformation event, which include the Romeo, Windfall and Northern faults. The Romeo fault is steeply dipping and striking northeast and divides the property between the Main/Underdog zones to the west and the Lynx zone to the east. The Romeo fault cuts across the Bank fault and offsets it about mid-point along the strike length of the property. The Romeo fault intersects stopes of the Bobcat and Caribou zones. It is located in the abutment of a few stopes in the Main zone. The Windfall fault is a regional-scale structure located away from the main mining areas. The Northern fault is a deposit-scale structure generally located away from the main mining areas, but it still intersects stopes in the F-zone and is close to the northern stopes of the Underdog area.



16.2.1.6 Rock Mass Jointing

The mean orientation of the interpreted joint sets is provided in Table 16-5. Joint sets were interpreted by mining zone to account for regional variation.

Table 16-5: Summary of mean joint set orientations per mining zone

Set	Lynx (dip ⁽¹⁾ /dip direction ⁽²⁾)	Main (dip ⁽¹⁾ /dip direction ⁽²⁾)	Red Dog dike (dip ⁽¹⁾ /dip direction ⁽²⁾)	Underdog (dip ⁽¹⁾ /dip direction ⁽²⁾)	Comment
J1	50 / 065	51 / 088	41 / 067	42 / 061	D1 fabric (foliation)
J2	68 / 128	61 / 139	77 / 158	60 / 130	D2 fabric (mineralization)
J3	28 / 273	45 / 244	28 / 264	36 / 271	Associated with late hydrothermal event
J4?	87 / 357	69 / 178	–	74 / 173	Local variation of J2?
J5?	09 / 089	13 / 109	14 / 088	15 / 096	Local variation of J1, J2 and J3
J6?	70 / 266	80 / 264	–	89 / 267	Local variation of J3?
J7?	–	48 / 012	–	–	Local variation of J1 or J4?

Notes:

⁽¹⁾ Dip is measured downwards from horizontal and varies between 00 (horizontal) and 90° (vertical).

⁽²⁾ Dip direction varies clockwise from north (North is 000, East is 090, South is 180 and West is 270°).

16.2.1.7 Rock Mass Classification

Rock mass quality classification was performed from geomechanical data collected from drill holes with three distinct classification methods: the Q-system (Barton et al., 1974), the GSI (Hoek, 1994; Hoek et al., 1995), and the RMR₈₉ system (Bieniawski, 1989). Rock mass quality has been assessed by mining zone to account for regional variation. All of the mining zones are classified as 'Good' quality rock masses in both the Q-system and the RMR₈₉ system.

The rock mass classification results are provided in Table 16-6 in terms of 30th and 50th percentile of the distributions. These percentiles can be considered on the conservative side.



Table 16-6: Summary of rock mass classification per mining zone

Mining zone	Q-system ⁽¹⁾		GSI		RMR system ⁽²⁾	
	30 th percentile	50 th percentile	30 th percentile	50 th percentile	30 th percentile	50 th percentile
Lynx	13	23	76	79	77	82
Main	12	16	74	77	72	76
Red Dog Dike ⁽³⁾	8	11	74	76	79	81
Underdog	12	16	72	75	73	76

Notes:

- (1) Assuming dry conditions and excluding the influence of active stresses (excluding J_w and SRF factors).
- (2) Assuming dry conditions.
- (3) The Red Dog identified as a domain during the PEA was included in the felsic intrusives lithologies in the FS, based on more advanced grouping.

16.2.2 Anticipated Rock Mass Behaviour

The anticipated rock mass behaviour can be differentiated into the following main categories:

- From surface to approximately 600 m in depth (approximately 51% of the Project tonnes):
 - Due to the low stress conditions, the rock mass behaviour will be largely structurally controlled and mainly influenced by the spacing and persistence of the natural discontinuities. The occurrence, persistence and characteristics of the major geological structures and rock mass fabric, as well as their intersections, will, for the most part, control the rock mass behaviour around the openings;
 - The ground instabilities in stopes and around development will be controlled by the relaxation of the jointed rock mass, which could result in gravity-driven wedge instabilities;
 - Due to relaxation, the dilution off the stope walls will be particularly sensitive to the length of time the stopes will remain open, and the rock mass damage originating from drilling and blasting practices;
 - Minimum to no rock mass damage due to the induced stresses is expected to occur around typical stopes in this depth range, except in sectors of lower rock mass quality.



- From 600 m to 1,100 m in depth (approximately 49% of the Project tonnes):
 - This depth range will constitute a transition between mainly relaxation-driven instabilities to stress damage-driven instabilities. With increasing depth and extraction, mining-induced stresses can be expected to concentrate around the excavations. The strength of the intact rock and healed discontinuities (like veins) will control rock mass stability;
 - Stress concentrations on sill levels, in retreat zones between converging mining fronts and in waste pillars can be expected to lead to spalling and local instabilities at these locations, as well as slippage and deformation along geological discontinuities. Seismic (and possibly rock bursting) conditions could develop in sill pillar levels and in sectors where mining fronts will converge;
 - Longitudinal mining towards a central access can be expected to be more challenging.
- Sill pillar levels:
 - Production will come from distinct mining horizons to meet production targets, which will create sill pillar levels where mining fronts will merge. The bottom-up sequence will push ground stresses upwards and concentrate them in sill pillars. Stress concentration on sill levels is anticipated to lead to spalling and local instabilities in the 600 m to 1,000 m depth range, with more intense spalling and potentially rock bursting conditions being expected below 1,000 m. Some operational challenges are likely to be encountered during the mining of sill pillar stopes at depth;
 - It is anticipated that stress related issues will mostly occur in the Lynx mining zones where the stope panels are more continuous, as compared to the Underdog mining zone where the panels are more fragmented and discontinuous;
 - Approximately 15% of the total Project tonnes will be located in sill pillar stopes.
- Bank fault:
 - The rock mass in the interpreted Bank fault corridor is expected to be of lower quality. Stopes located in and in close proximity to the Bank fault can be expected to produce higher levels of dilution.
- Other faults:
 - Areas of poor RQD associated with the Bank fault or other faults could provide conduits for water infiltration into mine workings. FLAC3D™ (Itasca, 2019) numerical simulations did not consider hydrogeological effects.



The geological settings of the deposit are quite complex and the main joint set orientations are expected to be highly variable throughout the deposit. The geometry of gravity-driven wedge instabilities is thus anticipated to vary throughout the mine. At the scale of a drift, the large variability and complexity of the rock mass jointing is anticipated to result in highly variable conditions in terms of wedge instabilities. Development crossing other known faults, such as the Romeo fault, will encounter lower rock mass quality and unraveling conditions. Other small-scale faults and geological features can also be expected to influence the rock mass behaviour locally.

16.2.3 Geomechanical Guidelines for Mine Design

The geomechanical recommendations and guidelines presented below are based on geomechanical assessments that included empirical methods (stope dimensions, dilution estimates, crown pillar dimensions) and mine-wide numerical simulations of the mining sequence with FLAC3D, an advanced explicit three-dimensional finite-difference code for continuum mechanics engineering applications.

16.2.3.1 Stope Dimensions and Dilution Estimates

Stope dimensions were first established for the individual stopes to be stable according to the empirical Stability Graph method (Mathews et al., 1981, later updated by Potvin, 1988 and Nickson, 1992, amongst others) and to have an external dilution of less than 1 m according to the equivalent linear overbreak/slough ("ELOS") empirical method (Clark, 1998). These dimensions were later tested with the numerical modelling analyses, at both the PEA and FS levels.

The following stope dimensions are recommended for the economic evaluation of the deposit:

- Vertical height between levels (floor-to-floor): 20 m; and,
- Maximum strike length (east-west): 32 m.

These recommendations apply to stopes with an undiluted horizontal width less than, or equal to, 8 m (which covers approximately 84% of the Project stopes). The majority (68%) of the stopes with an undiluted horizontal width greater than 8 m have a strike length less than, or equal to 25 m.

Following the numerical analyses – where local stress magnitudes, lithologic effects and the interaction between stopes were examined more explicitly – the empirical ELOS estimates were revised. The two main numerical assessment criteria to estimate dilution were the plastic state of the rock mass and its confinement level (minimum principal stress magnitude).



It was found that the analysis is sensitive to the plastic state threshold considered. Results obtained with two dilution parameters – whereby dilution can be triggered once the rock mass has yielded to 15% or 20% of its peak strength – were analyzed. The decision to use one criterion or the other should be based on the level of economical / financial risk the Project can tolerate, as per management guidelines. Both the 15% and 20% criteria appear reasonable, with the 20% of peak strength being more conservative than the 15% of peak strength. The 15% of peak strength criteria was retained for mine planning.

Only a very limited calibration exercise could be completed to confirm the plasticity and confinement criteria retained for these analyses, which consisted in comparing predicted and actual dilution in a test stope at L600. The modelling results showed very limited dilution in that stope, which matched field observations.

These analyses are also dependent on the pre-mining stress orientation. As more stress data and observations become available and as mining experience is gained, the pre-mining stress orientation should be confirmed. If the maximum principal stress shows evidence of being more normal to the ore body strike rather than at an angle (as the recent stress measurements at Windfall indicated), this could change these estimates.

Dilution estimates from numerical simulations are also dependent on the RQD values considered to assign rock mass strength in the FLAC3D model. The use of the RQD block model will underestimate rock mass strength if RQD values are conservative, which will lead to larger ELOS values being computed if strike lengths were left unchanged.

Importantly, the ELOS estimates represent the average depth over which stope walls in the various zones would not be self-standing based on the computer simulations once a state of equilibrium has been reached (in the “long term”). In A2GC’s opinion it is unlikely that these depths would entirely convert to actual dilution inside all the stopes if efficient mitigating measures are implemented and maintained during production, including the following:

- Good blasting techniques, in terms of design and QA/QC. In particular, blastholes accuracy will be critical as any loaded blasthole deviating into a stope wall will immediately cause significant dilution;
- Quick mining in weaker horizons, and particularly quick mucking following blasting; and,
- Prompt backfilling, to further minimize the amount of time stopes will remain open in weaker horizons.

If only 20% of the predicted dilution volume can be maintained in place (i.e., if only 80% of the predicted dilution volume actually converts into non-self-standing material), which might be achievable with top-tier mining practices, then the actual ELOS estimates used in the mine design are as shown in Table 16-7.



Table 16-7: Summary of ELOS estimates assuming the rock mass has yielded to 15% of its peak strength with a 20% control over the computed ultimate non-self-standing profiles

Mining Zone		Study Assumptions
Lynx	General values	HW = 0.5 m FW = 0.5 m
	Triple Lynx zone, between L740 and L1000, west of mine coordinates E4000 (14% of the Project stopes)	HW = 0.6 m FW = 0.6 m
	Lynx 4 zone, between L680 and L960, between mine coordinates E3755 and E3930 (7% of the Project stopes)	HW = 0.8 m FW = 0.8 m
	Lynx 4 zone, between L960 and L1100, east of mine coordinates E4000 (2% of the Project stopes)	HW = 1.0 m FW = 1.0 m
Main and Underdog	General values	HW = 0.5 m FW = 0.5 m

16.2.4 Dimension of Pillars

16.2.4.1 Waste Rib Pillars

Rib pillars are not planned to be left in place as part of the selected mining method. However, waste rib pillars could remain when the economic mineralization is not continuous. Multiple instances of waste rib pillars were observed in the proposed stope layout. Rib pillars should maintain at least a 1:1 aspect ratio, i.e., maintain the rib pillar strike length equal to, or longer than, the diluted horizontal width of the widest abutting stope. At depth, it would be preferable to systematically mine small rib pillars (with an aspect ratio of less than 1:1) to avoid stress concentration and seismicity related issues. Waste rib pillars at depth with an aspect ratio up to 2:1 may benefit from their own specific stability analyses.

16.2.4.2 Inter-Lens Pillars

A waste pillar between two parallel mineral-bearing mining lenses is defined as an “inter-lens” pillar. Mineralized lenses tend to generally be away from each other across the mining zones, but some lenses lie in close proximity, creating narrow inter-lens pillars whose stability is of concern. The following guidelines are provided based on A2GC’s experience and the insights from the numerical modelling assessments:

- It is recommended that the horizontal width of the inter-lens pillar (in the north-south direction) be at least twice the diluted horizontal width of the widest of the two lodes it will separate. It was verified in the numerical simulations that if the inter-lens pillar is thinner, it will be close to or at residual conditions; and



- If parallel veins are in closer proximity, they should be mined concurrently as a single lens, taking the waste gap along.

16.2.4.3 Crown Pillars

The minimum crown pillar vertical thickness was evaluated using empirical methods (Carter, 1992, 2014) and confirmed with the numerical modelling results, at both the PEA and FS levels. The minimum crown pillar vertical rock thickness (excluding any overburden) recommended for the economical evaluation of the Project is as follows:

1. 30 m for stopes with a diluted horizontal width less than or equal to 6 m; and,
2. 40 m for stopes with a diluted horizontal width between 6 m and 9 m.

As specified in the Québec provincial regulations concerning occupational health and safety in mines, excavations to be mined within 100 m of a water body must be subject of a detailed geotechnical and hydrogeological study before mining.

16.2.4.4 Sill Pillar Mining

The results of the geomechanical assessments suggest that stress-related problems are likely to occur during sill pillar mining, and mainly at depth in the Lynx zone where stope panels are more continuous.

The pre-mining stress conditions of each stope was assessed based on mine-scale numerical stress modelling results. The main assessment criterion was the ratio of the deviatoric stress (the $\sigma_1 - \sigma_3$ magnitude) over the unconfined compressive strength in the stope's numerical elements, normalized to the stope volume. When that ratio became greater than 0.7 (as per Cotesta et al, 2014), the zone was considered to be "highly stressed" prior to be mined. Details on this analysis are given in A2GC (2022).

Six stopes were found to be "highly stressed", and 41 stopes were found to be "moderately stressed" prior to be mined. The majority of those stopes are located in sill pillars, or in the level below a sill pillar, in the Triple Lynx and Lynx 4 mining zones, at levels L620, L740 and L860.

Stopes in the Lynx sill pillars on L620, L740, L860 and below should be "penalized" in the economics to account for the increased stress hazard (due to more difficult mining conditions being expected), either by reducing recovery (from 60% to 50%), increasing stoping cycle time (by 60-75% of the normal mining rate), and/or adding rehabilitation costs and delays. Heavier ground support is recommended for the undercut accesses located on sill pillar levels (Table 16-8).



16.2.5 Backfill Strength Requirements

The stopes will be backfilled with the following backfill types:

- Cemented rockfill ("CRF") and uncemented rockfill; and,
- Cemented paste backfill ("CPB").

CRF is planned to be used mainly in the early years until the CPB plant is commissioned later in the mine life, then to provide flexibility to backfill stopes located away from the main CPB piping system or in case of operational issues with the CPB plant.

Minimum backfill strength requirements were first estimated at the PEA stage for longitudinal mining using the equation proposed by Mitchell et al. (1982) for the design of free self-standing backfill. Additional backfill geometries and exposure dimensions referring to panelled stope situations were examined at the FS stage with various common backfill stability methods, namely the Mitchell (1982), Yu (1991) and Li & Aubertin (2012 and 2014) approaches. In all cases the exposed backfill height was 20 m, the backfill had a density of 2.2 and a friction angle of 30°, with a factor of safety of 1.5 being again considered. Based on the range of values provided by these methods, A2GC's recommendation would be to maintain in all cases (for both longitudinal and panelled stopes) a minimum UCS of 175 kPa to prevent liquefaction that can be triggered by nearby blasting or seismic events.

Note that stopes sitting immediately above sill pillar stopes will require higher backfill strength as they will be undercut during sill mining. For these stopes, the minimum UCS required should be in the 0.5 to 1.0 MPa range, depending on geometry and to be confirmed by site specific analyses.

16.2.6 Seismic Conditions

The rock mass can be expected to produce seismic conditions at depth due to the stiff, strong and brittle nature of certain lithologies. The results of the numerical modelling analyses suggest that seismic conditions could develop starting at a depth of about 620 m in sill pillar stopes, around waste pillars and in converging mining fronts, and will further increase with depth. The narrowness of the stopes will tend to keep higher stress concentrations in closer proximity to the excavations and in converging mining fronts.

Mitigating measures would include the following:

- Optimizing the sequence to cause mining-induced stress changes to occur as far away as possible from active mining areas;
- Installing dynamic ground support in seismic-prone sectors; and,
- Installing and maintaining a sufficiently sensitive and accurate microseismic monitoring system, and implementing related triggered action response plans (TARPs).



For the economical evaluation of the deposit, it is recommended to include the costing of the installation, maintenance and operation of a microseismic monitoring system that would be installed at some point in the life of mine (sometime during the first few years, so that reliable background seismic levels can be established), especially if there is a potential to extend the mine deeper than the maximum depth considered in the current Study.

16.2.7 Infrastructure Proximity Relative to Ore Body

Fixed infrastructure location was assessed based on mine-scale numerical stress modelling results. The development was not explicitly included in the simulations and therefore the modelling results do not take into account the stress redistribution due to the geometry of each underground infrastructure.

It was first verified whether the infrastructure stood within or outside the area affected by mining (from a stress change perspective). Volumes within which the maximum principal stress magnitude changed by more than 10% of its original value were considered affected by mining. For those infrastructures located inside these volumes, the main assessment criteria were the variation in deviatoric stress (the difference between the major and the minor principal stress magnitudes) and the loss of confinement. A variation in deviatoric stress of less than 10 MPa was considered acceptable, and confinement was considered sufficient when the minimum principal stress remained above 2 MPa. The infrastructures assessed include:

- Ventilation raises;
- Ramps;
- Garage at L560; and
- Central intersections (from longitudinal retreat mining sequence).

Based on the numerical modelling results and a general review of the currently planned infrastructure location, the following are observed.

- Most of the ventilation raises should be located outside the volumes affected by mining. For those few levels where the ventilation raises are within the volume affected by mining, the criteria described above should not be met and therefore the ventilation raises are not expected to be subjected to stress-induced damage;
- The ramp is located outside the volume affected by mining on all levels;
- The garage at L560 is located outside the volume affected by mining;
- A challenge related to a longitudinal retreat mining sequence is that the central intersection towards which mining retreats is increasingly affected by converging mining while still being needed until the last stope on the level is mined. A few central intersections did not meet



the assessment criteria described above. Increased ground support requirements should be planned at these locations. Extensometers should also be installed and monitored in those intersections. Rehabilitation should also be expected and planned for those intersections affected by the largest stress variations. The following levels are concerned:

- Zone 27: L220 and L240;
- Lynx (LXM): between L200 and L240;
- Triple Lynx (TLX): between L540 and L780;
- Lynx 4: between L980 and L1080.

16.2.8 Ground Support

Ground support standards have already been developed by Osisko for the underground exploration development. A review of these standards was performed by A2GC following a site visit (A2GC, 2020). Those existing standards were validated using deterministic kinematic analyses of potential unstable wedges (A2GC, 2021).

The ground support recommended for costing purposes is presented in Table 16-8 (refer to A2GC, 2021 for the accompanying notes and details). The recommendations are based on the assessments performed and A2GC's experience. The ground support needs should be reassessed when the rock mass conditions and behaviour are confirmed once mining ramps up and reaches a production steady state. Changes in ground conditions should be monitored, and ground support modified accordingly where required.

Table 16-8: Development ground support recommendations

Type of excavation	Dimensions	Back support	Wall support
Ramp, level access, ventilation access, paste, stockpiles	5.2 m wide by 5.5 m high	2.4 m long Ø20 mm, fully encapsulated resin grouted rebar on a 1.3 m × 1.2 m spacing with 6-gauge 4-inch squares galvanized welded wire mesh.	1.5 m long FS35 Splitsets on a 1.3 m × 1.2 m spacing down to 1.5 m from the floor with 6-gauge 4inch squares galvanized welded wire mesh from the shoulders down to 1.5 m from the floor.
Refuge, pump station, explosives and detonator magazines	5.2 m wide by 5.5 m high		
Access to stoping areas	4.3 m wide by 4.5 m high		
Stope overcut and undercut sill	4.0 m wide by 4.5 m high		



Type of excavation	Dimensions	Back support	Wall support
drive not in sill pillar levels			
Sump	4.5 m wide by 4.5 m high		
Stope undercut sill drive in sill pillar levels (> 600 m deep)	4.0 m to 4.3 m wide by 4.0 m to 4.3 m high	2.4 m long Ø20 mm, fully encapsulated resin grouted rebar on a 1.3 m × 1.2 m spacing with 6-gauge 4-inch squares galvanized welded wire mesh. 2.4 m long Ø20 mm, fully encapsulated resin grouted rebar added in the dice of the main bolt pattern.	2.4 m long Ø20 mm, fully encapsulated resin grouted rebar on a 1.3 m × 1.2 m spacing with 6-gauge 4-inch squares galvanized welded wire mesh from the shoulders down to 1.5 m from the floor. 1.5 m long FS35 Splitsets added in the dice of the main bolt pattern.
Electrical sub-station	7.0 m wide by 5.5 m high	2.4 m long Ø20 mm, fully-encapsulated resin grouted rebar on a 1.3 m × 1.2 m spacing with 6-gauge 4-inch squares galvanized welded wire mesh.	1.5 m long FS35 Splitsets on a 1.3 m × 1.2 m spacing down to 1.5 m from the floor with 6-gauge 4-inch squares galvanized welded wire mesh from the shoulders down to 1.5 m from the floor.
Materials bay	7.0 m wide by 5.5 m high	2.4 m long Ø20 mm, fully-encapsulated resin grouted rebar on a 1.3 m × 1.2 m spacing with 6-gauge 4-inch squares galvanized welded wire mesh. 5.0 m long Ø15.2 mm bulged cablebolts (single cable per hole) on a 2.0 m × 2.0 m spacing.	
Typical intersection	Less than 11.0 m wide	5.0 m long Ø15.2 mm bulged cablebolts (single cable per hole) on a 2.0 m × 2.0 m spacing.	–
Loading intersection in front of stockpile	Less than 11.0 m wide	6.0 m long Ø15.2 mm bulged cablebolts (single cable per hole) on a 1.8 m × 1.8 m spacing.	2.4 m long Ø20 mm, fully encapsulated resin grouted rebar on a 1.3 m × 1.2 m spacing with 6-gauge 4-inch squares galvanized welded wire mesh from the shoulders down to 1.5 m from the floor.



Type of excavation	Dimensions	Back support	Wall support
Central intersection of retreating zone	Less than 9.0 m wide	6.0 m long Ø15.2 mm bulged cablebolts (single cable per hole) on a 1.5 m × 1.5 m spacing.	–
Stope brow	–	Three rows of 5.0 m-long Ø15.2 mm bulged cablebolts (single cable per hole) on a 1.2 m × 1.2 m spacing starting at 1.0 m from the open stope brow.	–
Stope hanging wall for stopes adjacent to Bank Fault	–	–	Three rows of 4.0-m long Ø15.2 mm bulged cablebolts (single cable per hole) on a 1.5 m × 2.0 m spacing starting at 1.0 m from the open stope brow.

The ground support requirements discussed in Table 16-8 are for static conditions. As discussed, higher ground stresses potentially causing seismicity are anticipated at depth and in certain areas where mining fronts will converge, which may require dynamic ground support, i.e., ground support systems that can sustain the dynamic loading from seismic events. Dynamic ground support typically involves the substitution of dynamic bolts (e.g., PAR1, Vulcan, D-bolt) to the rebars, or the addition of these bolts to a static pattern. Heavier gauge screen may also be required, as well as zero-gauge welded mesh straps between the bolts, either longitudinally and/or vertically.

16.3 Mine Hydrogeology

The hydrogeological conditions in the vicinity of the Windfall Project site were defined based on the fieldwork conducted in 2017 and 2019 and past hydrogeological studies (Genivar, 2008; Golder, 2018; Golder, 2020a). The results of these investigations are summarized in Golder (2020). The fall 2017 investigation program consisted in the completion of packer tests (13 tests in two exploration boreholes) and the implementation of eight observation wells. These observation wells were installed in the overburden and shallow bedrock. Static water level measured during the 2019 field campaign in observation and exploration wells throughout the site ranges from 0.64 m to 14.8 m below ground surface. The 2019 field work program consisted in 42 packer tests in four exploration boreholes and water level measurement in 25 existing observation wells and 15 exploration boreholes.



The generally flat topography is marked by some creeks and lakes. Surface deposits consist of fluvio-glacial sediments (sand and gravel), glacial till resting on felsic to mafic rocks intruded by granitoids and subvertical dikes, which are associated with the gold mineralization. Those geological formations are intersected by a complex network of brittle-ductile subvertical structures including Windfall and Romeo faults, directed NNE, and Bank fault related to the Maséres NE shear zone. Following the documentary review and hydrogeological characterization of the Windfall Project Mine Site, a hydrogeological conceptual model has been developed by Golder. Four hydrostratigraphic units have been identified.

16.3.1 Hydrostratigraphic Unit and Groundwater Flow Conditions

16.3.1.1 Fluvio-glacial Deposits (Esker)

It consists of sand and gravel lying in the northern part of the site and which thickness varies from 1 m to 25 m. The hydraulic conductivity of this unit varies between 2×10^{-6} m/s and 7×10^{-4} m/s with a geometric mean of 7×10^{-5} m/s (based on 16 hydraulic tests results).

16.3.1.2 Till

It is a heterogeneous glacial unit encountered just above the bedrock contact. A hydraulic conductivity of 3×10^{-7} m/s was measured at a single location. Considering the heterogeneous nature of this material, a hydraulic conductivity in the 10^{-5} m/s and 10^{-7} m/s range is expected for this unit.

16.3.1.3 Bedrock

It consists of basaltic flows and volcanoclastic rocks. The bedrock is mostly found below the till or fluvioglacial sediment layer.

A total of 92 hydraulic tests were conducted on the bedrock unit including slug test, packer test (maximum depth tested depth of 400 m) and pumping test. From these, hydraulic conductivity of bedrock was measured at values between 4×10^{-10} m/s and 2×10^{-5} m/s with a geometric mean of 1×10^{-7} m/s.

The 36 hydraulic tests carried out in the upper bedrock in the observation wells indicate hydraulic conductivity values between 2×10^{-9} and 1×10^{-5} m/s. The geometric mean of hydraulic conductivity value is 2×10^{-7} m/s.



Based on the distribution of hydraulic conductivity with depths presented in the Golder (2018) report and on the groundwater flow model calibration, a hydraulic conductivity of 1×10^{-7} m/s was assigned to the upper bedrock (up to an elevation of 370 m), and 7×10^{-9} m/s for deep bedrock. A lower hydraulic conductivity was assigned to deep bedrock because, according to Stober and Bucker (2007), bedrock hydraulic conductivity of Precambrian rock of the Canadian Shield tends to decrease with depth.

16.3.1.4 Structural Elements (Faults)

Osisko provided a file that contains the main faults identified in the area of the Windfall Project. These faults were included in the groundwater flow model used to estimate groundwater inflow into the mine as discrete fracture (Section 16.3.2). A hydraulic conductivity value of 7×10^{-8} m/s was assigned to the faults following the calibration of the groundwater flow model based on the annual mean dewatering rate of the actual exploration ramp ($1,100 \text{ m}^3/\text{d}$) measured by Osisko in 2021.

16.3.1.5 Groundwater Level

Measured groundwater levels were generally close to the ground surface with depth ranging from 0.84 m to 14.63 m in July 2021. Topography generally controls the groundwater flow directions. Hydraulic gradients range from 0.016 m/m to the southeast in the southern area of the impermeabilized waste rock pile to 0.02 m/m to the northwest in the direction of the lake at the foot of the esker.

Using the Darcy's law equation and the previous information on bedrock hydraulic conductivities, and a 0.01 effective porosity, the estimated groundwater flow speed would be around 0.017 m/d for the upper part of the bedrock.

16.3.2 Groundwater Inflow Estimation

A groundwater flow model (FEFLOW version 7.4) was developed by Golder (2020a) for the initial purpose of estimating groundwater inflow into the exploration ramp. The same model was used to estimate groundwater inflow into underground mine workings based on the mine plan provided on February 24, 2021, assuming that 10% of stopes will be backfilled with waste rock and the rest with paste backfill. The groundwater flow model was calibrated against water level measurements made from 27 observation wells and on the dewatering rate of the actual exploration ramp (measured flow rate of $1,100 \text{ m}^3/\text{d}$ in 2021 (Mean annual value), calculated flow rate of $1,050 \text{ m}^3/\text{d}$ obtained with the model).



Predictive simulations were performed to assess the rate of water infiltration in the exploration ramp and its proposed extension in steady state. The initial conditions of the model consider that the dewatering is already effective in the exploration ramp. Groundwater inflow was evaluated according to two cases, namely:

- Base case, which considers the calibrated parameters. The base case considers the average values of hydraulic conductivity for the rock;
- Upper range, which considers a hydraulic conductivity in the faults higher than for the base case (5×10^{-7} m/s instead of 7×10^{-8} m/s).

The results obtained show that the groundwater inflows in the workings and galleries would be between 3,860 m³/d (base case – Table 16-9) and 4,570 m³/d (upper range – Table 16-10) at the end of the operation of the underground mine.

Table 16-9: Groundwater infiltration in mine openings – Baseline scenario

Year	GW inflow
1	1,775 m ³ /d
3	2,400 m ³ /d
5	2,850 m ³ /d
7	3,230 m ³ /d
9	3,630 m ³ /d
11	3,860 m ³ /d

Table 16-10: Groundwater infiltration in mine openings – Upper range

Year	GW inflow
1	2,200 m ³ /d
3	2,925 m ³ /d
5	3,455 m ³ /d
7	3,920 m ³ /d
9	4,360 m ³ /d
11	4,570 m ³ /d

It is recommended to continue to monitor the dewatering rate from the exploration ramp during its development and exploration drilling work and update the groundwater flow model periodically.



16.3.3 Extent of Potential Drawdown

The extent of the potential area of groundwater drawdown caused by dewatering operations for the baseline scenario was evaluated. These drawdowns are obtained by comparing the water table according to the conditions of the 2017 reference state with the water table obtained under final operating conditions. The main observations made from these modelling results are as follows:

- In the area of Zone 27 and Underdog, the potential drawdown greater than 1 m of the groundwater table extends over a maximum length of approximately 300 m in a northwest/southeast direction and of approximately 150 m in a northeast/southwest direction;
- In the Lynx and Triple-Lynx region, the potential drawdown of the water table greater than 1 m extends over a maximum length of about 1,600 m in a northeast/southwest direction and of about 850 m in northwest/southeast direction;
- Drawdowns greater than 1 m, i.e., on the order of seasonal fluctuations generally observed in Québec, do not reach the supply wells located in the mining camp sector south of the ramps sector and should not cause any loss of use; and,
- The potential drawdown zone of 1 m does not reach the surrounding lakes.

16.4 Proposed Mining Method

The Windfall Project contains mineralized zones varying in dip and thickness both along strike and at depth. All geometries are suitably extracted using the Longitudinal Longhole Stopping method.

16.4.1 Longitudinal Longhole with Backfill

Longitudinal longhole mining is suitable for the Windfall Project, where the dip of the mineralization is 45° or greater, and the materialized zones are of sufficient width and grade that the estimated dilution does not eliminate the profitable recovery of the material. Mining will consist of an undercut level and an overcut level, each accessed from the main ramp or an access drift. Each sill will be accessed perpendicularly from the ramp or access drift, and then developed along strike of the vein to the economic extents of the mineralization.

Once sill development is completed on each level, production holes are drilled between the sills and then blasted until the stopping panel is completed. Following cavity monitoring of the stope, the void is then prepared for backfill. Once a sufficient distance along strike (one to two stope lengths) has been extracted and backfilled, mining can progress either up-dip or down-dip and extraction can recommence opening another mining location. A production layout example for a mining block is illustrated in Figure 16-1.

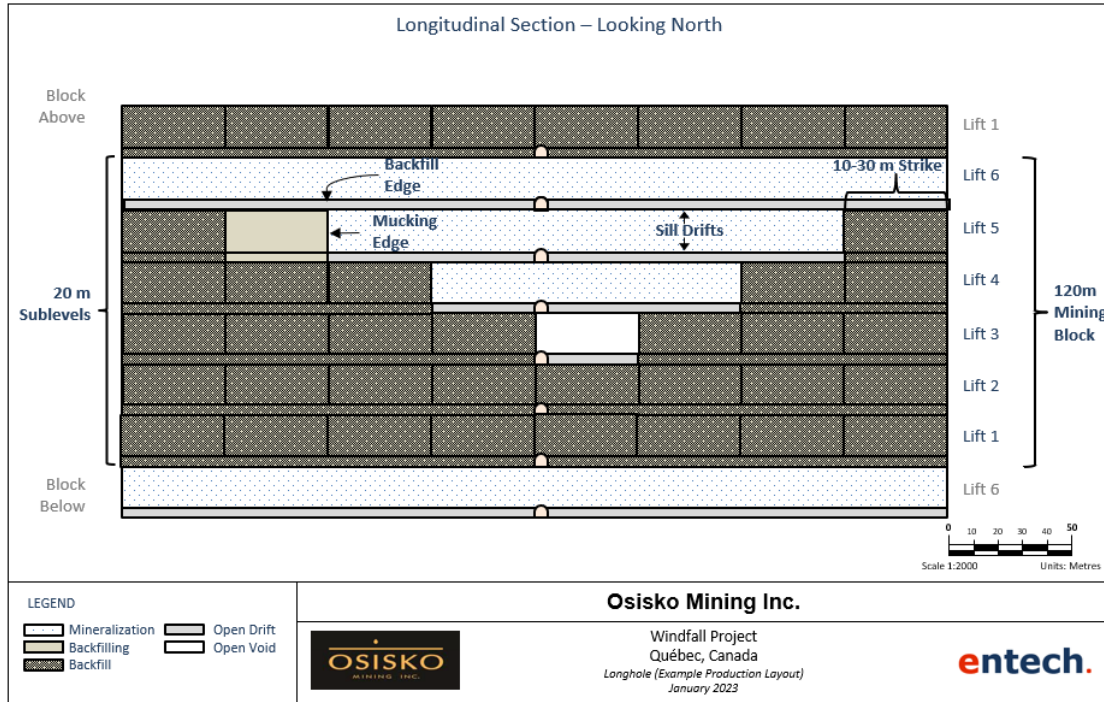

Figure 16-1: Production layout example

Stope heights of 20 m were selected based on the expected vertical continuity of the mineralization. Stope heights are measured from the floor of the undercut to the floor of the overcut level. Stope lengths are based on geotechnical guidance as outlined in Section 16.2. A maximum panel length of 30 m for stope heights of 20 m has been established before being backfilled.

16.5 Underground Mining

16.5.1 Stope Design Methodology

Preliminary stope shapes were created using Datamine® Stope Optimiser (MSO) and considered various stope heights, widths, and cut-offs during the assessment. Preliminary shapes were assessed over 5 m sections and were used to guide the design of final shapes up to a maximum length of 30 m.

A minimum horizontal mining width of 3.0 m was applied, which is based on a minimum vein width of 2.0 m plus a minimum allowance of 0.5 m of unplanned dilution on both the hanging wall and foot wall. Although drill and blast techniques can mine narrower than this width, a larger width



was deemed prudent allowing Operations the opportunity for improvement as knowledge of the mineralization is gained. A total of 25 stopes (1.3%) were wider than 15 m; these stopes were panelled along strike to reduce width and minimize ground instability and production mucking difficulties; additional dilution was assigned to these stopes.

Geotechnical investigations recommended that a crown pillar of 30 m be maintained for stopes less than 6 m diluted width, and 40 m for stopes greater than 6 m diluted width. All stopes inside the crown pillar have been removed from the mining plan or have had their height reduced based on these criteria.

Based on preliminary mining costs, a break-even cut-off grade ("COG") of 3.50 g/t Au was used for the preliminary stope optimization.

All parameters used in the creation of MSO shapes are summarized in Table 16-11.

Table 16-11: MSO Parameters

MSO Parameter	Unit	Value
Default Density	t/m ³	2.80
Default Dip	Degree	Varies by zone
Default Strike	Degree	0
Cut-off Grade	g/t	3.5
Rotation Relative to Axis		Same as model
Stope Length - Sections (U)	m	5
Stope Height - Levels (V)	m	20
Slice Interval (increment to width)	m	0.25
Stope Width Min (MMW) and Stope Width Max	m	2 to 100
Dilution - near/far	m	0.5 / 0.5
Minimum Pillar between Parallel Stopes	m	10
Stope Dip Angles - Min and Max	Degree	45 to 135
Maximum Change	Degree	5
Stope Strike Angle – Min and Max	Degree	-45 to 45
Maximum Change	Degree	5
Maximum Stope Thickness Ratio		
Top to Bottom		20
Left to Right		20



Once the stopes were generated and mining locations identified, an economic analysis was completed to identify which production shapes were likely to be economic and were to be included in the schedule using Deswik's Interactive Scheduler®.

16.5.2 Dilution and Mining Recovery

For the Study, dilution has been estimated using a combination of planned dilution and unplanned dilution. An example of dilution and underbreak is illustrated below in Figure 16-2.

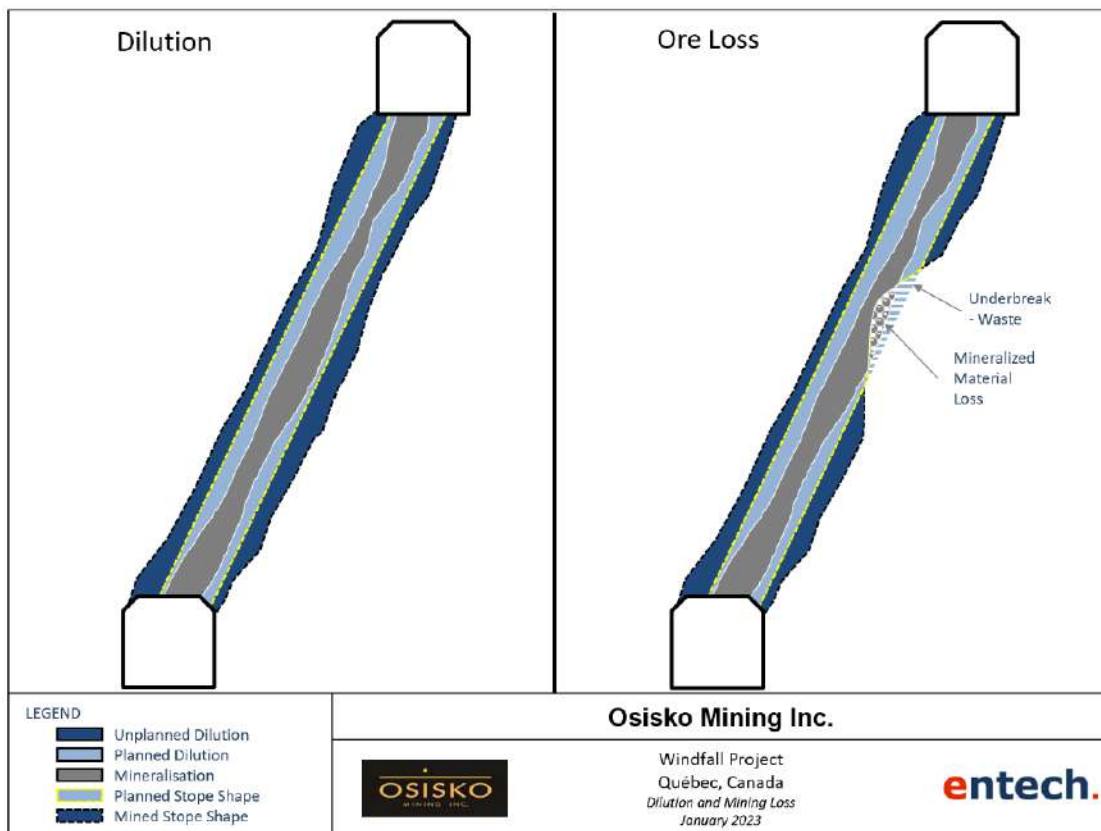

Figure 16-2: Dilution and mining recovery

Table 16-12 summarizes unplanned rock and paste dilution by mining method. Development dilution is based on actual dilution experienced at Windfall, while stope dilution is based on recommendations from A2GC (dilution calibration parameter = 0.15) as described in Section 16.2.3.1.



Table 16-12: Dilution factors

Mining Method	Mining Zone	Unplanned Rock Dilution
Development	All Zones	12%
Stoping	General for Main, Lynx and Underdog	1.0 m ELOS (0.5 m HW, 0.5 m FW)
	Triple Lynx zone, between L740 and L1000, west of mine coordinates E4000 (14% of the Project stopes)	1.2 m ELOS (0.6 m HW, 0.6 m FW)
	Lynx 4 zone, between L680 and L960, between mine coordinates E3755 and E3930 (7% of the Project stopes)	1.6 m ELOS (0.8 m HW, 0.8 m FW)
	Lynx 4 zone, between L960 and L1100, east of mine coordinates E4000 (2% of the Project stopes)	2.0 m ELOS (1.0 m HW, 1.0 m FW)
Backfill	All Zones	0.25 m for each exposed backfill wall 0.3 m for Pastefill floor

The average unplanned dilution due to ELOS for stoping is approximately 20% when compared against the final mined shape.

The average total dilution for stoping is estimated at 80%. Dilution is material that falls below the incremental cut-off grade (2.5 g/t Au) that has been included in the proposed mine plan. When warranted, an additional 5% mining dilution was added (due to poor stope geometries) and is included in the values above.

Longitudinal section views of the mine design showing the unplanned dilution and total dilution are illustrated in Figure 16-3 and Figure 16-4.

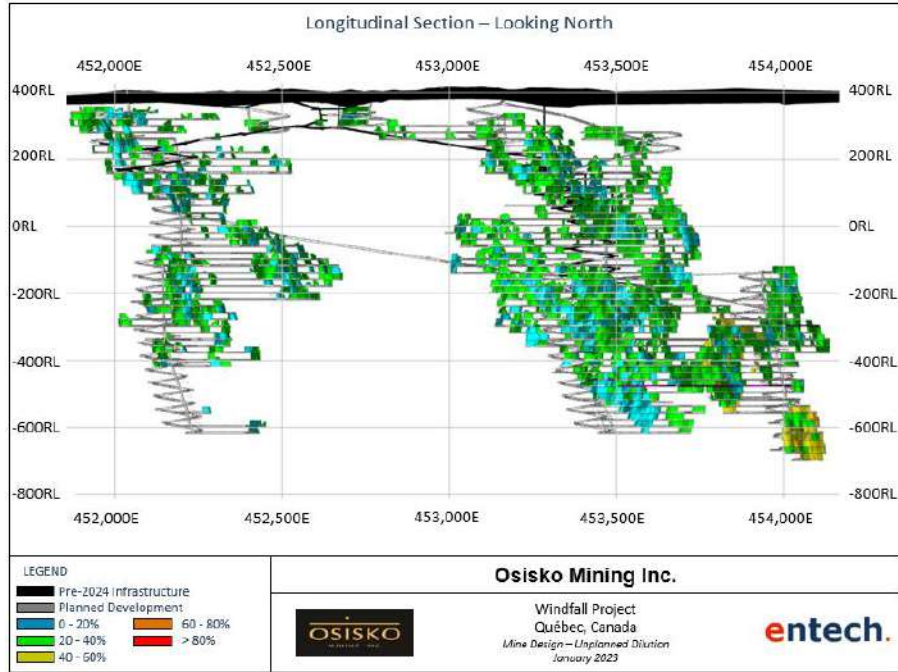

Figure 16-3: Estimated unplanned dilution (%)

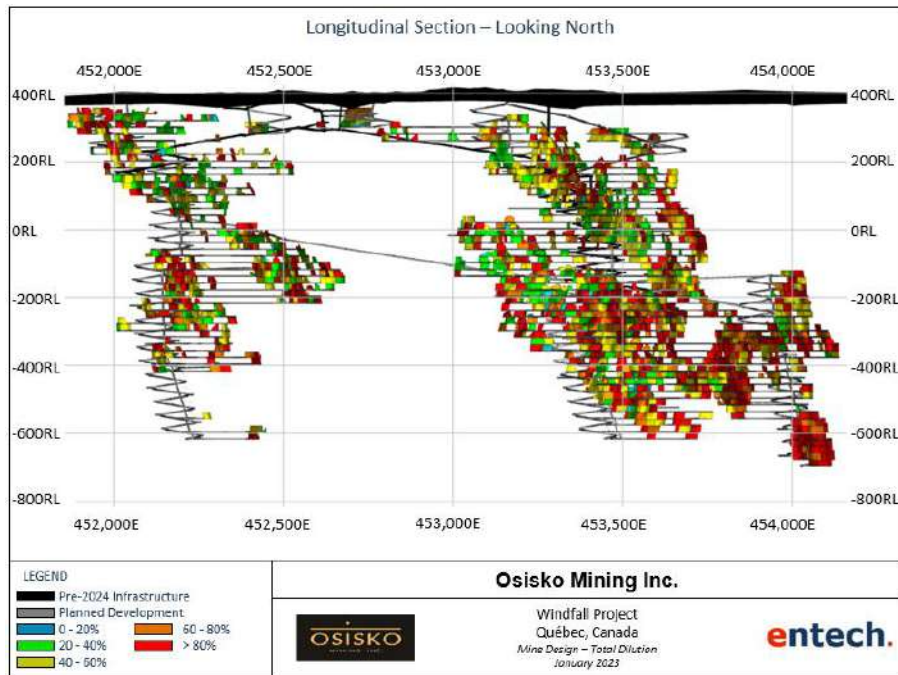

Figure 16-4: Estimated total dilution (%)



Assumed mining recoveries are 98% for development, 92% for stopes with an overcut and undercut, and 85% for stopes with an undercut only. Additional ore loss was accounted for stopes that were modeled to be in moderate or high stress conditions prior to mining. A mining recovery of 60% was considered for moderate stress and 50% for high stress. A total of 48 stopes were affected.

A longitudinal section view of the mine design showing the mining recovery is illustrated in Figure 16-5.

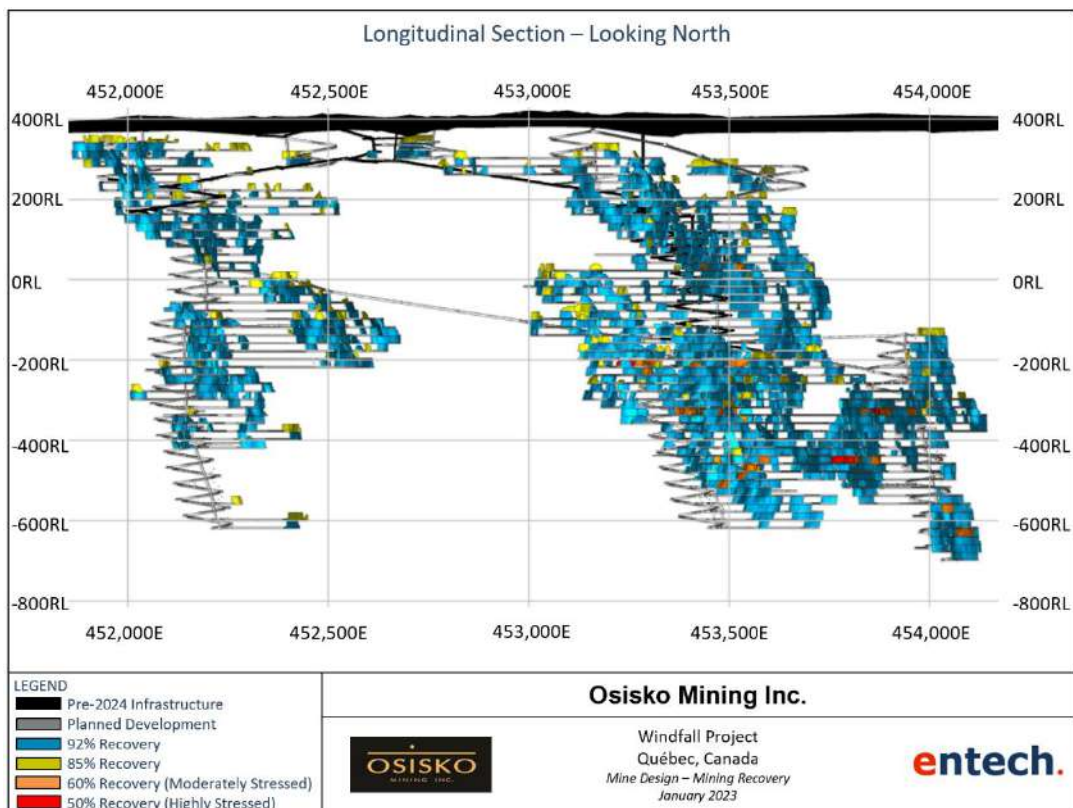

Figure 16-5: Mining recovery (%)

16.6 Development

The Windfall Project has existing underground infrastructure based on current exploration activities, with development planned and budgeted into early 2024.

The Windfall Project has three primary zones: Lynx (Lynx zone), Main and Underdog (Main zone). All zones trend roughly east-northeast and dip vertically between 45° to 90°. The Main zone is the western portion of the planned mining area and the Lynx zone is the eastern portion. The zones are accessed by three ramp systems, with two surface portals for transportation and material haulage.



The ramps and level accesses (up to the vent raise access) will be 5.2 m high by 5.5 m wide allowing the passage of 54 t haulage trucks as well as secondary ventilation ducting and service piping. Ore access drives towards the ore zone will be 4.5 m high by 4.3 m wide, while development in mineralized material will be 4.5 m high by 4.0 m wide. A summary of the various development profiles considered in the design are found in Table 16-13.

Table 16-13: Development profiles

Development Type	Width (m)	Height (m)
Ramp	5.2	5.5
Level Access	5.2	5.5
Sump	4.5	4.5
Stockpile	5.2	5.5
Electrical Station	7.0	5.5
Return Air Access	5.2	5.5
Return Air Raise	5.0 - 6.0	-
Paste Access	4.3	4.5
Ore Sill Access	4.3	4.5
Sill Drives	4.0	4.5

Figure 16-6 illustrates the proposed development for the Windfall Project along with existing exploration drives, broken down into the two principal mining zones.

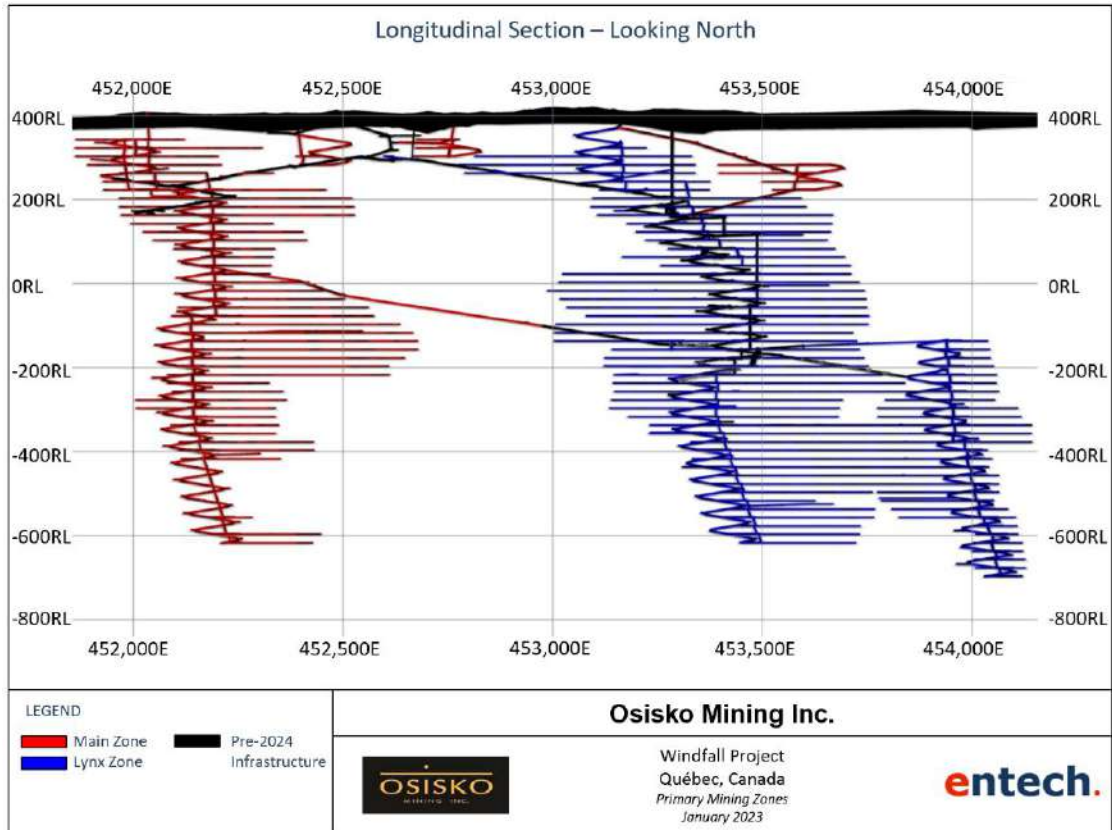

Figure 16-6: Windfall development design

16.6.1 Lynx Zone

The Lynx zone is located on the eastern side of the deposit and is an amalgamation of four smaller zones: Bobcat, Lynx 4-HW, Lynx Main and Triple Lynx. The Lynx zone extends from surface at 390 mRL down to -700 mRL on 52 levels spaced 20 m apart. A total of 108 km of lateral development is scheduled in Lynx and total stope production is estimated to be 7.2 Mt.

Maximum annual ore and waste totals over the life of mine are estimated to be 1,145 kt and 770 kt respectively, while average annual ore and waste totals over full production years (2026-2034) are 890 kt and 385 kt respectively.

A longitudinal view with the ramp, levels and zones can be seen in Figure 16-7.

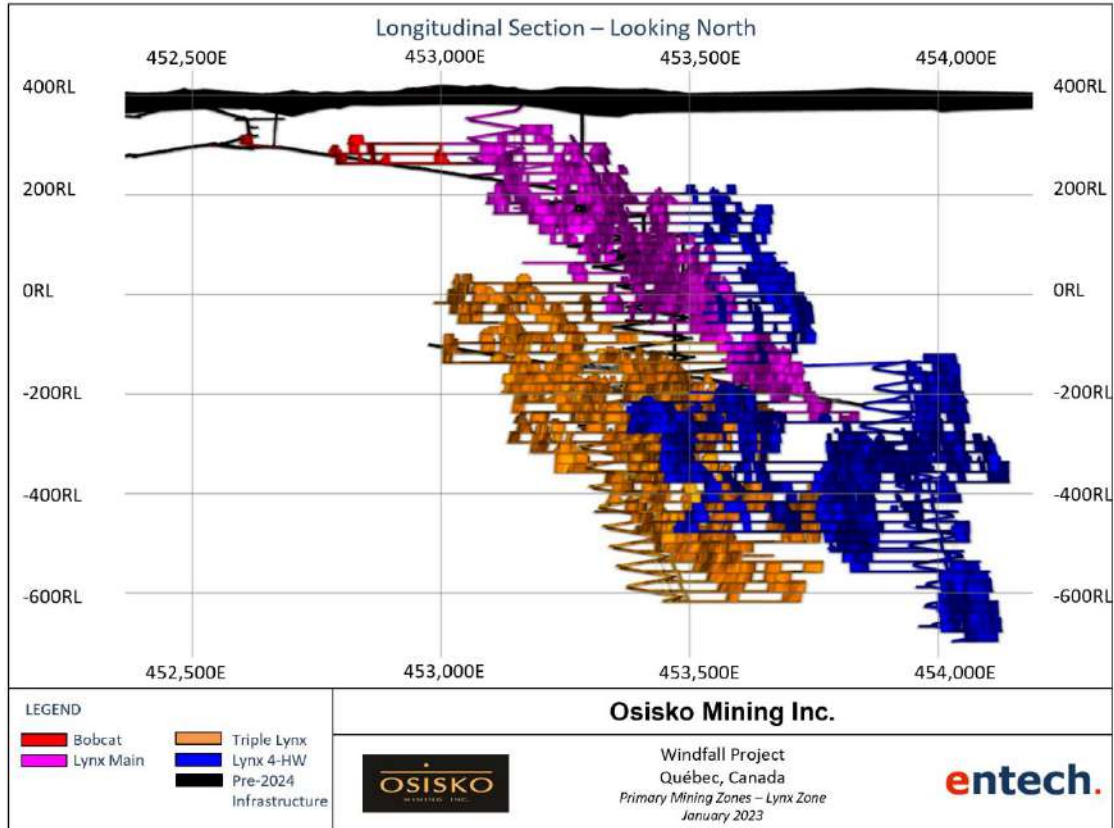

Figure 16-7: Lynx zone development design

The Lynx zone contains two primary ramp systems that share infrastructure above -177 mRL. The shared central ramp has been completed from 235 mRL to -240 mRL with plans and budget in place (approved by Osisko's Board of Directors) to complete down to -390 mRL before commencement of the project construction. The central Lynx ramp provides access to the Lynx Main and Triple Lynx zones down to -620 mRL. The central ramp will connect to the eastern ramp at -220 mRL and through a ventilation drift at the top of the east ramp. The eastern ramp provides access to the Lynx 4 zone down to -700 mRL. A new portal will also be developed in the Lynx zone.

16.6.2 Main Zone

The Main zone is located on the western side of the deposit and is an amalgamation of five smaller zones: Caribou, Zone 27, Mallard, F-zone and Underdog. It extends from surface at 410 mRL down to -618 mRL with mineralization accessed by 42 levels spaced 20 m apart. A total of 69 km of lateral development is scheduled in Main and total stope production is estimated to be 2.5 Mt.



Maximum annual ore and waste totals over the life of mine are 860 kt and 730 kt respectively, while average annual ore and waste totals over full production years (2028-2034) are 400 kt and 470 kt respectively.

A longitudinal view with the ramp, levels and zones is illustrated in Figure 16-8.

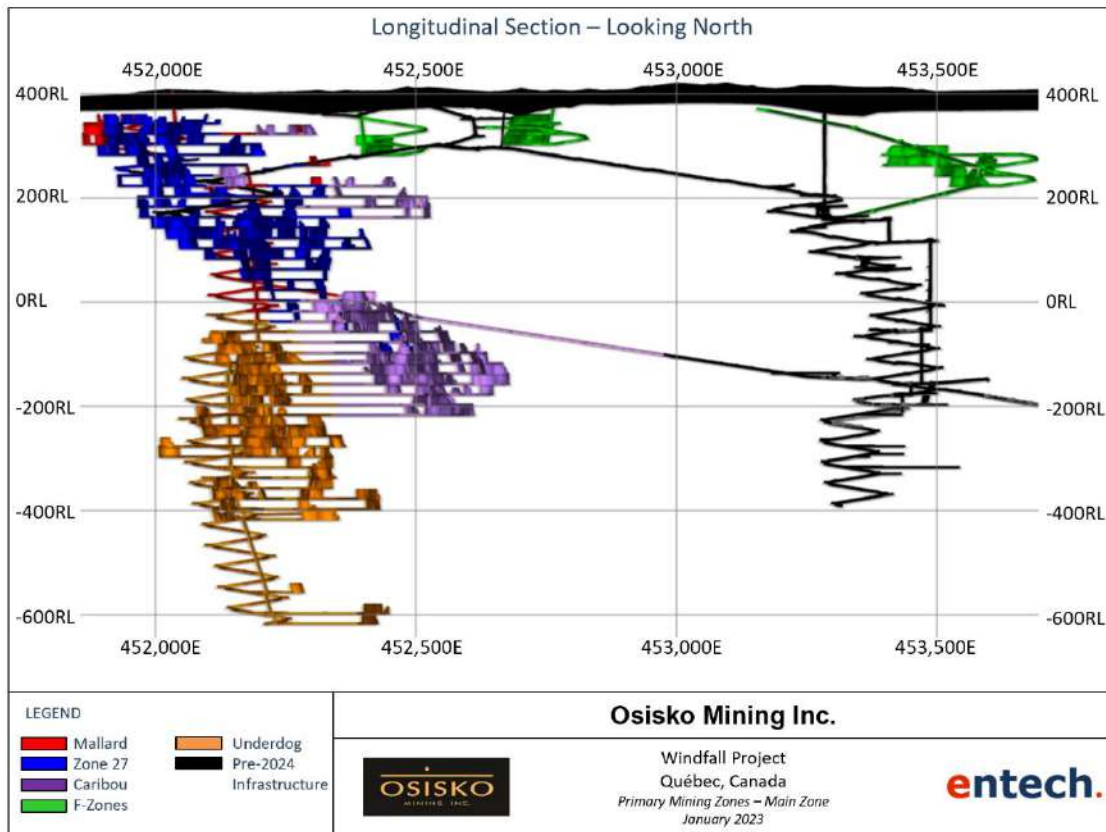

Figure 16-8: Main zone development design

The Main zone has an existing ramp from surface to 165 mRL, providing access to the Main zone from 250 mRL down to 205 mRL. The Project's planned ramp system extends from the existing ramp at 205 mRL to the bottom of the Underdog zone at -618 mRL and extends up from current infrastructure at 250 mRL to the top of the Main zone at 360 mRL. Three internal ramps above 200 mRL will be developed to access the F-zone satellite areas (FZ11, FZ17 and FZ51).



16.6.3 Primary Infrastructure

The primary infrastructure for the Windfall Project includes a garage and its components, fuel bay, refuge stations, explosive magazines, material bays and pumping stations.

Lynx and Main zones are connected near surface by existing infrastructure and through a bypass at 30 mRL on the western (Main zone) side to -140 mRL on the eastern (Lynx zone) side.

Figure 16-9 illustrates the ramp systems and shared infrastructure of the mine.

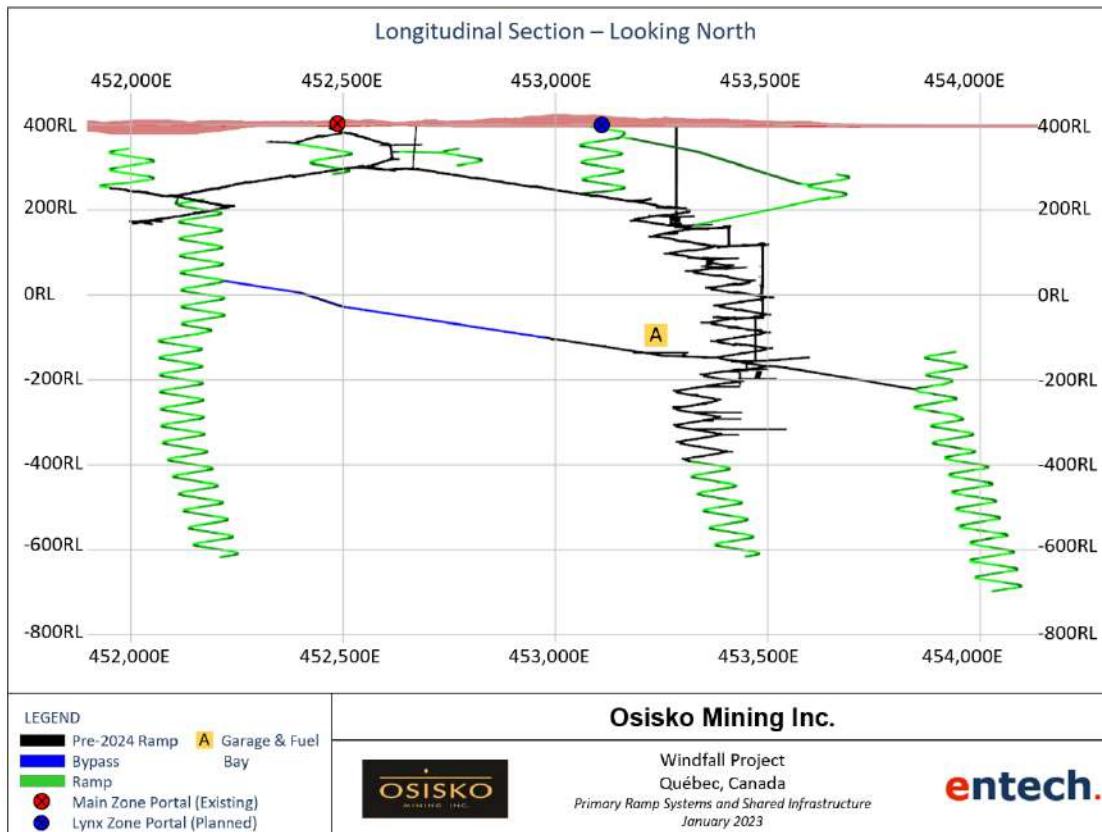

Figure 16-9: Primary ramp systems and shared infrastructure



The garage is located on the Lynx zone side of the bypass at -140 mRL. It is accessible by the Lynx zone ramp and from the Main zone via the bypass. The garage includes a mechanical bay able to accommodate 6-8 units, welding bay, oil bay, wash bay, warehouse, tire bay, electrical bay, and refuge station. The nearby fuel bay will have a fuel line from surface to facilitate underground fueling of diesel equipment. The lateral development for the garage and fuel bay is planned and budgeted for completion ahead of the commencement of the project construction, while material procurement for the garage is planned and budgeted for partial completion.

16.6.4 Production Level Infrastructure

The development design for level infrastructure follows the geotechnical recommendations for minimum stand-off required to the mineralized zone to minimise the potential for stress-induced damage to infrastructure from seismicity and production blasting activities.

Planned production level development includes the following:

- a) Access drifts;
- b) Sumps;
- c) Electrical substations;
- d) Stockpiles;
- e) Ventilation access (return airway and escapeway);
- f) Paste access (reticulation);
- g) Sills (development on mineralization); and
- h) Operating waste development (sills mining material below cut-off).

A typical level layout as well as the typical truck loading arrangement are illustrated in Figure 16-10 and Figure 16-11, respectively.

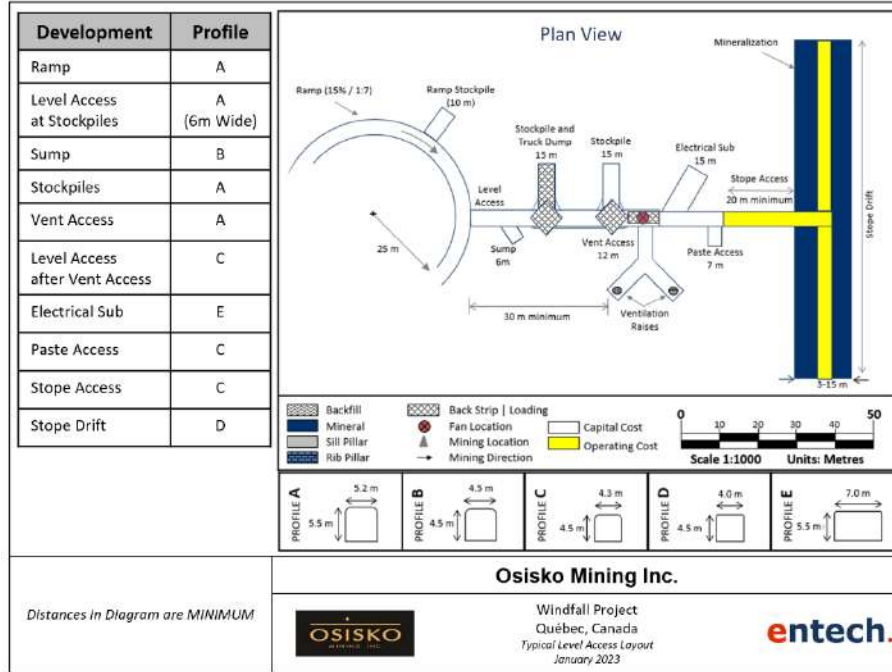

Figure 16-10: Typical level layout

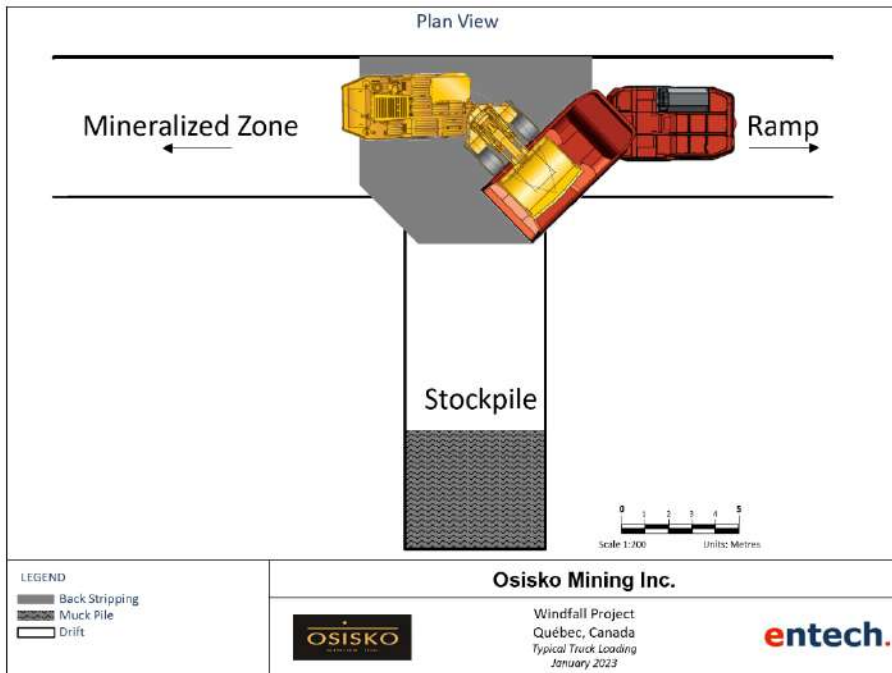

Figure 16-11: Typical level truck loading arrangement



16.7 Development and Infrastructure

16.7.1 Development Schedule

The proposed lateral development schedule for Windfall has been established using performances of 10 m per day per crew, with a maximum advance of 2 m per day for ore drives, 4 m per day for priority ramp headings and 3 m per day for all other headings. Additionally, a limit of 10 m per day has been applied to each level. Up to five crews will be needed during the life of the Project.

Vertical development over 30 m will be completed using a raise boring machine, owned and operated by a contractor. Vertical development of less than 30 m will be completed through longhole drop raise methods using production drills.

Early pre-production development focuses on the establishment of level accesses and their related infrastructure, garage infrastructure, diamond drill headings, and priority level ore drives within the existing Lynx central ramp and Lynx 4-HW down ramp.

A proposed diamond drill program to bring all material into the Measured resource category has been incorporated into the schedule, using a maximum of six diamond drills, operating at 60 m/d. Ore drive development within lenses being tested were prevented from starting until drilling for that setup is complete.

Production begins in mid 2025 and reaches the target production rate of 3,400 tpd in early 2029; milling throughput is maintained at approximately 3,400tpd until 2029 using the early mine stockpile. The Lynx zone is active at Project start, while the Main zone does not begin development until mid-2026. Longhole stoping provides approximately 80% of the total production with the remainder comprised of sill development.

Annual advance totals can be found by zone in Table 16-14 and by type in Table 16-15.



Table 16-14: Development schedule

Development Type	Unit	Development Advance												Total
		2024	2025	2026	2027	2028	2029	2030	2031	2032	2033	2034	2035	
Lynx Lateral CAPEX	km	6.5	6.5	6.6	4.1	4.6	4.6	4.2	3.4	1.4	0.0	0.0	0.0	42.0
Lynx Lateral OPEX	km	3.3	11.4	8.6	9.7	6.3	6.3	8.1	7.0	3.9	1.1	0.0	0.0	65.7
Lynx Vertical CAPEX	km	0.0	0.3	0.2	0.0	0.1	0.1	0.2	0.1	0.1	0.0	0.0	0.0	1.1
Main Lateral CAPEX	km	0.1	0.0	2.5	1.9	3.6	3.0	3.9	4.7	7.1	7.7	4.0	0.0	38.5
Main Lateral OPEX	km	0.0	0.0	0.1	2.2	3.4	4.1	1.8	2.9	5.1	6.1	3.6	0.0	29.4
Main Vertical CAPEX	km	0.0	0.0	0.0	0.2	0.2	0.1	0.1	0.1	0.1	0.2	0.3	0.0	1.3
Total Lateral CAPEX	km	6.5	6.5	9.1	6.0	8.2	7.6	8.2	8.1	8.5	7.7	4.0	0.0	80.5
Total Lateral OPEX	km	3.3	11.4	8.7	12.0	9.8	10.4	9.8	9.9	9.0	7.1	3.6	0.0	95.1
Total Lateral	km	9.8	18.0	17.8	18.0	18.0	18.0	18.0	18.0	17.6	14.9	7.6	0.0	175.6
Total Vertical	km	0.0	0.3	0.2	0.2	0.3	0.2	0.3	0.2	0.2	0.2	0.3	0.0	2.3



Table 16-15: Development metres per type per year

Development Type	Unit	2024	2025	2026	2027	2028	2029	2030	2031	2032	2033	2034	2035	Total
Ramp	km	0.7	1.5	2.4	1.0	1.8	1.2	1.4	1.3	1.9	2.2	0.6	0.0	16.1
Level access and infrastructure - CAPEX	km	4.6	3.9	5.6	2.5	3.7	4.0	3.3	4.1	2.7	2.9	1.6	0.0	39.0
Ore Drive - CAPEX Waste	km	1.3	1.2	1.3	2.5	2.8	2.5	3.4	2.8	3.9	2.8	1.8	0.0	26.3
Ore Drive - OPEX Ore	km	3.2	11.3	8.5	11.8	9.5	10.2	9.7	9.8	8.9	6.9	3.6	0.0	93.4
Vertical Development	km	0.0	0.3	0.2	0.2	0.3	0.2	0.3	0.2	0.2	0.2	0.3	0.0	2.3



16.8 Production

16.8.1 Stope Physicals

Table 16-16 summarizes the final economic, diluted, and recovered stope metrics from the stope design process for the Windfall Project.

Table 16-16: Economic stope metrics

Item	Unit	Lynx Zone	Main Zone	Total Windfall Project
Diluted tonnage	† ('000s)	7,200	2,500	9,700
Au Diluted grade	g/t	8.89	5.99	8.12
Ag Diluted grade	g/t	4.55	3.14	4.19
Minimum width	m	3.0	3.0	3.0
Average width	m	5.8	4.4	5.4
Average length	m	25	25	25
Average tonnage	† ('000s)	5,200	4,500	5,000

Based on material within the Feasibility mining plan, the overall Mineral Reserve ounces per vertical metre is 2,860. Figure 16-12 illustrates the ounces per vertical metre in 40 m increments.

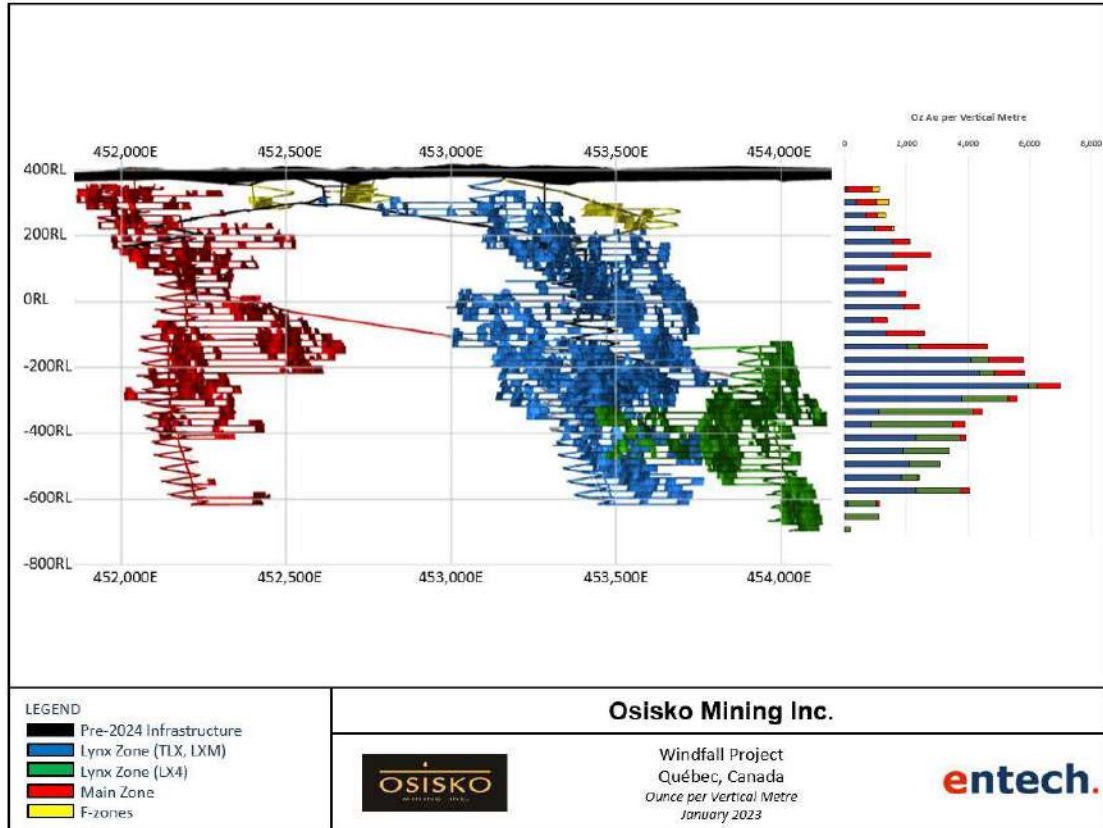

Figure 16-12: Mineral Reserve Ounces per Vertical Metre

16.8.2 Longhole Drilling

Longhole drilling productivity has been scheduled using varying rates depending on the activity. Each stope will have a slot raise composed of drill holes surrounding a 30-inch V30 raise bore, in addition to the stope drill pattern. The mine schedule averages 600 m per day of production drilling, at an average drill factor of 4.7 t/m drilled, which includes a 10% re-drill allowance. Production drilling designs were created for both downhole and uphole options for stope widths varying from 2 – 15 m. Narrow stopes (<5 m width) were designed with a zipper or dice drill pattern while stopes with width >5 m were designed with complete rings. These designs used 3-inch diameter production drill holes with a hole burden between rings of 1.9 m and a toe spacing between 2.0-2.5 m. Adjusted burden/spacing was used for narrow stopes using the zipper drill pattern.



Example production drilling designs for downhole and uphole stopes can be seen in Figure 16-13 and Figure 16-14 respectively. Production drills are assumed to utilize semi-autonomous capabilities allowing remote hole completion at end of shift. The daily rates for drill and blast activities can be seen in Table 16-17.

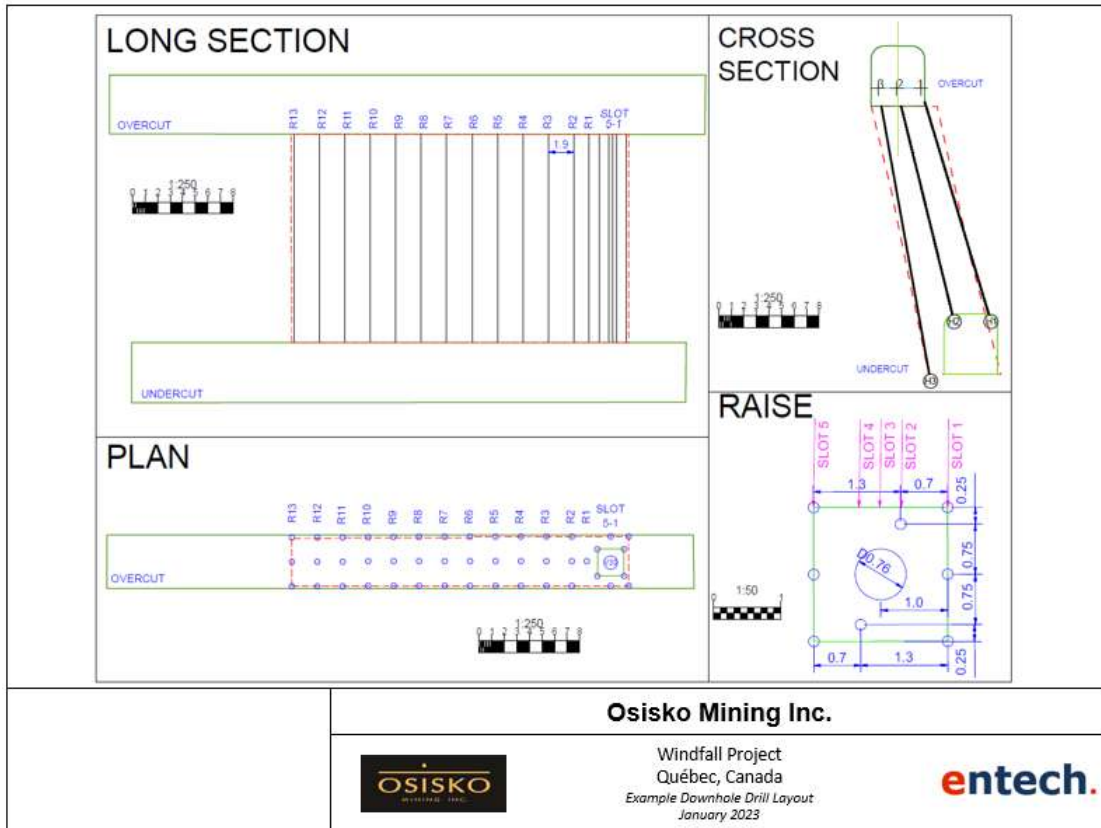

Figure 16-13: General arrangement for downhole stope design

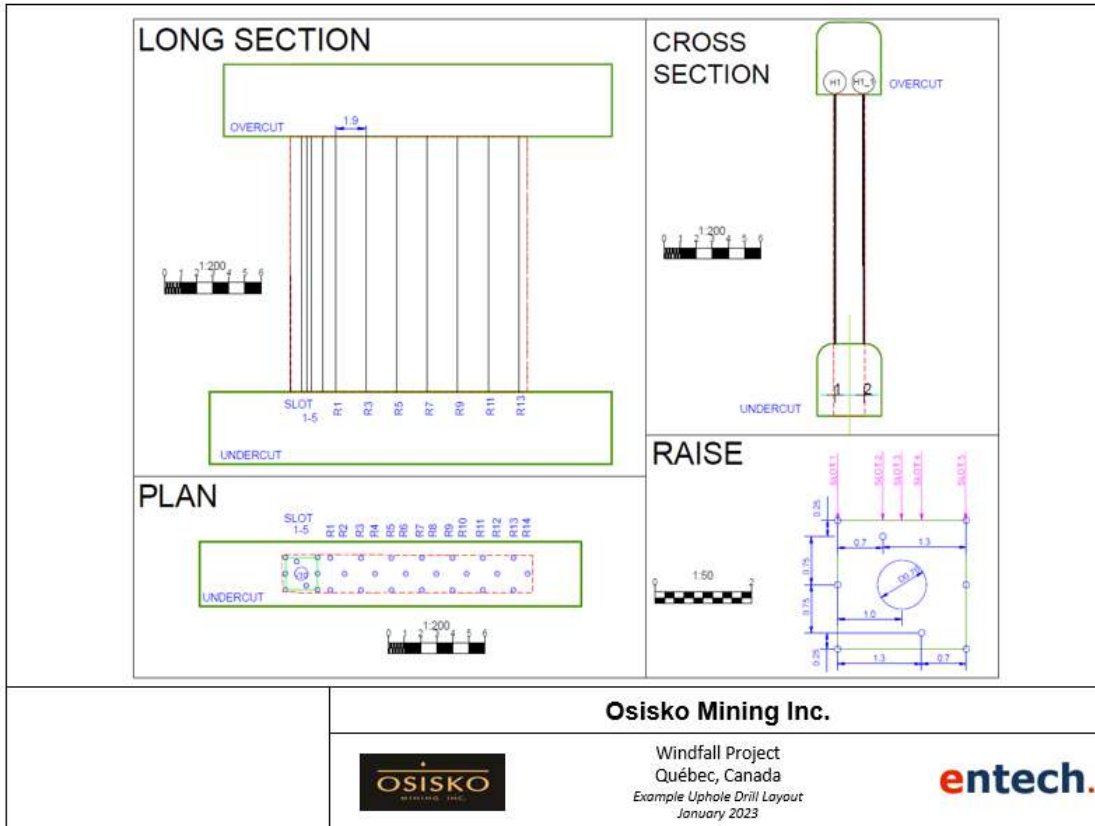

Figure 16-14: General arrangement for uphole stope design

Table 16-17: Drill and blast daily rates

Task	Rate	Duration
V30 Slot Raise	-	2 d
Production Drilling	200 m/d	-
Production Cable Bolts	-	0.5 d
Load and Blast, Void Mucking	-	2 d

16.8.3 Material Movement

The main accesses have been designed with two 15 m stockpiles per level, with many ore drives available that can serve as temporary stockpiles. During development, all larger profile headings will utilize the 18 t LHDs, while smaller profile headings will utilize the 14 t LHDs. During production, stopes will be mucked to the level access stockpiles using 14 t LHDs. Once the stockpiles are full,



a dedicated 18 t LHD will conventionally load trucks until the stockpiles are empty. During this time, the stope mucking operator can continue to muck the stope to a temporary stockpile or move to an alternate level.

Stope mucking rates are reduced based on haulage distance to the access stockpile and are summarized in Table 16-18.

Table 16-18: Production loader productivity

Loader Tram Distance	t/day	Stope Count	Stope Count (%)
0 m to 300 m	1,292	863	44
300 m to 400 m	1,063	384	20
400 m to 500 m	903	287	15
500 m to 600 m	785	178	9
600 m to 700 m	694	127	7
700 m to 800 m	622	67	3
800 m to 900 m	564	37	2

Haul truck requirements were determined based on the truck capacity, average haulage distance to the surface dump location, and loading/dumping cycle times. Annual haulage requirements are illustrated in Figure 16-15.

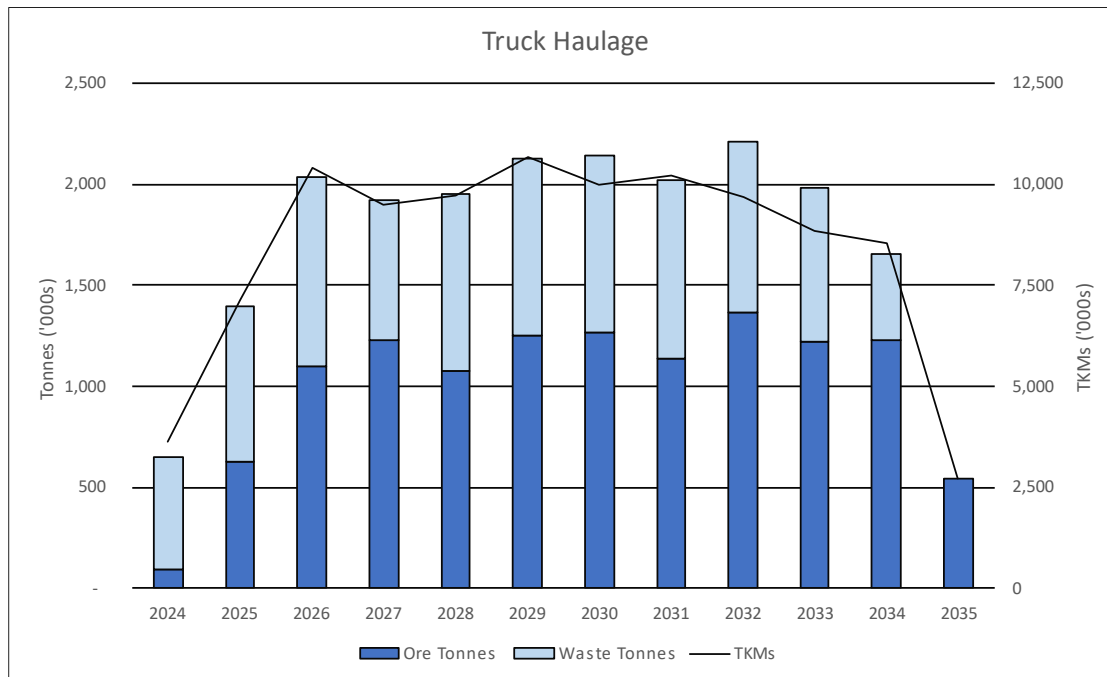

Figure 16-15: Truck haulage requirements



The level of activity per year throughout the various mining zones is illustrated in Figure 16-16.

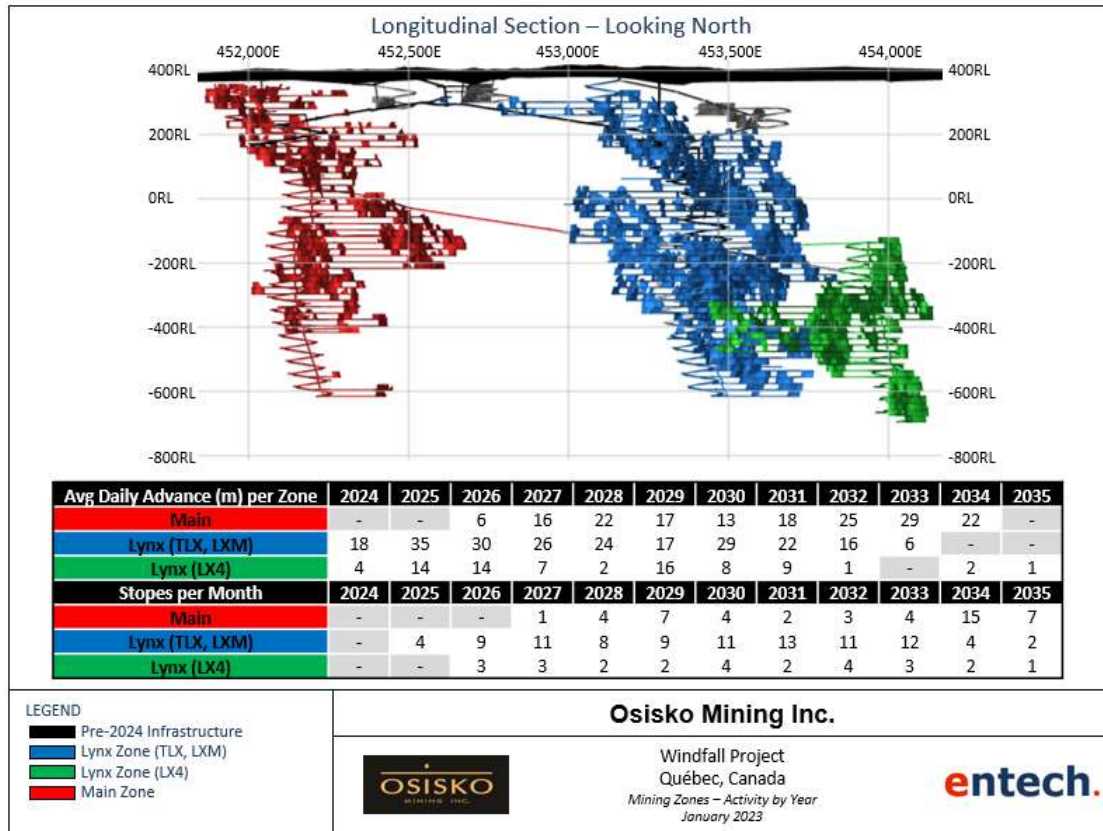

Figure 16-16: Average major activity quantities by year and mining area

16.8.4 Backfill

The selected mining method requires the use of backfill to minimize dilution and to maximize recovery. The construction of the paste backfill facility will not be complete until Q3 2025. During this initial period, cemented rockfill (“CRF”) will be used.

A mobile cemented rockfill mixing truck, with a 12-t capacity of dry material, will bring the cement from surface to the backfill site, where it will use an onboard grout mixer to create cement slurry batches for dispensing into the backfill LHD. A 5% cement content in the backfill was used for cost estimates. The use of the Swatcrete Mobile CRF mixing truck eliminates the need for a complete cement mix/slurry distribution network and an underground storage silo.



Proposed to begin once construction is complete, paste will be pumped underground from surface through a borehole and routed to the stope level through 8-inch schedule 80 and HDPE piping. Downhole stopes will be paste-filled from their overcut level while uphole stopes will be filled through a pastehole drilled from the undercut level.

Pressure monitoring of the paste line will be conducted through pressure transducers located at the bottom of the surface borehole and on each level. The construction of friction loops and implementation of rupture discs are proposed for over pressure protection.

As determined by WSP Canada Inc., paste backfill will be delivered underground at a nominal rate of approximately 3,750 m³ per day. Density is estimated to be 1.8 t/m³, with an average cement content of 3.1% to achieve a strength requirement of 175 kPa in 14 days.

The schedule backfill rate has been reduced from the nominal plant rate of 3,750 m³ per day to account for underground delays, such as water flushes and paste line switchovers for filling of subsequent stopes.

Paste backfill activities and their durations can be found in Table 16-19.

Table 16-19: Paste backfill activity durations

Task	Rate	Duration
Drill Paste + Breather Holes (as required)		0.5 d
Stope Cleanup + Paste Berm/Wall		4 d
First Paste Pour (Plug)	2,500 m ³ /d	-
Initial Cure	-	1d
Second Paste Pour	2,500 m ³ /d	-
Final Cure	-	14 d
Pastefill development (as required)	-	0.5 d

16.8.5 Mine Production Schedule Summary

It is estimated that a total of 2.5 Mt of mineralized material will be recovered through development and 9.7 Mt through stoping, for a total of 12.2 Mt at 8.04 g/t.

Table 16-20 summarizes the Windfall production plan, which is exclusive of the existing surface stockpile.



Table 16-20: Windfall production plan

Mine Production (mineralized material)	Unit	Production												
		2024	2025	2026	2027	2028	2029	2030	2031	2032	2033	2034	2035	Total
Development	kt	93	343	230	328	245	238	248	223	234	198	81	0	2,461
Gold Grade	Au g/t	9.33	8.61	7.56	8.74	6.81	7.76	7.27	9.17	5.94	5.77	6.33	0.00	7.65
Mined Metal	Au oz	28	95	56	92	54	59	58	66	45	37	17	0	606
Stoping	kt	0	287	870	902	830	1,015	1,019	911	1,136	1,024	1,150	545	9,690
Gold Grade	Au g/t	0.00	7.92	8.61	9.99	9.18	8.04	7.22	6.94	9.07	8.16	7.22	6.79	8.14
Mined Metal	Au oz	0	73	241	290	245	263	237	203	331	269	267	119	2,537
Total	kt	93	630	1,100	1,230	1,076	1,253	1,267	1,135	1,369	1,222	1,232	545	12,151
Gold Grade	Au g/t	9.33	8.30	8.39	9.65	8.64	7.99	7.23	7.37	8.53	7.78	7.16	6.79	8.04
Mined Metal	Au oz	28	168	297	382	299	322	295	269	376	305	284	119	3,143
High Grade (Dil. Grade > 3.5)	kt	72	521	1,008	1,088	939	1,100	1,138	980	1,241	1,100	1,155	516	10,857
	Au g/t	11.30	9.49	8.92	10.54	9.49	8.70	7.73	8.07	9.12	8.32	7.44	7.00	8.66
	Au oz	26	159	289	369	287	308	283	254	364	294	276	116	3,025
Low/Medium Grade (1.7 < Dil. Grade < 3.5)	kt	21	109	92	142	136	153	129	155	129	122	77	29	1,294
	Au g/t	2.54	2.62	2.68	2.86	2.81	2.86	2.84	2.96	2.85	2.83	3.01	3.05	2.84
	Au oz	2	9	8	13	12	14	12	15	12	11	7	3	118



Table 16-21 shows the breakdown of Measured and Indicated material included in the mine production schedule. Waste dilution includes planned and unplanned dilution as described in Section 16.5.2. Inferred material tonnes are considered waste dilution in the Study and are tabulated separately for illustrative purposes.

Table 16-21: Resource category breakdown

Zone	Category	Tonnes (Mt)	Grade (gpt)	Metal (koz)
Lynx	Measured	0.4	12.37	155
	Indicated	4.2	14.20	1,896
	Mineralized Material Subtotal	4.5	14.05	2,051
	Inferred	1.1	-	-
	Waste Dilution	1.6	-	-
	Dilution Subtotal	2.6	-	-
	Ore Total	7.2	8.89	2,051
Main	Measured	0.1	9.56	19
	Indicated	1.6	9.26	467
	Mineralized Material Subtotal	1.6	9.27	485
	Inferred	0.1	-	-
	Waste Dilution	0.8	-	-
	Dilution Subtotal	0.9	-	-
	Ore Total	2.5	6.00	485
Development	Measured	0.1	11.49	41
	Indicated	1.5	11.70	565
	Mineralized Material Subtotal	1.6	11.69	606
	Inferred	0.2	-	-
	Waste Dilution	0.7	-	-
	Dilution Subtotal	0.8	-	-
	Ore Total	2.5	7.65	606
Total	Measured	0.6	11.90	215
	Indicated	7.2	12.61	2,928
	Mineralized Material Subtotal	7.8	12.56	3,142
	Inferred	1.3	-	-
	Waste Dilution	3.0	-	-
	Dilution Subtotal	4.4	-	-
	Ore Total	12.2	8.04	3,142



16.9 Underground Mine Services

16.9.1 Electrical Services

16.9.1.1 Electrical Distribution

A distribution network of 13.8 V will be deployed from the existing surface network to meet the energy needs at the Windfall Project. The underground is already supplied with 13.8 kV in the exploration ramp, with a redundant link in the Lynx vent raise.

One out of three levels will be powered by a 1,500 kVa substation. This substation will supply power to the level above and level below.

The 13.8 kV stations will be divided into groups, allowing isolation within those groups. When electrical work is required, partial outages would replace mine-wide outages, allowing mine operations to resume in most of the mine.

Once the Main and Lynx zones are joined through the bypass, a redundant system will be installed for improved reliability.

16.9.1.2 13.8 kV Installation

To supply power to the mining equipment, portable 13.8 kV/600 V substations will be installed in electrical substations with a junction box to provide point connection to the main Network.

Medium voltage circuit breaker and isolation switch, 600 V distribution panel, transformer, and service panel of 120 V/208 V, starters, variable speed drives, communications cabinet and PTOs will be installed on the side wall. Each station will be designed according to the needs for that level and the levels above/beneath it.

On levels with development exceeding 525 m from the 13.8 kV substation at the level access, another substation will be installed on the level. This substation would be able to feed the upper and lower levels, as necessary. Required development and service holes for this configuration have been included in the mine design.

16.9.1.3 600 V Installations

Where there is less need for energy, 13.8 kV portable substations will not be used. A 600 V distribution from the upper level will be deployed at a maximum distance of 300 m as per site standards.



16.9.1.4 Voice Communication System

The fibre optic network will be installed through every electrical substation, providing mine-wide network coverage. A Long-Term Evolution (“LTE”) network will be installed alongside the fibre network to provide vocal communication between employees and wireless communication for the equipment.

A FEMCO communication system will be available in every refuge with a direct link to surface, as well as a telephone system for emergencies.

16.9.1.5 Fibre Optics

A 48-fibre cable will be installed alongside the 13.8 kV power cable, from surface into the mine, for each ramp system (Lynx & Main). Full coverage is proposed throughout the mine with redundancy as described with the 13.8 kV distribution.

The fibre optic network will be spread between each of the levels from surface. This network will be the main network for the Windfall Project.

16.9.1.6 LTE Network

An LTE network will be deployed on all levels, providing greater flexibility and practicality than optical fibre. The effectiveness of personnel and vehicle tracking will be improved with this network.

16.9.1.7 Automation Network

An automation network will be deployed to obtain real-time information and control on pumping, ventilation, and other installations.

16.9.1.8 Teleoperation

LTE hotspots will be installed and positioned to allow complete coverage of the production levels. It will be connected to the fibre optic network in each substation.

16.9.1.9 Ventilation-on-demand

The optical fibre and LTE network will be used for gathering critical information for the control of the ventilation-on-demand system.

Vehicle and cap lamp tags will allow the software to locate personnel and vehicles anywhere in the mine. Air supply can then be adjusted according to their positions.



16.9.1.10 Collision Warning System

Tags installed in the lamps and on the vehicles can also serve as a collision warning system with the installation of a module in the vehicle.

16.9.2 Fuel Distribution Network

Windfall will have a fuel bay located adjacent to the garage at -140 RL in the Lynx zone. Fuel will be provided from a 550 m borehole lined with steel pipe from the site's surface fuel farm. The general fueling strategy will be for LHDs to be fueled underground, while haulage trucks and light vehicles to be fueled on surface, with the fuel bay used as required during the shift. The expected maximum consumption for all diesel mobile equipment is 7 million litres of diesel per year. The remainder of the mine's equipment is proposed to be battery-electric and will require recharging through the mine's underground electrical distribution network.

16.9.3 Permanent Mine Pumping Network

A water management system has been designed to handle 5,200 m³/day of water. This volume includes water from infiltration and mining activities. The planned system will pump dirty water to surface for treatment before being recirculated underground for use in operations. Pumping requirements are tied directly to development and production activities, providing complete dewatering capabilities throughout the mine life.

The proposed pumping strategy for Windfall is comprised of the following:

- A primary pumping station, located in the Lynx zone on level 0460, is planned to be commissioned ahead of the Project start. The feasibility design for the Lynx zone will have all water report to this pumping station before being pumped to surface;
- All new primary pumping systems will be comprised of helical rotor style pumps (110 kW, WT 107 or equivalent) that are designed to pump both clean and dirty (up to 5% solids) water. The pumps are capable of up to 20 l/s over 330 m of head (or a reduced rate up to 420 m of head). At each pump station, it is proposed that a minimum one duty and one standby pump be installed;
- Secondary pumping system, where semi-permanent (travelling) helical rotor style pumps (75 kW, WT 0X3 or equivalent) will transfer mine water to the permanent pump stations. The pumps can displace up to 20 l/s over 130 m of head (or a reduced rate up to 180 m of head) and will be positioned below permanent pump installations. These pumps will be daisy-chained as mining progresses deeper until the next permanent pump station is installed where the entire 75 kW daisy-chain system is then re-purposed;



- Tertiary systems include 8-20 kW sump pumps where mine water will be captured in sumps or the ramps, and will transfer mine water to the travelling helical rotor pumps; and,
- Connected drain holes between sumps will keep water from migrating onto ramps and direct water to either the semi-permanent or permanent pumps via piping.

The overall system is designed to minimize the use of settling sumps and keep solids in solution to be managed on surface. This strategy is to minimize damage to loaders that can result from water ingress during mucking of the settling sumps.

The location of all planned pumping stations is illustrated in Figure 16-17.

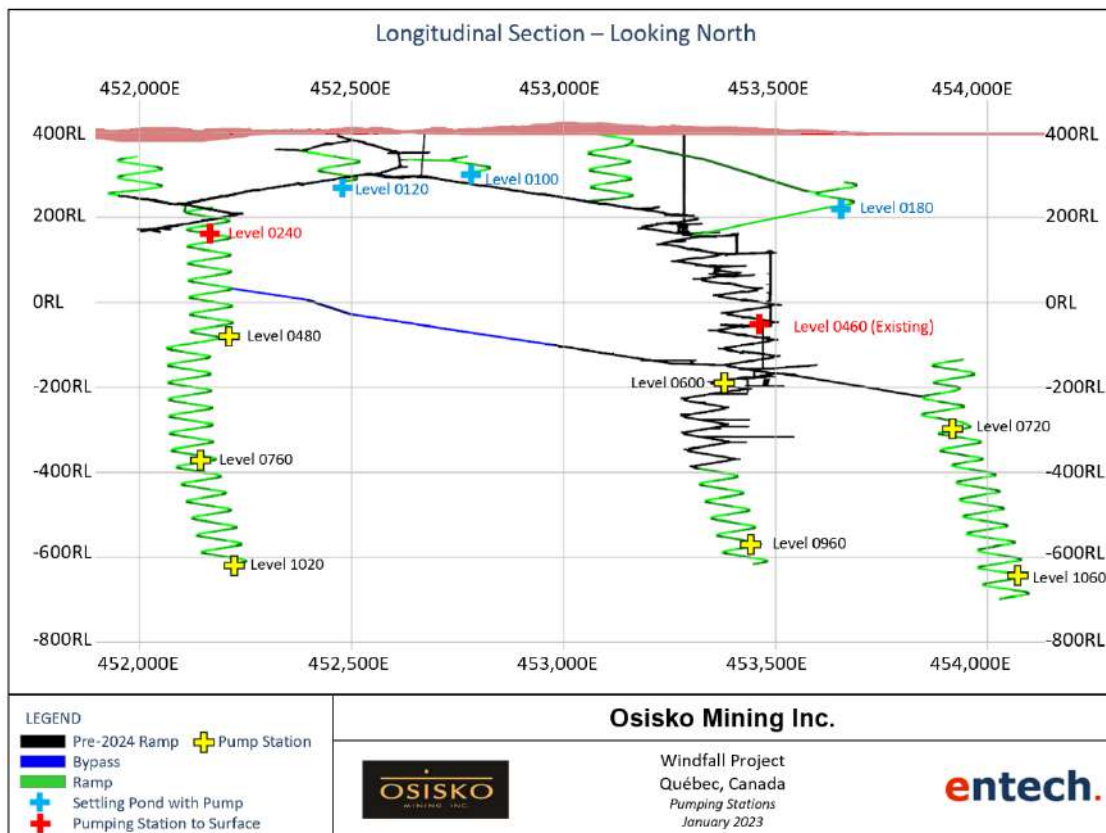

Figure 16-17: Pumping stations

Permanent pumpstations will be constructed at selected intervals and at the bottom of each down ramp. Mine water will then be pumped upwards through 8-inch pipes located in the ventilation/egress raise.



Three additional pumps, each located at the bottom level of the FZN satellite zones, will direct water to permanent pumpstations on levels 0240 in the Main zone (for zones F11 and F17) and 0460 in the Lynx zone (for zone F51). Two permanent pumpstations, located at RL 0240 in the Main zone ramp and 0460 in the Lynx zone ramp, will pump to the water treatment plant on surface.

Each permanent pumpstation will have operating and standby pumps as detailed in Table 16-22. Challenge pumps were selected based on their modularity, robustness, and limited maintenance requirements.

Table 16-22: Pumpstation operating details

Description	Ramp System	Level	Pump Type	Pump kW Rating	Quantity
Pumpstation 1020	Main	1020	Challenge Pumps WT107	110	2 Operating 2 Standby
Pumpstation 0760	Main	0760	Challenge Pumps WT107	110	2 Operating 1 Standby
Pumpstation 0480	Main	0480	Challenge Pumps WT107	110	1 Operating 1 Standby
Pumpstation 0240 – to Surface	Main	0240	Challenge Pumps WT107	110	1 Operating 1 Standby
Pumpstation 1060	Lynx East	1060	Challenge Pumps WT107	110	1 Operating 1 Standby
Pumpstation 0720	Lynx East	0720	Challenge Pumps WT0X3	110	1 Operating 1 Standby
Pumpstation 0960	Lynx Central	0960	Challenge Pumps WT107	110	2 Operating 2 Standby
Pumpstation 0600	Lynx Central	0600	Challenge Pumps WT0X3	110	2 Operating 1 Standby
Pumpstation 0460 – to Surface	Lynx Central	0460	Nietzch NM125SY10S60Z	224	2 Operating 4 Standby



16.9.4 Compressed Air Network

A compressed air network has been designed to achieve an underground peak airflow requirement of 2920 CFM (~600 hp) using 3-surface-based compressors and a 3,000-gallon air receiver. A 6-inch diameter piping network will provide the underground's compressed air needs through the mine's down ramp system, switching to a 4-inch line on level accesses.

16.9.5 Ventilation Network

16.9.5.1 Primary Ventilation

The Windfall Project currently has two ventilation raises to surface, which will be used as exhaust raises for the Bobcat and Lynx zones, with three planned raises to surface providing exhaust for the Main zone and two F-zone satellite mining areas. These exhaust raises will be equipped with fans and will create a pull system with fresh air being drawn down the two portal ramps.

The proposed ventilation circuit was imported into Ventsim®, an industry-standard software used in ventilation modelling, to model the flows predicted for the mine. The ventilation demand was estimated based on Québec Regulation Respecting Occupational Health and Safety in Mines ("RROHS"), which requires adherence to CAN/CSA-M424.2-M90 Non-railbound Diesel-powered Machines for use in Non-gassy Underground Mines for approved diesel engines or a minimum ventilating airflow of 145 CFM per hp (0.09 m³/s per kW) of mobile equipment where the engine has not been approved by MMSL-CANMET.

The estimated ventilation demand is shown in Table 16-23.



Table 16-23: Ventilation demand estimate

Diesel Equipment	Model		Engine	Power Output	Unit Demand	Utilization (%)	Main Zone			Lynx Zone		
				(kW)	(m3/s)		Units	kCFM	m ³ /s	Units	kCFM	m ³ /s
LHD	Epiroc	ST14	Cummins X12 Tier 4F / EU Stage V	250	9.3	100%	3	59.1	27.9	4	78.8	37.2
LHD	Epiroc	ST18	Cummins X15 Tier 4F / EU Stage V	399	9.3	100%	1	19.8	9.3	2	39.6	18.7
Truck	Epiroc	MT54	Cummins QSK19 EPA Tier 4	567	12.7	100%	6	161.5	76.2	9	242.2	114.3
2yd with forks	Epiroc	ST2	Cummins QSB4.5 Tier 3 / EU Stage IIIA	170	8.1	50%	1	8.5	4.0	1	8.5	4.0
Shotcrete Sprayer	SWATCRETE	SWATCRETE	Mercedes 906	150	8.6	10%	1	1.8	0.9	1	1.8	0.9
Cement Mobile Unit	SWATCRETE	SWATCRETE	Mercedes 906	150	8.6	10%	1	1.9	0.9	1	1.9	0.9
Mine Transport / Service	Kovatterra	K200 & MT100	Cummins / QSB 3.3, Turbocharged Diesel, Tier III	74	2.8	33%	7	14.0	6.6	21	42.0	19.8
Equipment Airflow Requirement								266	126		414	196
Leakage / Contingency (30%)								80	38		124	59
Total Airflow Requirement								346	164		539	255
Total Mine Airflow Required											886	418



Two primary fans are proposed to be installed at the surface extents of the Main and Lynx exhaust raises to pull exhaust air out of the mine, with 165 m³/s and 255 m³/s exhausted from the Main and Lynx, respectively, for a total of 420 m³/s to maintain adequate airflow throughout the mine. Rigid ducting into the portal entrances will be used to provide heated air throughout the ramp during the winter months. The proposed fan installations are illustrated in Figure 16-18 and summarized in Table 16-24 and Table 16-25.

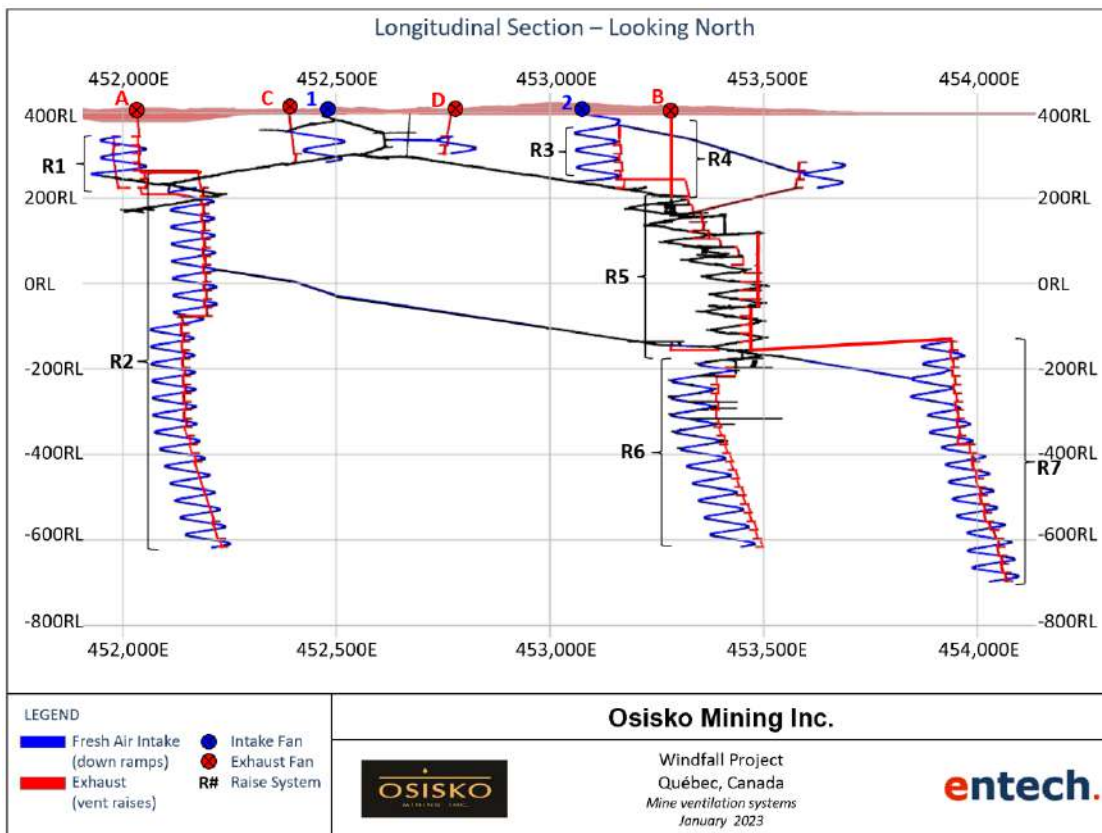

Figure 16-18: Primary mine ventilation system



Table 16-24: Primary ventilation fan summary

Label	Name	Total Nominal Power	Fan Size	Total Q value (m ³ /s)	Total P value (kPa)	Description
Exhaust Fans						
A	Main Zone Exhaust Fan	816 kW	550 HP	211	2.6	2 fans in parallel
B	Lynx Zone Exhaust Fan	1266 kW	850 HP	274	3.5	2 fans in parallel
C	FZ11 Exhaust fan	280 kW	375 HP	133	0.9	Single fan
D	FZ17 Exhaust Fan	280 kW	375 HP	133	0.9	Single fan
Intake Fans						
1	Main Portal Intake Fan	63 kW	84 HP	80	0.5	Single fan
2	Lynx Portal Intake Fan	126 kW	84 HP	144	0.5	2 fans in parallel

Table 16-25: Ventilation raise summary

Label	Elevation	Diameter (m)	K value (kg/m ³)	Status
R1	Surface to 280RL	6	0.071	Planned
R2	280RL to Bottom	5	0.005	Planned
R3	360RL to 220RL	5	0.005	Planned
R4	Surface to 155RL	6	0.071	Existing
R5	280RL to -200RL	5	0.005	Planned
R6	-200RL to Bottom	5	0.005	Planned
R7	-200RL to Bottom	5	0.005	Planned

16.9.5.2 Auxiliary Ventilation

Where headings are outside of the primary ventilation circuit, auxiliary fans are required to push the air to the working headings. Auxiliary ventilation fans rated 85-150 hp will be in flow-through airflow on each level access with flexible ducting delivering approximately 6-10 m³/s to each working heading. Where appropriate, different fan sizes and airflow requirements may be required.



16.9.5.3 Secondary Means of Egress and Refuge Chambers

The Windfall Project mine design includes the installation of refuge stations in compliance with the Québec Regulation Respecting Occupational Health and Safety in Mines. The mine also has an emergency escapeway raise system to surface equipped with ladders and is planned to be accessible from every level through ventilation raises.

16.10 Underground Mine Equipment

To optimize material movement, 14 and 18 t capacity LHDs have been selected for mucking and truck loading activities. 14 t capacity LHDs are proposed for smaller profile development headings and stope mucking. 18 t capacity LHDs are proposed for large profile development headings and to load the 54 t trucks at the level accesses.

The working schedule for the production and development crews is two shifts per day, at 12 hours per shift, 365 days per year. A utilization of 85% was assumed for all major equipment.

Productive working time was calculated using assumed delays, as can be seen in Table 16-26.

Table 16-26: Productive working time calculation

Item	Unit	Rate
Shifts Per Day	#	2
Shift Length	hour	12
Inactive Time Per Shift	min	185
Available Time Per Shift	min	720
Productive Time Per Shift	min	535
Productive Time Per Day	min	1,070

16.10.1 Mine Equipment List

All mining and maintenance activities, with the exception of vertical development and concrete delivery, will be completed by a company workforce using company-owned equipment. A total of 90 units of mobile equipment will be required for the Project as listed in Table 16-27. Apart from LHDs, trucks, mancarriers and concrete delivery equipment, all remaining equipment will be battery electric. Battery electric equipment will charge via PTO while stationary (either working or idle).



Table 16-27: Mining equipment

Mining Equipment	Make and Model	2024	2024-2035
		Initial Fleet	Max units
Production / Development Equipment			
Jumbo (2 boom)	Epiroc M20-EV	3	5
Bolter	MacLean 975 - EV Omnia	5	7
Cable Bolter	MacLean 975 - EV Omnia High Reach	1	1
Emulsion Charger (Dev)	MacLean EC3-EV	2	3
Emulsion Charger (Prod)	MacLean CS3-EV	0	2
Stope Loader - 14 t	Epiroc ST14	2	5
Truck Loader - 18 t	Epiroc ST18	2	3
Truck 54 t	Epiroc MT54	6	10
Production Drill	Epiroc Simba ME7C-EV	0	5
ITH/V30 Drill	Sandvik DL 432i	1	2
Scissor Lift	MacLean SL3-EV	2	5
Total Prod/Dev Units		24	48
Service Equipment			
Block Holer	MacLean BH3-EV	1	1
Boom Truck	MacLean BT3-EV	1	2
Material Movement 2yd	Epiroc ST2	1	2
Grader	MacLean GR5-EV	1	2
SWATcrete Mobile CRF Unit	Contractor Unit	1	1
SWATcrete Sprayer	Contractor Unit	1	1
Personnel Carrier	MacLean PC3-EV	1	2
Supervision and Personnel Carrier	Kovaterra - K200 - IFIX10017	6	12
Personnel Carrier with Forks	Kovaterra - MT100 - IFIF99290	3	5
Service Truck - Tech Services	Kovaterra - K200 - IFIX10049	1	5
Service Truck with Surveyor Lift	Kovaterra - K200 - IFIX10029	2	2
Service Truck with Crane	Kovaterra - K200 - IFIX10022	1	1
Service Truck - Mechanic	Kovaterra - K200 - IFI10528	3	3
Service Truck - Construction	Kovaterra - MT100 - IFIF99338	2	3
Total Service Units		25	42
Total Units		49	90



16.11 Mine Personnel

The Windfall Project will operate seven days per week, with 12-hour shifts day and night, 365 days per year. Table 16-28 lists the personnel requirements for the underground operation. Note that not all positions work night shifts.

Table 16-28: Underground personnel requirements

Personnel	2024-2035	2024-2035
	Max Company Headcount	Max Contractor Headcount
Mine Operations		
Jumbo Operator	20	
Bolter Operator	24	
Development Blaster	16	
Development Services Miner	20	
Stope Prep Miner	6	
Production Drill Operator	18	8
Production Blaster	12	
LHD Operator	36	
Truck Operator	32	
Cable Drill Operator	4	
Construction Miner	8	8
Grader Operator	6	
Diamond Driller		44
Underground Staff and Supervision		
Mine Operations Manager	1	
Mine Superintendent	2	
Mine Captain	2	
Mine Supervisor	16	
Dispatch	4	
Technical Services		
Technical Services Manager	1	
Chief Engineer / Geologist	2	
Senior Engineer / Geologist	4	
Engineer / Geologist	18	
Engineering / Geological Technician	45	



Personnel	2024-2035	2024-2035
	Max Company Headcount	Max Contractor Headcount
Maintenance		
UG Maintenance Superintendent	1	
Maintenance Supervisor	4	
Mobile Mechanic	32	
Fixed Maintenance Mechanic	6	
Mechanical/Electrical Planner	4	
Automation/Communication Specialist	8	
UG Electrical Supervisor	2	
Electrician	16	
Electrical Engineer	2	
Total	372	60



17. Recovery Methods

The flowsheet for the Windfall Project was established on the basis of laboratory-scale testwork, mainly performed at the SGS Québec and SGS Lakefield laboratories. The testwork results are described in Chapter 13. The resulting flowsheet reflects the results of this initial testwork and forms the basis for the plant design.

The process plant consists of primary crushing, followed by a grinding circuit consisting of a semi-autogenous mill ("SAG") in closed circuit with a pebble crusher and ball mill (in closed circuit with cyclones – ("SABC") circuit). A gravity circuit, followed by intensive leaching, recovers free gold from the grinded cyclone underflow, while the cyclone overflow is treated in a leaching and carbon-in-pulp ("CIP") circuit. Gold and silver are recovered in an adsorption-desorption-recovery ("ADR") circuit. Electrowinning ("EW") cells and a gold room recover the gold and produce doré. The plant also includes a reagent preparation area and process and industrial water circuits to service the entire plant. A cyanide destruction circuit is also included to treat CIP tails before being sent to the tailings filtration plant.

The process plant is followed by a tailings filtration plant with filter press to produce paste backfill to send underground and filtered tailings for storage in the tailings management facility

A schematic process flow diagram of the process plant is presented in Figure 17-1.

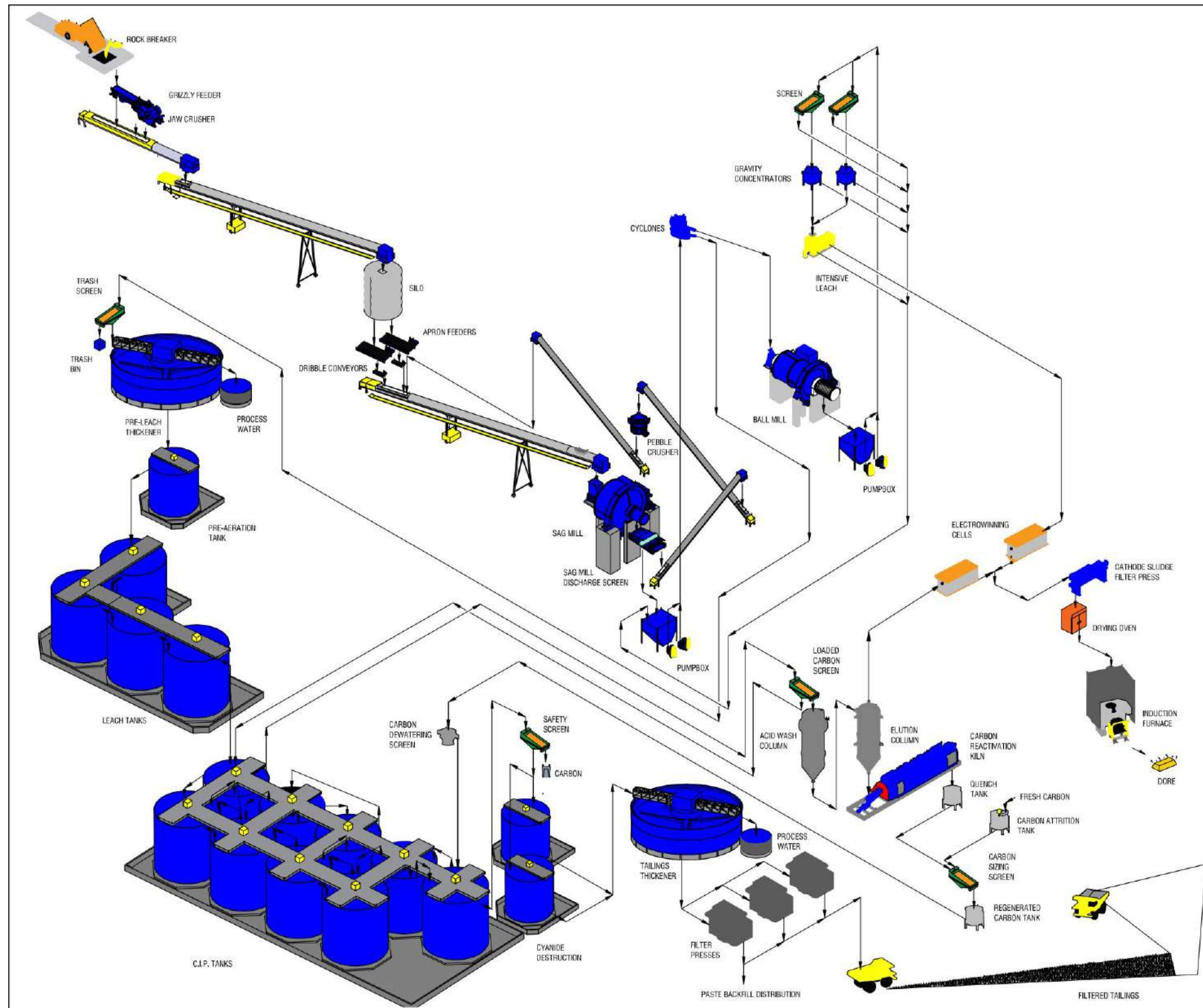

Figure 17-1: Simplified process flow diagram



17.1 Process Plant Design Criteria

The design criteria to determine the sizing of the equipment are based on a nominal process plant throughput capability of 3,400 tpd. With a 92% plant availability and design factor used, the maximal daily throughput is 4,080 tpd.

Table 17-1 presents an overview of the main design criteria parameters used. The values presented were derived from testwork data, benchmarked values, BBA's database or based on Osisko's requirements.

Table 17-1: Summary of key process design criteria

Description	Unit	Value
Plant throughput	tpd	3,400
Average Au feed grade	g/t	8.06
Average Ag feed grade	g/t	4.18
Crushing plant utilization	%	65
Process plant utilization	%	92
Au recovery by gravity circuit	%	31.2
Ag recovery by gravity circuit	%	22.4
Grind size to leaching, P ₈₀	µm	37
Leaching retention time	hr	36
Au recovery by CIP	%	90.0
Ag recovery by CIP	%	79.1
Carbon stripping, regeneration capacity	tpd	7
Overall recovery	-	-
<ul style="list-style-type: none"> ▪ Au Recovery ▪ Ag recovery 	%	93.1
Residual total cyanide concentration at plant discharge, (average/max)	mg/L	avg 10-max 20
Final tailings slurry density target	% w/w	48



17.2 Process Plant Facilities Description

17.2.1 Crushing, Storage and Reclaim

Ore transported from the underground mine will have a F_{80} of 400 mm. Each rear dump truck from Windfall Mine ramps will carry a total of 50 tonnes per load. A run-of mine (“ROM”) stockpile close to the crushing plant will be primarily utilized for emergency storage. A static grizzly (400 mm), mounted above the ROM bin, and a rock breaker will be installed. Material is withdrawn from below to the vibrating grizzly where the oversize material is directed to an open circuit jaw crusher to further reduce the material to a P_{80} of 114 mm. A baghouse dust collection system will capture the dust created by the crushing operations. The jaw crusher product and vibrating grizzly undersized are collected on a conveyor belt that feeds the crushed ore silo. The live silo capacity is 4,010 t, or 26 hours of nominal capacity. A layout is presented in Figure 17-2.

Two discharge points from the silo feed two feeders, respectively. The feeders discharge to the semi-autogenous grinding (“SAG”) mill feed conveyor that will convey the crushed rock to the SAG mill feed chute. Fine material from the feeders is captured on two dribble conveyors that also discharge onto the SAG mill feed conveyor. The SAG mill feed conveyor will be fitted with a weightometer.



Figure 17-2: Process plant feeding circuit



17.2.2 Grinding Circuit and Gravity Recovery

The grinding circuit will be a SABC circuit, comprised of a single variable speed SAG and a single variable speed ball mill. The SAG mill will operate in closed-circuit with a pebble crusher, followed by a ball mill, operated in closed-circuit with cyclones. The product particle size exiting the grinding circuit cyclone overflow will contain 80% passing 37 μm material. The SAG and ball mill area is serviced by overhead crane.

SAG Mill Circuit

The reclaimed crushed rock is conveyed to the SAG mill feed chute via the SAG mill feed conveyor. A SAG mill size of $\text{Ø}7.32 \text{ m} \times 2.82 \text{ m}$ ($\text{Ø}24' \times 9.25'$) effective grinding length (“EGL”) was selected with a total installed power of 2,800 kW to grind the rock to a P_{80} of 1 mm. The SAG mill will be fitted with discharge grates.

The mill is operated with a charge of $\text{Ø}127 \text{ mm}$ steel balls.

The SAG mill product discharges to a single deck vibrating screen. The oversize is conveyed to the pebble crusher and the undersize discharges into a pump box which then feeds the ball mill via a cyclone cluster. The crushed pebbles are recirculated to the SAG mill feed conveyor. A dust collector removes fines created from the discharge of the pebble crusher. A layout of the SAG mill circuit is shown in Figure 17-3.

Oversize from the SAG mill discharge screen will be conveyed to the pebble crusher via two belt conveyors. A self-cleaning tramp metal magnet will be mounted above both pebble recycle conveyors. Downstream of the first tramp metal magnet, pebbles will pass under a metal detector, prior to discharging onto a swing belt feeder.

Undersize from the SAG mill discharge screen will be pumped to the cyclone cluster via a pump box. The cyclone cluster is fed via a variable-speed centrifugal pump connected on the cyclone feed pump box.



Figure 17-3: SAG mill circuit

Ball Mill Circuit

A ball mill, $\text{Ø}5.18 \text{ m} \times 9.5 \text{ m}$ ($\text{Ø}17' \times 31'$) EGL, fitted with a trommel screen, was selected for secondary grinding. The total installed power is 4,200 kW. The ball mill will be operated in closed-circuit with a cluster of hydrocyclones producing an average cyclone overflow product P_{80} of $37 \mu\text{m}$. This product will feed the pre-leach thickener.

The ball mill will be charged with $\text{Ø}50.8 \text{ mm}$ steel balls. The ball mill is fitted with a trommel screen and discharges into a pump box which then feeds the gravity concentrators via the gravity concentrator screens.

The cyclone overflow is sent to the vibrating trash screen ahead of the pre-leach thickener and the CIP circuit, while the oversize material in the underflow is returned to the ball mill.



Gravity Circuit

The gravity circuit feed pump box at the ball mill trommel undersize will feed two gravity scalping screens via a split box. The coarse material from the scalping screen will be sent to the cyclone feed pump box. The undersized material from the screens will feed two gravity concentrators, arranged in parallel. The gold concentrate from both gravity concentrators will feed an intensive leaching reactor (“ILR”) operating in batch mode. The gravity concentrator tails will return to the cyclone feed pump box.

The pregnant gravity solution from the ILR will be pumped to a dedicated EW cell via a pregnant solution tank located in the gold room. A sampler will be installed on the pregnant gravity solution line. The ILR tailings will be returned to the cyclone feed pump box via a pump. A layout of the gravity circuit is shown in Figure 17-4.



Figure 17-4: Gravity circuit



17.2.3 Carbon-in-Pulp

Pre-leach Thickening

Prior to leaching, the ground slurry received from the cyclone overflow will pass through a trash screen before feeding the pre-leach thickener feed box. The pre-leach thickener diameter is Ø24 m. Underflow from the pre-leach thickener at 50% (w/w) will be pumped to the leaching circuit. The thickener overflow water is sent to the process water tank.

Leaching

The pre-leach thickener underflow slurry will be pumped to the leaching circuit, consisting of one pre-aeration tank and four leaching tanks. Each tank will be 14 m in diameter, mechanically agitated, and operating in series. Slurry will first flow into the pre-aeration tank to be aerated with sparged oxygen. Lime is added to the tanks to maintain a pH of approximately 11. Lead nitrate and sodium cyanide will also be added to leach gold along with oxygen sparged. The leached slurry will flow from the final leaching tank to the CIP feed launder.

CIP

The CIP circuit consists of nine CIP tanks operating in carousel mode. In this mode of operation, the activated carbon is kept within the CIP tanks, while the slurry is pumped between tanks through CIP pumping interstage screens. The slurry inlet and outlet are moved to achieve a countercurrent flow of pulp to the carbon in the tank by alternating the feed and discharge CIP tank. A layout presenting the CIP circuit, along with the ADR circuits is shown in Figure 17-5.



Figure 17-5: CIP circuit

17.2.4 Adsorption, Desorption and Recovery Circuit

The gold recovery circuits are based on the processing of 7 tpd of loaded carbon with a high pressure Zadra process

Carbon Elution

Loaded carbon from the CIP circuits is transferred to a loaded carbon screen via loaded carbon pumps. The undersize from this screen is recycled to the CIP feed launder. The oversize is sent intermittently to the 47-t capacity acid wash vessel. Carbon transport water drains from the acid wash vessel and is sent to the fine carbon collection tank.

A batch of 3% (w/w) hydrochloric acid cold solution is prepared in the dilute acid wash tank by transferring concentrated acid 28% and industrial water. The acid wash sequence will involve the injection of the dilute acid solution into the column, by the dilute acid circulation pump, via the feed manifold located beneath the column. Once the required amount of acid has been added to the column, the dilute acid circulation pump will be stopped, and the carbon will be allowed to soak. Upon completion of the acid soak, the acid rinse cycle will be initiated by pumping water



through the column, to displace the spent acid solution to the tailings thickener. Acid rinse water will be sourced from the fine carbon collection tank and pumped through the column by the transfer water pump. During the rinse cycle, water will be pumped through the column. Part of the water will include a caustic injection, to neutralize the acid waste, whilst the rest is a fresh water rinse. Acid waste and displaced solution from both the acid rinse and wash steps will pass through the acid wash discharge strainer before discharging to the tailings thickener feed box.

The sequence will conclude with carbon being transferred to the elution column. Water, for carbon transfer between the acid wash and elution columns, will be supplied from the fine carbon collection tank via the transfer water pump.

Carbon elution, or stripping, is initiated when a barren strip solution of 1% NaOH and 0.5% NaCN circulates through the elution column at a flow rate of two bed volumes per hour for 10.5 hours at an elevated temperature and pressure. The solution exits the elution column as pregnant solution (e.g. loaded strip solution). The recirculated strip solution flows from the barren tank through a heat exchanger before entering the stripping vessel. Final heating of barren solution is achieved using another heat exchanger, where the strip solution is contacted with hot water heaters, to reach the nominal strip solution temperature. A pressure control valve on the pregnant solution line maintains the column at a nominal pressure of 650 kPa to ensure that the strip solution does not boil. All, or part, of the elution solution can be discarded on a routine basis to prevent build-up of contaminants.

After a carbon strip is complete, transport water flows to the elution column and a pump transfers the carbon to a dewatering screen. The undersize fraction from the carbon dewatering screen reports to the fine carbon collection tank and the oversize reports to the carbon regeneration kiln feed bin.

Carbon Regeneration and Fines Handling

A carbon regeneration kiln reactivates the stripped carbon. The regeneration kiln operates at a nominal temperature of 700-800°C to reactivate the carbon activity close to its original level.

The kiln discharge reports to the carbon quench tank.

New carbon enters through a carbon attrition tank. New carbon and regenerated carbon pass through a sizing screen. Undersize carbon reports to the fine carbon collection tank while the oversize is pumped to the carbon dewatering screens of the CIP circuit.



Settled carbon from the fine carbon collection tank will be transferred to a plate-and-frame filter press for dewatering. The filter press cake is bagged in tote bags and transported off-site once sufficient inventory has built up. The fines will be sold to a third party for recovery of the metal values contained in the carbon. The carbon fines filter press filtrate returns to the fine carbon collection tank.

Electrowinning and Gold Casting

Three EW cells recover gold and silver from the pregnant strip solution. The solution exiting the cells reports to the EW cell discharge pump box and is pumped to the barren stripping solution tank. A separate dedicated EW cell treats the intensive cyanidation pregnant solution. Each EW cell is equipped with a rectifier.

A fourth EW cell will be dedicated to the ILR pregnant solution. Pregnant eluate from the intensive cyanidation reactor will be stored within a dedicated ILR pregnant eluate tank. Once sufficient pregnant eluate is available, within the ILR pregnant eluate tank, the EW sequence will be initiated by starting the ILR EW Feed Pump. The flow of pregnant eluate to the dedicated ILR EW cell will be manually controlled to sustain the desired linear velocity. During the EW cycle, the EW cell discharge will be continuously returned to the ILR pregnant eluate tank, via gravity.

The pregnant strip solution and the ILR pregnant solution are maintained as separate streams. Both streams are smelted separately for accounting purposes.

The EW cells are fitted with stainless steel anodes and stainless steel cathodes. A cleaning system, using high-pressure water, washes the gold-bearing sludge from the cathodes. A filter press removes excess moisture from the separated gold sludge. Following filtration, the precious metal sludge is dried in an oven.

The dry EW sludge is cooled and mixed with fluxes before being fed to the induction smelting furnace. The gold and silver doré is poured from the furnace into a cascade of moulds. The refining area and gold room are secure areas.

17.2.5 Cyanide Destruction Circuit and Tailings Treatment

Cyanide Destruction

Tailings from the CIP circuit will be sent to a carbon safety screen. The safety screen oversize will report to a carbon bag while the undersize will gravitate to the CIP tails pump box. A sampler, installed on the Cyanide Destruction (“CND”) circuit feed, will periodically collect a sample of the adsorption tail stream.



A CND circuit treats the CIP tails at 50% (w/w) solids. Cyanide destruction is completed using the liquid SO₂/Oxygen process.

The CND process occurs in two tanks operating in parallel, providing a total retention time of 2 hours. Liquid SO₂ is added to the tank from a liquid SO₂ storage tank and oxygen gas injected through cone spargers located at the bottom of tank to oxidize the cyanide species present. Copper sulphate will be added to the CIP tails pump box that feeds the CND tanks. Hydrated lime addition controls the pH in the tank. An agitator ensures adequate mixing and gas dispersion.

The treated tails are subsequently pumped to the tailings thickener.

17.2.6 Process Plant Services Requirement

17.2.6.1 Water Requirements

Water requirements for the plant are divided into two main areas, industrial water and process water.

The total industrial water requirement for the process plant (including process water tank makeup) was estimated at approximately 194 m³/d.

The industrial water is transferred from the filtration plant and the water treatment plant to be used in the following areas:

- Gravity circuit;
- Intensive leach reactor;
- Filter wash water;
- Gland seal water;
- Carbon elution (acid wash, strip solution make-up, EW solution cooling);
- Reagent preparation;
- Process water tank makeup;

Process water is used throughout the plant and is a combination of the pre-leach thickener overflow and industrial water makeup.



17.3 Reagent Systems

A summary of the reagents required in the process plant is presented in Table 17-2, along with the expected form of supply and mixing requirements.

Table 17-2: Reagent mixing systems

Reagent	Delivery	Preparation
Quick lime ("CaO")	Trucks – solid	Lime slaking system, water addition
Sodium cyanide ("NaCN")	Tankers – liquid	No preparation required
Hydrochloric acid ("HCl")	Totes – liquid	Mixing tank, water addition
Sodium hydroxide ("NaOH")	Tanker – liquid	No preparation required
Flocculant	Bags – solid	Eductor, mixing tank, water addition to in-line mixer
Sulphur dioxide (SO ₂)	Tanker – liquid	No preparation required
Copper sulphate ("CuSO ₄ .5H ₂ O")	Super sacks – solid	Mixing tank, water addition
Anti-scalant	Tote – liquid	No preparation required
Leach Aid (ILR)	Bucket – solid	No preparation required
Fluxes	Bags – solid	No preparation required

Receiving tanks are provided for liquid sodium cyanide and sodium hydroxide and are sized to hold approximately the capacity of one delivery tanker plus 2 days and 1 week of consumption respectively. For solid reagents, an agitated mixing tank is equipped with batch controllers used to mix to the required reagent concentration. The mixing tank is typically sized so that no more than one batch per day is required to be prepared.

The liquid reagent tanks are contained in bermed areas of sufficient volume to handle the full volume in case of a vessel failure. Non-compatible reagents will have individual bunded areas.

The reagents are distributed throughout the plant via metering pumps or, in the case of lime and cyanide, pumps feeding a pressurized distribution loop. All pumps are provided in pairs, one operating and one stand-by.

17.4 Tailings Filtration Plant Design Criteria

The tailings filtration plant receives Windfall Mill tailings, which are produced at a nominal throughput of 154 tph (3,400 tpd at 92% availability). In addition to the mill tailings, the tailings filtration plant also receives thickened sludge from the underground mine (nominal flowrate between 6.9 tph and 9.7 tph).



The tailings filtration plant design includes a 20% design factor, allowing the plant to process up to 196 tph of solids.

Based on varying mine backfill requirements over the LOM, filtered tailings are planned to be directed to the paste production circuit approximately 39% of the time and to dry stacking about 61% of the time.

A summary of the key design criteria is presented in Table 17-3.

Table 17-3: Tailings filtration plant design criteria

Description	Unit	Value
Tailings production rate - nominal	tpd	3,400
Tailings filtration plant design factor	%	20
Filtration plant capacity - design	tph	196.4
Paste production time over LOM (vs. total)	%	39
Dry stacking time over LOM (vs. total)	%	61
Paste characteristics	-	-
▪ Paste solid content (average over LOM)	%	70.2
▪ Paste binder content (average over LOM)	%	3.11
▪ Paste binder	-	Slag/Cement (90:10)
Dry stack characteristics		
▪ Dry stack solid content	%	84

17.5 Tailings Filtration Plant Process Description

17.5.1 Summary

The tailings filtration plant is located near the mine bore hole, and approximately one kilometre away from the Windfall Mill. It is equipped with three filter presses that process the totality of the mill tailings and sludge from the underground mine. Two are in operation to meet the filtration plant required capacity while one is on stand-by. After filtration, the filtered tailings are directed to either the paste production circuit or to the dry stack storage facility.

Figure 17-6 presents a simplified flowsheet of the tailings filtration plant.

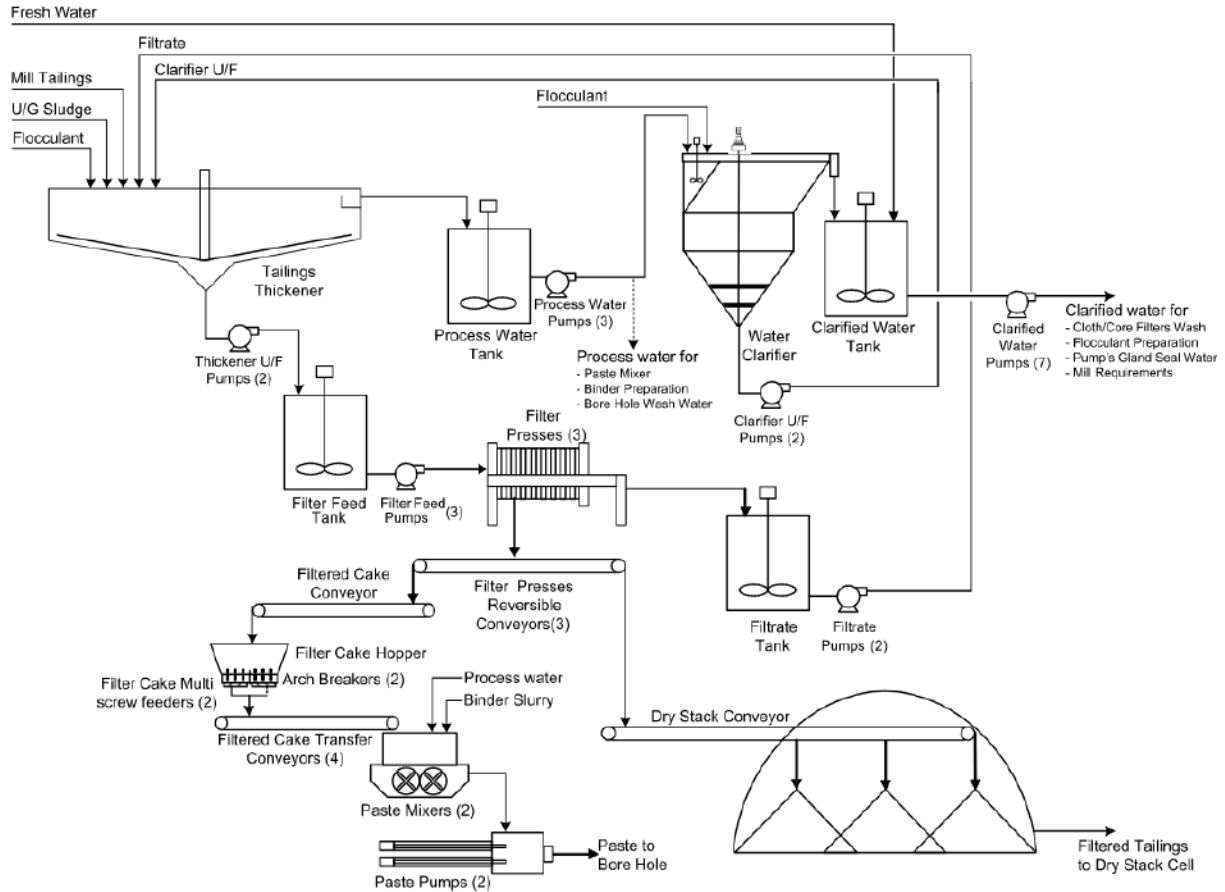

Figure 17-6: Tailings filtration plant simplified flowsheet

17.5.2 Thickening and Water Management

The Windfall Mill tailings slurry is pumped to the 28 m diameter tailings thickener. The underground sludge is also received in the tailings thickener. The thickened tailings have a solids content of 63% with a D_{80} of 37 microns and are stored in the filter feed tank, which is sized to provide a 5-hour residence time. Three slurry pumps (one per filter) are installed to feed the filter presses.

The thickener overflow is collected into the process water tank. Process water is used for the paste and binder preparation. The remaining process water is pumped to a clarifier. The clarifier produces water that is usable for gland water, flocculant preparation and filters washing requirements. The remaining clarified water is pumped back to the Windfall Mill as industrial water. The clarifier underflow is returned to the tailings thickener.

Flocculant is added to both the tailings thickener and the clarifier to assist with solids sedimentation.



17.5.3 Filtration

Two operating filter presses (third press is on stand-by), each with approximately 600 m² of filtration area, are used to produce a cake at a density of 84% solids. Cakes from the filters are then discharged onto reversible belt conveyors where they are sent either for dry stacking or for paste mixing. Clarified water provides core and cloth wash water for the filter press wash cycle. The filtrate, core and cloth wash waters from all three filters are collected into a common agitated filtrate tank, which has a 30-minute storage capacity. As they contain solids, they are pumped back to the tailings thickener.

Three drying air compressors, one pressing air compressor and their designated air receivers service the three filter presses.

17.5.4 Paste Production

For paste mixing, the filter cakes are sent from the reversible belt conveyors onto the filtered cake conveyor. This conveyor discharges into the filter cake hopper which is equipped with two arch breakers. The filter cake hopper can contain the filter cake from two filtration cycles. Following the hopper, the paste production circuit consists of two parallel processing lines, providing redundancy and ensuring continuous paste production and pumping.

Cake from the hopper is discharged using one of the two multi screw feeders. Each feeder feeds a series of two conveyors that continuously transfer the cake to a twin shaft paste mixer, which provides a minimum mixing time of 2.5 minutes. A scale is installed on the first of the two transfer conveyors in each line to control the retrieving rate using the variable speed drive of the multi screw feeders.

Binder slurry and process water are continuously added into the paste mixer to prepare the desired paste recipe. The binder content in the paste is 3.11% with an overall paste percent solids of 70.2%. Paste binder content was calculated based on interpolation of test work results provided by Golder, with an added design factor of approximately 20% (or about 0.5% absolute).

Pre-mixed binder (90:10 slag/cement) is stored in a silo adjacent to the tailings filtration plant and has a 48-hour retention time. The binder is discharged from the bottom of the silo by a screw conveyor which then discharges onto a belt conveyor equipped with a scale. The binder and process water addition rate to the mixing tank are controlled to achieve a binder slurry density of 25% solids.

The paste mixers discharge into hydraulic piston paste pumps to distribute paste to the underground piping network. Only one paste pump is planned to be in operation at any time. The piping network is then purged using process water.



A dust collector and safety showers service the cement storage and preparation area. A mobile high pressure washing unit is available to clean the mixers and paste pumps.

17.5.5 Dry Stacking

For dry stacking, the filter cakes are sent from the reversible belt conveyors to the dry stack conveyor that feeds the dry stack storage facility. The storage facility has sufficient capacity to store 24 h of dry stack. A loader then transfers the dry stack into trucks that transport the material to the tailings management facility.

17.5.6 Reagents and Compressed Air

A flocculant preparation system is installed to provide flocculant solution to the tailings thickener and the clarifier.

The flocculant is received in 25 kg bags and is prepared to a 0.5% concentration solution in a mix tank using warm clarified water. The distribution tank is located underneath the mixing tank and two metering pumps ensure the distribution.

An air compressor provides instrument and plant air to the filtration plant.

17.6 Plant Control System

The following provides a broad overview of the control strategy that will be implemented for the plant.

The operating philosophy for the processing circuits is based on the following fundamental concepts:

- The overall supervisory control of the plant is handled from an Integrated Operations Centre ("IOC") where senior operators can control all the systems and from where metallurgical personnel and supervisors can perform troubleshooting by looking at on-line trend data and operating dashboards.
- The plant is highly automated and instrumented and Ethernet network is used for interfacing electrical equipment using modern industrial communication protocol like Ethernet/IP.
- The plant control philosophy is fully integrated with the entire site control philosophy to enhance communication and collaboration at all levels and provide timely data for analysis and predictive maintenance.

The overall plant operations will be supervised and controlled by a common industrial process control system ("PCS") based on a Honeywell Direct Control System ("DCS") platform, while



enabling fast exchange of digital data used for motor protection and status, and handling sequences and batch operations.

An information system and an information management system allow certain staff members to monitor the process and variables from their personal computer (“PC”) connected to the management information platform.

Virtual machines will be used to host all control system software (e.g. historian, configuration tools, etc.). These virtual machines will be managed through redundant virtual machine (“VM”) servers supporting rapid failover to minimize downtime.

A generic description of the proposed control system topology is presented in Figure 17-7.

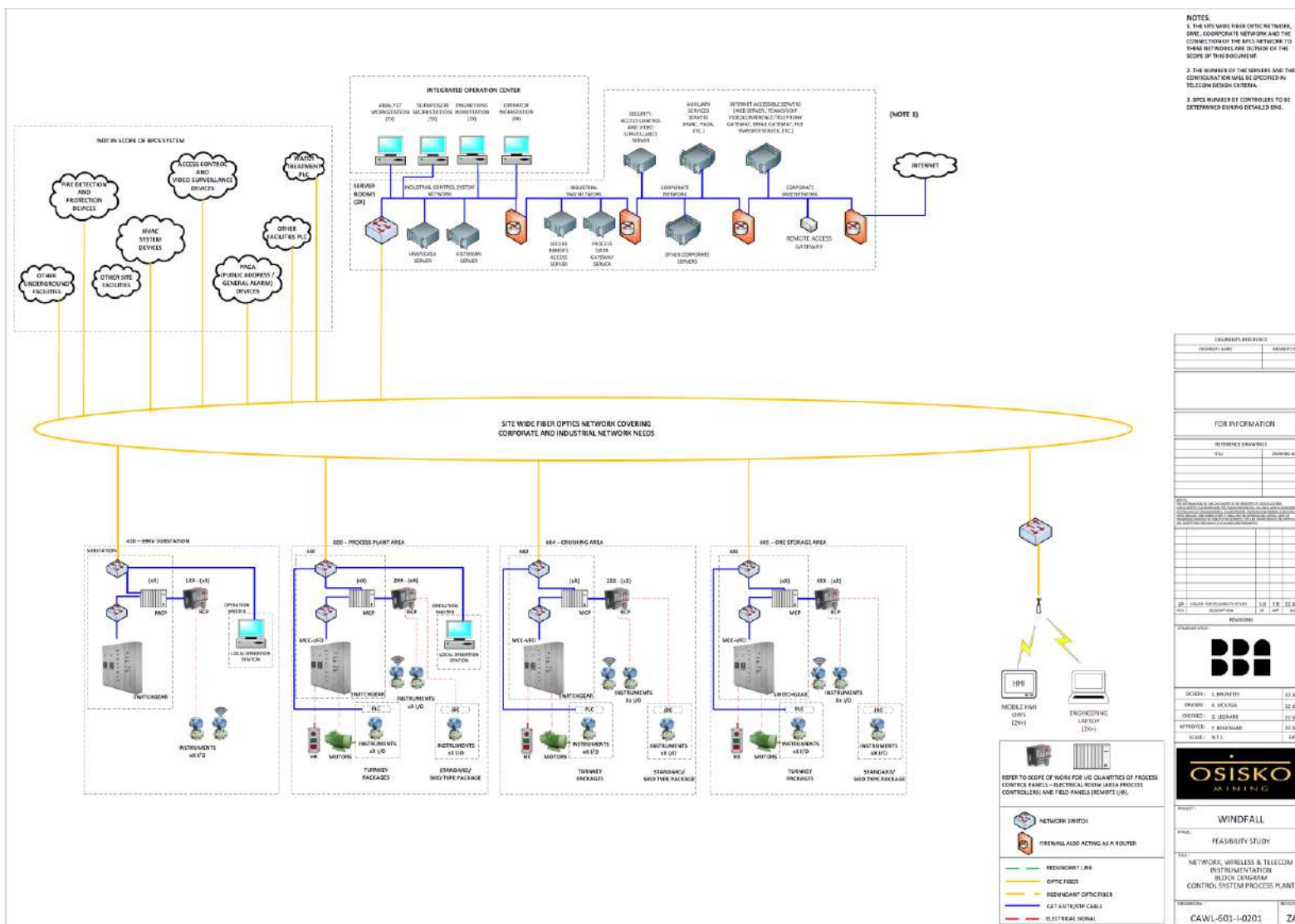

Figure 17-7: Proposed control system topology



18. Windfall Project Infrastructure

18.1 General

The Windfall Project is located 115 km east of Lebel-sur-Quévillon, in the Eeyou Istchee James Bay Territory. An existing gravel road for lumber transportation from Lebel-sur-Quévillon is already used for site access. The Project location is shown in Figure 4-1.

The Project benefits from existing infrastructure developed during the exploration stage. Some of the existing components will be improved or increased in capacity and will be considered in the design of the required infrastructure for the Project, as listed below.

Mining infrastructure is planned around the existing exploration ramp and waste rock/overburden stockpiles.

The Windfall Project considers the following buildings and site infrastructure as existing:

- Windfall site access road;
- Main zone portal with underground mine services (compressed air, electricity, ventilation intake);
- Waste rock stockpile;
- Surface water management ditches, ponds, and pumping stations;
- Water treatment plants;
- Exhaust raise and fan;
- Hybrid secondary WAN link (fibre optic and microwave radio);
- Light structure, fabric-covered domes;
- Meteorological station;
- Borrow pit;
- Diesel generators;
- Telecommunication tower and private LTE system for the surface and underground mine.

The following elements are considered separate from the Project, as they are led by subsidiaries of the Cree First Nation of Waswanipi ("CFNW"), the main one being Miyuukaa. CFNW will be responsible for constructing and supplying the following electrical infrastructure required by the project:

- MICO step-up substation (25 kV to 69 kV) to interconnect with Hydro-Québec Waswanipi substation;
- 69 kV overhead transmission power line and MICO substations;
- Windfall step-down substation (69 kV to 13.8 kV) located in the vicinity of the Windfall Project;
- Fiber optic WAN link to Waswanipi as optical ground wire ("OPGW").



The following existing infrastructure is considered outside the scope of the Feasibility Study, but remains in use for exploration:

- 300-person capacity exploration camp complex, including potable water and sewage systems;
- Helipad;
- Core logging buildings;
- Storage domes;
- Overhead power lines and camp area genset.

The Project will require new key infrastructure as follows:

- Process plant complex including crushing line, offices, dry and warehouse;
- Tailings filtration and paste backfill plant;
- Camp complex including dormitories, cafeteria and dining room, fitness and game centre, welcome centre, and laundry facilities;
- First Nations cultural centre;
- Potable water and sewage management systems;
- Gatehouse;
- Truck shop;
- Production core shack building that will also house the emergency vehicles;
- Extension of the existing waste rock stockpile;
- Overburden stockpile;
- Ore stockpile;
- Tailings storage facility;
- Surface water management facilities, including ditches, ponds, pumping stations, and piping;
- Site service and hauling roads;
- Borrow pits;
- Materials laydown and storage area;
- Domestic waste management storage area;
- Lynx zone portal with underground mine services (electricity, ventilation intake, fuel distribution);
- Exhaust raises and fans;
- Fire protection water storage, pumping stations, and distribution systems;
- Diesel, gasoline and propane storage and distribution systems;
- Upgrades to the existing water treatment plant;
- Overhead 13.8 kV power lines;
- An additional telecommunication tower;
- A local Integrated Operations Centre;



- Rental of off-site administration offices and project warehousing in the region; location is yet to be determined.

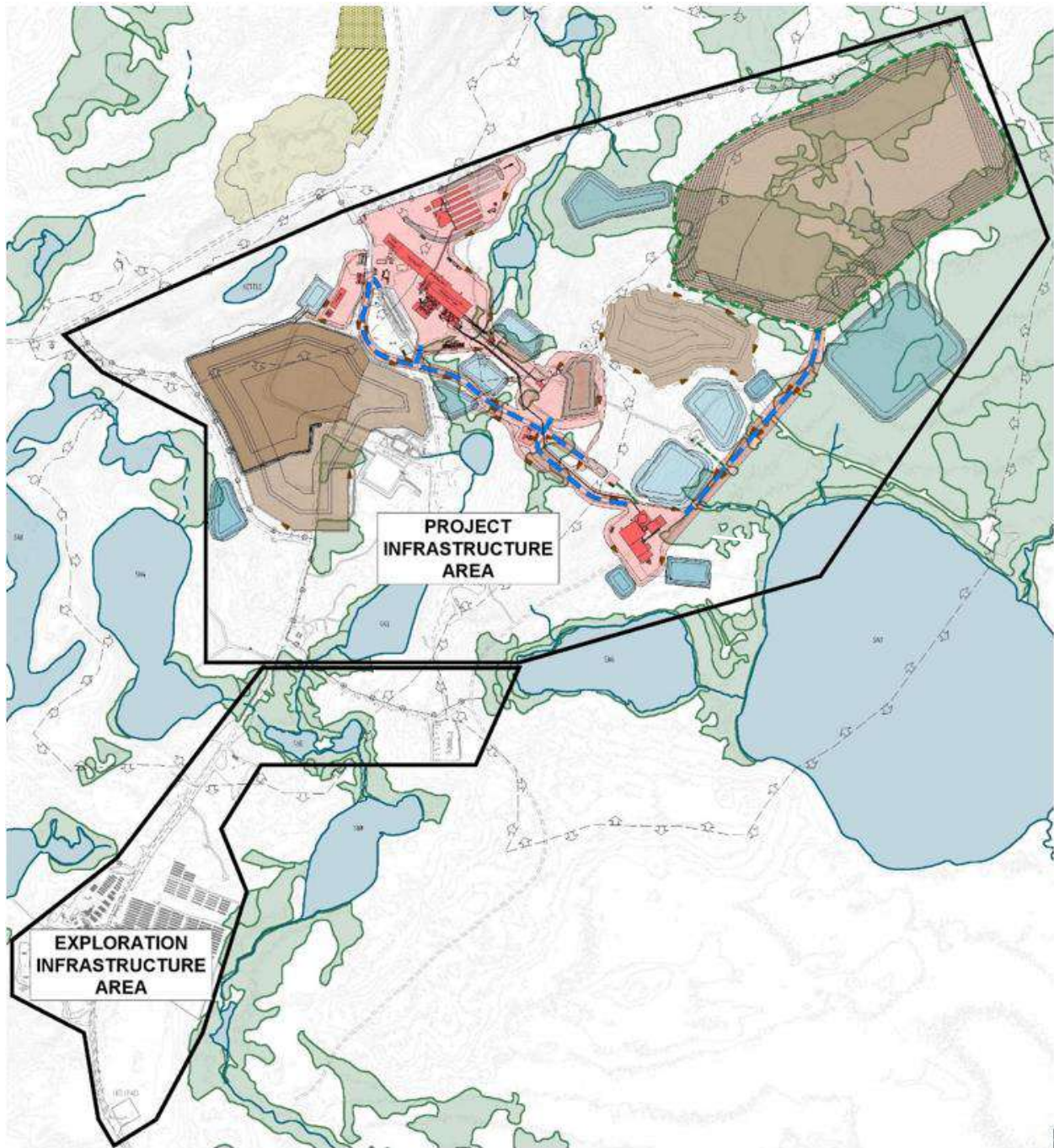

Figure 18-1: Windfall complete site layout

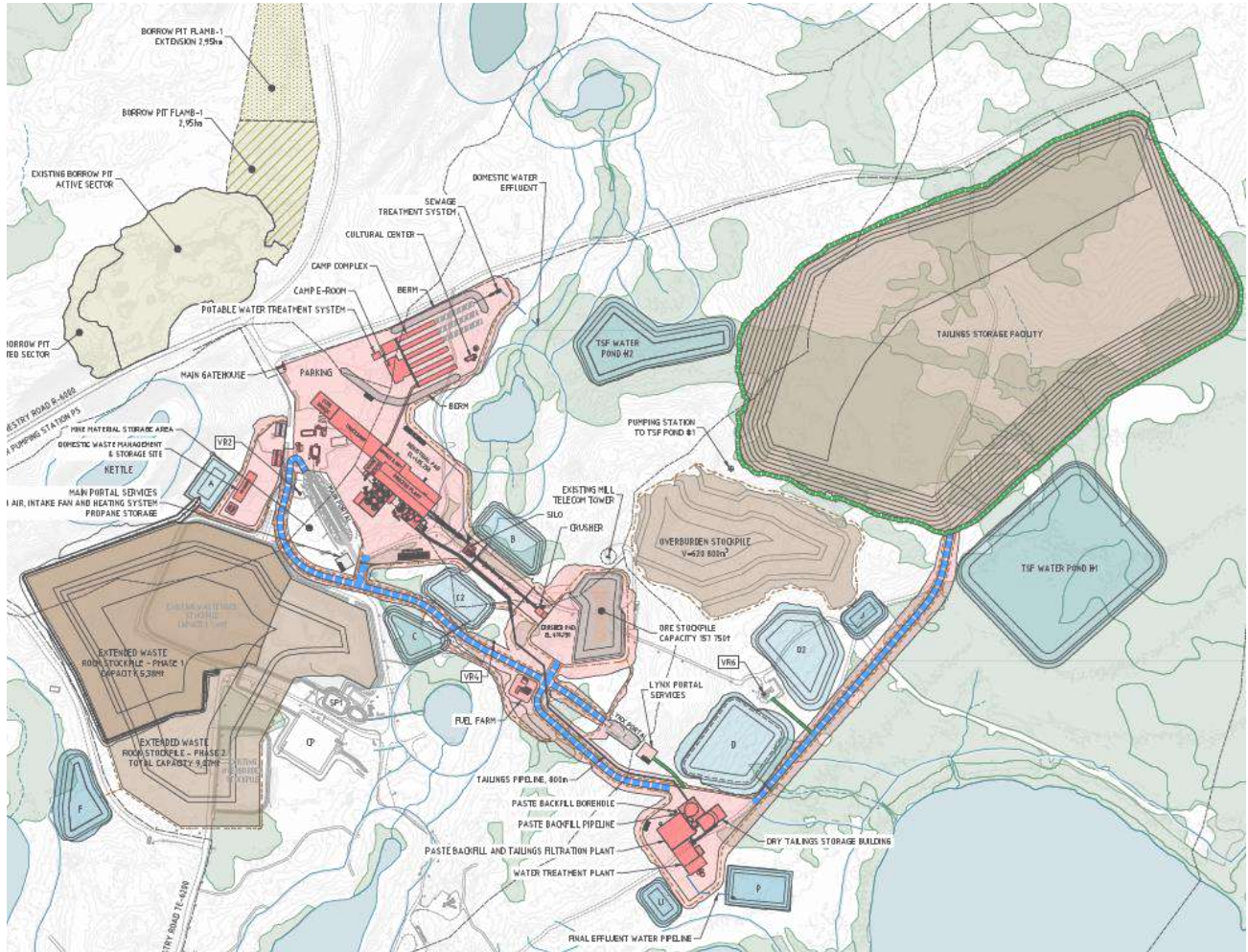

Figure 18-2: Windfall Project layout

18.2 Off-site Access Road

The Windfall Mine Site is currently accessible by a 115-km gravel road that branches off the Chemin du Moulin road, southeast of Lebel-sur-Quévillon. Access is primarily by a Grade 1 forestry road (10 km R-1000, 55 km R-5000) and 47 km of Grade 2 forestry road (R-6000) (see Table 18-1). The Grade 1 road was built as a main road for transporting oversized commercial timber in the early 1990s and was eventually extended with a Grade 2 road to access new land to access lumber in the Windfall site area. A bridge, the Wetetnagami River Bridge (R0853-03), is located on R-5000 at km 62. Its capacity is 138 tonnes.



An inspection of the access road was conducted in July 2022 and an inspection report was issued (WSP, 2022b). In summary, the report states that the roads are generally in good condition and do not require immediate major improvements.

Table 18-1: Windfall off-site access road details

Section	Description	Length (km)	Width (m)	Grade	Capacity (tonnes)
1	R1050 (R-1000)	10.0	10.5	1	138
2	R0853 (R-5000)	55.0	10.5	1	138
3	R1053 (R-6000) / SE-6000.00	47.0	10.0	2	138

18.3 Site Preparation

Whenever possible, existing pads and roads will be used for both the construction and operation phases to reduce environmental impacts and required deforestation, clearing and grubbing.

The construction sequence will consider optimal usage of excavated material as backfill for surrounding infrastructure. All vegetal soil will be stored on the overburden stockpile until the closure phase, when it will be reused.

The aggregates (MG-20, MG-56, MG-112, sand, rip rap, and 0-600 granular material combined) required for construction will be extracted from the borrow pits identified north of the site and prepared by a mobile crushing and screening unit planned to be installed in the existing borrow pit during the construction phase. Road maintenance material will come from these borrow pits as well.

Table 18-2: Windfall borrow pits identification

Pit	Description	Distance (km)	Area (ha)	Depth (m)	Capacity (m ³)	Details
1	Flamb-1 extension	<1	2.96	4	118,244	Mostly sand expected, no samples analyzed
2	Gravtest-3	3	9.86	3.5	345,140	Good quality, sand and pebbles
3	Gravtest-4	5	10.70	5	535,040	Good quality, sand and pebbles



18.4 Geotechnical Studies

Regional surface deposits consist of fluvio-glacial sediments and glacial till. Fluvio-glacial sediments are mainly composed of sand and gravel and are located in the northern and western parts of the site, whereas the till is found at the surface in the eastern sector of the site and below the fluvio-glacial sediments in the northern and western areas of the site. The glacial till deposit located on-site is a heterogeneous glacial unit and is encountered just above the bedrock contact.

A total of 190 geotechnical boreholes and 22 test pits were completed across the site (WSP, 2022 a, c, d, e, f, g, h, i; Golder 2022a) on top of the 69 previously-drilled boreholes (Genivar, 2008, Golder, 2018). During these geotechnical campaigns, lithologies were identified, in-situ tests were completed, and samples were collected for laboratory characterization.

With the exception of the southeastern section of the TMF and the two TMF ponds, and based on the geotechnical information collected from the boreholes, the site stratigraphy generally consists of:

- Organic layer with a variable thickness up to 2 m;
- Sand layer consisting generally of a fine- to medium-grained sand with traces of gravel and silt. The sand layer varies from loose to compact in the upper portion, becoming dense with depth and approaching bedrock. The thickness varies from 1 m to 8 m;
- Bedrock.

Water levels were measured between 1 m to 6 m below ground surface; they were measured in August and May when water levels would be at the lowest and highest.

For the southeastern section of the TMF and sectors of the two TMF ponds, site conditions are different. The sectors are located on a wetland and are characterized by a thicker overburden deposit (Golder, 2022a). The particularities of the soils in this area compared to foundations elsewhere on-site are as follows:

- Thickness of the organic layer up to 2 m (about 1.5 m in average);
- Thickness of the granular deposit up to 37 m;
- Presence of discontinuous silty layers within the granular deposit;
- Bedrock.

The water table is generally high and is located just above the interface between the topsoil layer and the native sand deposit. Granular soils were identified as generally loose in this specific area.



18.5 Site Access Control

The main modular gatehouse building will be located at the entrance of the site, at the junction of the industrial pad and at the end of the main access road. Gatekeepers will be able to track personnel on site and delivery of materials. The gatehouse will be equipped with a surveillance camera system and an intercom system.

18.6 First Aid / Mining Rescue

A first aid room will be provided in the process plant office area. The reception room of the infirmary will be on the ground floor with a double-door for the reception of the ambulance.

A mining rescue room will also be located on the ground floor close to the infirmary.

There will be a fire truck permanently on site, parked in the core shack building.

18.7 Camp Complex Area

The camp area will include the camp complex as well as the First Nations cultural centre, which will be installed near the camp.

The camp complex will be made up of prefabricated modular-type units installed on steel tripods and will include the following blocks: dormitories, cafeteria and dining room, fitness and game centre, welcome centre, and laundry facilities. Each block will be supplied with the required services: potable water, sewage, electricity, propane, and fire water (cafeteria and dining block only). Each block will include propane gas fired heating units for crawl space and water heaters with storage tanks and recirculation pumps. The camp complex layout is shown in Figure 18-3.

There will be six aisles of dormitories, two-stories each, for a total of 406 individual executive rooms each equipped with a double bed. Each dormitory aisle will include a laundry room, a house keeping room, a mechanical/electrical room, and staircases.

The cafeteria and dining room will allow for food preparation, storage and service for the personnel on site. This area will also include a hand wash station, a coat room, washrooms, offices, garage doors for the receiving area, a mechanical room, and a refrigerated waste room. The cafeteria and dining room area will be equipped with sprinklers and a commercial exhaust hood with fire protection for safety.

The gym/fitness and game room will include gym/fitness equipment and changing rooms.

The welcome centre will accommodate workers at the Windfall site upon arrival. The offices of the camp logistics staff are also in this building. A waiting room will be set up to allow workers completing their rotation to gather before the arrival of the bus. A long-term luggage storage room, and a first aid room along with a convenience centre will also be available.



Laundry facilities will include commercial dryers and washers and will be equipped with carts, and a garage door.

All blocks will be linked together by enclosed and heated modular corridors. Also, a similar corridor will allow access to the office area of the process plant.

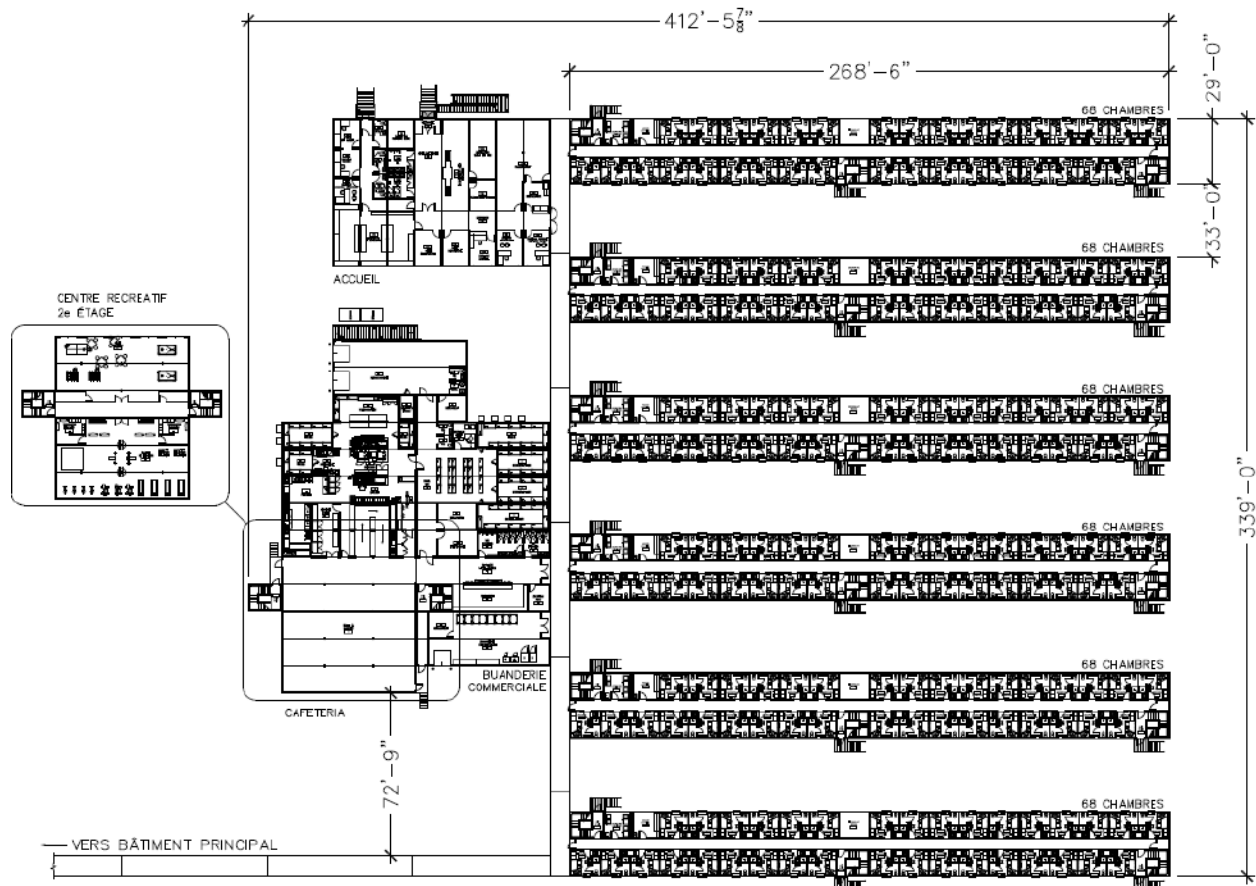

Figure 18-3: Camp complex layout

The First Nations cultural centre near the camp will include a meeting space and various areas where traditional activities can be undertaken. A library, bathrooms, a coat room, and a kitchen with an adjacent wood stove will be available for cooking traditional food. A teepee will be installed next to the house with a diameter of 10 m at the base and will be made of wood pieces that join in the centre, covered with a waterproof canvas, as per traditional construction techniques.

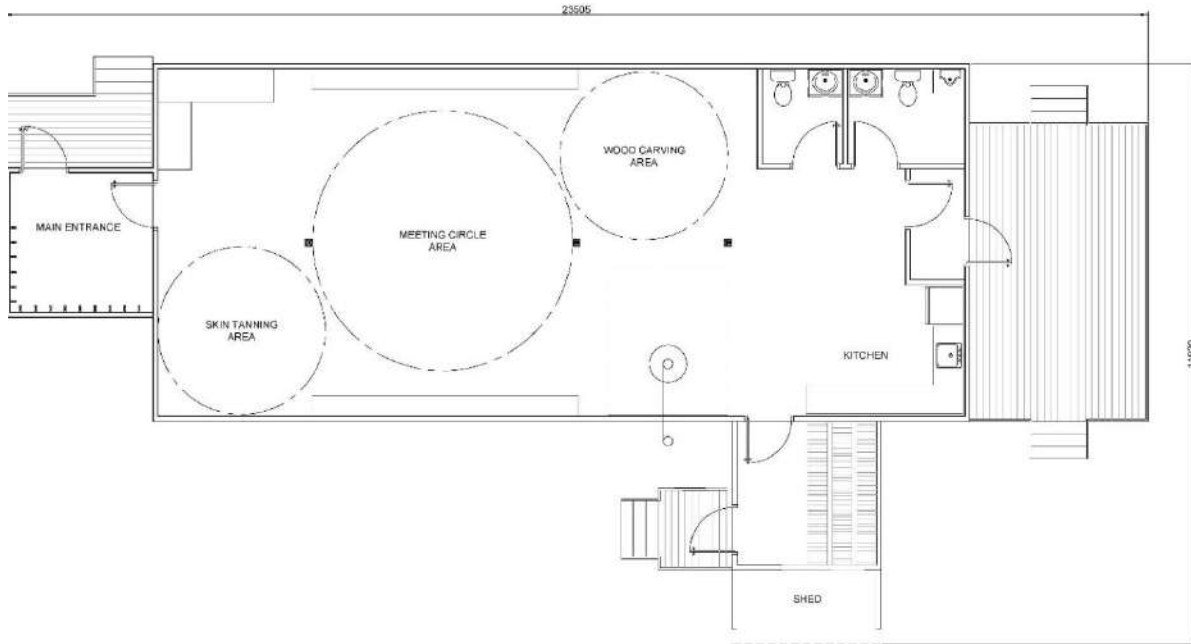

Figure 18-4: First Nations cultural centre layout



Figure 18-5: Traditional teepee image



18.8 Bulk Explosives Storage and Magazines

All explosive materials and magazines will be stored directly in the underground mine.

18.9 Fire Water System

A fire protection pumping station with a flow capacity of 454 m³/h will include an electrical pump with a diesel backup pump, jockey pumps, piping, and instrumentation to feed a buried piping network connecting to the site hydrants, the process plant, the truck shop, the production core shack, the filtration plant, and the cafeteria. The fire water tank will be stored in a reserved portion of the process plant's raw water tank, so the pumping station modular building will be adjacent.

The fire protection system and sprinklers will be installed in each building to meet legal and insurance obligations. Wall outlets for fire protection are planned around the process and maintenance buildings. Manual fire extinguishers will also be installed in the buildings, according to code requirements.

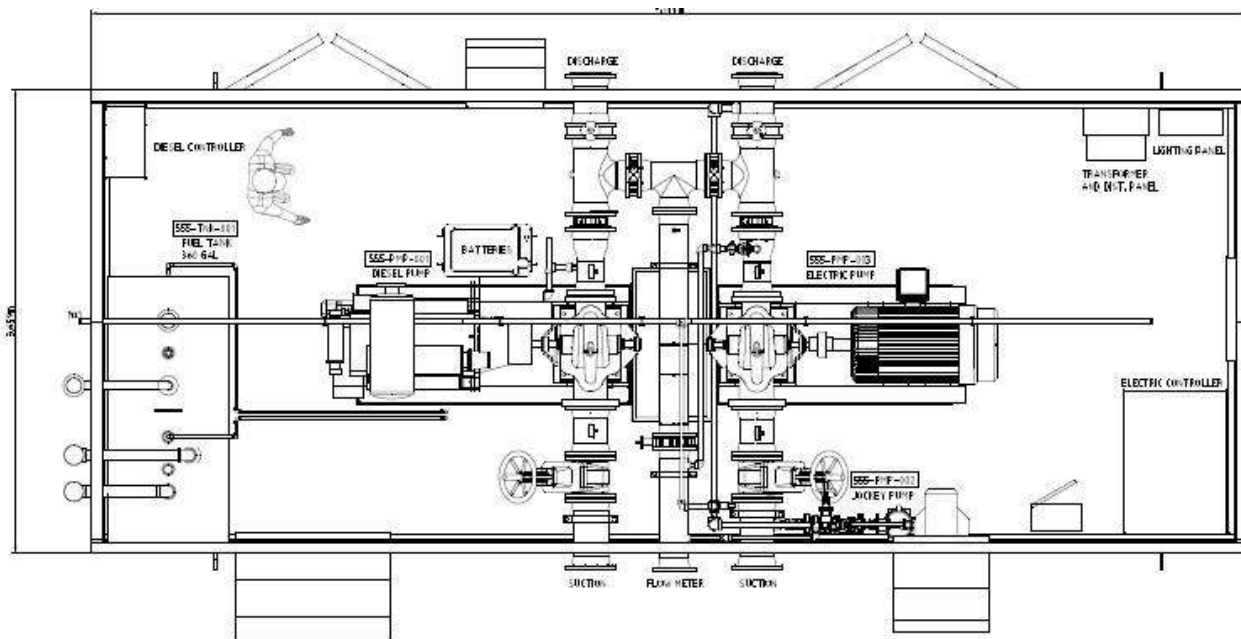

Figure 18-6: Fire water pump station layout



18.10 Site Lighting

Roadway lighting will be limited to minimal requirements at intersections. There is an overhead line along the road, and a single-phase transformer will be installed if needed; however, power will be sourced from adjacent buildings where possible.

Exterior lighting will be present in pedestrian areas and work/storage areas. Dedicated exterior lighting will be installed on buildings at all garage doors or man doors. For all exterior lighting, LED fixtures will be used to reduce maintenance time. Photocells will be installed to reduce power consumption.

18.11 Truck Shop

A 3,715-m² truck shop will be adjacent to the process plant for heavy equipment and light vehicles maintenance. There will be five bays dedicated to the maintenance of heavy equipment, four bays for light vehicles, one enclosed wash bay, one enclosed welding bay with mobile fumes extractor, and a dedicated bay for the exploration material and drills. All heavy equipment garage doors will be roll-type to maximize inside working space.

A 10-ton overhead crane equipped with two hooks will be installed in the heavy equipment maintenance area, while a single 10-ton overhead crane will cover the light vehicle area. Other maintenance equipment will be available for the mechanics.

Various rooms will be built on the first floor, including a tool crib, an oil and grease deposit with a carousel distribution system, an electrical room, storage rooms, and a foreman office. The second floor will include bathrooms, locker rooms, a dining room, a meeting room, a mechanical room, and offices.

All water on the truck shop floor will be collected to an oil separation system with an integrated coalescent filter to ensure efficiency even if emulsification occurs. A sand pre-separator is included in the wash bay.

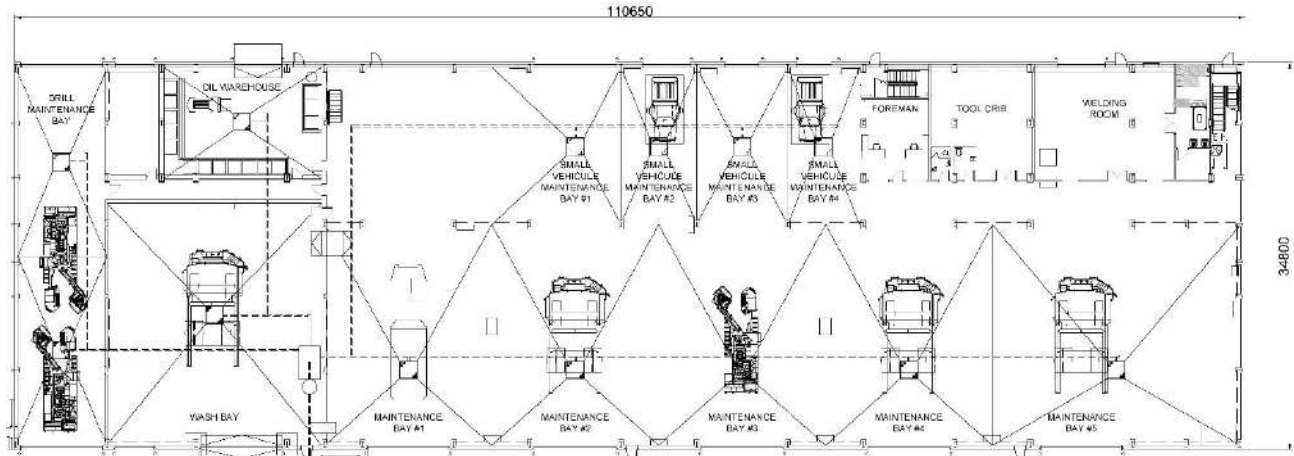

Figure 18-7: Truck shop layout (first floor)

18.12 Mobile Equipment – Surface

The mobile equipment procurement and operation strategy for the surface maintenance, tailings handling, and other vehicles will combine the contractor and Windfall needs. Table 18-3 provides the list of the planned surface mobile equipment with suggested models as reference.

Table 18-3: Mobile equipment list

#	Description	Qty	Suggested model	Role
1	Pick-up truck	14	RAM 2500	Construction & site supervision
2	Grader	1	JD 772G	Site maintenance
3	Loader	1	WA 320	Core shack and Site support
4	Water truck	1	TA 400	Site maintenance
5	Loader	1	WA 600	Process Plant
5	Loader	1	WS 380	Surface infrastructure support
7	Bulldozer	1	D8T	Dry tailings management
8	Loader	1	WA 500	Dry tailings loading
9	Articulated haul truck	2	740	Dry tailings transportation
10	Bulldozer	1	D6	Dry tailings management
11	Hydraulic excavator	1	PC 360	Dry tailings management
12	Hydraulic excavator	1	320	Site maintenance
13	Compactor	1	DH 5	Dry tailings management
14	Forklift	1	P 6000	Process plant and warehouse
15	Skid steer Loader	1	2424D3	Process plant cleaning



#	Description	Qty	Suggested model	Role
16	Stand-up lift	1	7300	Warehouse
17	Ambulance	1	Chevrolet	Emergency
18	Fire truck	1	Volvo WCN	Fire protection
19	Emergency vehicle	1	40S	First responder
20	All terrain	1	Outlander	Site supervision / emergency
21	Snowmobile	1	Skandic	Site supervision / emergency

18.13 Fuel Storage and Distribution

A fuel bay will regroup the diesel and gasoline storage on site, located at a central position to supply underground mine trucks, dry tailings transport trucks, and other vehicles. There will be four 45,000-litre diesel tanks and one 10,000-litre tank for gasoline.

Both systems include double-walled vacuum tanks for leak prevention and sealing, verifiable by pressure control. The tanks include level monitoring sensors and a distribution management console. Near both gasoline and diesel distribution systems, a reinforced concrete slab will be installed next to the pump to accommodate trucks during fill up and to facilitate clean-up in case of a spill.

For the propane storage and distribution, the tanks and vaporizer will be located near the consumer. Each tank perimeter will include bollard for protection and will be connected to the building via buried piping. Table 18-4 shows the locations and capacities of the propane tanks.

Table 18-4: Propane storage tanks

Item	Description	Capacity (litre)	Capacity (usg)
1	Process plant	151,400	40,000
2	Camp complex	75,700	20,000
3	Truck shop and core shack	75,700	20,000
4	Main portal air intake heater	75,700	20,000
5	Lynx portal air intake heater	75,700	20,000
6	Tailings filtration and water treatment plant	75,700	20,000
	Total	529,900	140,000



18.14 Production Core Shack and Emergency Vehicle Storage

The production core shack will be a 1,400-m² building annexed to the truck shop and will also house the emergency vehicles. The expected emergency vehicles include a fire truck, an ambulance, a snowmobile, an all-terrain vehicle, and a first aid and environmental spillage recuperation equipped pick-up. Next to the storage area, a meeting room and a safety equipment storage room will be accessible. The building layout is shown on Figure 18-8.

The core shack area will include worktables and centralized core racks. A core splitting insulated room with carousel-type hydraulic saws will be provided, as well as a shipping/receiving area, a storage area, offices, open-space desks, electrical room, eye-wash station, and restrooms. The anticipated core preparation and logging capacity is 1,800 m of core samples per day, based on 12-hour shifts.

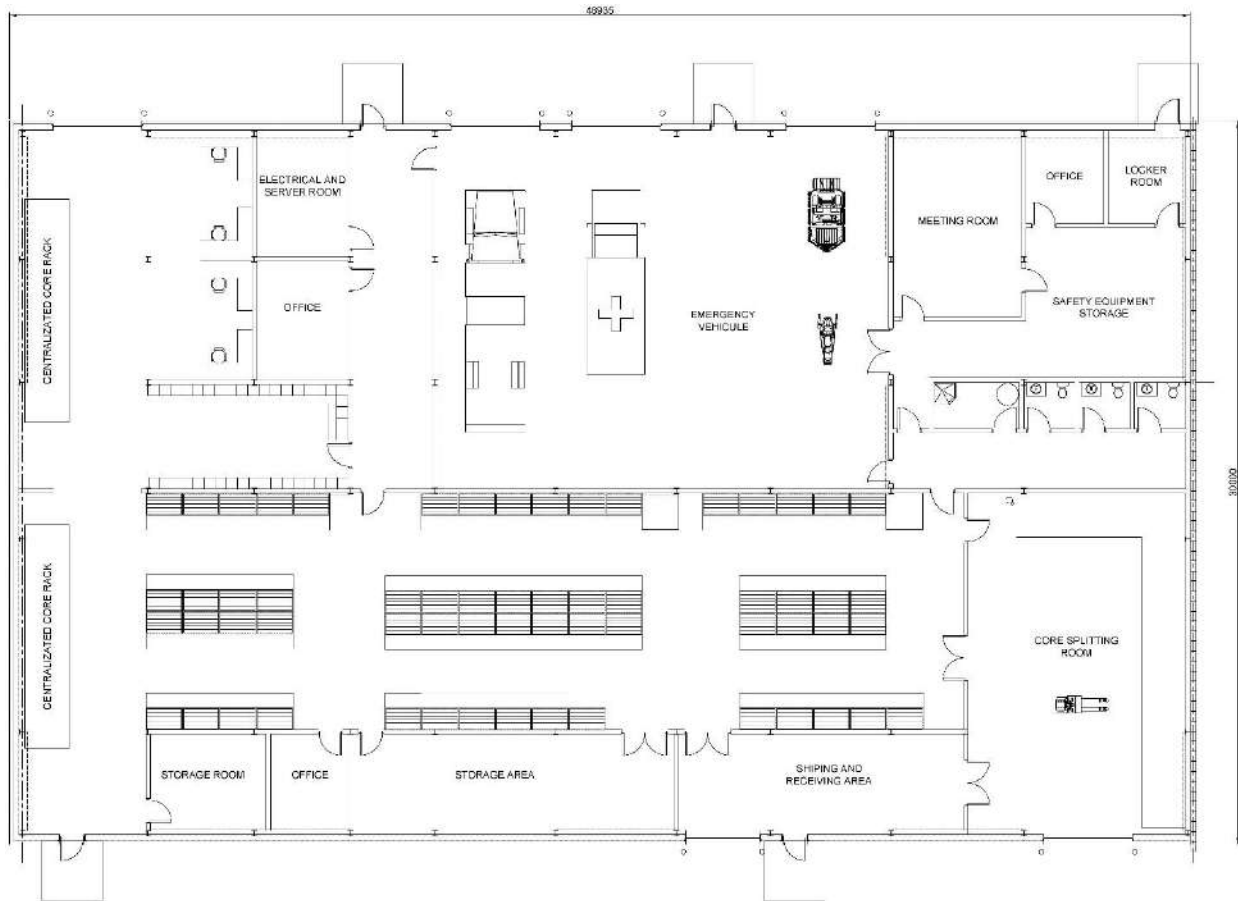

Figure 18-8: Production core shack and emergency vehicle storage layout



18.15 Domestic Waste Management and Storage

The waste management strategy involves regular transportation of waste by a specialized contractor from the site to authorized sites. Temporary collection and dedicated storage systems by waste category will be set up to facilitate loading onto trucks and transport to authorized sites. The waste categories are presented in Table 18-5. Appropriate bins and containers will be provided on site to allow sorting of waste materials. Some of the equipment already in use at the exploration site will be relocated to the new waste management area (composter, compactor, bins, and containers).

Table 18-5: Waste material categories

Waste Material Category	Description
Recyclable Material	Paper, glass, plastic, metal.
Compostable Material	Cafeteria food waste, carcasses, expired food.
Hazardous Household Waste ("HHW")	Antifreeze, solvent, aerosol, paint, fluorescent bulbs, lamps, batteries, smoke detectors.
Waste Oil, Grease and Oily Water	Various, from mechanical workshops.
Construction, Renovation and Demolition Debris	Wood, aggregates, various composite objects that end up in the final waste
Ultimate Waste	Bulky waste, litter bags, polystyrene foam, packaging, sanitary fabrics, composite objects, contaminated objects, non-recyclable plastic, rubber, ashes, process waste, various empty containers.
Septic Tank Sludge	Excluded from residual materials. Tanks are emptied frequently by a specialized pump truck service.
Contaminated Soils	Excluded from residual materials. Refer to the Land Protection and Rehabilitation Regulation for the management of contaminated soils.
Biomedical Waste	Excluded from waste materials. Refer to regulation for the management of the site's medical service.

18.16 Potable Water

The raw water for the Windfall site will be supplied by an underground water well P5, which is located approximately 1.1 km away from the potable water production unit. The pumped raw water is considered of good quality but requires treatment for the removal of iron and manganese (green sand filters), as well as chlorination before its distribution through the aqueduct network.



For the potable treatment process, a pre-assembled unit is considered. The drinking water production system will be located at the entrance of the site, in four prefabricated units. Two underground tanks will be used to store treated water before its distribution.

The preliminary design of the system is based on the various uses planned for the camp and other infrastructure. It offers a capacity adjusted to an occupancy which will also support the construction phase. The estimated average daily flow is 135 m³/d, with an hourly peak at 50 m³/h and a daily peak estimated at 270 m³.

18.17 Sewage Treatment

The sewage water generated by the future Windfall site will be sent to the treatment system through an underground sewer network that includes gravity pipes, two pumping stations and discharge pipes.

The wastewater treatment technology considered is a membrane bioreactor system supplied pre-assembled cylindrical prefabricated building. The recommended technology will reduce the incoming organic load and suspended solids to the regulatory standards. Furthermore, the addition of coagulant will allow for the removal of phosphorus required for discharge to the environment. Overall, the proposed system will respect the environmental requirements.

The preliminary design of the wastewater treatment system is based on the different uses planned for the camp and other infrastructure, the unitary wastewater flows prescribed by the MELCC in its *Guide pour l'étude des technologies conventionnelles de traitement des eaux usées d'origine domestique*. The design flow considered for the treatment equipment is 118 m³/d.

18.18 Process Plant

The process plant area will consist of three main buildings, the process plant being divided into two areas as listed in Table 18-6.



Table 18-6: Process plant buildings

Description	Width	Length	Height
1. Crushing Building			
Primary crusher	12 m	23.5 m	17.5 m
2. Crushed Ore Storage and Handling Building			
Crushed Ore storage silo	17 m	21 m	33 m
3. Process Plant Building			
a) Process Area			
Grinding and gold recovery	34.8 m	126 m	28 m
b) Services and Office Area			
Service Mechanical room, workshop, electrical room and gold room	18 m	92.4 m	12.5 m
Office and dry Infirmary, laboratory, mine and plant dry, lunchroom, offices.	24 m	57.6 m	15.2 m
Warehouse, control centre, HVAC room, electrical room and training room	34.8 m	24 m	15.2 m

18.18.1 Crushing Area

The crushing area will contain the rock breaker, vibrating grizzly, feeders, jaw crusher, air compressor, an electrical room and a sacrificial conveyor. An overhead crane will allow for maintenance of the equipment. A local dust collector will ensure proper dust management in the area.

18.18.2 Crushed Ore Storage and Handling Area

Crushed ore will be stored in a funnel-flow type silo that has a flat bottom followed by a mass-flow hopper. Feeders will be inserted in the building as well as discharge chutes. A local dust collector will ensure proper dust management in the area. A local prefab electrical room will be installed close to the silo.

18.18.3 Process Plant Area

A plan view of the process plant building area is presented in Figure 18-9.

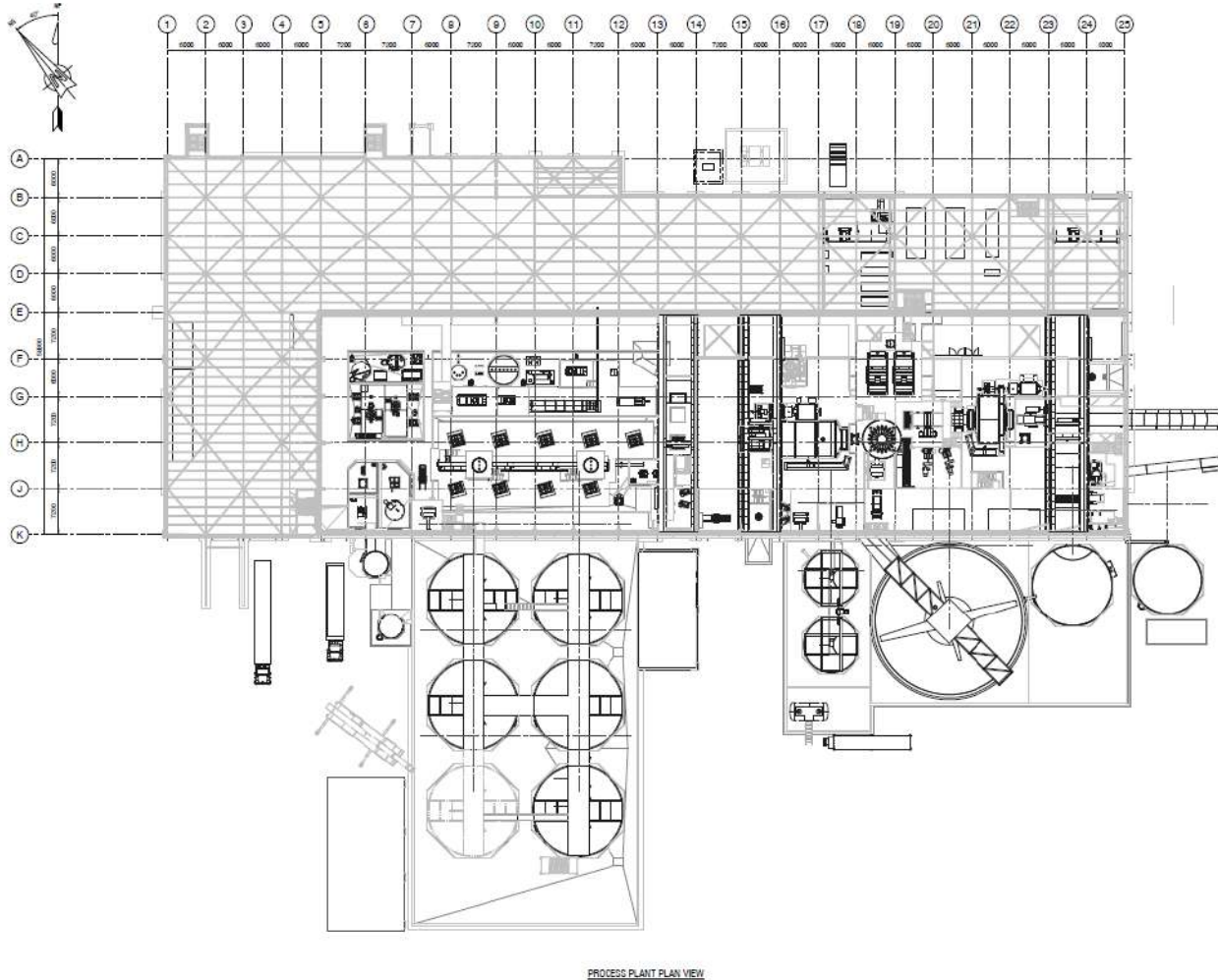

Figure 18-9: Plan view of the process plant

The grinding area will contain the SAG and Ball mills, along with the cyclone cluster, gravity circuit, pebble crusher, intensive leach reactor, and process water tanks. This area will be serviced by two overhead cranes with enough capacity to lift the heaviest mill parts.

The gold recovery area will contain the carbon in pulp carrousel system, the carbon stripping circuit and the reagent preparation areas. This area will be serviced by a third overhead crane using the same rail system as the grinding area.

The pre-leach thickener, leach tanks, cyanide destruction tanks, cyanide tank, lime silo, oxygen plant, SO₂ system, dry reagents storage warehouse and the fresh/fire water tank will be located outside of the process plant.



18.18.4 Office Area

The administrative, mine and process offices will be located west of the services section of the main building.

The area holds administration offices with some closed offices. Conference rooms, a server room, a training room, a mine rescue room, a dispatch room, an infirmary, two cafeterias, bathrooms, process plant laboratory, and mine and process plant dry room are also located in this building.

Figure 18-10 and Figure 18-11 show the general layout of the different areas.



Figure 18-10: Plan view of the mine and process dry layout

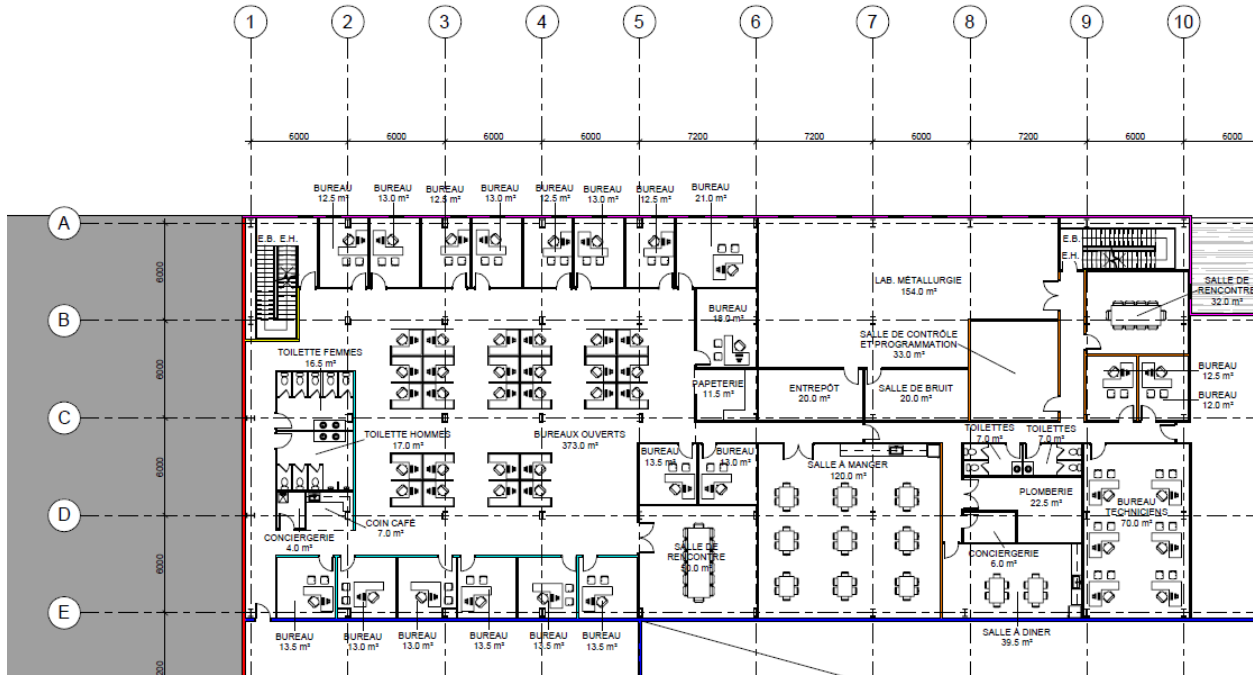

Figure 18-11: Plan view of 1st floor office

18.18.5 Warehouse and IOC Control Centre

The warehouse, centralised Integrated Operations Centre ("IOC"), training room and service room will be located south-west of the main building. The warehouse will be at the ground floor level with access from the process plant and truck shop. The control centre will be located above the warehouse with a view on the process plant. Figure 18-12 shows the plan view of warehouse and the control centre.

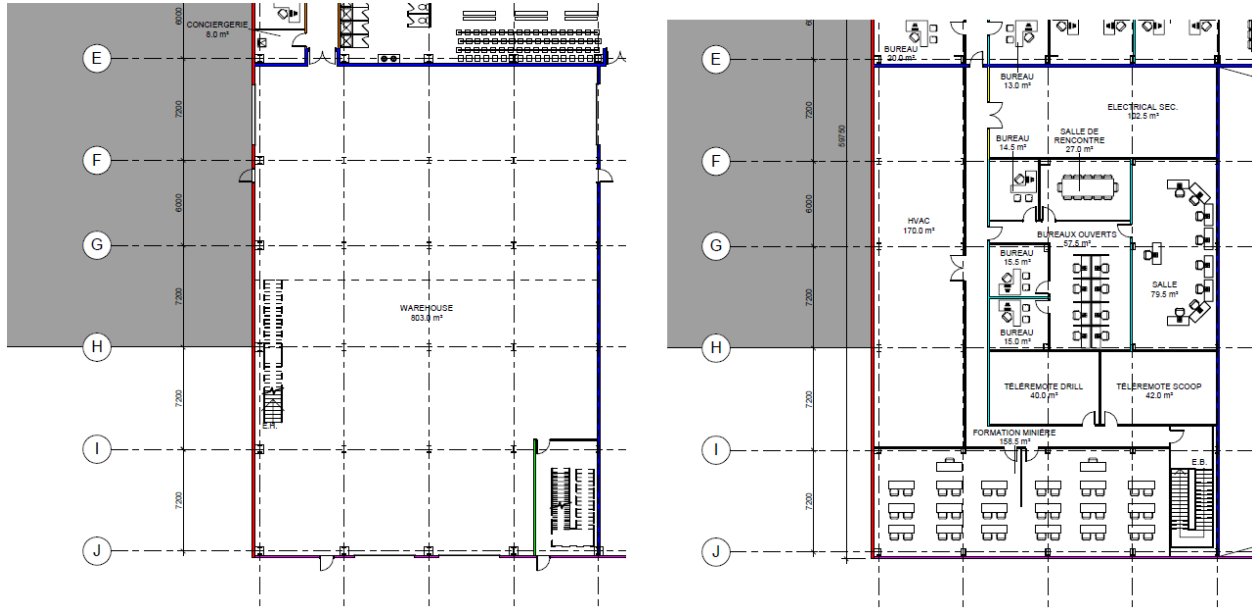

Figure 18-12: Plan view of warehouse and control centre

18.18.6 Tailings Filtration and Paste Backfill Plant

The tailings filtration plant will be located less than 1 km southeast of the process plant building. The area will be 48.8 m wide x 55.8 m long and 67.5 m high. A dry stack storage building of 28 m wide x 51 m long x 18 m high, including the circulating area for truck loading, will be located east of the plant. An isometric view of the tailings filtration plant and dry stack storage is shown in Figure 18-13.

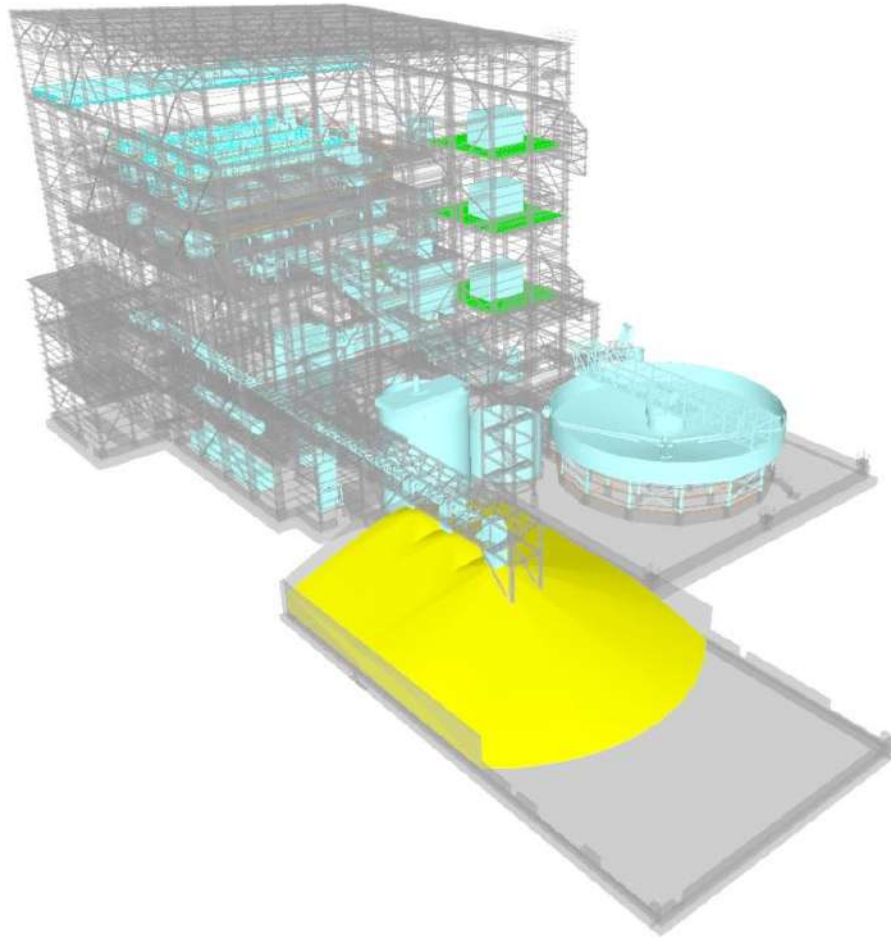

Figure 18-13: Tailings filtration and paste backfill plant layout

Tailings from the process plant and sludge from the underground are sent to a thickener located outside the building. The tailings filtration plant area will house the filter presses and control room, paste mixers, two positive displacement pumps, a water clarifier, a compressor room, conveyors, feeders, tanks and pumps, a flocculant system, a paste backfill laboratory, a mechanical shop, an electrical room, and a lunchroom. The process water tank, tailings filter feed tank and the tailings thickener will be located outside the building surrounded by a 1.6-m high containment wall. The paste backfill binding material silo will also be located outside the building.

Fire protection will be installed over hydraulic units, conveyors, control room, compressor mechanical shop and lunchroom.



The dry stack storage area is in a dome-style building constructed adjacent to the tailings filtration plant building. This area has a storage capacity of approximately 24 hours and can be accessed by mobile equipment (dry tailings transport trucks and front loader).

The tailings filtration plant uses a clarifier to produce clean water for its internal requirements. Fresh water from Pond D or P feeds the filtration plant clarified water tank and is pumped to the process plant to meet its clean water needs.

18.19 On-site Roads

Where possible, the reuse of roads prepared for exploration work is prioritized, with some portions being overhauled.

18.19.1 Service Roads

For site operations, 5 m wide service roads will be built to allow material delivery and access for operation or inspection of the stockpiles, ponds, ventilation raises and other infrastructure. Contact water from the roads will be collected in ditches and ponds, then pumped to the water treatment plant.

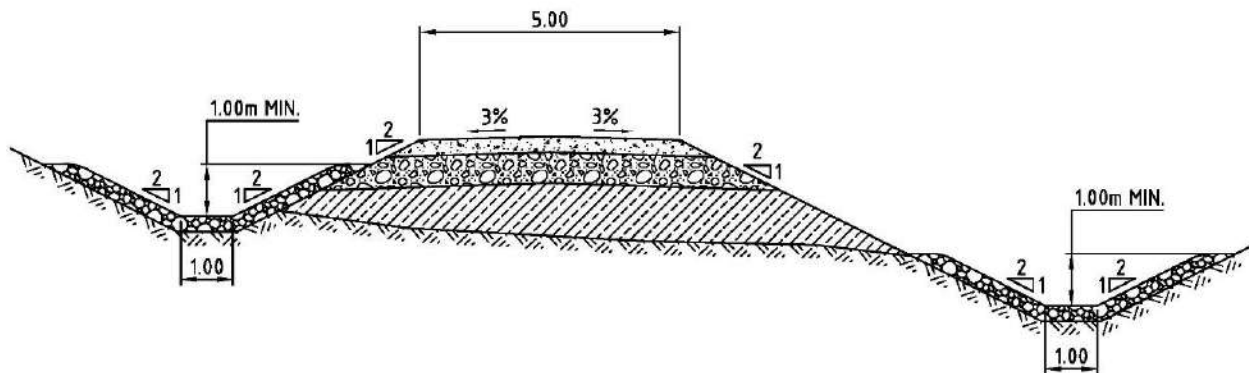

Figure 18-14: Service road – Typical cross-section

18.19.2 Haulage Roads

For mine trucks and tailings transport, three segments of 12-m wide haulage roads will be constructed. Normal vehicle will be allowed to use these roads with specific safety procedures.

1. From Main portal to Lynx portal with accesses to the crushing plant truck dump, the ore stockpile, and the waste stockpile.
2. From Tailings Filtration Plant to Tailings Storage Facility ("TSF").
3. From Tailings Filtration Plant to Fuel Farm pad.

The haulage roads ditches will be equipped with a geomembrane to collect contact water and contaminants generated by the mine material.

Water, tailings, and service pipelines will be installed along these ditches and covered by a berm.

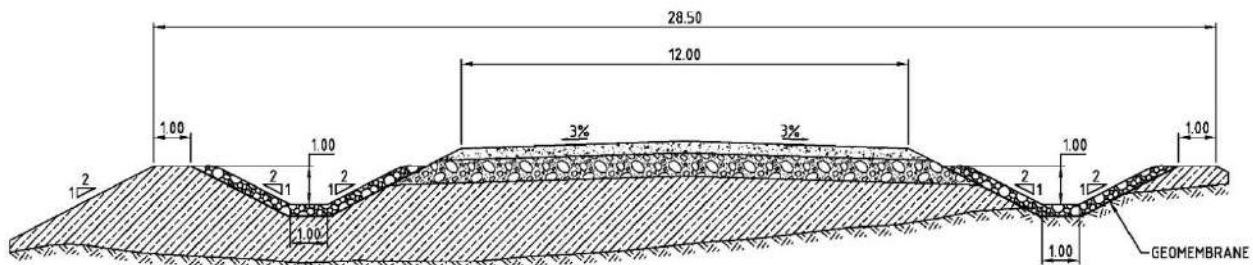

Figure 18-15: Haulage road – Typical cross-section

18.20 Electrical Infrastructure and Power Demand

Electricity will be supplied to the site at a voltage level of 13.8 kV from the Windfall substation constructed in the vicinity of Windfall mine site. From the substation, electrical power will be distributed to the underground mine, process plant, and other installations.

Most of the existing 13.8 kV overhead lines will be kept. The existing generator sets are planned to be reused for emergency power and backup during construction and operations.

18.20.1 Site Distribution

The process plant buildings, the underground mine, general surface infrastructure and the tailings filtration/paste plant will be fed at 13.8 kV through 15 kV cables or overhead lines from the Windfall substation.



A 13.8 kV switchgear (AIS type) will be installed in the main electrical room of the process plant at ground level to provide power to transformers to further step down the distribution voltage to useable 600 V voltage levels while other feeders will be dedicated for the SAG mill and Ball mills and crusher area through an overhead line.

The largest motors will be those of the SAG and ball mills, accounting for over 20% of the total site power demand. The mills will be controlled by variable frequency drives and will be configured to keep the harmonics generation within acceptable limits as per Hydro-Québec requirements.

18.20.2 Power Demand

The power demand of the overall Windfall Project is approximately 27.4 MW. The calculated power demand was derived based on equipment lists from all areas while considering standby equipment and applying representative efficiency and load factors. Table 18-7 shows the distribution of power by area/sector for the site.

Table 18-7: Power demand by area

Area Description	Power Demand (MW)
Underground Mine and Mine Surface Facilities	8.9
Site Infrastructure	2.8
Process Plant	11.7
Paste Backfill Plant & Tailings	3.3
Electrical Network Losses (2.5%)	0.7
Total	27.4

18.20.3 Emergency Power

Emergency diesel generator units (600 V) are planned for the purpose of supplying electricity to the critical mining and process equipment/installations when the main power is lost. The generators will be installed outdoors in a shelter near the process plant building as an emergency power source. Critical loads will be grouped into different categories where some will be started automatically (lighting and critical services) and others controlled manually.

The generator sets of the current diesel power plant will be used as the emergency generators.

The emergency load requirements will exceed the planned installed power generation. Therefore, sequenced starts of critical loads through a PLC based program will be necessary to ensure that the installed back up power capacity is sufficient for the emergency load requirements.



18.21 Telecom and Industrial IT Infrastructure

The telecommunication and industrial IT infrastructure part of this study is aligned with the design of a modern mine with all the services required for an Industry 4.0 style operation incorporating short-interval control, predictive maintenance, VOD, teleoperation, an Integrated Operations Centre ("IOC") and LTE network to support the operation and safety of employees.

Equipment, accessories, and installation services have been considered for the systems of the surface and underground mines as well as systems to support the efficient operations of the process plant and surface operations.

18.21.1 Integrated Operations Centre (IOC)

The Windfall mine, process plant and tailings filtration/backfill plants will be managed and operated from a centralized IOC located on site within the multi-services building. All areas of the site, including the process plant, underground operations, tailings management and water management will be integrated to the IOC.

Through its data-oriented philosophy, the IOC will aim to:

- Reduce the effort related to the ramp-up of employees in a context of workforce shortage;
- Ease the interoperability with business partners (contractors, suppliers, service providers) by enabling data sharing;
- Ensure transparency with stakeholders;
- Achieve operational targets in terms of downtime and utilization by leveraging real-time usage of data for fast deviation identification and correction.

Mine-to-mill integration will be implemented along with Integrated Planning and Scheduling to optimize the production value stream across the mine and process plant. (BBA, 2022)

18.22 Tailings Management Facility

The tailings management facility ("TMF") will include the dry tailings stack, its network of granular drains and the surrounding road. It should be noted that the terminology "dry stack" refers to the concept of the structure and is not related to the water content of the filtered tailings in the stack. The water management infrastructure ("WMI") surrounding the TMF to collect contact water and to deviate clean water when possible is described in Section 18.23. Water management is intrinsic to tailings management and has been considered to ensure an integrated design. Figure 18-16 shows the general arrangement of the TMF and related water management infrastructure.



18.22.1 Geotechnical Considerations

The geotechnical investigation conducted in 2022 (Golder, 2022a) indicated that the TMF was partly located in a wetland and allowed to define the geotechnical basis for its design (Golder, 2022b). The principal geotechnical considerations are:

- Presence of contractive layers within the granular deposit, based on a preliminary analysis of the standard penetration test ("SPT") data (Golder, 2023a);
- High water table generally located at the interface between the topsoil and the granular deposit (Golder, 2022a);
- Contractive layers non-susceptible to seismic liquefaction for the TMF operation design earthquake, based on a preliminary analysis of the SPT data (Golder, 2023a);
- Contractive layers susceptible to seismic liquefaction for the TMF closure design earthquake, based on a preliminary analysis of the SPT data (Golder, 2023a).

18.22.2 Tailings Management Facility Design and Strategy

Tailings will be stored in the TMF, which consist of a dry tailings stack, located less than 1 km northeast of the tailings filtration and paste backfill plant. The location of the TMF is shown in Figure 18-2. The tailings will be hauled by trucks from the tailings filtration and paste backfill plant and compacted in a controlled manner in the dry tailings stack.

The current Project planning indicates that 8.2 Mt of dry tailings (including around 5% of mixed in sludge from underground water decantation system) will be stored in the surface tailings facility. This tonnage considers that around 40% of the tailings will be returned underground as a paste backfill material. To provide a contingency, Osisko has chosen to design a tailings facility with a capacity of 9.0 Mt (including the mixed-in sludges).

Table 18-8 presents the main properties of the tailings based on the 2020-2021 geotechnical characterization (Golder, 2022c). Sludges coming from underground operations that will be mixed with tailings prior to their filtering were not included in the 2020-2021 tailings characterization. The sludge consists of very fine particles and its content in the mixture with the tailings is expected to be around 5%. For the Feasibility Study, it is assumed that the mix of tailings and sludge will form a homogeneous mixture and that the addition of sludge in the tailings will not have a significant impact on their geotechnical properties.



Table 18-8: Tailings production and main properties of the tailings

Description	Unit	Tailings
Total production tonnage	Mt	8.2
Solids content (w/w) percentage	%	81 to 84
Grain size at 80% passing	µm	37
Specific gravity	-	2.85 to 3.01
Maximum dry unit weight (standard proctor)	kN/m ³	16
Optimal geotechnical water content (standard proctor)	%	21.5

The proposed TMF has a maximum elevation of 423 m in the northwest sector and 420 m in the southeast sector, resulting in a 0.5% slope at the top of the stack that promotes water runoff from the TMF to the WMI. No water will be allowed to pond within the tailings facility. The final sides slopes of the dry tailings stack will be 4.5H:1V. Figure 18-16 shows a plan view of the TMF and Figure 18-17 a typical cross-section of the TMF.

The proposed TMF will be built on prepared foundation. The preparation includes organic soil stripping and the clearing and grubbing of the surface. Where necessary, the foundation of the TMF will be raised with granular material to ensure that the lower points in the southeast and northwest sector of the facility are at a minimum elevation of 400 m and 401 m respectively. The intent of this raise is to have the base of the TMF higher in elevation than the maximum design water levels of the ponds and contact water ditches. This raise will be constructed with a slope of 1% to promote water drainage outside of the TMF.

Geochemical characterization indicates that the tailings are potentially acid generating, leachable for metals and cyanide-bearing. The metallurgical processing includes a cyanide destruction step. Considering the potential for acid generating, metal leaching, the potential presence of residual traces of cyanide in the tailings pore water, and a relatively permeable foundation, the design of the TMF includes a geosynthetic liner as a mitigation measure to limit pore water seepage to groundwater. A liner system including linear low-density polyethylene ("LLDPE") liner with a thickness of 1.5 mm and an overlaying geotextile layer is proposed at this stage of the study. The liner system will be installed above the granular foundation raise where present. Except for the granular material used to raise the TMF, it is assumed that no extra measures (granular material and/or underlying geotextile) will be needed prior to the installation of the liner system.



A network of granular drains will be constructed on the liner system to facilitate water drainage and promote the desaturation of the tailings. The preliminary design of the drains network consists of 2-m high drains, including a granular transition layer to ensure material compatibility with the tailings. The drains will be positioned parallel to the natural drainage axes with a minimum spacing of 100 m (centre to centre) and a minimum slope of 1%. Another drain will be installed at the toe of the stack. A 2-m high service road, also made of granular draining material, will be constructed around the TMF for services and will serve as an extension of the toe drains.

The tailings will be placed mechanically directly on the geosynthetics system and compacted to 95% of Standard Proctor optimum dry density. Access roads will be periodically needed in the TMF during operations to facilitate the placement of tailings.

To ensure the stability of the southeastern area of the TMF, a berm is required in the Pond TMF#1.

The proposed TMF will be developed in three phases to facilitate operations and promote progressive reclamation as recommended per the MERN closure guidelines (MERN, 2022). Table 18-9 presents the capacity and the years of operation of the three phases. Phase 1 has the largest capacity and the largest area to have contingency space in the early years of operation.

Table 18-9: Tailings deposition plan

Phase	Capacity (dry tailings)	Years of operation
Phase 1	4.8 Mt	-1 to 5
Phase 2	2.5 Mt	6 to 8
Phase 3	1.7 Mt	9 to 11

The proposed TMF design satisfies the required stability criteria proposed in the Direction 019 on the mining industry (MDDEP, 2012) and is supported by slope stability analyses (Golder, 2023a). Stability analyses were completed based on the available geotechnical data. Additional geotechnical mitigation measures are required for closure and are included in the estimated closure costs.

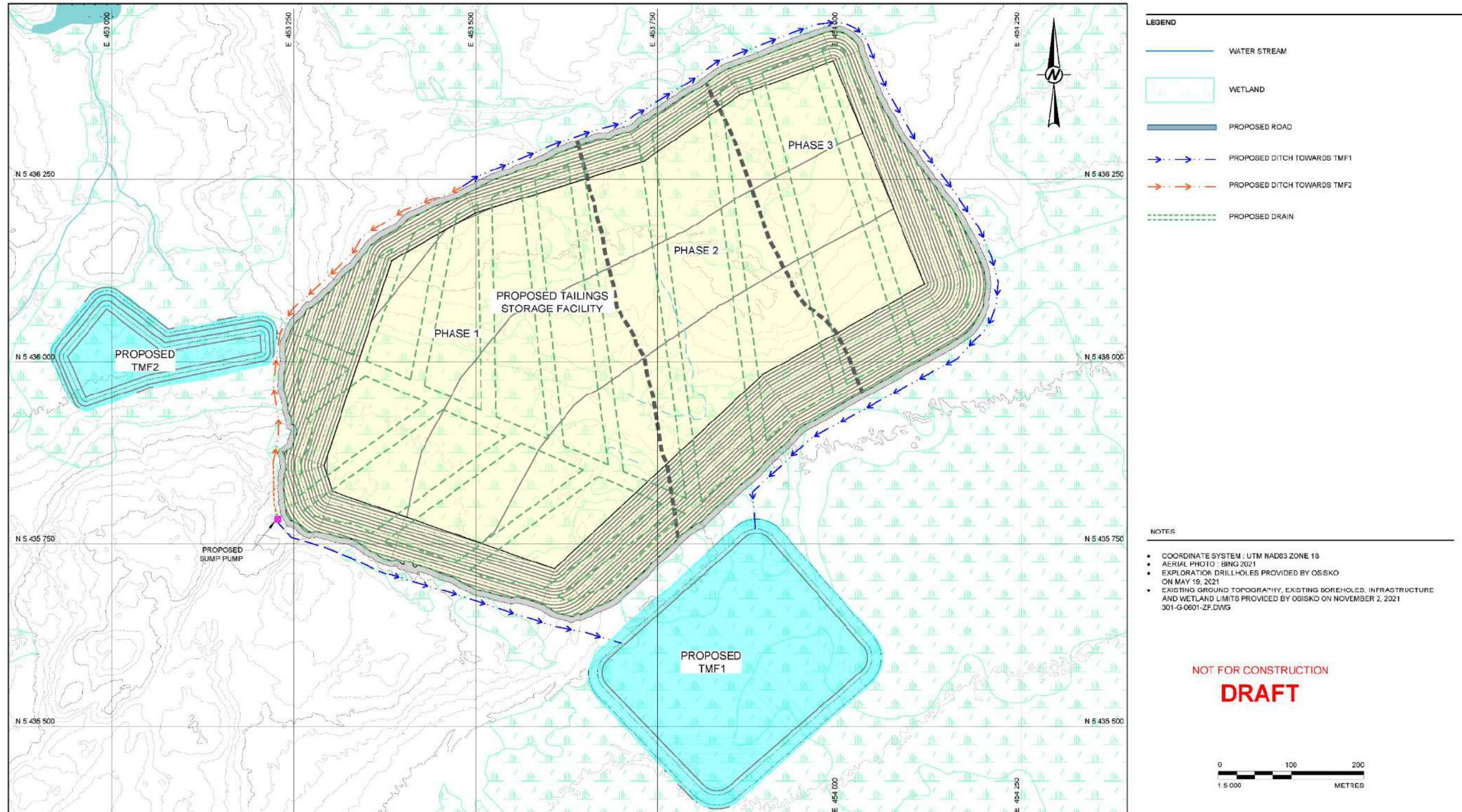

Figure 18-16: Plan view of the tailings management facility

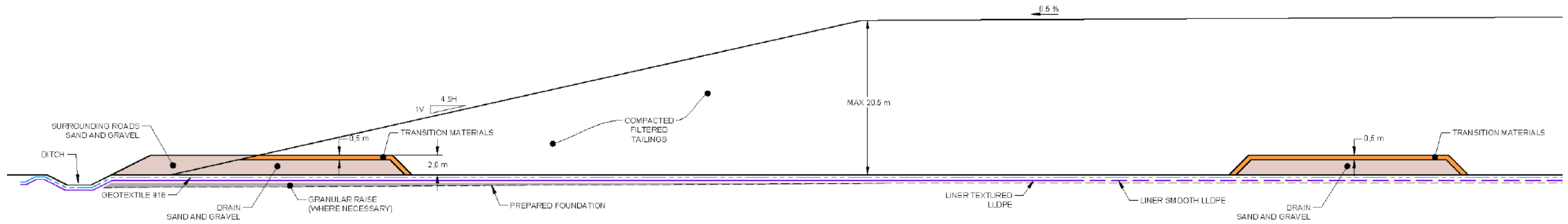

Figure 18-17: Typical cross-section of the tailings management facility



18.23 Water Management

The following water management infrastructure is considered as existing:

- The collection pond;
- Perimeter ditches around the existing waste rock stockpile ("WRS");
- Ponds A, D and P and ditches around the WRS;
- Water Treatment Plant;
- Bulk phase ammonia water treatment plant ("WTP").

Pond SP1 will no longer be used.

Water management infrastructure for the mine will include:

- Non-contact water diversion ditches;
- Contact water collection ditches;
- TMF ponds and other collection ponds;
- Pumping systems including sumps, pumps and pipeline;
- Polishing pond;
- Existing water management structures that will be integrated with the new system of ditches and ponds.

The layout of the water management structures is provided in Figure 18-18.

Non-contact water diversion ditches aim to collect and divert external catchments runoff around the TMF and runoff from small undisturbed areas throughout the mine site.

The site contact water includes the water that has been in contact with waste rock, the ore stockpile (ponds C/C2), as well as the industrial zone, which includes the run-of-mine pad, the crusher, the process plant and the roads (ponds C/C2, U). This water will be collected and directed to the accumulation pond (D/D2) by a system of perimeter ditches, transit basins and pumps, as shown in Figure 18-18.

Water from the overburden stockpile and industrial pad is collected in ditches, conveyed to sedimentation ponds (ponds B, J) and treated for TSS/Metals before being discharged into the environment.

Water collected in the TMF ponds will be pumped to the process plant for reuse or to the water treatment plant for treatment prior to its discharge in the environment. TMF contact water is separated from the rest of the contact water system and only mix in the treatment plant.



Tailing Ponds Design Considerations

The tailings ponds (TMF Pond #1 and TMF Pond #2) are designed with the following constraints:

- For Years 1-4, no pumping will be happening during the spring freshet due to treatment constraints. The two TMF ponds are designed to store the total runoff volume generated by the design event.
- For Years 5-11, pumping is assumed to start only 24 hours after the beginning of the design event.

In addition to TMF Ponds #1 and #2, one section of the western TMF perimeter ditch has been designed to act as a pond collecting contact water from a portion of the TMF and of the overburden pile. A pumping system located in the ditch will send the collected water to the TMF Pond #1. This ditch is designed for the same event as TMF ponds.

Ponds D/D2 Design Considerations

For Years 1-4, Pond D only has sufficient capacity to manage the design event.

At some point during Years 5-11, the development of site infrastructure (WRS, TMF) will require the addition of Pond D2, as an extension of Pond D to manage additional contact water.

Design Criteria

Table 18-10 and Table 18-11 summarize the hydrological and hydraulic design criteria for the site's water management infrastructure.

Table 18-10: Hydrological and hydraulic design criteria – Ponds

Parameter	Pond	Criterion	Source
Environmental Design Flood ("EDF")	TMF Pond#1, TMF Pond#2 and oversized west ditch	Rainfall of 24-hours, 2,000-years recurrence + Climate change + 100-years snow cover melt over 30 days	D019 (MELCC, 2012)
	Other ponds	More critical among: <ul style="list-style-type: none"> ■ Rainfall of 24-hours, 100-years recurrence + Climate change ■ Rain + snowmelt, 30-days, 100-years 	D019 (MELCC, 2012)
Freeboard (between the maximum water level during the design flood and the top of the embankment)	TMF Pond#1 and TMF Pond#2	1.5 m	D019 (MELCC, 2012)
	Ponds D/D2	1 m	Good practice
	Other ponds	0.5 m	Good practice



Parameter	Pond	Criterion	Source
Inflow Design Flood ("IDF") for Emergency spillway (if the basin has a dike)	All ponds	PMF (min 3 m width and 0.5 m depth)	D019 (MELCC, 2012) Good practice

Table 18-11: Hydrological and Hydraulic Design Criteria – Ditches

Parameter	Criterion	Source
Design flood	Rainfall of 24-hours, 100-years recurrence + Climate change	D019 (MELCC, 2012)
Minimum longitudinal slope	0.3 %	Construction constraints and good practice
Freeboard (Distance between the maximum water level during the design flood and the top of the bank)	Minimum 0,3 m ⁽¹⁾	Good practice
Riprap	According to the erosive power of the water flow (speed, water level)	MTQ / Guide to Bridge Hydraulics (ATC)

⁽¹⁾ For contact water ditches around the TMF, the freeboard must allow conveyance of the 2,000-year flood without overflow

18.23.1.2 Description of Water Management Infrastructure

Pond Sizing

The ponds and pumping capacity are listed in Table 18-12. The pump capacities have been chosen to take into account treatment capacity and soil conditions, while limiting as much as possible ponds footprint.

Each pond that has a dike is designed with an emergency spillway. These spillways have a depth of 0.5 m, except for the Ponds D, TMF Pond #1 and TMF #2 that have a depth of 1.0 m. The width of the weir is adapted for each of the basins to pass IDF (Table 18-10).



Table 18-12: Hydraulic design of the ponds

Pond Identification	Effective Capacity (m ³)	Pumping Rate (m ³ /h)	Max Depth (m)	Min Freeboard (m)
Pond A ^{(1),(3)}	9,650	90	5	0.5
Pond B	13,350	250	3	0.5
Pond C	7,600	65	2.5	0.5
Pond C2	9,750	-	2.5	0.5
Pond CP ^{(2),(3)}	6,950	Years 1-4 : 72 Years 5-11 : 97	1.5	0.4
Pond D ^{(1),(3)}	74,100	Years 1-4 : 293 Years 5-11 : 150	6	1.0
Pond D2	42,000	-	5.5	1.0
Pond F	21,800	Years 5-11: 10	4	0.5
Pond J	3,700	200	4.5	0.5
Pond P ^{(1),(3)}	8,500	1,000	2.5	0.5
Pond U	5,450	100	4.5	0.5
TMF Pond#1	204,600	200		1.5
TMF Pond#2	34,200	30	4.5	1.5

- ⁽¹⁾ These ponds were designed for the bulk sample stage of the Project.
- ⁽²⁾ The collection pond ("CP") is an existing pond.
- ⁽³⁾ The pumping rates could have been modified from previous stage of the Project to adapt for the final layout of the Mine Site.

Ditch Sizing

The typical base width of the ditches vary between 1.0 m and 1.8 m, except for the storage ditches located around the TMF.





18.23.2 Water Management Infrastructure Geotechnical Design

18.23.2.1 Contact Water Storage Ponds

Ponds B, C1, C2, F, D2, J and U will be built as a cut and fill operation with predominant excavation. A small embankment will be added to provide required storage capacity and adequate freeboard. Organic material will be stripped and stored in the overburden stockpile. The embankment foundation will be adequately prepared and the mass backfill will consist of native sand from the excavations.

The embankment height has been defined to reach a sufficient storage capacity while limiting the footprint of the ponds, limiting the height of the perimeter embankments and respecting minimal elevation for drainage of collecting ditches. Where bedrock is shallow, drill and blast will be used.

All contact water ponds will be lined with textured geomembrane to ensure no contact water is released into the environment. The liner is placed on an imported draining material and armoured with selected waste rock to prevent damaging the liner during periodical maintenance (sediment or ice removal).

The embankments of the ponds have a 3:1 upstream slope and 2.5:1 downstream slope to respect the suggested factors of safety in the Directive 019 guideline. A rock toe will also be built as a protection against piping, when estimated required. Depending on their height, the embankment crest will be 5 m or 8 m wide. Where a drop-off of more than 3 m is possible, bumpers have been integrated into the design.

The ditches conveying contact water and perimeter ditches of the contact water ponds will also be lined.

Ditches conveying the contact water from the overburden stockpile or treated water, as well as Ponds J and U, are also lined but armoured with imported material, geochemically stable.

18.23.2.2 TMF Ponds

The main collection pond will be located south of the TMF (Pond TSF#1); the second pond will be located northwest of the TMF (Pond TSF#2).

The ponds will be built as a cut and fill operation with predominant excavation, with the addition of small embankments to provide required storage capacity. Organic material will be stripped and stored in the overburden stockpile for mine closure purposes. The embankments foundation will be adequately prepared, and the mass backfill will consist of native sand from excavations. A



liner will be placed in the bottom of the ponds and will be protected adequately and armoured with waste rock. The proposed design takes into account the geotechnical data collected in 2021 and 2022 and provides the recommended safety factors according to the Directive 019 guidelines.

Each pond will have an emergency spillway to pass floods generated by storm events beyond the environmental flood storage event, and up to the Probable Maximum Precipitation ("PMP").

18.23.3 Water Treatment

Water treatment will be required on the Windfall project site to:

- Meet the Mining Effluent Discharge Criteria Form Provincial Directive 019 (MDDELCC, 2012) and the Metal and Diamond Mining Effluent Regulations ("MDMER") (Ministre de la justice du Canada, 2022) from Environment and Climate Change Canada;
- Aim, within economical and technical limits, to meet potential environmental discharge objectives ("EDO") which have not yet been defined for the project.

The water treatment system will be located southeast of the process plant, beside the filtration plant. Most of the water treatment equipment will be installed in the existing warehouse annexed to the bulk sample ammonia WTP.

A simplified water treatment process diagram is presented in Figure 18-19, showing the four water treatment process lines. Details on design basis and assumptions are presented in the Water Treatment Plant Feasibility Technical Memorandum (GCM, 2022).

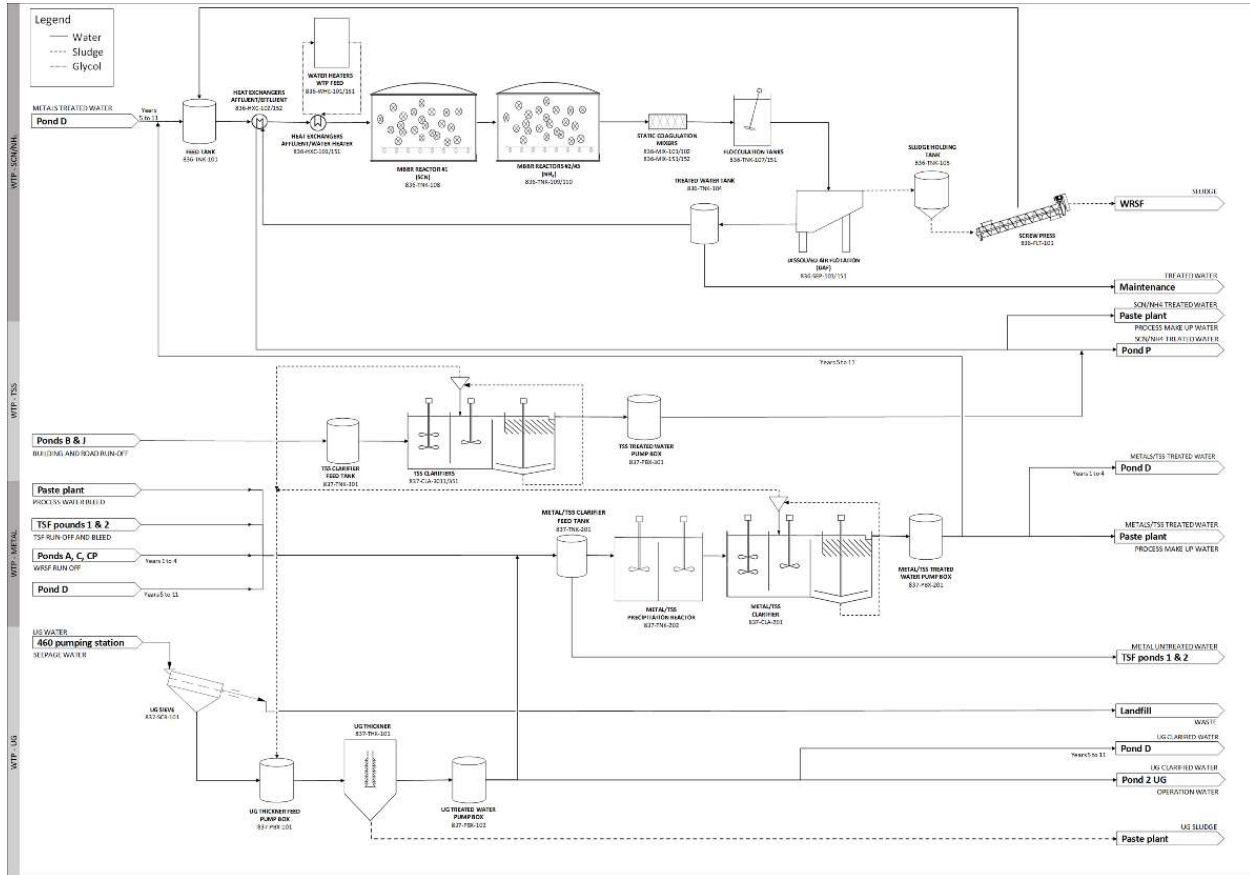

Figure 18-19: Simplified water treatment process diagram

The total suspended solids (“TSS”) WTP is dedicated to removing runoff sediments from overburdened stockpiles, roads, and building pads. Two parallel ballasted flocculation lamellar clarifiers (a small and a big unit) are required to manage high flow rate variations throughout the year and project flood event flow rate. The design considers a maximum TSS concentration of 100 mg/L (GCM, 2022).

The underground water (“UG”) WTP will be put in place to remove sediments from the mine water pumped to the surface as its solid contents will be between 2% and 6%. Water will first go through a screening step to remove any material that is larger than 3 mm to prevent any breakage of the filter cloth, as its solids will later be sent to the filtration plant. Water will then be processed into a high-efficiency thickener. Solids reporting to the underflow will be sent to the filtration plant to be co-deposited with tailings. The thickener water overflow will be used primarily to feed the underground operations and the excess will be further treated for metals and ammonia prior to being discharged into the environment (GCM, 2022).



The metals WTP is designed to remove mainly aluminum, arsenic, copper, iron, and lead contained in runoff water from the WRS, the TMF and the mineralized material stockpile (“MMS”) because of leaching processes. The metals WTP will also be able to treat metals from the underground water pumped to the surface and process water bleed required to maintain adequate water quality at the mineral processing plant. The treatment process allows for metals to be first complexed with sulphides in a reactor after which metal sulphides are precipitated into a ballasted flocculation lamellar clarifier (GCM, 2022).

The biological WTP will treat water coming from the metals WTP in a two-step process using a moving bed biofilm reactor (“MBBR”). In the first step, thiocyanates and cyanates—originally contained in process water and generated by cyanidation of sulphur containing mineral—will be oxidized into ammonia, bicarbonates, and sulfates. In the second step, the ammonia produced by the first treatment step and the ammonia originally contained in all water streams fed to the metals WTP will be converted into nitrates (nitrification). Water heaters and a heat recovery loop will be used to maintain optimal water temperature for treatment. Generated biomass will be removed by dissolved air flotation (“DAF”) units and thickened in a screw press prior to disposal. The biological WTP described above will be put in place, upgrading the treatment plant that is considered existing for the Project. When putting in place the biological WTP, one of the two ammonia MBBR tanks will be converted into a thiocyanate oxidation reactor and an additional reactor will be added to reach the required effluent target. A water heater, two heat exchangers, a flocculation tank, and a DAF are some of the other equipment that will need to be added (GCM, 2022).

18.24 Waste Rock Stockpile (WRS)

18.24.1 Design and General Considerations

The waste rock volumes to be stored have been calculated from the tonnage estimated in the LOM document, plus a contingency determined by Osisko. The WRS will be lined because a portion of the waste rock is expected to be acid generating and metal leaching. The WRS design capacity is 9.11 Mt (4.46 Mm³). The volume of waste rock that will be used for construction purposes and that will need to be returned to the stockpiles during closure has been considered to ensure the WRS maximal capacity is not reached. The location of the WRS is shown in Figure 18-2.

The WRS, which has been in use since the acquisition of the Windfall site by Osisko, was first expanded in 2018 and again in 2020. The maximum capacity was reached in 2022. Therefore, a third extension, located to the west, is planned in 2023. This extension will bring an additional capacity of 1.68 Mt (0.81 mm³), for a cumulative total of 3.08 Mt of waste rock. The capacity of this extension is expected to be reached in 2026.



An additional bench of 15 m to 18 m will thus be added to the WRS. This bench will bring an additional capacity of 2.3 Mt, for a cumulative total of 5.38 Mt of waste rock. The capacity of this extension is expected to be reached in 2030.

Finally, a last expansion will add 3.73 Mt for a total of 9.11 Mt of waste rock stored. The final extension of the WRS will go southward and cover the existing overburden stockpile that will be relocated.

The location and design of the WRS is intended to reduce the impact on the environment by limiting the mine site footprint, the hauling distances required to build the stockpile and the expansion of the existing waste rock stockpile.

18.24.2 General Design

The proposed design for the extension of the WRS is based on the following geometry:

- Total height of 32 m;
- Bench slopes of 3H:1V;
- Average bench height of 16 m, for a total of two benches;
- Average final slope 3.4:1;
- Berm width of 10 m between each bench.

The proposed design follows the Design for Closure Concept as low-profile stockpiles reduce the rework required during closure and allow for a better integration into the surrounding landscape.

Required works for the construction of the WRS include topsoil removal, foundation preparation and the installation of a HDPE liner. The liner will be installed over the whole footprint of the WRS. The liner will be reinforced with two layers of geotextile (one below and one above the liner). A layer of 0-56 mm granular material will be placed on top of the geosynthetics for protection against heavy machinery traffic, thus preventing puncture during the operation. The membrane will extend into perimeter ditches that will collect any contact water.

The two previous WRS extensions (2018 and 2020) were built following the same construction sequence and have proven to be effective.

18.24.3 Geotechnical Considerations

The geotechnical investigations conducted in 2021 and 2022 confirm the proposed design assumptions and allowed for stability analyses to be carried out according to the stockpile design proposed in this Feasibility Study.



18.25 Ore, Topsoil and Overburden Stockpiles

18.25.1 Ore Stockpile

An ore stockpile with a capacity of 157,750 t (54,553 m³) is planned to be located next to the crushing plant, as shown in Figure 18-2.

The stockpile is designed to have a maximum height of 10 m, one bench and 3H:1V slopes. The stockpile that will be used as temporary storage before being transferred to the crusher will rest on an elevated pad to facilitate the transfer of ore to the crusher.

As the ore is classified as PAG and possibly leachable for metals, this stockpile footprint will be lined with a geomembrane and protective layers of geotextile. A perimeter drainage ditch that encircles the crusher pad is designed to collect the runoff water. Other construction works required are topsoil removal, overburden excavation, landscaping and backfill of a layer of granular material to ensure the protection of the geosynthetic liners.

18.25.2 Topsoil and Organic Material Stockpile

The topsoil to be stored and managed at the Windfall site comes mainly from the site preparation required for the construction of the TMF, the process plant, as well as the stockpiles and ponds. The required storage capacity was estimated using the area of the proposed infrastructure and the topsoil thickness estimated from the boreholes. It is expected that topsoil thickness varies between 0.15 m and 2.3 m. The overburden will mainly include organic material such as peat and topsoil.

The identified site for the overburden stockpile can accommodate 638 100 m³.

The proposed design for the overburdened stockpile is based on the following geometry:

- Total maximum height of 21 m;
- Bench slopes of 4H:1V for the two lower benches and 3H:1V for the last bench;
- Bench height of 7 m, for a maximum of three benches;
- Average final slope 4.6:1;
- Berm width of 10 m between each bench.

The overburden stockpile will not be lined with a geomembrane, but runoff water will be collected by perimeter ditches and directed to Pond J before it is treated and released to the environment.



18.25.3 Overburden Storage

Overburden retrieved from basins and ditches excavation will be selected at the construction site and reused as backfill, either on the same construction site, or at another work site. Overburden materials unproper for earth backfill of embankments or access roads will be sent to the topsoil and overburden stockpile. A conservative amount of topsoil has been considered to cover the amount of overburden sent to the topsoil stockpile.



19. Market Studies and Contracts

19.1. Introduction

The Windfall Project will produce gold and silver in the form of doré bars. The market for doré is well established and accessible by all new producers. Doré bars produced from the Windfall Project will be refined in a certified North American refinery. The gold and silver will be sold on the spot market.

19.2. Market Studies

Gold and silver are freely traded precious metal commodities on the world market, for which there is a steady demand from numerous buyers. The markets for gold and silver are global in nature and is unlikely to be affected by production from the Project.

Due to their widely traded nature, it is not difficult to determine the market value of gold or silver at any particular time. Gold and silver are typically sold through commercial banks and metal traders with sales price obtained from the World Spot or London fixes. These contracts are easily transacted and standard terms apply. BBA expects that the terms of any sales contracts would be typical of, and consistent with, standard industry practices and would be similar to contracts for the supply of doré elsewhere in the world. Limited additional effort is expected to be required to develop the doré marketing strategy.

19.3. Exchange Rate and Precious Metal Price Projections

This Feasibility Study assumes a long-term CAD/USD exchange rate of 1.30:1.00, a gold price of USD1,600/oz and a silver price of USD21.00/oz to support the base case economic analysis as summarized in Chapter 22. The CAD/USD exchange rate and metal prices were established by Osisko based on consensus estimates derived from bank analysts' long-term forecasts (November 2022), historical metal price averages and prices used in recent publicly disclosed comparable studies that were deemed to be credible. Figure 19-1 and Figure 19-2 show the historical average monthly prices for gold and silver respectively since October 2019.

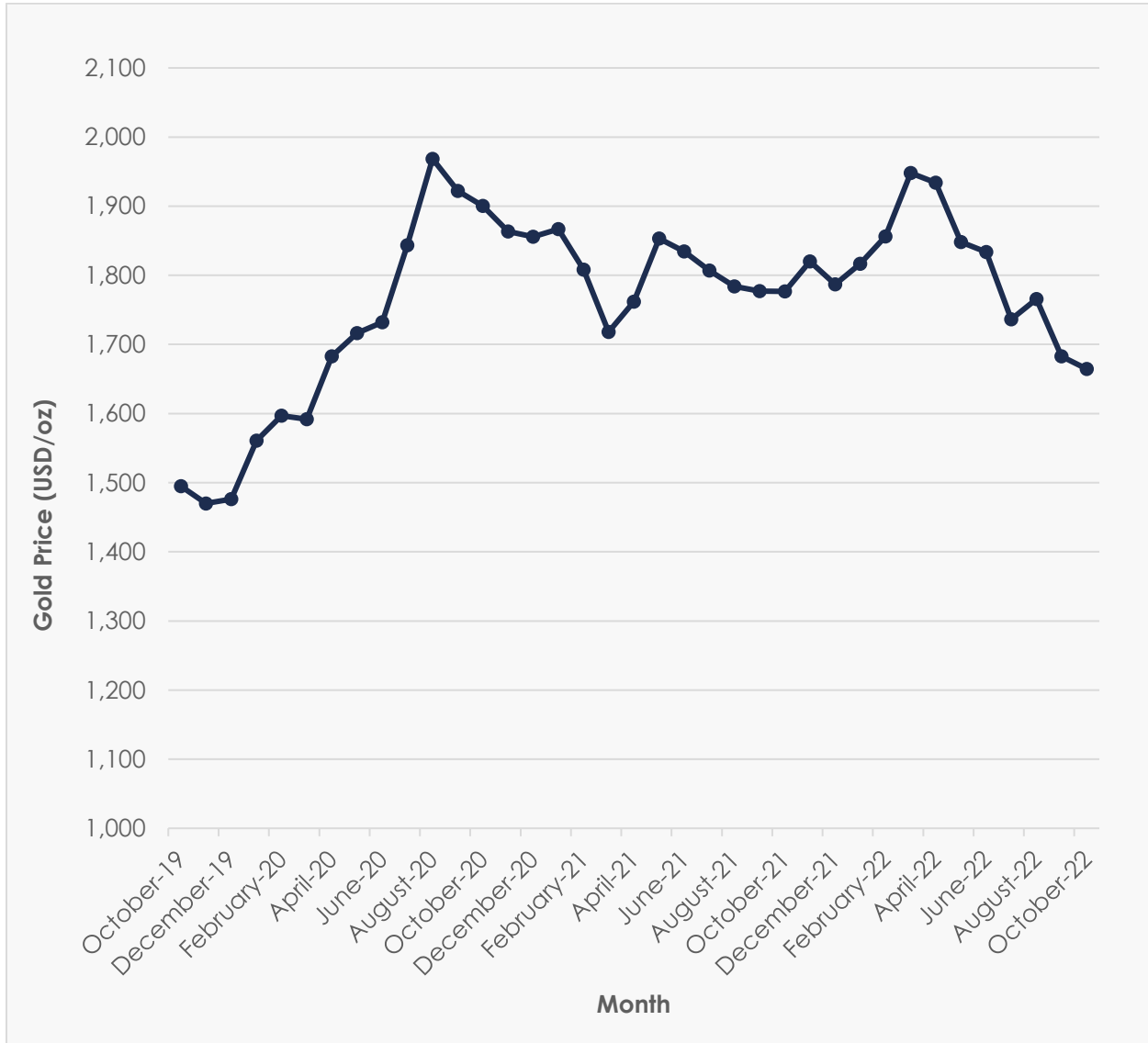

Figure 19-1: Historical average monthly gold price (USD/oz)

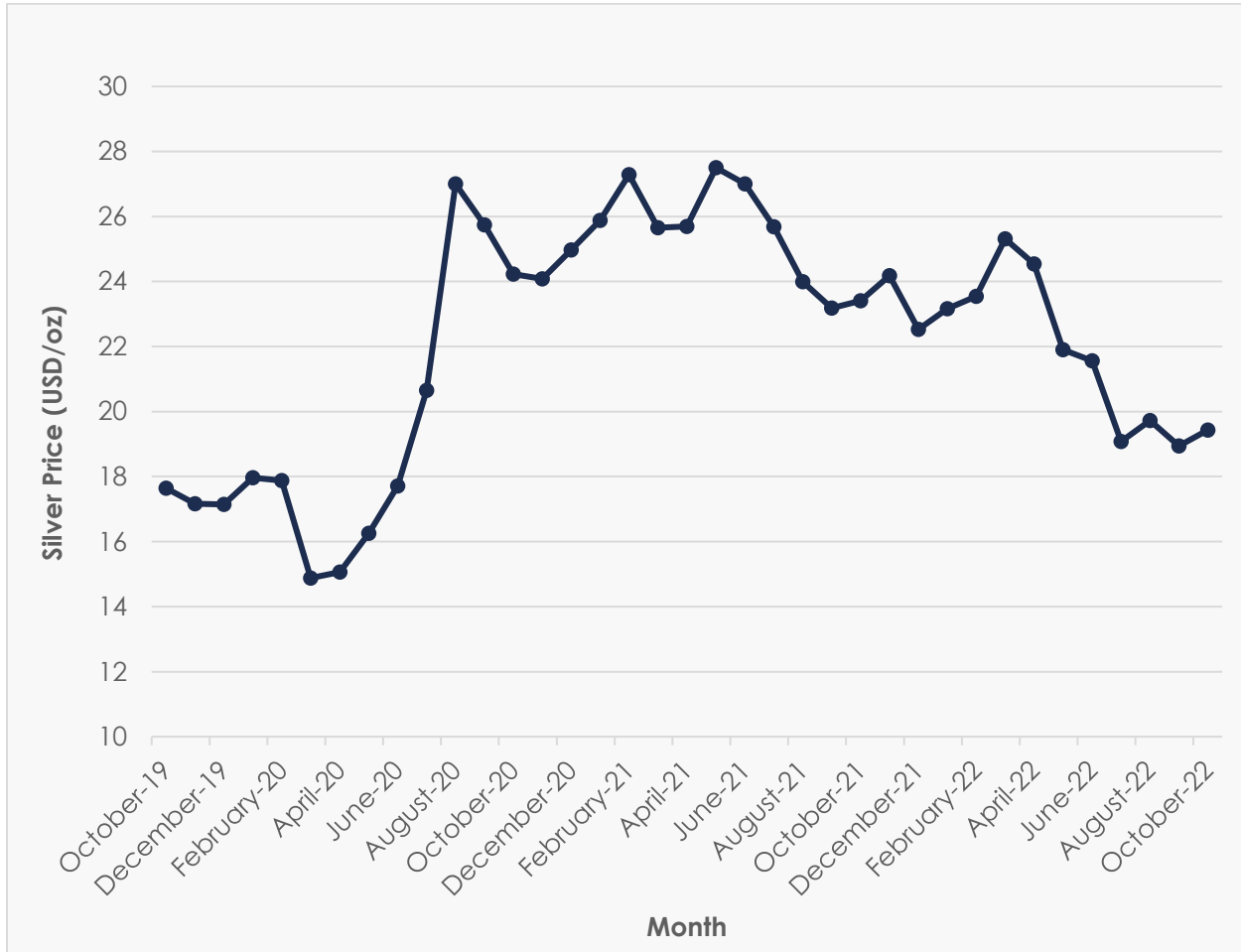

Figure 19-2: Historical average monthly silver price (USD/oz)

The forecasted exchange rate and precious metal prices are kept constant and are meant to reflect long term expectations over the life of the Project. It should be noted that exchange rate and precious metal prices can be volatile and that there is the potential for deviation from the LOM forecasts.



19.4. Contracts

There are no refining agreements or sales contracts currently in place for the Project that are relevant to this Technical Report. BBA expects that terms contained within any sales contract that could be entered into would be typical of and consistent with standard industry practices, and be similar to contracts for the supply of gold and silver elsewhere in the world.

There are several large LBMA accredited third-party precious metal refineries with well-established industry relationships in North America. Among the more notable ones are:

- Canadian Mint; Ottawa, Ontario, Canada;
- Asahi (Johnson Matthey); Brampton, Ontario Canada;
- Metalor Technologies USA; North Attleboro, Massachusetts, USA;
- Asahi (Johnson Matthey); Salt Lake City, Utah, USA;

None of the aforementioned refineries have been contacted to provide a competitive treatment bid.

This Feasibility Study assumes a refining, transportation and insurance charge of USD5.00/oz of gold and payable terms of 99.95% for gold content and 99.5% for silver content.

19.5. QP Note

Colin Hardie, QP, notes that Osisko's gold and silver pricing as well as the CAD/USD exchange rate, used in the cashflow analysis, are aligned with BBA's internal guidelines and recent surveys of industry-consensus prices available in the public domain.



20. Environmental Studies, Permitting, and Social or Community Impact

This chapter summarizes the existing environmental and social conditions within the Project area based on data available at this stage of the Project. It also provides the environmental requirements for ore, waste rock and tailings disposal, site monitoring, and water management. The regulatory context applicable to the Project, including the environmental impact assessment (“EIA”) process and preliminary permitting requirements, is then overviewed, as well as the social and community requirements. The consultation activities conducted so far and the main concerns raised by the different stakeholders consulted are also listed. Finally, it outlines the mine closure requirements and costs.

20.1. Environmental Baseline Studies

During the period spanning 2007-2015, several environmental studies, analyses, and reports have been completed for the Project. After Osisko acquired the Project, additional baseline studies were carried out between 2015 and 2022 to obtain updated data and an accurate picture of existing conditions within the Project area.

The following environmental components were studied in multiple field campaigns:

- Aquatic fauna (fish and benthos);
- Wildlife (avifauna, mammals, herpetofauna and chiropterans);
- Geochemistry;
- Hydrology;
- Hydrogeology and groundwater quality;
- Noise;
- Surface water and sediments;
- Vegetation and wetlands;
- Soil natural background assessment;
- Hydrogeological modelling;
- Water quality modelling;
- Climate change resilience.

Finally, the following ongoing environmental verifications are required to comply with the EIA requirements:

- Atmospheric dispersion modelling;
- Greenhouse gas emissions assessment;
- Noise and vibration modelling.



20.1.1. General Description

The Windfall Project is located north of the 49th parallel, in the Northern Québec administrative region (Region 10), on Category III lands of the Eeyou Istchee James Bay Territory. The Project site is located about 270 km from Val-d'Or, and 115 km east of Lebel-sur-Quévillon, an area known for its gold, copper and zinc deposits.

In 2022, the Windfall property consisted of 286 individual claims, spread over an area of 12,523 ha (Figure 20-1).

Two categories of study areas have been identified for the EIA:

1. The "regional study area" is an extended area where some social and potential cumulative effects have to be considered. This regional study area, which includes the Cree community of Waswanipi and the towns of Lebel-sur-Quévillon, Chapais and Chibougamau, is used, mainly, for the description and impact assessment of the socio-economic components.
2. The "local study area" covers a limited area, likely to be directly impacted, between 25 km² and 80 km² around the Windfall Project site. Two local study areas have been identified, one for the biophysical components and one for the social components. In addition, inventory zones of various sizes were used within these local study areas as presented in the sectoral reports of the specific biophysical components.

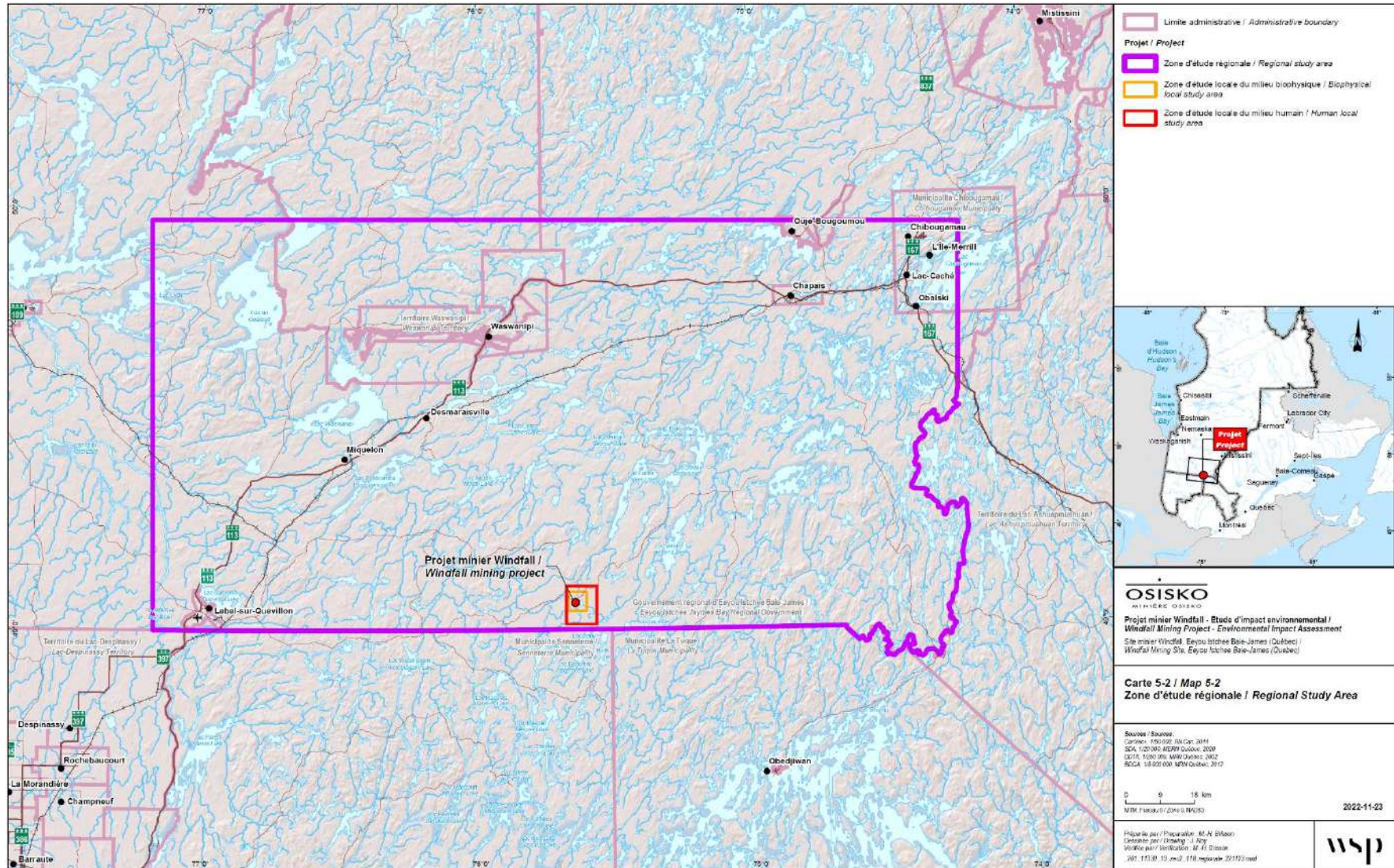

Figure 20-1: Environmental and social study areas



20.1.2. Baseline Conditions

The following subsections summarize the Project's current biophysical environmental conditions. Unless mentioned otherwise, the information comes from WSP's studies.

20.1.2.1. Biological Components

Aquatic Fauna

Field campaigns were conducted in the summers of 2010, 2015, 2016, 2017, 2018, 2021 and 2022 to characterize fish communities in nine lakes, 33 watercourses and two ponds. Except for Kettle Lake, fish were caught in all lakes and ponds inventoried. Of the 33 study streams, 21 of them provide fish habitat throughout their characterized portions. Twelve species were captured: mottled sculpin, lake chub, white sucker, cisco, lake whitefish, northern pike, yellow perch, burbot, walleye, fallfish, brook trout and brook stickleback. All watercourses having a direct link with a waterbody and where fish presence was confirmed should be considered as fish habitat, unless obstacles to free movement of fish have been documented. Information from workers and members of the Waswanipi community regarding fish was gathered along the EIA process and used to complete field data. No special status species were recorded.

According to available data, the mine waste disposal facilities (tailings and waste rock) and their related water ponds are not located on fish habitat.

Wildlife

Avifauna

Inventories of avian fauna were carried out in 2016, 2017 and 2021. A total of 79 bird species (28 families) were observed. Of this number, nesting was confirmed for 17 species, was judged probable for 19, and possible for 41. Two additional species were observed, but no nesting status was given. By combining the observations from the inventories and the public database, the list of species using the study area or its surroundings during the spring migration, nesting, fall and winter migration periods, could be up to 86 species.

Along with the bald eagle (*Haliaeetus leucocephalus*), a total of five special status bird species were observed within the Windfall Project area: the common nighthawk (*Chordeiles minor*), the rusty blackbird (*Euphagus carolinus*), the olive-sided flycatcher (*Contopus cooperi*), and the Canada warbler (*Cardellina canadensis*).



Micromammals

Inventories carried out in 2016, 2017, and 2021 confirmed the presence of seven species of micromammals, in addition to jumping mice and shrews that could not be identified to the species. No special status species were found, and no mentions are recorded in the government databases in a 15 km radius from the Windfall Project site.

Chiropterans

Inventories on chiropterans were carried out in 2016, 2017, and 2021. The presence of six species was confirmed: hoary bat (*Lasiurus cinereus*), northern long-eared bat (*Myotis septentrionalis*), eastern red bat (*Lasiurus borealis*), big brown bat (*Eptesicus fuscus*), little brown bat (*Myotis lucifugus*), and silver-haired bat (*Lasionycteris noctivagans*).

Both the northern long-eared bat and the little brown bat are on the federal endangered species list of the Species at Risk Act, whereas the hoary bat, red bat and silver-haired bat are listed on the provincial list of wildlife species, which are likely to be designated as threatened or vulnerable. No hibernacle nor maternity were confirmed within the Project's area during the 2016, 2017, and 2021 inventories. However, a few potential maternity sites have been identified during the 2021 inventory. No activity was observed at these potential maternity sites during the inventory; however, there remains a possibility that they could be used for whelping.

Other Mammals

The only specific inventories that were done to document terrestrial wildlife were for the woodland caribou and the moose. However, the presence of seven species was confirmed during the field work conducted in 2016 and 2017. Information from workers and members of the Waswanipi community regarding wildlife was gathered along the EIA process and used to complete field data.

The woodland caribou (or Boreal caribou) is a federal and provincial special status species whose presence has been documented in Northern Québec. The closest population, designated as the Assinica herd, which occupies the territory northeast of Lebel-sur-Quévillon, is the most likely to frequent the Project study area. The inventory carried out in March 2018 found only three caribou in the southern limit of the study area, nearly 20 km from the Windfall Project site. Observations from the 2018 inventory, combined with current knowledge, indicate that woodland caribou have made very little use of the study area over the past decade within a radius of approximately 50 km from the Windfall Project site.

The Windfall Project site is located 80 km south of the application area for the Woodland Caribou Habitat Stewardship Plan. Furthermore, the Project's influence area (50 km radius) does not overlap with critical habitat defined in the Recovery Strategy for the Woodland Caribou in Canada.



Herpetofauna

Inventories on herpetofauna were carried out in 2016, 2017, and 2021. Opportunistic observations were also noted during various field campaigns conducted in 2016 and 2017. The presence of eight species was observed. Based on the literature, nine other herpetofauna species could potentially be found within the study area.

No special status species were found, and no mentions are recorded in the government databases in a 10 km radius from the site.

Apprehended Impacts

Based on the studies conducted, most of the Project's impacts on wildlife are expected to result from habitat loss. To minimize the impact of the Project on wildlife, some standard and specific mitigation measures will be implemented by Osisko.

Vegetation and Wetlands

A total of 88 characterization plots or validation points were surveyed in 2016 and 2017 to describe the vegetation and wetlands within an extended inventory area. Additional field work of 233 characterization plots or validation points was conducted in 2021 to characterize the vegetation and wetlands within a limited inventory area at the Project site.

Across the 2016-2017 extended inventory area totalling 3,502 ha, 60.6% (2,121ha) is occupied by terrestrial vegetation, while 37.3% (1,306ha) is wetlands and waterbodies.

As for the 2021 limited inventory area totalling 699 ha, 47.5% (3,32 ha) is occupied by terrestrial vegetation, while 35.6% (249 ha) is wetlands and waterbodies. The rest is anthropic lands.

Terrestrial vegetation is mainly represented by regenerating forest groups dominated by black spruce and jack pine, sometimes in association with white birch. Wetlands are dominated by both ombrotrophic and minerotrophic peatland.

No special status or invasive species have been reported.

Thirty-six (36) plants of potential interest by the Cree for traditional purposes were noted on the field. Those are common and abundant species within the Project area and the region.

The proposed layout will directly affect wetlands. The Regulation respecting compensation for adverse effects on wetlands and bodies of water applies to the entire territory of Québec situated south of the 49th parallel, except for that part of the territory covered by section 133 (James Bay territory region located south of the 55th parallel) of the *Environmental Quality Act* ("EQA"). Also, the Project is not located on territories listed in Schedule I of the regulation. Therefore, no financial



contribution will have to be paid. However, the *Ministère de l'Environnement, de la Lutte contre les changements climatiques, de la Faune et des Parcs* ("MELCCFP") might ask, during the EIA process for a compensation program to reclaim or create wetlands or bodies of water.

20.1.2.2. Physical Components

Hydrology

The Windfall Project lies at the limit of three watersheds, the CE06B, CE02 and SN2 watersheds. The CE06B watershed flows into Matagami Lake via the Waswanipi River. The CE02 and SN2 watersheds also flows into Matagami Lake, but via the Bell River.

Seven field surveys, two in 2015, two in 2016, two in 2021, and one in 2022, were conducted to characterize watercourses likely to be affected by the Project. The three main targeted watercourses, CE06B, CE02 and SN2-E1, belong to the three different watersheds listed above. A bathymetric survey was done in 2017 on SN2 Lake to characterize that water body.

The specific average annual flow of the three watercourses has been estimated at 33.1 L/s/km². The annual low flow rate of Q_{10.7} has been estimated between 0.8 and 5.2 L/s/km², while the annual low flow rate of Q_{2.7} has been estimated between 1.7 and 6.5 L/s/km². The high-flow rate for a 2-year return period varies from 2.2 to 3.7 L/s/ha. Those low values are mainly explained by the relatively flat watersheds containing a high-proportion of waterbodies and wetlands.

Hydrogeology

This section describes the hydrogeological context at the Windfall Mine Site as presented in Section 16.3.

The hydrogeological conditions in the vicinity of the Windfall Project site were defined based on the field work conducted in 2017, 2020, and 2021 and past hydrogeological study (Genivar, 2008; Golder, 2018; Golder, 2020a). The results of these investigations are summarized in Golder (2022a).

Four main hydrostratigraphic units were identified:

- Surface deposits consisting of fluvio-glacial sediments (sand and gravel);
- Glacial till;
- Roc (felsic to mafic rocks intruded by granitoids and subvertical dikes);
- Faults.

The thickness of surface deposits varies between 1 m to 15 m within the Project area. However, it can reach 45 m in specific areas, on the eastern side of SN1 Lake and the western side of SN2 Lake.



Measured groundwater levels were overall close to the ground surface with depth ranging from 0 m (surface) to 13.5 m with a mean value of 2.2 m. The depth of the groundwater increases to the northwest. Topography generally controls groundwater flow directions.

Predictive simulations have been completed to assess water seepage into the underground mine. The model predicts that water inflows to the mine should be between 3,860 m³ and 4,570 m³ per day, at the end of the operational phase.

Based on dewatering simulations, the planned 1 m drawdown cone does not reach lakes located on the periphery of the mine. Drawdowns greater than 1 m (seasonal fluctuations) do not reach wells located at the existing exploration camp nor the possible water intake point for the mining operations camp.

Baseline Groundwater Quality

Groundwater quality data is available since 2007 and a biannual groundwater quality program is in place since 2017. These wells are located in the vicinity of the existing infrastructure. The results of the groundwater sampling program for 2020 and 2021 were compared to the MELCCFP groundwater resurgence ("RES") criteria and to the Canadian Drinking Water Quality criteria ("EC") (Beaulieu, 2021). The criteria comparison was made for the 2020 and 2021 results, as they are the most recent data and considered the most representative of actual groundwater quality conditions.

Twenty-one (21) wells (from the rock aquifer and the sand deposits) were sampled in 2020 and 2021. The groundwater samples were analyzed for dissolved metals, anions, cations, cyanides and nitrogen compounds, petroleum hydrocarbons C₁₀-C₅₀ and radionuclides (2020). The physicochemical parameters including pH, electrical conductivity, oxidation-reduction potential and temperature were also measured *in situ* during the sampling program. A similar analytical program was used for groundwater samples collected on previous years.

For the 2020-2021 campaigns, EC criteria exceedances were observed for ammoniacal nitrogen (52 % of the wells sampled), nitrite and nitrate (30 %), manganese (67 %), arsenic (10 %), aluminum (15 %), sulphide as H₂S, sulphide as S₂ (30 %) and nickel (one well). RES criteria exceedances were observed for ammoniacal nitrogen (1 well), nitrite (24 %), phosphorus (one well), sulphide as H₂S, sulphide as S₂ (19 %), copper (two wells) and zinc (one well).



Noise

Ambient noise level baseline was carried out in July 2017 at nine sensitive areas (residences, cottages, etc.) along the access road from Lebel-sur-Quévillon to the Windfall Project site, as well as within the Windfall Project site itself, in order to determine the ambient noise before the mining activities, and to determine the noise criteria for each sensitive area according to land uses and applicable regulations. Noise criteria depend on the Project phase (construction vs mining activities) and on the station location (sensitive zone vs non sensitive zone).

Another ambient noise level study was carried out in 2021 following the modification of the Project, which entailed an increase in activities at the Project site. Because of the highest noise levels expected, the ambient noise level baseline had to be reassessed for some sensitive areas near the Project site. Continuous noise measurements were recorded over a 24-hour period at two sensitive areas.

For the construction phase, all measured residual noise levels are lower than those provided for in *Lignes directrices relativement aux niveaux sonores provenant d'un chantier de construction industriel* (MDDELCC, 2015) (55 dBA at day and 45 dBA at night).

For the mining phase, all measured residual noise levels are lower than those provided for in Table 1 of *Directive 019 sur l'industrie minière*.

The modelling of noise and vibration levels resulting from mining activities is ongoing. If required, site-specific mitigation measures will be proposed to respect applicable noise regulations.

Surface Water and Sediments Quality

Sampling campaigns were conducted in 2010, 2015, 2016, 2017, 2021, and 2022 to characterize surface water and sediment quality of waterbodies and water courses that could be affected by mining activities. Over the years, nine waterbodies and six water courses were sampled. Because the 2022 campaign is still ongoing, the latest results presented in this section date from 2021.

The surface water results were compared to the following provincial water quality criteria: prevention of contamination of aquatic organism ("CPC[EO]"), protection of aquatic life, chronic effect ("CVAC"), protection of aquatic life, acute effect ("CVAA").

The surface water results from the 2021 campaign (six campaigns; seven stations) show that arsenic is the parameter with the most concentration exceedances. All stations had an exceedance (CPC[EO]) in at least one of the sampling campaigns, with the exception of the station WL-07 in SN1 Lake, which was only sampled in May 2021. A number of exceedances of one or several criteria were observed at some stations for iron, lead and mercury (CPAC and CPC[EO]).



The surface water results from the 2016-2017 campaign (six campaigns; seven stations) show a number of exceedances for aluminum, mercury, phosphorus, lead, zinc and pH. In the 2015 campaign (one campaign; six stations), the parameters with the most concentration exceedances were aluminum and iron. In the 2010 campaign (one campaign; four stations), the samples collected at the bottom of Windfall Lake and SN1 Lake show the most concentration exceedances for aluminum, copper and lead.

The sediments results were compared to the following federal and provincial sediments quality criteria: threshold effect level ("TEL"), probable effect level ("PEL"), rare effect concentration ("REL"), occasional effect concentration ("OEL"), frequent effect concentration ("FEL").

Sediments samples were collected in 2021 at seven stations. The results show that cadmium is the parameter with the most concentration exceedances (REL, TEL). Exceedances of mercury, lead and zinc concentrations were also observed at station WL-14 in SN2 Lake (REL, TEL). This station has the most exceedances for all criteria.

Sediments samples collected in 2017, 2015, and 2010 showed results below applicable criteria, except for two stations. The samples at SN4 station (2017) showed exceedances for mercury, and the samples at CE-5 station (2015) showed exceedances for arsenic and cadmium.

During the operational phase, management of mine water (seepage water, process water and runoff) could affect surface water quality. As described in Section 18.23, mitigation measures, including a high-performance water treatment plant, will be implemented to preserve the surface water quality.

Soil Quality

A Phase II Environmental Site Assessment study was conducted in 2022 to determine soil quality.

A total of 82 boreholes were drilled and used for continuous soil sampling. In summary, the soils analyzed had low concentrations of PAHs (<A criteria). 106 samples out of 112 had concentrations in C10-C50 petroleum hydrocarbons below the A criteria. Five samples out of 112 had concentrations in C10-C50 petroleum hydrocarbons in the A-B criteria range. One sample showed concentrations in C10-C50 petroleum hydrocarbons in the B-C criteria range. All these samples were collected in the first centimetres of soils and the concentrations in petroleum hydrocarbons should be related to natural organic matters (organic top soils).

106 samples out of 112 analyzed showed metals concentration below A criteria. Five samples out of the 112 analyzed showed metals (As, Cd, Ni, Mn, Sn and Pb) concentrations below C criteria. Only one sample showed Mn concentrations exceeding C criteria



Air Quality

The atmospheric dispersion modelling, which is ongoing, covers the construction, operation and maintenance phases of the Mine Site. Atmospheric dispersion modelling will be performed for particulate matter (PMT and PM_{2.5}), carbon monoxide ("CO"), nitrogen oxides ("NO_x"), sulphur oxides ("SO_x") as well as for 19 metals and metalloids, including crystalline silica.

20.2. Ore, Waste Rock, Tailings and Water Management Requirements

The following sections describe the environmental requirements for mining materials facilities based on available information. The Directive 019 is the main guideline for ore, waste rock, tailings and water management requirements.

20.2.1. Geochemical Assessment

An independent study is being carried out by Golder (Golder, 2023b) to define the geo-environmental properties of the ore, tailings, waste rock, and overburden to be produced by the operations at the Windfall Project related to the potential for acid rock drainage ("ARD") and metal leaching. The results are used to classify these materials according to the *Guide de caractérisation des résidus miniers et du minerai* (MELCC, 2020). Process water chemistry was also evaluated. These results are used to develop chemical loads as inputs for site water quality modelling, in progress, and are expected to be used to inform the water management and treatment plans, and the waste management plan.

Ore, tailings, and process water samples were selected and provided by Osisko. They were not independently reviewed or verified; however, the geochemical results appear to be reasonable relative to the range of values expected for the materials tested. There is some variability in material expected to be mined, relative to the samples used to evaluate tailings and process water quality. Changes in the process or mined ore relative to the sampled and tested materials will result in changes to the values observed.

In 2022, a waste rock sampling program was developed with the objective of filling in any gaps in the distribution and quantity of waste rock samples relative to the current mining plan. Previous waste rock sampling programs occurred in 2017-2018, with samples selected and collected by Golder (with the exception of the 11 Frg samples, which were selected by Osisko; however, the geochemical results for these 11 Frg samples appear to be reasonable relative to the range of values expected for the material tested). Samples for a 2020 sampling program and the above-noted 2022 program were selected by Golder, collected by Osisko, and a representative subset



were then selected for inspection by Golder; the inspected samples are consistent with expectations based on the information reviewed and the sampling process appeared to conform with Golder's written instructions. Overburden samples were collected and preliminarily tested by WSP in 2021 and 2022, with supplemental tests managed by Golder in 2022.

Aside from select overburden tests managed by WSP, all geochemical testing was managed by Golder.

The representativeness of the 2017-2022 sampling and analytical program should be periodically reevaluated and confirmed against any updates to the mine plan to confirm that an adequate number of samples have been analyzed to sufficiently characterize all units that will be mined.

It should be noted that rates of acidification presented herein are based on laboratory conditions of individual samples; these will vary under field conditions. Monitoring programs of existing and future tailings, waste rock, and overburden piles should be regularly reviewed and updated over the life of project. Geochemical predictions should be periodically reviewed and updated based on the data collected over the life of mine to provide a better estimation of the scaling from laboratory to field conditions.

Management measures account for the potential development of ARD and metal leaching in the ore, waste rock and tailings stored on the surface for several years or more, and will need to be reviewed and updated periodically if necessary.

20.2.1.1. Ore

Twenty-one composite samples of ore have been provided by Osisko from Caribou, Lynx Main, Lynx 4, Triple Lynx, Underdog, and Zone 27. The composite samples include variable lithology proportions, ore grades (low to high), and depths of ore zones when applicable (e.g., upper and lower zones for Caribou, Zone 27 and Lynx). A summary of the geochemical characterization results obtained for ore samples is presented in Golder (2023b).

The samples were classified as potentially acid generating ("PAG") and leachable for metals (arsenic, cadmium, copper, mercury, selenium, silver, and/or zinc); they were not classified as high-risk for metal leaching.

Mineral depletion calculations from kinetic testing suggest that all samples have the potential for acid generation in approximately 10 to 306 years, based on laboratory conditions.



20.2.1.2. Waste Rock and Overburden

Two hundred fifty-seven (257) waste rock samples were collected from Bobcat, Caribou, Lynx Main, Lynx HW, Lynx SW, Lynx 4, Triple Lynx, Mallard, Underdog, and Zone 27 between 2017 and 2022. Waste rock was selected based on a cut-off grade of 3 g/t of gold. The major sampled lithologies are rhyolite or felsic volcanics (V1), andesite or mafic volcanics (V2), fragmental porphyry units (I1 Frg), granodiorite dike (I2F/I13), porphyry dikes (I1P/I2P), and mafic sill (I3A). A summary of the geochemical characterization results is presented in Golder (2023).

PAG classification of waste rock is variable depending on lithology and variable within some lithologies. In general, rhyolitic or felsic volcanics (V1), andesite or mafic volcanics (V2), porphyry dikes (I1P/I2P), and sedimentary (S6) lithologies are 40 % to 60 % PAG. Granodiorite dike (I2F/I13), mafic sill (I3A), and fragmental porphyry (I1 Frg) lithologies are 87 % to 100% non-PAG. Waste rock samples were classified as leachable for metals including arsenic, copper, manganese, mercury, molybdenum, and/or silver. No samples were classified as high-risk for metal leaching.

Mineral depletion calculations from kinetic testing suggest that most waste rock samples have the potential for acid generation in approximately 2 to 304 years, based on laboratory conditions.

Two hundred and three (203) samples of overburden were collected from across the site, with depths ranging from 0 m to 4.5 m below ground surface. The overburden is classified as non-PAG. Ninety percent (90 %) of the samples had metals contents below Soil A criteria for the Superior Province (Beaulieu, 2021). Leach tests (SPLP and CTEU-9) conducted on two samples indicate the potential to leach aluminum, arsenic, copper, manganese, and silver at concentrations greater than applicable criteria (i.e., *resurgence dans l'eau de surface* [surface water recharge] and/or *eau de consommation* [drinking water]; Beaulieu, 2021); concentrations of these and several other metals parameters in leach tests were also greater than median groundwater quality from 2007 to 2022 (n=6 monitoring wells, 53 samples) and/or median surface water quality from 2016 to 2022 (n=6 monitoring locations, 27 samples). Additional work is being conducted to evaluate the metal leaching potential of the overburden.



20.2.1.3. Tailings and Process Water

Between 2017 and 2020, seven composite samples of slurried tailings and process water samples were provided by Osisko following pilot testing, to represent potential ore combinations that will be processed during the life of mine. Dry stacking of the tailings is not expected to influence the PAG classification of the materials, and is expected to have limited influence on the initial leachate chemistry results since the same solid materials will make up both types of products. A summary of the geochemical characterization results obtained for tailings and process water is presented in Golder (2023b). All samples of tailings were classified as PAG and leachable for metals including arsenic, cadmium, copper, mercury, lead, and/or zinc; they were not classified as high-risk for metal leaching. The tailings are classified as “cyanuré” (cyanide-bearing), as cyanide is used during processing. Tailings will also be used to produce paste backfill materials; this may influence the leachability of some parameters.

Mineral depletion calculations from kinetic testing suggest that most samples have the potential for acid generation in approximately 1 to 15 years, based on laboratory conditions.

20.2.2. Ore Management

Based on the geochemical characterization outcome for the ore, and as mentioned in Section 18.25.1, installation of a geosynthetic liner system for the ore stockpiles is planned. The liner system will limit infiltration of contact water to groundwater, as required by the provincial guidelines. Adequate measures to control dust and to collect and manage contact water will be implemented to all ore storage areas.

20.2.3. Waste Rock Management

Based on the geochemical characterization outcome for the waste rock, and as mentioned in Section 18.24.1, installation of a geosynthetic liner system for the waste rock stockpile is planned to allow proper groundwater protection as required by Provincial guidelines.

WSP's previous hydrogeological study of existing waste rock stockpiles included a model establishing that the proposed measures are sufficient to prevent degradation of groundwater quality even in the event of a damaged liner (2,5 holes/ha). This hydrogeological study will have to be updated to account for project changes, but no significant modifications to the proposed system are expected.



20.2.4. Tailings Management

An assessment of alternatives for mine waste disposal was completed to identify the best location for the TMF and the best suited technology for tailings management. The assessment was completed in agreement with Environment Canada Guidelines (ECCC, 2016) and also considered indications provided in provincial Directive 019 Guideline (MDDEP, 2012).

The identified preferred location for the TMF is near the process plant in an area where the topography presents a gentle slope towards the southeast. Contact water collection ponds will be located downstream of the TMF. Tailings will be managed as a dry stack (filtered material) for the duration of the LOM. No water will be allowed to pond within the facility.

The tailings are PAG, leachable for metals and cyanide-bearing. The entire area of the TMF and contact water management infrastructure will be lined with a Linear Low Density Polyethylene ("LLDPE") geomembrane to provide an adequate groundwater protection measure as required by provincial Directive 019 Guideline. Details of the proposed TMF design are presented in Chapter 18.

Closure and reclamation concept will consist in an engineered cover to limit infiltration and potentially oxygen ingress to control the acid-generating potential of the tailings. A vegetated top layer will be incorporated to allow integration in surrounding natural landscape. The TMF will be developed in three zones to promote progressive reclamation as recommended by the MERN closure guidelines (MERN, 2022).

20.2.5. Water Management

This section provides a general description of the surface water management plan and water balance for the Mine Site. A more detailed description of the water management structures at the Mine Site is provided in Chapter 18.

20.2.5.1. Mine Surface Water Management Plan

The water management strategy at the Mine Site aims to:

- Divert runoff from undisturbed areas through diversion channels, to a practicable extent;
- Collect runoff and seepage from mine facilities (mine water) in collection ponds for reuse in the mine process, with excess conveyed to the water treatment plant before discharge to the environment; and
- Collect groundwater inflows to the underground mine (part of mine water) for use in the mining process, with excess conveyed to the water treatment plant before discharge to the environment.



Runoff and seepage from different mine areas and groundwater inflows will be collected separately based on water quality, to a practicable extent.

One treatment plant will be constructed at the Mine Site, with separate treatment units to account for specific treatment requirements for the different types of mine water prior to discharge to the environment or reuse in the mining process:

- Contact water from the overburden stockpiles (collected in Pond J) and mine water from camp site and process plant areas (collected in Pond B) will be treated for TSS only.
- Contact water from the rest of the site (TMF, WRS, ore stockpile, roads) will be conveyed to a primary water treatment plant (metal/TSS) before being used for the mining process, with excess conveyed to the advanced water treatment plant (SCN-NH₄ removal) prior to its discharge to the environment.
- Underground water (from the mine) will be treated for TSS before being mixed with water from the site for metal and SCN-NH₄ treatment.

The layout of the water management infrastructure for the site is provided in Figure 20-2.

All contact water management structures are designed with a geosynthetic liner system to limit water infiltration into the ground or seepage through fill material (e.g.: dike, berm) to protect the receiving environment.

Water treatment is required to ensure that the mining effluent discharge meets the Directive 019 and the Metal and Diamond Mining Effluent Regulations ("MDMER") quality criteria. Additional environmental discharge objectives ("EDO") could be added to the previous ones. Those EDO will be defined during the permitting process. The water treatment system is described in Section 18.22.3.

Further details on the Mine Surface Water Management can be found in Golder (2023c).



The water balance model tracks inflows and outflows associated to the various mine facilities and water management structures, as well as water transfers between facilities/structures. Storage within mine facilities and water structures is estimated based on the difference between inflows and outflows. The model is set up to run on a daily time step, meaning that inflows, outflows and changes in storage are estimated for every day of the simulation period. The simulation period extends through the operations and closure phases of the Project.

Drainage from precipitation over the mine facilities was estimated based on available climate characteristics (see Chapter 5) and assumed rainfall and runoff coefficients. The progressive development of the WRS and TMF is accounted in the water balance model. Other facilities are modelled based on the final mine footprint.

Mine water at the site was divided in the following categories:

- Mine water from ore stockpile and WRS;
- Mine water from pads and haul roads;
- Mine water from the TMF;
- Water extracted from the filtration plant;
- Mine water from the overburden stockpile;
- Dewatering flows from the underground mine (see Section 16.3).

The process plant water demand is assumed to be fulfilled mainly by the water extracted from the filtration plant (clarified water tank) throughout the life of mine. The remaining make-up water at the process plant was considered to be sourced from the surface water of mine facilities (TMF, WRS, ore stockpiles and platforms/hauls roads) and underground mine dewatering.

Any amount of mine water exceeding the process plant demand was assumed to be sent to the treatment and polishing pond prior to its discharge to the environment.

Conceptual water balance flow diagrams are provided in Figure 20-3 and Figure 20-4 for two phases of the operations, corresponding to Years 1-4 (Phase 1) and Years 5-10 (Phase 2).

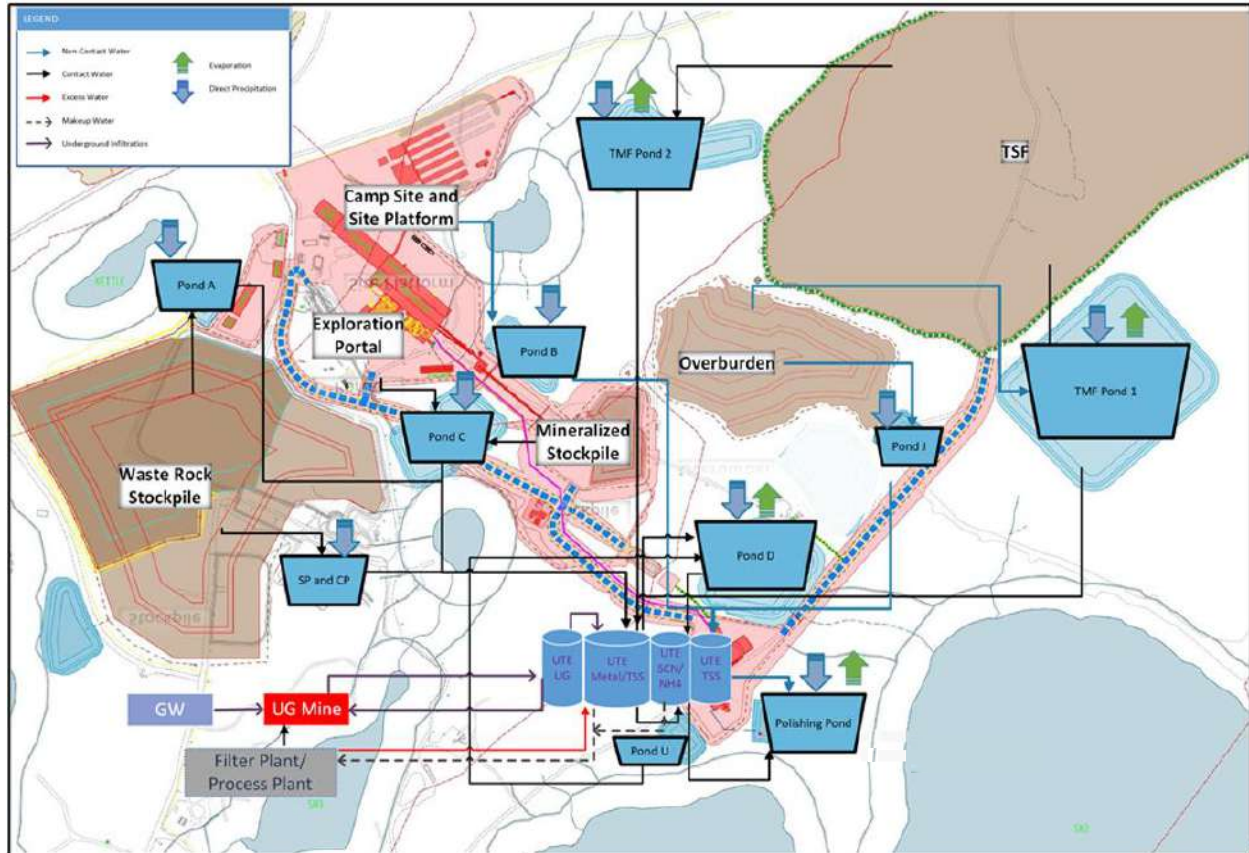

Figure 20-3: Water balance conceptual flow diagram – Phase 1

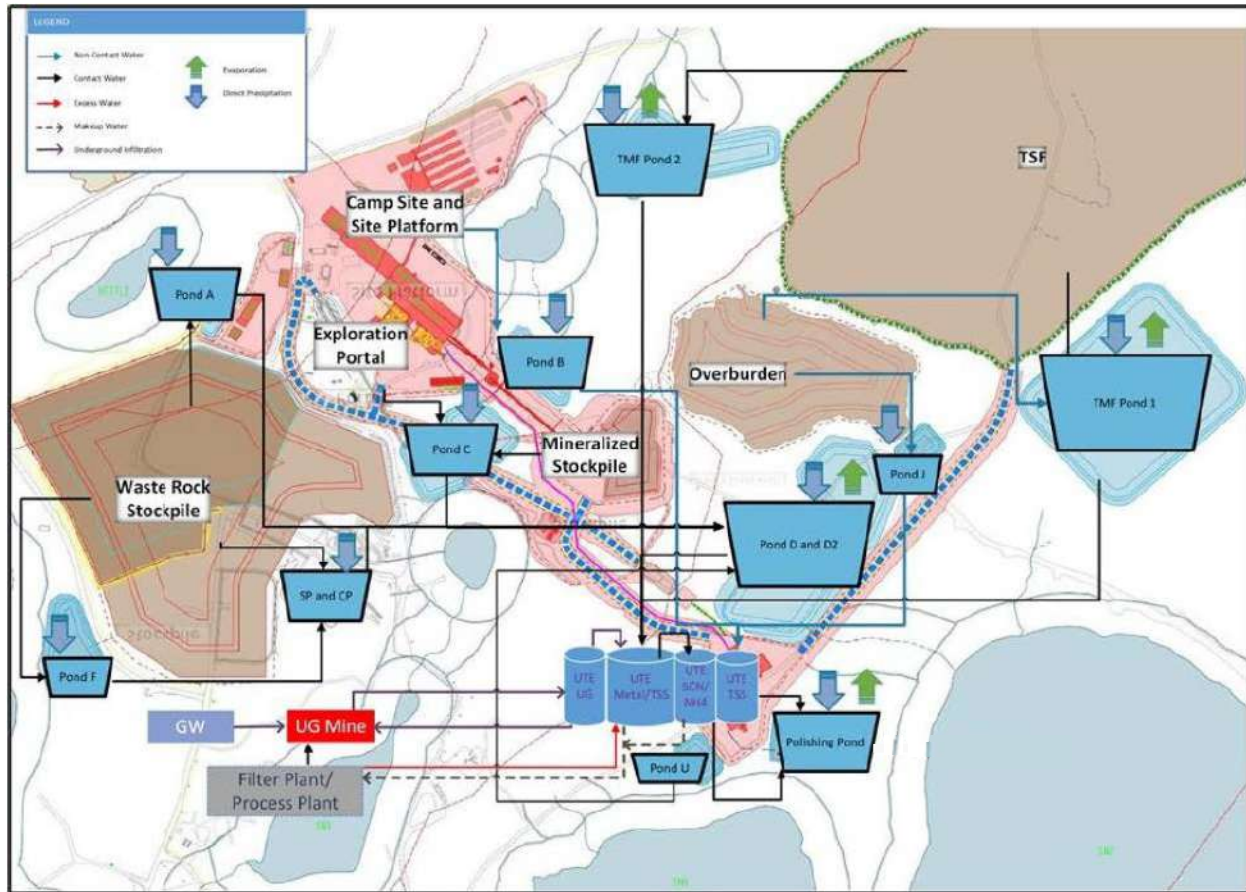

Figure 20-4: Water balance conceptual flow diagram – Phase 2

The water balance model results shows that excess water occurs during all stages and through different seasons during the operations. Table 20-1 presents, for the most critical year of each phase of operations, the monthly and annual excess water that will need to be treated and discharged at the effluent point.



Table 20-1: Estimated average and maximum monthly flow rates to water treatment units

Phase	Month	Unit	UTE UG			UTE Metal/TSS		UTE SCN-NH4		UTE TSS		Total Effluent Discharge	
			mean	mean	max	mean	max	mean	max	mean	max	mean	max
Last calendar year - Phase 1	Jan	m ³ /h	187	135	192	132	198	1	24	100	189		
	Feb	m ³ /h	187	138	243	135	214	2	42	105	229		
	Mar	m ³ /h	187	168	278	167	257	14	72	150	295		
	Apr	m ³ /h	187	239	313	243	293	67	128	309	403		
	May	m ³ /h	187	288	326	270	293	49	135	294	409		
	Jun	m ³ /h	201	250	296	273	293	32	71	274	335		
	Jul	m ³ /h	201	245	313	264	293	37	78	269	337		
	Aug	m ³ /h	201	248	330	262	293	39	109	269	373		
	Sep	m ³ /h	201	258	337	267	293	45	118	282	382		
	Oct	m ³ /h	201	246	321	264	293	37	92	270	357		
	Nov	m ³ /h	201	205	300	222	293	20	84	211	349		
	Dec	m ³ /h	201	154	296	158	293	3	19	128	268		
Annual	Mm³	1.72	1.88	2.60	1.95	2.42	0.25	0.71	1.95	2.88			
Last calendar year - Phase 2	Jan	m ³ /h	229	186	272	186	272	1	24	154	263		
	Feb	m ³ /h	229	191	350	191	350	2	43	160	365		
	Mar	m ³ /h	229	234	392	234	392	13	67	216	432		
	Apr	m ³ /h	229	409	535	385	511	65	124	448	619		
	May	m ³ /h	229	403	535	397	528	50	138	423	646		
	Jun	m ³ /h	224	330	505	330	505	32	71	331	528		
	Jul	m ³ /h	224	336	451	336	451	37	77	341	487		
	Aug	m ³ /h	224	342	520	342	520	38	108	349	597		
	Sep	m ³ /h	224	361	514	361	514	44	116	376	599		
	Oct	m ³ /h	224	346	526	346	526	37	97	352	589		
	Nov	m ³ /h	224	273	416	273	416	21	83	263	470		
	Dec	m ³ /r	224	201	327	201	327	4	23	171	303		
Annual	Mm³	1.98	2.64	3.90	2.62	3.88	0.25	0.71	2.62	4.31			

Note: Mm³ is million cubic metres

Further details on the Mine Water Balance can be found in Golder (2023d).



20.2.6. Site Monitoring

The objective of the environmental monitoring program is to detect and document any changes in the environment in relation to the baseline (whether or not related to the Project), to verify the impact assessment and to evaluate the effectiveness of the mitigation or compensation measures proposed in the impact assessment. As part of the Project, an environmental monitoring program will be implemented. Examples of components of the environmental monitoring program for the site that are legal requirements will include:

- Effluents quality monitoring (Directive 019 and MDMER);
- Groundwater quality and piezometric level (Directive 019);
- Water quality monitoring studies (including potable water and wastewater) (MDMER and Environmental Quality Act);
- Biological monitoring studies (MDMER);

An additional monitoring program could be required as a condition of an authorization delivered by the government.

20.3. Regulatory Context

The regulatory context described in the following sections is based on regulations and acts in force at the time of the preparation of this report.

20.3.1. Environmental Impact Assessment Process

20.3.1.1. Provincial Authorities

The EIA procedure in the province of Québec is divided into two regimes: Southern and Northern. The Windfall Project location falls into the Northern regime, with the provisions applicable to the James Bay region located south of the 55th parallel (EQA, Title II, Chapter II). The Project is located in the territory covered by the James Bay and Northern Québec Agreement ("JBNQA"). The projects listed in Schedule A of the EQA are automatically subject to the EIA and review procedure. Mining projects are listed in Paragraph (a) of Schedule A:

(a) All mining developments, including the additions to, alterations or modifications of existing mining developments.



Therefore, the Project must follow the environmental assessment and review procedure under the Regulation respecting the environmental and social impact assessment and review procedure applicable to the territory of James Bay and Northern Québec. As such, the environmental and social assessment is guided by the Evaluating Committee ("COMEV") and the Impact Review Committee ("COMEX").

On May 19, 2017, Osisko provided preliminary information to the MELCCFP, which was then transmitted to the COMEV. Based on the preliminary information, the COMEV formulated recommendations to the Minister regarding the scope of the assessment statement, and on August 11, 2017, the MELCCFP issued a Guideline for the preparation of an EIA statement, which was revised and reissued in January 2022. The next steps in the provincial EIA process are:

- Preparation and transmission of the EIA study to the MELCCFP according to the directions and recommendations of the Minister.
- The Minister sends a copy of the EIA study to the COMEX and to the Cree Nation Government ("CNG"). The CNG, and any Band or Cree community may, within 30 days following the reception of the EIA study by the CNG, submit representations to the COMEX. Furthermore, where the interested Band or Cree community so allows, any person interested may submit written or verbal representations to the COMEX.
- Following the reception of the EIA statement by the COMEX, the latter shall recommend to the Minister whether to authorize the Project or not and, as the case may be, on what conditions, or shall recommend that the applicant be required to carry out supplementary research or studies.
- Where the Minister is satisfied with the EIA study provided, he shall transmit a Ministerial Authorization, or a refusal, in writing. Copy of such decision is transmitted to the CNG. Conditions that the applicant must respect in the carrying out and in the operation of its project may be added to the Ministerial Authorization.

The release of the Ministerial Authorization does not affect or restrict the application of the EQA. It is the responsibility of the proponent to verify with the MELCCFP and any other municipal or government entity whether additional authorizations are required in the carrying out of the mining operations (see Section 20.3.2).

20.3.1.2. Federal Authorities

On June 5, 2017, Osisko provided a project description to the Canadian Environmental Assessment Agency (Agency). Based on the Project description, the Agency had determined, on July 31, 2017, that an environmental assessment was required under *Canadian Environmental Assessment Act, 2012* (CEAA, 2012).



On August 28, 2019, the new *Impact Assessment Act* ("IAA") came into force, along with a new set of regulations. The IAA repealed the CEEA 2012, but continues the approach taken under CEEA 2012 to designate projects by type and thresholds prescribed by regulation.

Transitional provisions in the IAA (Paragraph 181) states that:

(1) Any environmental assessment of a designated project by the former Agency commenced under the 2012 Act before the day on which this Act comes into force, in respect of which the former Agency has posted the notice of commencement under section 17 of the 2012 Act before that day, is continued under the 2012 Act as if that Act had not been repealed.

However, if the proponent does not provide the information or studies within three years after the day on which the IAA comes into force, the environmental assessment is terminated. Since that 3-year period has passed, the Windfall Project is no longer subject to the CEEA 2012. On August 29, 2022, the Impact Assessment Agency of Canada informed in writing that the Project review initiated by CEEA (2012) had been terminated.

With its average ore extraction targeted rate of 3,400 tpd and a process plant with a nominal capacity of 3,400 tpd, which are less than 5,000 tpd, it is not subject to the new IAA.

20.3.2. Permitting Requirements

Throughout all stages of the Project, activities conducted by Osisko will be required to comply with provincial and federal acts and regulations.

The next sections present the most significant acts, regulations, directives and guidelines with which the Project could be required to comply. This list is non-exhaustive and is based on information known so far. Their applicability will have to be reviewed as the Project components are defined.

The Windfall Project was selected by the Québec government as a pilot project (*Table interministérielle régionale* ("TIR")). The objective of the TIR is to work with the proponent to coordinate the issuance of the rights specific to a project. The TIR supports Osisko with the permitting process and facilitates the involvement of different ministries or government organizations based on the needs of the Project.

Provincial Jurisdiction

- *Mining Act* (M-13.1)
 - Regulation respecting mineral substances other than petroleum, natural gas and brine (M 13.1, r. 2).



- *Environment Quality Act (Q-2)*
 - Regulation respecting the regulatory scheme applying to activities on the basis of their environmental impact (Q-2, r.17.1);
 - Regulation respecting activities in wetlands, bodies of water and sensitive areas (Q-2, r.0.1);
 - Clean Air Regulation (Q-2, r. 4.1);
 - Regulation respecting the operation of industrial establishments (Q-2, r. 26.1);
 - Regulation respecting sand pits and quarries (Q-2, r. 7.1);
 - Regulation respecting compensation for adverse effects on wetlands and bodies of water (Q-2, r. 9.1);
 - Regulation respecting the declaration of water withdrawals (Q-2, r. 14);
 - Regulation respecting mandatory reporting of certain emissions of contaminants into the atmosphere (Q-2, r. 15);
 - Regulation respecting the burial of contaminated soils (Q-2, r. 18);
 - Regulation respecting the landfilling and incineration of residual materials (Q-2, r. 19);
 - Regulation respecting wastewater disposal systems for isolated dwellings (Q-2, r. 22);
 - Regulation respecting halocarbons (Q-2, r. 29);
 - Regulation respecting hazardous materials (Q-2, r. 32);
 - Water Withdrawal and Protection Regulation (Q-2, r. 35.2);
 - Land Protection and Rehabilitation Regulation (Q-2, r. 37);
 - Regulation respecting the quality of the atmosphere (Q-2, r. 38);
 - Regulation respecting the quality of drinking water (Q-2, r. 40);
 - Regulation respecting the charges payable for the use of water (Q-2, r. 42.1).
- *Act respecting threatened or vulnerable species (E-12.01)*
 - Regulation respecting threatened or vulnerable wildlife species and their habitats (E-12.01, r.2);
 - Regulation respecting threatened or vulnerable plant species and their habitats (E-12.01, r.3).
- *Watercourses Act (R-13)*
 - Regulation respecting the water property in the domain of the State (R-13, r. 1).
- *Sustainable Forest Development Act (A-18.1)*
 - Regulation respecting the sustainable development of forests in the domain of the State (A-18.1, r. 0.01).
- *Act respecting the conservation and development of wildlife (C-61.1)*
 - Regulation respecting wildlife habitats (C-61.1, r. 18).



- Act respecting the lands in the domain of the state (c. T-8.1);
- *Building Act* (c. B-1.1)
 - Construction Code (B-1.1, r. 2);
 - Safety Code (B-1.1, r. 3).
- Act respecting explosives (E-22)
 - Regulation under the Act respecting explosives (E-22, r. 1).
- *Cultural Heritage Act* (P-9.002);
- Highway Safety Code (C-24.2)
 - Transportation of Dangerous Substances Regulation (C-24.2, r. 43).
- *Occupational Health and Safety Act* (S-2.1)
 - Regulation respecting occupational health and safety in mines (S-2.1, r. 14);
 - Regulation respecting occupational health and safety (S2.1, r. 13).
- *Dam Safety Act* (S-3.1.01)
 - Dam Safety Regulation (S-3.1.01, r. 1)
- Act respecting the conservation of wetlands and bodies of water (Bill 132)(c. 14);
- Directives and Guidelines
 - *Directive 019 sur l'industrie minière* (2012);
 - *Lignes directrices relatives à la valorisation des résidus miniers* (2015);
 - Guidelines for preparing mine closure plans in Québec (2017);
 - Guide d'intervention – *Protection des sols et réhabilitation des terrains contaminés* (2021);
 - *Guide de caractérisation des résidus miniers et du minerai* (2020).

Federal Jurisdiction

- *Fisheries Act* (R.S.C., 1985, c. F-14)
 - Metal and Diamond Mining Effluent Regulations (SOR/2002-222).
- *Canadian Environmental Protection Act* (S.C. 1999, c. 33)
 - PCB Regulations (SOR/2008-273);
 - Environmental Emergency Regulations (SOR/2019-51);
 - Federal Halocarbon Regulations (SOR/2022-110);
 - National Pollutant Release Inventory.
- *Canadian Navigable Waters Act* (R.S.C., 1985, c. N22);
- *Species at Risk Act* (S.C. 2002, c. 29);
- *Canada Wildlife Act* (R.S.C., 1985, c. W-9)
 - Wildlife Area Regulations (C.R.C., c. 1609).



- *Migratory Birds Convention Act*, 1994 (S.C. 1994, c. 22)
 - Migratory Birds Regulations (SOR/2022-105).
- *Nuclear Safety and Control Act* (S.C. 1997, c. 9)
 - General Nuclear Safety and Control Regulations (SOR/2000-202);
 - Nuclear Substances and Radiation Devices Regulations (SOR/2000-207).
- *Hazardous Products Act* (R.S.C., 1985, c. H-3);
- *Explosives Act* (R.S.C., 1985, c. E-17);
- *Transportation of Dangerous Goods Act* (1992)
 - Transportation of Dangerous Goods Regulations (S.C. 1992, c. 34).
- Directives and Guidelines
 - Environment Canada Environmental code of practice for metal mines (2009);
 - Guidelines for the Assessment of Alternatives for Mine Waste Disposal (2016);
 - Strategic Assessment of Climate Change (2020).

Following receipt of the provincial Ministerial Authorization (EIA approval), the Project will require several approvals, permits and authorizations to initiate the construction phase, operate the Project and close the Project. In addition, Osisko will be required to comply with any other terms and conditions associated with the Ministerial Authorization issued by the provincial authority.

Table 20-2 presents a non-exhaustive list of required approvals, authorizations, permits or licences based on the known components of the Windfall Project and typical activities related to mining projects.

Table 20-2: Preliminary and non-exhaustive list of permitting requirements

Activities	Type of request	Authority
Closure plan	Approval	MRNF
Mining operations	Lease	MRNF
Mine waste management facilities and processing plant location	Approval	MRNF
Mine waste management facilities	Lease	MRNF
Infrastructure implantation on public land	Lease	MRNF
Construction and operation of an industrial establishment, the use of an industrial process and an increase in the production of property or services	Authorization	MELCCFP
Withdrawal of water, including related work and works	Authorization	MELCCFP
Establishment of potable, wastewater and mine water management and treatment facilities	Authorization	MELCCFP



Activities	Type of request	Authority
Work, structures or other interventions carried out in wetlands and bodies of water	Authorization	MELCCFP
Installation and operation of any other apparatus or equipment designed to treat water to prevent, abate or stop the release of contaminants into the environment	Authorization	MELCCFP
Installation and operation of an apparatus or equipment designed to prevent, abate or stop the release of contaminants into the atmosphere	Authorization	MELCCFP
Industrial depollution attestation	Attestation	MELCCFP
Carry out an activity likely to modify a wildlife habitat	Authorization	
Operation of a borrow pit	Authorization	MELCCFP
Harvest wood on public land where a mining right is exercised	Authorization	MRNF
Build or improve a multi-use road	Authorization	MRNF
Use of high-risk petroleum equipment	Permits	RBQ
Construction	Permits	RCM
Construct, place, alter, rebuild, remove or decommission a work in, on, over, under, through or across any navigable water	Approval	Transport Canada
Harmful alteration, disruption or destruction of fish habitat	Authorization	DFO
Explosives possession, magazine and transportation	Permit	SQ
Explosives transportation	Permit	NRCan
Use of nuclear substances and radiation devices	Licence	CNSC
Notice and Environmental Emergency Plan	-	ECCC



20.4. Social or Community Considerations

20.4.1. Consultation Activities

Osisko developed a communication and consultation plan that is focused on the involvement of populations affected by the Project. The continuous consultation plan aims to build meaningful relationships with the stakeholders that are likely to be impacted by the operations. This plan also ensures meaningful public participation into the impact assessment process. This plan is intended for First Nations and other local communities. Osisko has taken a proactive approach toward stakeholder consultation, holding more than 275 communication activities since 2015, primarily with the Cree First Nation of Waswanipi ("CFNW") and Lebel-sur-Quévillon communities. Information has also been shared with the communities of Matagami, Chapais, Chibougamau, Senneterre, the Lac Simon Anishinabeg First Nation and the Atikamekw First Nation of Obedjiwan, as they have expressed an interest in learning about the Project. Consultation on the Project with First Nation and Non-First Nation communities was initiated in October 2015.

The main objectives of the communication and consultation plan are to:

- Inform communities affected by the Project and gather their concerns and comments;
- Document the land use in the study area;
- Assess the foreseen social and environmental impacts of the Windfall Project;
- Communicate results of field studies;
- Improve the Project and its social acceptability by incorporating the involvement of the First Nations and other local communities into the Project design and implementation.

The approach, which integrates the communities' traditional knowledge, also wishes to facilitate the Project's harmonious integration within the receiving environment.

Several measures were implemented to meet the objectives of the communication and consultation plan. Since 2015 and up to now, the main communication activities have been conducted by Osisko. Only a part of the consultations was conducted by Osisko and its consultant.

Information sharing and consultation activities are an ongoing process that will continue throughout the Project development, the authorization process, and the construction, operation and closure phases of the Project. From March 2020 to May 2022, meetings have been held by videoconference due to restrictions related to Covid-19. Since May 2022, meetings have been held by videoconference or in person depending on the stakeholder preference.



20.4.1.1. First Nations

The Windfall Project is located on the traditional territory of the CFNW, specifically on the W25B trapline and near W25A. Between 2016 and 2022, several meetings with these tallymen and members of their families were conducted. The objective was to document: the land use in the area of the Project (main users and camps, activities, state of resources, valued areas, accessibility, etc.) and the projected use of the trapline, and the foreseen impacts and cumulative impacts related to the Project. It also aimed to gather concerns, comments and suggestions regarding the Project, and develop measures to mitigate or improve the impacts. These kinds of interviews were also held, in July 2018, with tallymen and land users using traplines along the site access road: Traplines W-24C, W-24D, W-25A, W-25B, lot 16, lot 17 and lot 19.

In October 2022, a consultation was carried out to present the Project to the tallymen and Waswanipi community members and to assess the impacts regarding transportation on the access road connecting Lebel-sur-Quévillon and the Mine Site.

Moreover, as part of its information sharing and consultation activities, the Windfall Environmental Monitoring Committee including the tallyman W25B and the Mining Coordinator from the CFNW was established in 2019. The purpose of this committee is to keep the CFNW informed about the Project, to ensure adequate consultation on the activities and answer their concerns, to present and review the sectorial reports of the Environmental Assessment, and to gather traditional knowledge and additional information on land use. Furthermore, members of the community participated in Osisko's baseline data collection field campaigns. Osisko engages on a regular basis with the CFNW (representatives and tallymen), and the Grand Council of the Crees (Eeyou Istchee)/CNG.

Osisko produced a video presenting the results of the Windfall updated 2021 Preliminary Economic Study. This video was presented to the CFNW community members and representatives (available in English and French on Osisko's social networks and web site).

Osisko also shared information on the Project development through meetings, presentations and information letters with the CFNW Council members and other CFNW stakeholders. These information and consultation meetings were held from 2017 to 2022. Members of the following organizations were notably informed and consulted in June 2018:

- Cree School Board, including the Sabtuan Regional Vocational Training Centre;
- Cree Health Board, including the Community Miyupimaatisiun Centre (Health Centre);
- Different departments of the Band Council: Cree Human Resources Development, Justice Department, Public Works, Natural Resources and the Cree Mineral Exploration Board;
- Cree Trappers' Association;
- Waswanipi entrepreneurs.



Focus groups were held with women, elders, and youth.

- Another consultation round was carried out in the fall of 2022 including the following stakeholders' groups, which were specifically targeted by the new Chief of Waswanipi:
- Tallymen;
- Chief and council;
- Waswanipi Entrepreneurs;
- Apitisiwin Skills Development ("ASD") - Waswanipi office;
- Cree School Board – including Sabtuan Regional Vocational Training Center;
- Waswanipi Cree Trappers Association ("CTA").

Steps have also been taken to meet with the Waswanipi Women's Association as well as the Youth Council; however, their election context made them unavailable. Osisko and its consultant will meet with them when they become available.

The positive impacts of the Windfall Project noted by community members from the CFNW between 2017 and 2022 are mostly related to capacity building, employment opportunities for youth and business opportunities, but subject to the protection and respect of the environment. Many community members expressed reservations, concerns and expectations regarding the genuine involvement of members of the community in the Project, the maximization of the Project benefits for the community, as well as the importance of the efficient management of environmental impacts. Other positive impacts regarding the presence of Osisko were also mentioned as possible sponsorship in the community and in-kind services for land users (e.g., road maintenance such as snow removal from the access road).

The main concerns raised by the CFNW members are the following:

- Disruptions to the environment, land use and traditional/cultural activities (mostly the tallymen);
- Potential effects on water quality;
- Impacts on all wildlife (by noise, dust, light and other pollution);
- Cumulative impacts slowly taking the Cree culture away;
- Land protection, especially lands with undisturbed forests;
- Location of the projected tailings storage facility (potential percolation into surrounding lakes);
- Incidents due to potential failure of infrastructure or equipment (e.g. leaks or spills);
- Fairness in the contracting process;
- Women's safety at the Mine Site;
- Flora conservation (e.g., reduction of blueberry plants);



- Access road safety (speeding);
- Disturbance of cultural sites and hunting periods related to the planning work activities;
- Appropriate inclusion and documentation of traditional knowledge in the EIA statement;
- Cree employment opportunities on the Mine Site;
- Social or family issues related to fly-in fly-out schedule (atypical pace of life, lack of family support and supervision for children, as well as potential failure in personal finance management due to high income and long rest periods to fall into vices);
- Personal or psychological difficulties due to harassment, difficult interpersonal relationships, racism, language barriers or addictions;
- Pressure on community structures or services.

The different consultations held by Osisko in the CFNW also intended to define or refine measures that can mitigate or improve the impacts of the Project, notably at the work camp but also on the land and in the community.

As mentioned before, the consultation and information process will continue through all the phases of the Project. Note that since 2017, a Cree liaison advisor is employed by Osisko with an office in Waswanipi to facilitate the link between the community and Osisko. Since 2018, Osisko has an onsite Human Resources Counsellor to help with the integration of First Nation and Non-First Nation workers.

20.4.1.2. Local Communities

To ensure a clear understanding of the Project and meaningful public participation, since 2017, Osisko has been sharing information on the Project development, through meetings, presentations, interviews and information letters. Activities were held in different towns in the Northern Québec region, mostly in Lebel-sur-Quévillon, notably:

- Discussion with Lebel-sur-Quévillon representatives, including a presentation to the City Council (2017 to 2022);
- Interviews with various community organizations (Cree Board of Health and Social Services of James Bay, Snowmobile Club, Youth Centre, *Réseau québécois de Villes et Villages en santé*, etc.) (2018);
- Sending of 108 letters to lease holders, followed by phone interviews (2018);
- Consultation with outfitter owners (2018);
- Two open houses (82 and 85 attendees) (2017 and 2018);
- The French version of the Project Description video was played in the Lebel-sur-Quévillon cinema preceding regular programming (2017 and 2018);
- Consultations with families holding a camp in the Project area (2017 and 2020);



- Focus groups with women and youth (2018);
- Interviews with city officials (2018);
- Meetings with local entrepreneurs and public presentation (2018);
- Presentation to members of the *Société d'aide au développement des collectivités* in Lebel-sur-Quévillon with 100 attendees (2019);
- Osisko produced a video presenting the results of Windfall's updated 2021 Preliminary Economic Study. This video was shared to Lebel-sur-Quévillon representatives (available in English and French on Osisko's social networks and web site) (2021);
- Public presentation to citizens (55 attendees) and local entrepreneurs (27 attendees) (2022);
- The Lebel-sur-Quévillon City Council visited the Windfall site (surface and underground) (2022).

As part of its public information and consultations, Osisko, as mentioned above, also held activities in other towns that could have an interest in the Project:

- Discussion with Chapais and Chibougamau representatives (2017);
- Presentation of the Project in Chibougamau (75 attendees) (2017);
- Participation to a panel in La Sarre with 90 attendees (2019);
- Discussion with Senneterre representatives (2019);
- Participation to Client and supplier Networking days organized by the *Société du Plan Nord*, including a presentation and a panel (Chibougamau 2017, Chapais 2018, virtual 2021);
- Discussions with Matagami representatives (2022).

A collaboration agreement has been reached between Osisko and the city of Lebel-sur-Quévillon in 2017. This collaborative process primarily aims to ensure transparency and effective communication with the city, to foster the social acceptability of the Project, and to maximize the socioeconomic benefits of the Project for Lebel-sur-Quévillon, all in a spirit of partnership.

As part of the collaborative committee in Lebel-sur-Quévillon, Osisko continues to maintain regular discussions with city officials, notably the:

- Mayor;
- Executive Director and Clerk;
- Director of Economic Development;
- Director of Public Works and Urban Planning;
- Executive Director of the *Administration Régionale Baie James* ("ARBJ") - since 2019.



Consultations with the public, lease owners, other stakeholders and representatives have raised different concerns and comments. The major concerns raised by the citizens of Lebel-sur-Quévillon relate mainly to the potential economic benefits for the city, business, employment and training opportunities, working conditions, incentives to attract new residents, and the Project's timetable. In 2020, during the meetings with the City Officials, the announcement of the location of the plant on the Windfall Mine Site reinforced the concerns related to economic benefits and opportunities, and the employment possibilities. The timetable regarding training and business opportunities was questioned and the need to maintain an effective and clear communication was emphasized. In August 2021, the city of Lebel-sur-Quévillon adopted a resolution to confirm the city's support to the Windfall Project and to recognize the positive benefits of the Project for the citizens and local entrepreneurs. During the public event held in Lebel-sur-Quévillon in September 2022, the citizens expressed their desire to work in collaboration with Osisko to maximize the socio-economic benefits.

As for Matagami, Senneterre, Chapais and Chibougamau, even though the Windfall Project is not on their territory, stakeholders felt that local entrepreneurs could benefit from business opportunities generated by the Project. A new consultation round was held in fall 2022 including municipal representatives, regional organizations (economic development, health, community, education) and lease owners.

20.4.2. Social Components

20.4.2.1. Land Planning, Development and Use

The Windfall Project is in the Northern Québec administrative region (Region 10), on the territory of the Eeyou Istchee James Bay Regional Government ("EIJB Regional Government"). The closest Cree community is Waswanipi, about 75 km northwest from the Windfall Project and the closest municipality is Lebel-sur-Quévillon, about 115 km west from the Windfall Project.

The Windfall Project is located on the territory under the JBNQA signed in 1975 between the Governments of Canada and Québec, the Grand Council of the Crees and the *Association des Inuits du Nouveau-Québec*.

The land regime defined in the JBNQA is a determining factor in its use. It provides for the division of the James Bay Territory into Category I, II and III lands. The Windfall Project is located on Category III lands, which are mostly public lands that are managed by the EIJB Regional Government. On Category III lands, the Crees have exclusive trapping rights (except in the southern zone), as well as certain non-exclusive hunting and fishing rights.



No federal land is located within the Windfall Project area, and no federal lands will be used for the purpose of carrying out the Project.

No established or planned protected areas are located in the Windfall Project area.

The surrounding area is used for various recreational activities such as hunting, fishing, berry picking and canoeing. In 2022, there were two recreational leases and one accommodation lease (outfitter with non-exclusive rights). Forestry and mining activities are also present in the local study area.

20.4.2.2. Traditional Land Use

Eeyou Istchee involved Cree Community

Eeyou Istchee, or the Crees' traditional territory, is the Cree represented portion of the EIJB Regional Government. Eeyou Istchee is located in the administrative region of Nord-du-Québec and covers a land area of approximately 5,271 km² (MAMH, 2010). It includes nine Cree communities (from north to south: Whapmagoostui, Chisasibi, Wemindji, Eastmain, Nemaska, Waskaganish, Mistissini, Oujé-Bougoumou, Waswanipi) (CNG, 2022a). The largest community is Chisasibi, with a population of nearly 5,000 people (CNG, 2022b).

The Cree community of Waswanipi is the main one involved in the Project. The local study area overlaps two traplines: W25B (camp within the local study area) and W25A. The land use on the traplines is dominated by the hunting, fishing, trapping and berry picking activities of the tallymen (mostly W25B), who stay at their camps almost year-long, and their families, who visit seasonally or sporadically (personal communication, 2018). There are also non-Cree camps that are being used sporadically for fishing, ice fishing and moose hunting activities.

Some valued areas (wood and mountain for moose hunting) as well as two burial sites were identified on the traplines by the tallymen to be protected and untouched (personal communication, 2018).

20.4.2.3. Population and Economics

The population of the EIJB Regional Government was estimated at 32,097 people in 2021, of which 18,679 were from Eeyou Istchee communities and 13,418 were from Jamesian communities (ISQ, 2022a).



Eeyou Istchee Community

In 2021, the Cree community of Waswanipi had a population of 1,836 people (Statistics Canada, 2022). Waswanipi's demographic situation is primarily characterized by its large proportion of people under 15 years old (27 %). (Statistics Canada, 2022). A population growth (14 %) is also expected for this community between 2026 and 2041 (ISQ, 2021).

The Cree First Nation of Waswanipi is represented by a Band Council managed by a Chief, a Deputy Chief, and seven councillors (INAC, 2022). The current Chief was elected in September 2022.

Waswanipi also has a high-employment rate in the primary sector (10 %), in comparison to the province of Québec (3 %) (Statistics Canada, 2017).

Jamesian Communities

With 7,233 inhabitants (2021), Chibougamau had the largest population in the region, while Lebel-sur-Quévillon had a population of 2,091 people (2021) (Statistics Canada, 2022). The population of Lebel-sur-Quévillon has slightly decreased since 2016 (-4 %), and this decline is expected to continue until 2041 (Statistics Canada, 2017; ISQ, 2021).

The industrial structure of Lebel-sur-Quévillon is characterized by a high proportion of jobs in the primary sector (27 %) (Statistics Canada, 2017). In this area, the economy revolves essentially around three resources: energy, mines and forests.

20.4.2.4. Archaeology and Heritage

There are no known archaeological manifestations within the Project's area (Archéo-08, 2018).

An evaluation of the archaeological potential was completed in 2007 by an archeologist (Archeo-08, 2007). When an area presented a potential, it was rated low, medium or high. Stream banks are considered to have high archeological potential. They hold characteristics that are conducive to human occupation and are also located within areas historically used by First Nations for their livelihood activities. Areas likely to contain portage trails were considered to have a medium archeological potential. The report also states that very little is known regarding the archeology of the Windfall Project region.

Archeological surveys were performed in 2017-2018 in high-potential areas that could be affected by planned exploration activities (Archéo-08, 2018). No artefacts or archeological sites were found. Two family members of the tallyman's family (W25B) participated in the field activities. there is currently another study of archaeological potential in progress which will cover an area that had not been studied in 2007 and 2017-2018. This information will complete the information on the receiving environment for the area covered by the various future mine facilities.



20.4.2.5. Landscape

The Windfall Project is located in a natural landscape, typical of the lower Abitibi plateau. It is shaped by a mosaic of forests, lakes, rivers and vast wetlands that are part of the Opawica River watershed. This natural landscape is disturbed by some high-voltage power lines, forestry activities and a few existing mining infrastructure. Observers are limited to a few cabins along the lakes and to land users. The new mining infrastructure will modify part of this natural landscape, and of the visual field of observers. Mitigation measures like the preservation of forest cover, the infrastructure configuration and a progressive site restoration program will be put in place to minimize the potential effects on the landscape and the visual fields of observers.

20.4.2.6. Economic Benefits Assessment

A study on economic benefits assessment is also ongoing as part of the EIA process. The conclusion of that study will be integrated to the EIA statement.

20.4.3. Social Related Requirements

20.4.3.1. Engagement Activities Requirements

The Provincial government recommends that project initiators engage in good faith, as soon as possible, in a process of information and consultation with locals and First Nation communities, with an approach based on respect, transparency and collaboration. The MELCCFP published the *Guide sur la démarche d'information et de consultation réalisée auprès des communautés autochtones par l'initiateur d'un projet assujéti à la procédure d'évaluation et d'examen des impacts sur l'environnement* (MELCC, 2020) for the implementation of an information and consultation process with Indigenous communities for projects subject to the EQA assessment and review procedure. The *Ministère de l'Énergie et des Ressources naturelles* (now MRNF) also published a Native Community Consultation Policy specific to the mining sector (MERN, 2019).

Also, both the James Bay Advisory Committee on the Environment ("JBACE") and the COMEX published guidelines for consultations and public engagement activities (JBACE, 2019; COMEX, not dated).

Consultation and communication activities with the stakeholders were initiated in 2015 and are ongoing, notably with the CFNW and the municipality of Lebel-sur-Quévillon (see Section 20.4).

In accordance with the *Mining Act*, Osisko will have to establish a monitoring committee to foster the involvement of the local community. The committee must be established within 30 days after the mining lease is issued and must be maintained until all the work provided for in the closure plan has been completed. The lessee determines the number of representatives who are to sit on



the committee. However, the committee must include at least one representative of the municipal sector, one representative of the economic sector, one member of the public and, if applicable, one representative of an Indigenous community consulted by the Government with respect to the Project.

20.4.3.2. Agreements

The previous owner of the Windfall property (Eagle Hill Corporation) held several information meetings with CFNW representatives, including former Chief Paul Gull. These meetings led to the signing, in 2012, of an Advanced Exploration Agreement with the CFNW, the Grand Council of the Crees and the Cree Regional Authority. Osisko continues to honour the terms of the 2012 Advanced Exploration Agreement. Among other things, the Agreement stipulates the negotiation of a Social and Economic Participation Agreement (an Impact and Benefit Agreement, or "IBA") if the Project is shown to be economically viable. Discussions are underway with Waswanipi and the Cree Nation Government representatives and preliminary negotiations for an IBA commenced on December 19, 2017, in Waswanipi.

Osisko signed a Collaboration Agreement with the city of Lebel-sur-Quévillon in 2017. This process aims to ensure transparency and effective communication with the city, to foster the social acceptability of the Project, and to maximize its socio-economic benefits for Lebel-sur-Quévillon, all in a spirit of partnership. Since 2019, the ARBJ has also attended the Collaboration Committee meetings.

20.5. Mine Closure Requirements

Québec regulating authorities have established requirements for mine site closure and rehabilitation in the province of Québec. A person, or entity, who performs exploration or mining work is required, under the *Mining Act*, to submit a closure plan to the MRNF for approval and must carry out the work detailed in the plan within 3 years after the end of mining operations on the site. The approval of the plan is conditional to the issuance of the mining lease and the beginning of mining operations.

In addition to the *Mining Act*, the MERN published in 2017 and MRNF in 2022 the Guidelines for Preparing Mine Closure Plans in Québec (MRNF, 2022), which details the Minister's requirements for mine rehabilitation works. The main objectives of these works, as stated by the MRNF are the following:

- Eliminating unacceptable health hazards and ensuring public safety;
- Limiting the production and spread of contaminants that could damage the receiving environment and, in the long term, aiming to eliminate all forms of maintenance and monitoring;



- Returning the site to a condition in which it is visually acceptable (reclamation);
- Returning the infrastructure areas (excluding the tailings impoundment and waste rock piles) to a state that is compatible with future use (rehabilitation).

Furthermore, as per the *Mining Act*, the proposed works must include the following:

- The rehabilitation and restoration of accumulation areas;
- Geotechnical soil stabilization;
- The securing of openings and surface pillars;
- Water treatment; and
- Road-related work.

Indirect costs, such as engineering, supervision fees and site monitoring must also be considered.

A financial guarantee to cover the anticipated costs of completing the works proposed in the closure plan as well as a contingency representing 15 % to 30 % of the closure costs must be submitted before the start of the mining operations and is withheld until closure works have been completed to the satisfaction of the MRNF.

The closure plan must be revised every 5 years or whenever changes to the mining activities justify the revision of the content or cost estimation of the closure plan.

20.5.1. Closure Concept

The proposed reclamation works for the Windfall site are described below and are proposed with the intent to ensure the site is returned to a natural appearance and integrates to the surrounding environment while limiting the production and transport of contaminants and erosion. All of the activities described are included in the closure cost estimate.

All buildings and surface infrastructure will be dismantled, including water management facilities, electrical and support infrastructure, unless it is shown that they are necessary to achieve and maintain a satisfactory condition, or to support the area's socio-economic development. The openings of raises, declines or all other means of access to underground worksites will be secured.

All areas affected by mining operations (for example, industrial areas, TMF, waste rock piles, and road surfaces and water management infrastructure) will be revegetated to control erosion and to return the site to a natural appearance integrated in the surrounding landscape. Before the revegetation of the affected areas, a characterization study certified by an expert authorized under section 31.65 of the EQA must be submitted to the regional branch of the MELCCFP. If the study reveals the presence of contaminants in a concentration exceeding the regulatory limit values, a land rehabilitation plan must be submitted for approval.



The accumulation areas, including the waste rock stockpile and the tailings management facility will be reclaimed to ensure geotechnical stability and to prevent acid mine drainage ("AMD"). The reclamation concept for the TMF and the waste rock stockpile consists in the implementation of an engineered cover.

Water management infrastructure, such as the WTP, ponds and ditches will be emptied, breached and levelled to limit the accumulation of water and to recreate a natural surface water runoff.

A post-closure monitoring and maintenance program will have to be carried out, as per the requirements of the MRNF, to ensure the physical stability of all infrastructure and the effectiveness of the remedial measures implemented. The cost for these monitoring programs is included in the closure cost estimates. The proposed post-closure monitoring and maintenance program includes:

- a. A physical stability (geotechnical) monitoring and maintenance program;
- b. An environmental monitoring program;
- c. An agronomical monitoring program.

For the purpose of the sustaining CAPEX within the scope of this Feasibility Study, the cost to rehabilitate the Windfall Project site is estimated to \$83.3M, including the direct and indirect costs. This cost includes site rehabilitation and restoration as well as the post-closure monitoring, as described above.

The cost aforementioned may be different from the financial guarantee required by the Ministry.



21. Capital and Operating Costs

The capital and operating cost estimates presented in this FS for the Windfall Project are based on the construction of one underground mine, a process plant and a tailings management facility based at the Windfall site. The process plant will treat a daily average of approximately 3,400 tpd.

All capital and operating cost estimates cited in this report are referenced in Q4 2022 Canadian dollars.

21.1 Capital Costs

21.1.1 Summary

The total pre-production capital cost for the Windfall Project is estimated to be \$788.6M (including contingencies and indirect costs). The total does not include a total of \$146.5M for:

- Sunk costs spent prior to the feasibility study for the purchase of the process plant grinding mills (\$5.6M) and the environmental impact study (\$1.1M);
- Long lead expenses planned before the start of construction, including mechanical and electrical packages (\$57.0M), camp (\$32.2M), material opportunity purchase (\$8.0M), mining fixed equipment (\$2.9M), detailed engineering (\$33.3M), logistics and warehousing (\$2.1M), and contingency (\$3.0M).

The cumulative life of mine capital expenditure including costs for pre-production, sustaining, site reclamation, closure and salvage value is estimated to be \$1.4B. Figure 21-1 provides an overview of the capital costs (pre-production and sustaining) on an annual and cumulative basis for the life of the Project.



Table 21-1: Project pre-production capital cost summary¹

Area	Description	Pre-production capital cost (\$M)	Sustaining capital cost (\$M)	Total cost (\$M)
000	General administration (Owner's costs)	175.7	1.3	177.1
200	Underground mine	80.2	556.7	636.9
300	Mine surface facilities	0.0	3.7	3.7
400	Electrical and communication	14.7	-	14.7
500	Site infrastructure	63.9	-	63.9
600	Process plant	273.8	-	273.8
800	Waste, water and tailings management	69.5	26.0	95.5
900	Indirect costs	61.3	-	101.1
999	Contingency	49.5	-	49.5
	Total	788.6	587.6	1,376.2
	Site reclamation and closure	-	83.3	83.3
	Salvage value	-	(18.7)	(18.7)
	Total	788.6	652.3	1,440.8

1- Capital costs do not include sunk costs and long lead expenses totalling \$146.5M

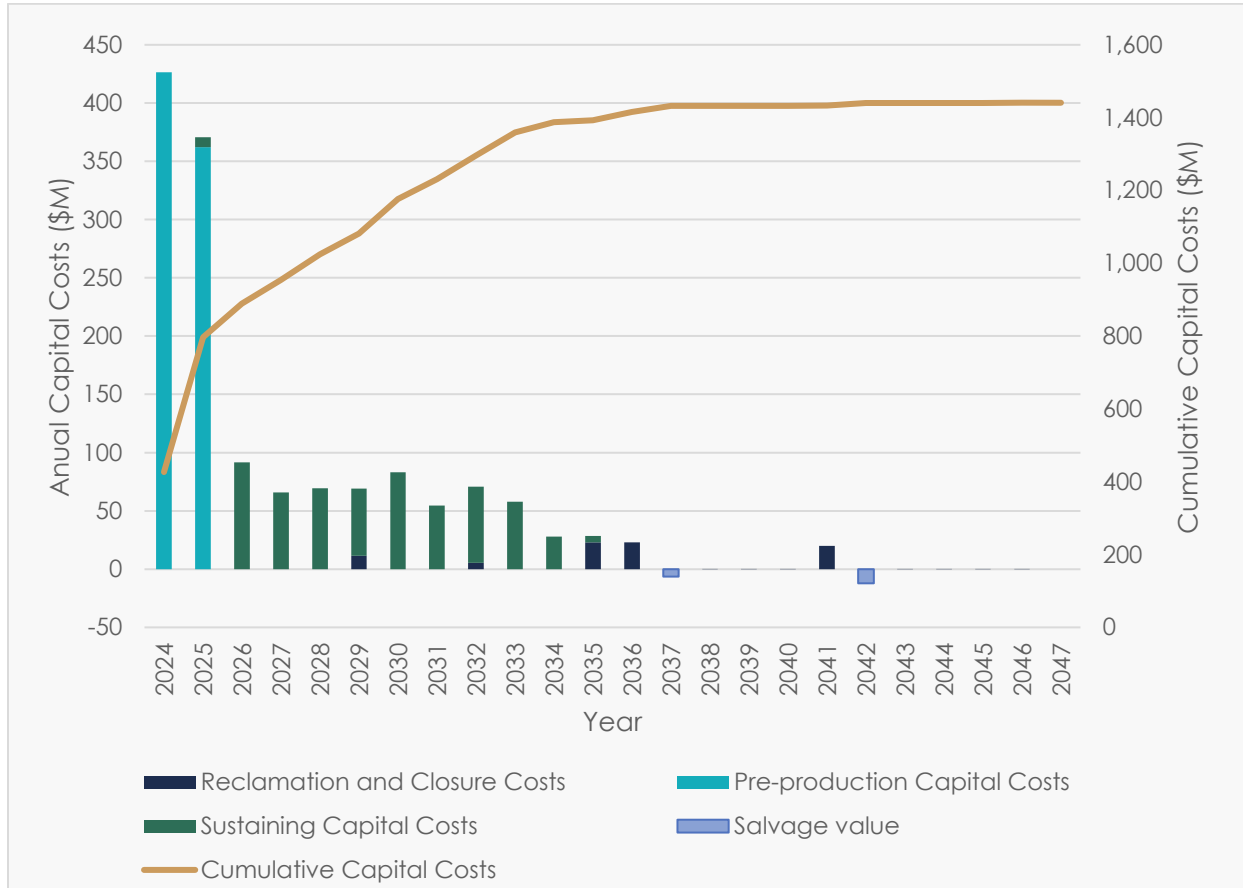

Figure 21-1: Annual and cumulative project capital costs

21.1.2 Scope and Structure of Capital Cost Estimate

The overall capital cost estimate developed in this FS meets the Association for the Advancement of Cost Engineering ("AACE") Class 3 requirements and has an accuracy range of between -10% and +15%. The capital cost estimate for this study is meant to form the basis for an overall project budget authorization and funding, and as such, forms the "Control Estimate" against which, subsequent phases of the Project will be compared and monitored.

The capital cost estimate abides by the following criteria:

- Reflects general accepted practices in the cost engineering profession;
- Assumes contracts will be awarded to reputable contractors on a cost reimbursable basis;
- Labour costs are based on the current Québec Industrial construction collective bargaining agreement;



- Winter conditions are expected between the months of October and April. This is incorporated within the Project productivity factors;
- Pre-production capital costs are expressed in constant Q4 2022 Canadian dollars ("CAD"); with an exchange rate of 1.00 CAD for 0.77 US Dollar ("USD").

The Project schedule, from the feasibility study, detail engineering to start-up, was also used in the preparation of the estimate. Refer to Chapter 24 for the execution plan and schedule. The decision to proceed with construction of the Project is expected to be made in Q2 2024. Any capital expenditures already made or planned before this date are not included in this capital cost estimate. The cost estimate was divided into the following elements:

- Pre-production Capital Costs:
 - Owner's costs (WBS 000 General Administration): costs associated with the project-specific personnel, management, support infrastructure, safety and environmental, community relations, administration and finance, human resources, training and others;
 - Direct costs (WBS 200 to 800): costs for productive works and permanent infrastructure. Includes productive infrastructure, services and equipment required for the extractive process;
 - Indirect costs (WBS 900): costs needed to support the construction of the facilities included in the direct costs. Including remaining engineering, procurement and construction management ("EPCM") activities, EPCM temporary facilities (infrastructure) and construction management, capital spare parts, freight and logistics;
 - Contingency (WBS 999): includes variations in quantities, differences between estimated and actual equipment and material prices, labour costs and site-specific conditions. Also accounts for variation resulting from uncertainties that are clarified during detailed engineering, when basic engineering designs and specifications are finalized.
- Sustaining Capital Costs:
 - Capital expenditures after the start of operations: include costs for waste rock stockpile expansion, surface tailings expansion and ponds construction, underground mine extensions and associated infrastructure, production equipment replacement, and closure costs. These costs are included in the financial analysis, in Chapter 22, in the year in which they are incurred. Capital costs after Q3 2025 are classified as sustaining capital.

21.1.2.1 Work Breakdown Structure (WBS) and Estimate Responsibilities

The capital cost estimate was developed in accordance with Osisko's work breakdown structure ("WBS") with the estimate responsibilities summarized in Table 21-2.



Table 21-2: CAPEX estimate responsibilities by WBS

WBS area	Description	Responsible entity
000	General administration (Owner's cost)	Osisko, BBA, Entech and WSP
200	Underground mine	Entech
300	Mine surface facilities	WSP
400	Electrical and communication	BBA
500	Plant site infrastructure	WSP
600	Process plant	BBA and WSP
800	Waste, water and tailings management	GCM, WSP, and Golder
900	Indirect costs	Osisko and BBA
999	Contingency	Osisko and BBA
	Site closure and reclamation	WSP
	Salvage value	BBA and WSP

21.1.2.2 Exclusions

The following items were excluded from the capital cost estimate:

- Certain land acquisitions;
- Licensing and financing costs;
- Project development costs incurred to date, including studies, sunk costs and long lead expenses;
- Taxes (included in the financial model);
- Geotechnical anomalies (must be considered as risk);
- Pre-operations testing and start-up beyond C4 certificate;
- Operating costs;
- Changes to design criteria;
- Work stoppages;
- Scope changes or an accelerated schedule;
- Hydrological, environmental or hazardous waste issues;
- Costs relating to certain agreements with third parties.



21.1.3 Pre-production Capital Costs

The pre-production capital cost summary for the Project is \$788.6M as outlined in Table 21-3 and shown as a pie chart in Figure 21-2. The capital cost breakdown descriptions are outlined in the following sections. The pre-production capital costs do not include a total of \$146.5M for sunk costs and long lead expenses (refer to Section 21.1.1).

Table 21-3: Project pre-production capital cost summary

Area	Description	Total cost (\$M)	CAPEX (%)
000	General administration	175.7	22.3%
200	Underground mine	80.2	10.2%
300	Mine surface facilities	0.0	0.0%
400	Electrical and communication	14.7	1.9%
500	Site infrastructure	63.9	8.1%
600	Process plant	273.8	34.7%
800	Waste, water and tailings management	69.5	8.8%
900	Indirect costs	61.3	7.8%
999	Contingency	49.5	6.3%
	Total	788.6	100.0

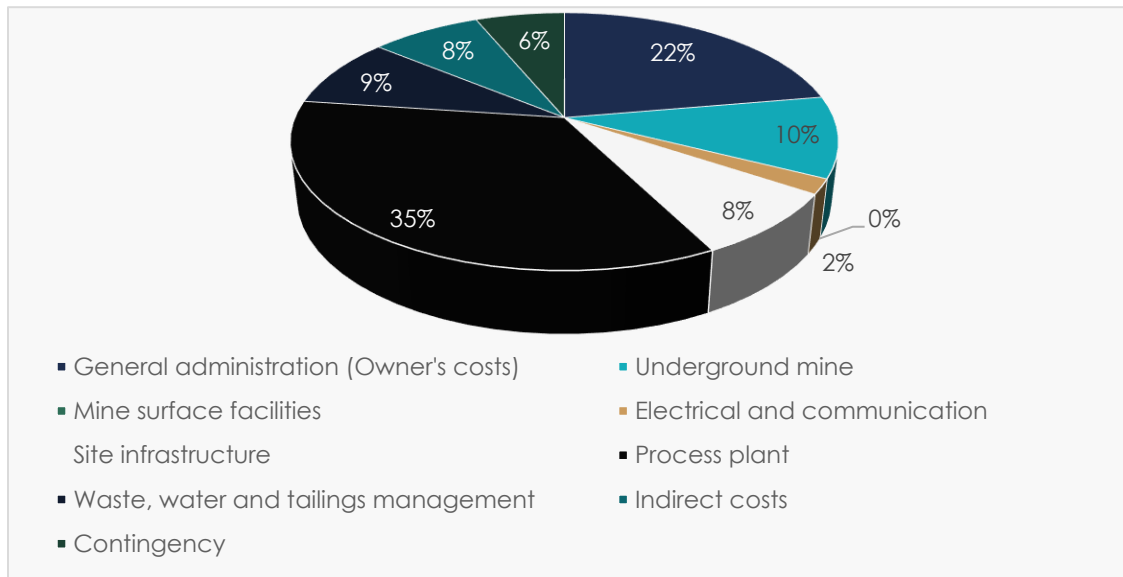

Figure 21-2: Distribution of pre-production capital costs



21.1.3.1 Direct Costs (Areas 000 to 800)

The overall pre-production capital direct costs (WBS Areas 000 to 800) for the Windfall Project total \$677.8M. The pre-production capital costs do not include a total of \$146.5M for sunk costs and long lead expenses as described in Section 21.1.1).

Direct cost details, based on the previously described assumptions, construction crew wages and productivities for the mine, process plant, site infrastructure, and waste, water and tailings management are provided in the following sections according to the Project WBS.

21.1.3.1.1 General Administration (Area 000) – Owner's Costs

The following items are part of the General Administration area, representing the Owner's costs during pre-production:

- Employee salaries until production begins;
- Energy, consumables and maintenance costs during mine development;
- Insurance during pre-production;
- Surface mobile equipment for the site and the warehouse;
- Environmental management and mitigation;
- Security;
- Pre-investment costs;
- Personnel training;
- Administration, financial and human resources costs;
- Community relations.

Owner's costs total \$175.7M. Table 21-4 summarizes the General Administration pre-production capital costs.



Table 21-4: General administration (Owner's costs) pre-production capital cost summary

Description	Total cost (\$M)	CAPEX (%)
General management	67.5	38.4
Mine pre-production Owner's costs	91.5	52.1
Process plant pre-production Owner's costs	13.4	7.6
Insurance	2.4	1.4
Mobile equipment	1.0	0.6
Total	175.7	100.0

21.1.3.1.2 Exploration and Geology (Area 100)

Exploration and geology work for the Windfall Project was completed prior to the effective date of the FS and is thus considered part of the Early Works. The exploration and geology costs have not been included in the pre-production capital costs.

21.1.3.1.3 Underground Mine (Area 200)

Entech provided estimates for all underground mine capital costs. The total underground mine pre-production capital cost is \$171.7M for the Windfall Project. Underground mine Owner's costs (\$91.5M) are included in the General Administration cost centre, as mentioned in Section 21.1.3.2 Table 21-5 summarizes the pre-production underground capital costs and provides a breakdown per item. Pre-production capital costs include material, consumables, mobile and fixed equipment, maintenance and labour for each category.

Material and consumable requirements were calculated from first principles, where total quantities of each type were determined and costed based on recent supplier quotes.

Equipment maintenance costs were based on preventative maintenance schedules and costs provided by equipment manufacturers, as well as an allowance for additional consumables in the case of fixed equipment.

Labour requirements were determined based on equipment operator needs and support positions quantified based on agreement between Entech and Osisko. Labour costs were provided by Osisko as described in Section 21.2.2.

No contingency has been applied to the mining costs.



Table 21-5: Underground mine pre-production capital costs

Description	Total cost (\$M)	CAPEX (%)
Underground mine general	0.04	0.0
Mine development	29.8	37.1
Underground infrastructures	12.1	15.1
Main ventilation	1.3	1.6
Paste backfill	4.2	5.3
Underground water management	0.6	0.7
Underground electrical substation	4.2	5.3
Underground mine mobile equipment	28.0	34.9
Total	80.2	100.0

21.1.3.1.4 Mine Surface Facilities (Area 300)

No items were costed for this area.

21.1.3.1.5 Electrical and Communication (Area 400)

The electrical and communication site-wide distribution networks and site telecommunications and IT/OT systems capital costs were estimated by BBA. These costs account for telecommunications and IT/OT systems designed to support an integrated operations centre ("IOC") with surface and underground connectivity using fibre optic and Private LTE technology. Internet connectivity will be provided by a primary optical ground wire ("OPGW") fibre-optic WAN link and secondary hybrid microwave/fibre-optic WAN link.

An equipment list, including capacities and sizing, has been developed from the electrical single-line diagram. Material take-offs ("MTOs") for electrical bulk quantities were prepared by sub area based on similar installations designed by BBA. Major electrical equipment costs were estimated using budgetary proposals obtained from suppliers, except for the Ball mill and SAG mill motors and drive for which a firm proposal was obtained. Electrical equipment of lower monetary value was estimated from BBA's recent project data. Electrical bulk material pricing was obtained from BBA's historical data. Lighting and small power distribution have been estimated by factoring other projects and based on the surface area.

The electrical power line and associated infrastructure supplying power to the site is not included in this cost area as it will be supplied by subsidiaries of the Cree First Nation of Waswanipi ("CFNW").



The total capital cost for electrical and communication is estimated to be \$14.7M.

The Windfall Site electrical and communication capital costs are shown in Table 21-6:

Table 21-6: Electrical and communication pre-production capital costs

Description	Total cost (\$M)	CAPEX (%)
Electrical site distribution	4.5	30.8
Emergency generator	0.2	1.4
Communication / IT & OT system	10.0	67.8
Total	14.7	100.0

21.1.3.1.6 Site Infrastructure (Area 500)

The site surface infrastructure capital costs were estimated by WSP. The capital costs for the site infrastructure were determined by engineering design for all disciplines to define material take-offs, based on neat quantities, with applied factors for waste. However, no design growth factor was applied on these quantities. The total capital cost of the site infrastructure facilities is estimated to be \$63.9M.

Assumptions used to determine the capital cost of site infrastructure include the following:

- The Windfall site is accessed using existing roads, which implies only maintenance costs;
- Fire protection system costs are included in the capital costs for each building (where it is required);
- Buried piping costs were estimated using a site layout and each of the building's requirements;
- Camp complex costs are not included as they are considered as long lead item expense since Osisko is planning to invest in this infrastructure in the upcoming year. Site preparation and services costs are, however, included in this cost area;
- Potential borrow pits were identified for both access road maintenance and site works, and hauling distances were considered in costs;
- Aggregate will be produced near the site, using a mobile crushing and screening plant.

A summary of the site surface infrastructure capital costs is provided in Table 21-7.



Table 21-7: Site infrastructure pre-production capital costs

Description	Total cost (\$M)	CAPEX (%)
Plant site infrastructures general	7.0	11.0
Site preparation	2.7	4.2
Public road	1.0	1.6
Site road	5.2	8.2
Site access control	1.1	1.7
Accommodations camp site preparation and services	11.8	18.4
Truck shop	19.5	30.5
Services/Core shack building	7.3	11.4
Fuel storage facility	0.7	1.1
Fire protection system	3.2	5.1
Potable water	2.0	3.1
Sewage disposal	2.0	3.1
Cultural center	0.4	0.6
Total	63.9	100.0

21.1.3.1.7 Process Plant (Area 600)

Process Plant Earthworks

The process plant site preparation and pad foundations capital costs include crusher's access ramp and ROM pad and were estimated by WSP. The capital costs were determined by engineering design, which allows material quantities calculations. However, no design growth factor was applied on these quantities and the structural excavation / backfill underneath buildings were considered by BBA. The total capital cost of the process plant earthworks is estimated to \$11.2M.

Main Process Plant (Areas 601 to 685)

The design of the process plant was based on engineering deliverables developed to a level of definition consistent with the requirements of a Class 3 estimate as per AACE classification. All quantities were generated by BBA Engineering based on a combination of 3D model, detailed lists and material take-offs. Engineering quantities were neat (exclusive of waste, contingency, or growth).

The estimate reflects a detailed bottoms-up approach with detailed material take-offs provided for each engineering discipline. Estimate line items include quantity adjustments for connections



factors and growth, site installation hours and labour costs and permanent material and equipment costs. Labour crew rates and productivity factors were developed specifically for the Project based on a 10-hour work day and site rotation of 2 weeks on / 1 week off. The cost estimate includes the equipment and materials for tailings discharge from the process plant and water reclaim from the tailings management facility ("TMF"). The cost estimate excludes the primary grinding mills (\$7.2M), as they have been purchased before the feasibility (Sunk Cost), and long lead expenses of (\$45.1M).

The total capital cost of the process plant facility is estimated to be \$186.4M, as summarized in Table 21-8.

Table 21-8: Process plant pre-production capital costs

Description	Total cost (\$M)	CAPEX (%)
Site works	3.2	1.7
Concrete activities	42.2	22.6
Structural elements	23.4	12.6
Architectural finishes	13.0	7.0
Mechanical - Process - Equipment	48.7	26.1
Mechanical - Building - Utilities	9.9	5.3
Piping	13.1	7.0
Electrical	19.7	10.6
Automation	13.2	7.1
Total	186.4	100.0

The following sections provide the basis for the capital cost estimates for the major component costs of constructing the process infrastructure.

- Civil

Civil quantities were provided by engineering from arrangement drawings supported by additional calculations and sketches made to define earthworks, structural excavation and backfill.

Underground utilities quantities were evaluated based on design and general routing indicated on the plot plan, plant layout and general arrangement drawings.

Earthworks were priced using unit rates from BBA historical data for the local conditions.



- Mechanical

A detailed equipment list, including platework, was developed from the process flow diagrams and P&ID's. Budgetary pricing was obtained for the majority of process equipment with the balance of equipment based on in-house pricing from recent project data. All pricing has been entered in native (quoted currency) and converted to Canadian dollars as per the exchange rates provided by Osisko.

Equipment pricing in the direct costs is exclusive of freight, spare parts, or vendor assistance which are captured in the indirect project costs.

- Mechanical Services

Engineering have prepared a MTO for mechanical services covering HVAC, fire protection, storm drainage and sanitary drainage in and around buildings, and plumbing. Material and equipment pricing were evaluated as per BBA's historical data from similar projects or studies, adjusted for this Project apart from ductwork which is based on a quotation by a specialized contractor.

- Concrete

Concrete quantities were estimated from preliminary design calculations and/or the 3D model, where applicable. Concrete volumes were estimated by type (footings, piers, columns, walls, slab on grade, equipment foundations). Foundations for major process equipment were identified separately, whereas the balance of equipment foundations were grouped for a particular process area.

Concrete cast-in place pricing rates were built-up for each type of concrete with formwork and rebar densities based on historical data. Rebar pricing includes supply and shop fabrication as part of the material price. The cost of concrete supply is based on informal pricing received from local suppliers or batch plant operator.

- Structural and Architectural

Engineering provided steel MTOs for all process buildings, based on extraction from the 3D model. Structural steel fabrication costs are based on in-house pricing from recent project information.

- Piping

Engineering have provided a detailed MTO based on an extraction for modeled pipe and estimated length for non-modeled pipe. The MTO includes the diameter, fluid code, pipe specification, material type and complexity factor (fitting count per 100 ft). A manual valve list was also provided.



Pricing is based on in-house resources and recent project data.

- Electrical

Engineering have specified the quantity and sizing of major electrical equipment in the electrical equipment list. Electrical distribution quantities were evaluated by the electrical engineering department based on electrical layout drawings, site electrical distribution layout, main substation layout, motor lists, cable lists, and single-line diagrams.

The cost of bulk materials pricing is based on recent project data. Electrical equipment costs are supported by budgetary quotations from established suppliers.

- Automation

Instrumentation quantities were evaluated by the automation engineering department based on PID's, instrument lists, network drawings and GA's. The list generated included detailed itemization of instruments and control valves.

Prices for bulk materials and components are based on BBA's historical data.

Costs for fire detection and communications systems were based on similar industrial projects.

- Construction Labour

Installation labour costs at Windfall are based on a 10-hour work day and a rotation of 2 weeks in and 1 week out.

Wage rates were established based on the Québec construction industry labour agreement of hourly labour costs for industrial projects in accordance with the collective institutional/commercial and industrial sectors for 2022.

Composite crew wage rates were established for each commodity based on a crews comprised of foreman, journeymen, apprentices and general labour across all construction trades. The composite crew rates include the following costs:

- Base rates fringe benefits and overtime;
- Mobilization & demobilization of contractor items;
- Non-manual labor (general foreman, superintendent, project manager, etc.);
- Indirect manual labor;
- Small tools;
- Consumables;
- Ownership and operational costs of construction equipment (inclusive of fuel);



- Health, safety and environmental requirements;
- Site supervision and administration;
- Contractor temporary site facilities;
- Overhead and profit (capped at 15%).

All lifting equipment including construction cranes, boom trucks, scissor lifts and manlifts are excluded from the crew rate build-up as Osisko will be adopting a self-perform execution strategy and will manage all lifting equipment during construction. These costs were estimated by Osisko and reported as indirect costs.

Contractor fees overhead and profit in the labour rate build-up will be capped at 15% as Osisko will adapt an open book construction strategy with potential contractors which they have used to their benefit recently.

The balance of construction equipment is included and will be developed and assigned by specific crew discipline. Hourly equipment costs include the material portion (depreciation, interest, cost of repair and maintenance, insurance permits and taxes) and operating portion (fuel, lubricants and filters). Sources for rates include the yearly Québec government publication titled "Taux de Location de Machinerie Lourde", used by the Ministry of Transport for civil contracts related to public works, roads and highways, contractor pricing and/or pricing received by crane suppliers. The cost of the operator is excluded from the hourly operating cost and included in the crew mix.

It is assumed that 100% of personnel reside beyond 120 km from site for the mine sites and that workers will be accommodated within the temporary construction camp, thereby eliminating the room & board allowance within the labour rate buildup.

Tailings Filtration and Past Backfill Plant (Area 665)

The tailings filtration and paste backfill plant capital costs were estimated by WSP. Plant 3D model, 2D drawings and P&IDs were developed for capital costs estimation with engineering design for all disciplines to define material take-offs, including manpower efforts. Major equipment specification sheets were prepared to obtain suppliers budgetary pricing. The total capital cost of the plant is estimated to be \$76.1M, as summarized in Table 21-9. Earthwork costs include only the rock excavation underneath buildings; most of the earthwork costs for area 665 is accounted for in site infrastructure area 505.



Table 21-9: Tailings filtration and paste backfill plant pre-production capital costs

Description	Total cost (\$M)	CAPEX (%)
Earthworks	0.08	0.1
Concrete	13.2	17.4
Structure	21.6	28.4
Architectural	7.6	9.9
Mechanical process equipment	18.6	24.4
Mechanical building utilities	3.1	4.1
Piping	3.7	4.9
Electricity, automation, and instrumentation	8.2	10.7
Tools	0.04	0.05
Total	76.1	100.0

21.1.3.1.8 Waste, Water and Tailings Management (Area 800)

The following items excluding the Water Treatment plant ("WTP") were estimated by WSP and Golder, based on unit costs obtained by Osisko from independent contractors:

- The tailings management facility earthworks and its related contact water ponds (Pond TMF#1 and Pond TMF#2) and ditches for phase 1;
- The overburden stockpile site preparation and the construction of the related ditches and pond (Pond J).

The estimation does not include indirect costs.¹

According to the contractors' estimates, the unit costs used for the cost estimate include equipment, material production and haulage, as well as manpower and fuel consumption. Water management expenses during earthworks are covered by the indirect cost estimates in Section 21.1.3.1.9.

The pre-production capital costs for the TMF and the overburden stockpile include:

- Ponds B, C, C2, J, U, TMF#1 and TMF#2;
- Overburden stockpile preparation;
- Overburden contact water collection ditches;
- Construction of diversion ditches;
- TMF site preparation, drainage system, surrounding access road and associated surrounding ditches for phase 1.



The cost associated to the WTP were estimated by GCM. Water treatment plant design was based on Project assumptions taken before October 1st, 2022. Most of the process equipment will be installed in an existing warehouse annexed to the ammonia water treatment plant WTP except the thickener that treats underground water and the new moving bed bioreactor ("MBBR"). The plant layout and equipment list have been used to detail a material take-off list for each discipline. It has been considered that no loads can be transferred to the building, so piping and cables are all supported by trays. GCM's scope was limited to the foundation for the equipment's concrete base, structural steel for support and railings, process equipment, piping, and electrical/instrumentation services that are inside the WTP footprint. Bids were obtained for the major equipment. Costs were evaluated from similar projects and in-house data.

Table 21-10: Waste, water and tailings management pre-production capital costs

Description	Total cost (\$M)	CAPEX (%)
Waste, water and tailings management - general	2.25	3.2
Surface tailings management facility	16.93	24.4
Waste rock stockpile	0.79	1.1
Reclaim water pumping station	0.02	0.2
Water treatment plant - general	20.03	28.8
Site drainage and settling ponds	29.30	42.2
Total	69.49	100.0

21.1.3.1.9 Indirect Costs (Area 900)

Indirect costs for the Windfall Project include all costs needed to carry out the engineering, procurement, and construction management services. These costs were calculated by Osisko's estimating group. The main costs in this category are Engineering, Procurement and Construction Management (EPCM) services, temporary facilities, third-party services, spare parts, freight, and customs. Note that most of the detailed engineering costs are not included and are considered a long lead expense.

For the Project indirect costs included within the pre-production capital cost estimate, an itemized list of elements has been used to generate factored estimates. The following have been covered:

- EPCM;
- Costs associated with permitting and public consultations;
- Construction temporary facilities erection and operation;
- Land and ocean freight for process and major electrical equipment;



- Pre-operational verifications;
- Commissioning support;
- Vendor representatives;
- Capital spares;
- One-year operating spares;
- Commissioning spares;
- First fills;
- Waste disposal;
- Sanitary blocks;
- Construction temporary power.

The indirect costs were calculated using various sources of information, including the construction execution plan and information provided by Osisko. Indirect costs, excluding Owner's costs (WBS 000) total \$61.3M.

21.1.3.2 Contingency (Area 999)

Contingency is an allowance included in the preproduction capital cost estimate that is expected to be spent to cover the known but undefined items within the scope of the estimate. These can arise due to currently undefined items of work or equipment, or to uncertainty in the estimated quantities and unit prices for labour, equipment and materials. Contingency does not cover scope changes, project exclusions or project risk reserve costs.

The preproduction cost contingency was calculated for the Project using a Monte Carlo probabilistic approach based on execution philosophy, historic data, level of project definition and advancement of engineering as well as contributions from the various firms according to their scope of work.

Capitalized mining operating costs were excluded from the contingency calculation. Table 21-11 and Figure 21-3 show the distribution of possible preproduction capital expenditures based on Monte Carlo simulations performed.



Table 21-11: Monte Carlo contingency simulation results

Percentile of Simulation Results (P _x %)	Simulated Contingency (\$M)	Simulated Pre-production Capital Cost (\$M)	Contingency (%) ¹
5	8.4	747.5	1.7%
10	17.4	756.5	3.6%
15	23.4	762.5	4.9%
20	28.3	767.4	5.9%
25	32.5	771.6	6.7%
30	36.1	775.2	7.5%
35	39.8	778.9	8.2%
40	42.9	782.0	8.9%
45	46.2	785.3	9.6%
50	49.5	788.6	10.2%
55	53.0	792.1	11.0%
60	56.4	795.5	11.7%
65	59.8	798.9	12.4%
70	63.5	802.6	13.1%
75	67.4	806.5	13.9%
80	71.7	810.8	14.8%
85	76.6	815.7	15.9%
90	83.2	822.3	17.2%
95	92.8	831.9	19.2%

1- Contingency percentage based on pre-production capital costs of \$483.6 M not including owner's costs, mining development, and designated infrastructure costs.

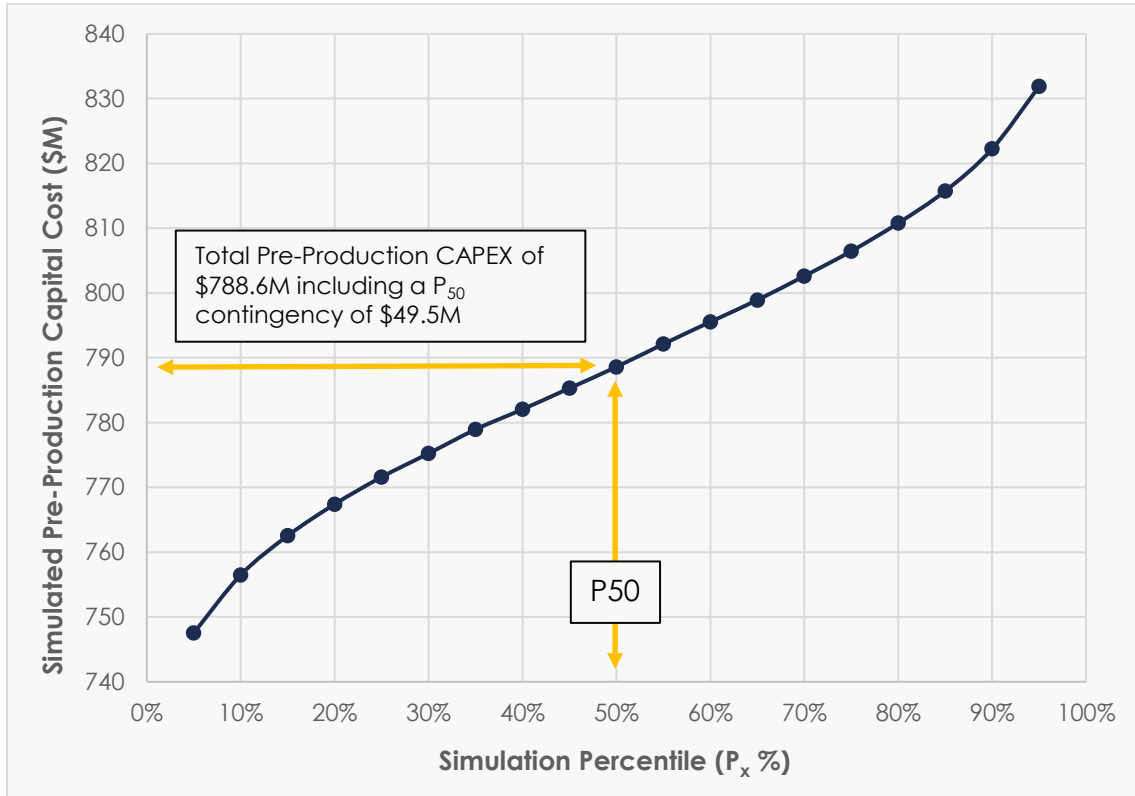

Figure 21-3: Preproduction capital cost estimate Monte Carlo Simulation Results

Osisko selected a contingency amount of \$49.5M, which is the P₅₀ of the Monte-Carlo simulation. This represents approximately 10.2% of the pre-production capital costs (\$483.6 M) less Owner's costs (Area 000), mining development (Ares 200), and designated infrastructure costs totalling \$305.0M as these cost areas were already considered to have some contingency embedded in them. On an overall project cost basis including all direct and indirect costs, the contingency represents 6.3% of the pre-production costs (\$788.6M).

It is expected that to meet the budget for the Project, sufficiently developed engineering, adequate project management and tight construction cost controls will be required.

21.1.4 Sustaining Capital Costs

The sustaining capital costs incurred over the 22 years of production (Q4 2025 to 2047) from the Windfall mine are estimated to total \$652.3M of project-related capital expenditures, including site reclamation and closure costs and salvage value. The breakdown of LOM sustaining capital expenditures by area is provided in Table 21-12 and Figure 21-4, while a detailed sustaining capital



schedule is provided in Table 21-13. The sustaining capital costs do not include a contingency, as the designs and costing were conservative.

Table 21-12: Sustaining capital costs summary

Area	Description	Sustaining capital cost (\$M)	CAPEX (%)
000	General administration (Owner's costs)	1.3	0.2
200	Underground mine	556.7	85.3
300	Mine surface facilities	3.7	0.6
800	Waste, water and tailings management	26.0	4.0
	Total	587.6	90.1
	Site reclamation and closure	83.3	12.8
	Salvage value	(18.7)	(2.9)
	Total - Forecast to spend	652.3	100.0

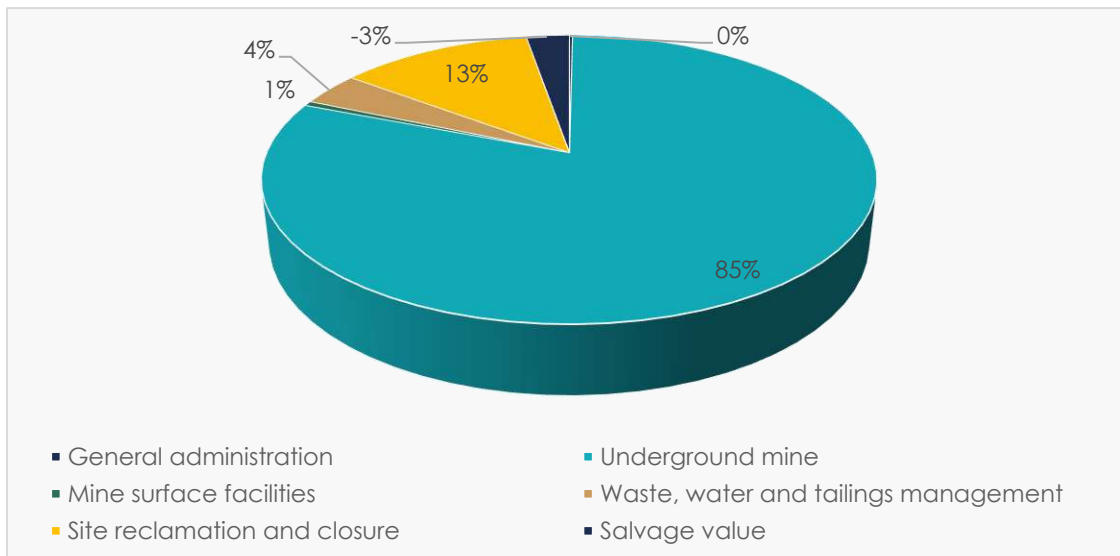

Figure 21-4: Project sustaining capital cost summary



Table 21-13: Sustaining capital costs breakdown

Year		2025	2026	2027	2028	2029	2030	2031	2032	2033	2034	2035	2036	2037	2038	2039	2040	2041	2042	2043	2044	2045	2046	2047	Total cost (\$M)	CAPEX (%)	
Area	Description	Sustaining Capital Cost (\$M)																									
000	General administration	-	-	0.3	0.3	0.2	-	-	0.3	0.3	0.1	-	-	-	-	-	-	-	-	-	-	-	-	-	-	1.3	0.2
200	Underground mine	8.7	89.9	64.0	69.2	47.1	74.3	54.5	64.7	50.7	27.9	5.6	-	-	-	-	-	-	-	-	-	-	-	-	-	556.7	85.3
300	Mine surface facilities	-	1.7	1.5	-	-	-	-	0.4	-	-	-	-	-	-	-	-	-	-	-	-	-	-	-	-	3.7	0.6
800	Waste, water and tailings management	-	-	-	-	10.2	9.0	-	-	6.8	-	-	-	-	-	-	-	-	-	-	-	-	-	-	-	26.0	4.0
	Total	8.7	91.6	65.7	69.5	57.5	83.2	54.5	65.5	57.8	28.0	5.6	0.0	0.0	0.0	0.0	0.0	0.0	0.0	0.0	0.0	0.0	0.0	0.0	0.0	587.6	90.1
	Site reclamation and closure	-	-	-	-	-	11.5	-	-	5.4	-	-	22.9	22.9	0.1	0.1	0.1	0.1	20.0	0.1	0.1	0.1	0.1	0.1	0.2	83.3	12.8
	Salvage value	-	-	-	-	-	-	-	-	-	-	-	-	(6.4)	-	-	-	-	(12.3)	-	-	-	-	-	-	(18.7)	(2.9)
	Total	8.7	91.6	65.7	69.5	57.5	94.8	54.5	65.5	63.2	28.0	5.6	22.9	16.4	0.1	0.1	0.1	0.1	7.7	0.1	0.1	0.1	0.1	0.1	0.2	652.3	100.0



21.1.4.1 General administration (Area 000)

Sustaining costs for general administration include the purchase of mobile equipment such as pick-up trucks for a total amount of \$1.3M over the life of mine.

21.1.4.2 Underground Mining (Area 200)

The total underground sustaining capital is \$556.7M for the Windfall Project and costs are broken down by activity in Table 21-14.

Sustaining capital costs consider the following:

- Capitalized underground excavations completed after pre-production;
- Underground construction;
- Equipment and mine services networks (general constructions, ventilation, water management, electrical, communication, backfill);
- Contractor vertical development; and
- Mobile equipment.

Although limited contingency was applied as a flat factor, contingency has been included by using conservative equipment refurbishment values for rebuilds and replaced at a higher frequency than observed at other Canadian operations (to improve equipment availability). Mining costs were compared between an owner-operated model and a contractor-operated model. The owner-operated costs were within the range of costs provided by the contractors.

Table 21-14: Underground sustaining capital costs

Description	Total cost (\$M)	CAPEX (%)
Mine development	237.4	42.6
Underground infrastructures	54.3	9.7
Main ventilation	14.4	2.6
Underground water management	4.1	0.7
Underground electrical substation	3.0	0.5
Underground mine mobile equipment	219.8	39.5
Total	556.7	100.0



21.1.4.3 Mine Surface Facilities (Area 300)

WSP added costs in sustaining capital for the Lynx portal construction with its mine services and for the exhaust raises VR-1 and VR-4 civil and electrical installation.

Table 21-15: Mining surface infrastructure sustaining capital costs

Description	Total cost (\$M)	CAPEX (%)
Lynx portal	1.5	41.3
Air intake	0.1	2.7
Air exhaust	2.0	56.0
Total	3.7	100.0

21.1.4.4 Waste, Water and Tailings Management (Area 800)

The sustaining capital costs for the surface water management and waste rock management include:

- The construction of ponds F and D2 in 2029, including their afferent collection ditches, pump stations and piping;
- The waste rock stockpile expansion in 2029.

The sustaining capital costs for the surface TMF include:

- The TMF Phase 2 expansion in 2030 and Phase 3 expansion in 2033;
- The drainage system, surrounding access road and associated surrounding ditches for the TMF expansions.

The estimated sustaining capital costs are based on unit costs obtained by Osisko from independent contractors. According to the contractors estimates, the unit costs used for the cost estimate include equipment, material production and haulage, as well as manpower and fuel consumption. Water management expenses during earthworks are covered by the indirect cost estimates in Section 21.3.11. The estimation does not include indirect costs.



Table 21-16: Waste, Water and Tailings management pre-production capital costs

Description	Total cost (\$M)	CAPEX (%)
Waste, water and tailings management - general	1.36	5.2
Surface tailings management facility	14.38	55.3
Waste rock stockpile	4.59	17.7
Site drainage and settling ponds	5.66	21.8
Total	25.99	100.0

21.1.4.5 Rehabilitation and Mine Closure Capital Costs

Reclamation and closure costs for the site were estimated by WSP at a total of \$83.3M. This estimate includes the reclamation, dismantling and removal of proposed buildings and foundations, restoration of the surface footprint of the infrastructure, restoration of the waste rock stockpiles, restoration of the tailings storage facility, and restoration of the water storage ponds.

Progressive reclamation for Windfall site will start in 2030, during the TMF Phase 2 expansion and in 2033 during TMF Phase 3 expansion. Reclamation for the Project will start in 2036, after the end of the mine production (2035). The remaining rehabilitation activities are expected to be performed in Year 17 (2042). All access will be ultimately blocked in Year 22 (2047). Table 21-17 provides a breakdown of the costs associated with site rehabilitation and closure. The costs include engineering costs and a 18% contingency.

The aforementioned cost does not include the contingency required by the *Ministry of Energy and Natural Resources* ("MERN"), and therefore may differ from the financial guarantee required by the Ministry.



Table 21-17: Site rehabilitation and closure capital costs

Description	Total cost (\$M)	CAPEX (%)
Mine site securing	16.3	19.5
Camp sector dismantling	0.0	0.0
Portal sector dismantling	0.3	0.4
Building, storage area and roads restoration	3.7	4.4
Overburden piles restoration	0.2	0.2
Ore material piles restoration	0.0	0.0
Waste piles restoration	7.5	9.0
Tailings management restoration	24.9	29.9
Pond restoration	10.2	12.2
Soils characterization program	0.5	0.6
Indirect costs	8.3	10.0
Contingency	11.5	13.8
Total	83.3	100.0

21.1.4.6 Salvage Value

Salvage value was estimated at \$18.7M. The following items were considered:

- Camp complex (\$6.4M);
- Major process equipment (\$11.5M);
- Steel value (\$0.8M).

21.2 Operating Costs

21.2.1 Summary

The average operating cost over the 10-year mine life is estimated to be \$176.67/t milled or \$726/oz¹ (CAD). The total amount of tonnes used to calculate the cost per tonnes milled is 12,079,161 Mt. This value is calculated based on the start of commercial production period in Q4 2025.

¹ Total operating cost divided by total payable gold oz.



Table 21-18, below, provides the breakdown of the projected operating costs for the Windfall Project.

Table 21-18: Windfall Project operating cost summary

Cost area	LOM (\$M)	Average annual cost (\$M)	Average (\$/tonne milled)	Average LOM (\$/oz)	OPEX (%)
Mining	993.0	99.3	82.21	337.7	46.5
Process plant including filtration	492	49.2	40.76	167.4	23.1
Waste and water management	76	7.6	6.30	25.9	3.6
General and administration	396	39.6	32.81	134.8	18.6
Electrical transmission line lease cost	176	17.6	14.59	59.9	8.3
Total	2,134.0	213.4	176.67	725.6	100.0

21.2.2 Basis of Operating Cost Estimate

The operating cost estimate was based on Q4 2022 assumptions. The estimate has an accuracy of $\pm 15\%$. All operating cost estimates are in CAD. All the areas are generally itemized in detail. The operating cost estimate is based on testwork, budgetary quotations, and in-house data and experience from similar projects and operations. Salaries, overhead and bonuses were provided by Osisko's Human Resources Group.

The operating cost estimate is based on the mine schedule indicative tonnage per time period that was produced by Entech on November 3, 2022, and inclusive of all site costs. Costs up to and including C4 commissioning are excluded from operating costs and are included in the capital cost estimate.

Assumptions and Exclusions

The following items were assumed:

- All equipment and materials will be new;
- Salaries and benefits were provided by Osisko. The labour rate build-up will be based on the statutory laws governing benefits to workers that were in effect at the time of the estimate;
- No cost of commissioning assistance post C4 certificate issuance is included in the operating cost estimate;
- Budgetary prices, including delivery to site, were obtained for all reagents, based on annual consumption;
- Freight estimates are based on vendor-supplied freight quotations or in-house data. Freight for reagents is included in the price of those commodities. Freight for steel consumables is



included in the price of that material. Freight for spare parts is calculated as a percentage of equipment cost expected to be used annually;

- No cost escalation (or de-escalation) is assumed;
- Service fees to use the future electrical transmission line connecting the Windfall site to the HQ network are based on term sheet with Miyuukaa, a wholly-owned corporation of the CFNW (Osisko Mining, 2022).

The following items were specifically excluded from the operating cost estimate, unless identified by the Owner's team and included in the Owner's costs:

- Cost of financing and interest;
- Pre-start-up operations and maintenance training;
- Corporate General and Administration (G&A) costs;
- Transport and handling of doré (included in the financial analysis).

Estimate Responsibilities

The overall operating cost estimate combined inputs from a number of sources, including BBA, Entech, WSP, GCM and Osisko as summarized in Table 21-19.

Table 21-19: OPEX estimate responsibilities

Cost area	Responsible entity
Mining	Entech
Process plant, including tailings filtration and Paste Backfill	BBA and WSP
Waste, water management and environment	WSP, GCM, and Osisko
General and administration	BBA and Osisko
Electrical transmission line service fees	BBA and Osisko

General Unit Rates

General rates used in the operating cost estimate are summarized in Table 21-20.



Table 21-20: General rate and unit cost assumptions

Parameter	Unit	Value
Average daily LOM tonnage ²	tpd	3,400
Years of operations	year	10
LOM production	M tonnes	12.1
Average mill feed gold grade	Au g/t	8.06
Average mill feed silver grade	Ag g/t	4.18
Average annual gold produced	Au Koz	294.1
Average annual silver produced	Ag Koz	136.6
Electrical Power	\$/kWh	0.055
Propane	\$/L	0.62
Coloured diesel	\$/L	1.18
Clear diesel	\$/L	1.44

21.2.3 Mining

21.2.3.1 Underground Mining

Entech provided estimates for all underground mine operating costs. The total underground mine operating cost is \$993.0M for Windfall. The operating unit costs were calculated over the total ore material mined from development and production, including the ore stockpiled at surface before construction. The unit cost is \$82.21/t milled for Windfall.

Total mining operating costs consider the following:

- The backfill OPEX excludes the maintenance and operation of the paste backfill network on surface;
- The backfill OPEX includes the underground installation and maintenance of the paste backfill distribution, as well as paste backfill binder costs; and
- No contingency has been applied to the mining costs, except for the grade control estimate where limited contingency has been applied.

Mining labour cost excludes food and lodging allowances, which are included in the General & Administration operating costs (Section 21.2.6).

Table 21-21 summarizes the underground operating costs and provides a breakdown per item.

² Calculation excludes non-optimized last year of production (2035).



Table 21-21: Underground operating costs

Operating costs		Total LOM cost	Average LOM cost	OPEX
Activity	Sub-activity	(\$M)	(\$/t milled)	(%)
Grade control	Definition drilling & sampling	71.1	5.89	7.2
Mine development	Mine development	249.0	20.62	25.1
Production	Production - Raise, drilling & blasting	173.0	14.32	17.4
	Production - Mucking & hauling	161.1	13.34	16.2
	Production - Backfill	46.9	3.89	4.7
Services	UG Services	155.4	12.87	15.6
	Maintenance	84.9	7.03	8.5
	Energy cost	51.6	4.27	5.2
	Total	993.0	82.21	100.0

Table 21-22 presents a more detailed overview of the underground operating costs. It provides a breakdown per item and per year.



Table 21-22: Overview of the underground operating costs per year

Operating Costs - Mining		2025	2026	2027	2028	2029	2030	2031	2032	2033	2034	2035	Total cost
Activity	Sub-activity						(\$M)						(\$M)
Grade control	Definition drilling & sampling	0.9	6.7	7.5	6.6	7.7	7.8	7.0	8.4	7.5	7.7	3.4	71.1
Mine development	Mine development	4.3	27.3	31.5	27.7	28.5	28.0	27.9	27.2	25.0	17.5	4.2	249.0
Production	Production - Raise, drilling & blasting	2.2	16.1	17.7	16.5	19.0	18.7	17.8	19.1	19.1	18.8	8.0	173.0
	Production - Mucking & hauling	2.1	17.9	18.6	17.3	17.4	17.4	17.4	17.5	16.5	14.4	4.7	161.1
	Production - Backfill	0.5	4.4	4.0	4.3	5.0	4.8	4.2	5.6	5.3	5.8	2.9	46.9
Services	UG Services	2.6	16.3	16.6	16.2	16.5	16.7	16.4	16.4	15.7	14.1	8.0	155.4
	Maintenance	1.3	9.1	9.0	9.1	9.3	9.3	9.2	9.2	9.0	7.3	3.1	84.9
	Energy cost	0.6	5.1	5.5	5.3	5.5	5.6	5.6	5.7	5.5	5.0	2.0	51.6
	Total	14.5	102.9	110.3	102.9	108.8	108.2	105.4	109.1	103.7	90.7	36.4	993.0



21.2.3.1.1 Cost Estimate - General

Direct costs, such as consumables and licensing fees, were calculated from first principles, where total quantities of each consumable type were determined and costed based on recent supplier quotes.

Labour requirements were determined based on equipment operator needs and support positions quantified based on agreement between Entech and Osisko. Labour costs were provided by Osisko as described in Section 21.2.2.

Mobile equipment maintenance costs were based on preventative maintenance schedules and costs provided by equipment manufacturers.

Diesel fuel costs were based on fuel consumption rates as provided by equipment manufacturers, and diesel fuel costs as provided by Osisko.

21.2.3.1.2 Cost Estimate - Grade Control

Grade control costs include definition drilling to a 12.5 m spacing, operating development test holes, muck samples and channel samples, as well as stope muck samples. Costs were provided by the Osisko geology team based on current and anticipated contractor rates, while sampling frequencies are based on current knowledge of the orebody.

21.2.3.1.3 Cost Estimate - Mine Development

Mine development costs include direct costs, labour and equipment maintenance. These costs were calculated as described in Section 21.2.3.1.1. The average costs during the Feasibility mine plan are approximately \$4,700 per lateral metre of Capital development, and \$3,600 per lateral metre of Operating development.

21.2.3.1.4 Cost Estimate - Production

Production costs include direct costs, labour, diesel fuel and equipment maintenance. These costs were calculated as described in Section 21.2.3.1.1. The average cost during the Feasibility mine plan is approximately \$73 per stope tonne.

21.2.3.1.5 Cost Estimate - Services

Mine services costs include direct costs, labour, diesel fuel, and equipment maintenance for infrastructure, ventilation, pumping, electrical and mobile equipment. Maintenance costs for fixed



equipment is based on supplier provided data plus an allowance for additional consumables. All other costs were calculated as described in Section 21.2.3.1.1.

21.2.3.1.6 Personnel

A peak of 372 workers is required for the underground mine, as described in Section 16.11. Table 21-33 contains the mining personnel required for each department.

21.2.4 Process Plant

This section contains the operating costs for the process plant and tailings filtration and paste backfill plant. The annual processing operating costs was estimated to be or \$49.2M or \$40.76 per tonne milled.

21.2.4.1 Process Plant

BBA estimated the process plant operating costs over the LOM. The annual operating cost was estimated to be \$41.6M or \$34.48 per tonne milled. These costs do not include the operating costs for the paste backfill or tailings filtration (see Section 21.2.4.2).

The steady-state operating costs include reagents, equipment consumables and maintenance, grinding media, personnel (including contractors), electrical power, propane consumption, as well as external laboratory assays and an allowance for special projects. The process consumables include grinding media as well as mill and crusher liners. A breakdown of the steady-state process plant operating costs, without contingency, is presented in Table 21-23.

Table 21-23: Process plant operating costs

Cost area	Average annual cost (\$M)	Cost per tonne milled (\$/t)	OPEX (%)
Reagents	10.6	8.80	25.5
Equipment consumables and maintenance	8.0	6.59	19.1
Grinding media	6.2	5.16	15.0
Personnel	9.4	7.80	22.6
Utilities	6.4	5.29	15.3
Miscellaneous	1.0	0.84	2.4
Total	41.6	34.48	100.0



21.2.4.1.1 Reagents

Numerous reagents are required for the Windfall process flowsheet to operate the carbon-in-pulp ("CIP"), elution and cyanide destruction circuits as well as the thickener. The reagent consumptions were estimated based on testwork results, industrial references and literature, and are presented in Chapter 17.

The annual reagents operating cost was estimated to be \$10.6M or \$8.80 per tonne milled. Cyanide alone accounts for 42.2% of the reagents costs, and an additional 14.5% is taken into account for liquid SO₂ and 14.4% for lead nitrate.

A summary of the average annual cost for each of the reagents is presented in Table 21-24.

Table 21-24: Reagents – Application and consumption

Cost area	Average annual cost (\$M)	Cost per tonne milled (\$/t)	OPEX (%)
Quick lime (Ca(OH) ₂)	1.0	0.81	9.2
Sodium cyanide (NaCN)	4.5	3.71	42.2
Activated carbon	0.4	0.29	3.3
Hydrochloric acid (HCl)	0.4	0.36	4.1
Sodium hydroxide (NaOH)	0.4	0.33	3.8
Flocculant - Pre-leach thickener	0.2	0.17	1.9
Leach aid	0.3	0.27	3.1
Anti-scalant	0.1	0.08	0.9
Liquid SO ₂	1.5	1.28	14.5
Lead nitrate	1.5	1.26	14.4
Copper sulfate (CuSO ₄ .5H ₂ O)	0.3	0.21	2.4
Refining fluxes	0.0	0.02	0.2
Total	10.6	8.80	100.0

21.2.4.1.2 Equipment Consumables and Maintenance

The replacement costs of major equipment consumables such as the SAG, ball mill and pebble crusher liners, the jaw crusher fixed and movable liners, screen panels and pump cell screens were calculated based on recommended change-out schedules, budgetary quotations, and using BBA's internal database. The total cost for these items was estimated to average \$8.0M per year or \$6.59 per tonne milled.



The general maintenance of the process plant equipment was calculated by applying fixed percentages to the indicated capital cost of a given area. The processing areas and percentages applied to the mechanical, electrical and instrumentation equipment, as well as the piping materials in the process plant.

21.2.4.1.3 Grinding Media

The grinding media consumption for the SAG and ball mills was estimated using benchmarking data for similar projects and adjusted using power calculations. The total cost for these items was estimated to average \$6.2M per year or \$5.16 per tonne milled. The average media consumption for both grinding applications is presented in Table 21-25.

Table 21-25: Estimated grinding media consumption

Area	Type	Size (mm)	Consumption (tpy)
SAG mill	Forged steel	127	935
Ball mill	Forged steel	50.8	1674

21.2.4.1.4 Personnel

A total of 61 workers is required in the process plant, including 37 salaried staff and 24 hourly workers. Table 21-26 and Table 21-27 present the salaried and the hourly manpower requirements, respectively, for the process plant. Electricians included in the site services operating costs area are shared to the process and filtration plant. The contractor and consultant costs for processing, including items such as special projects and research and development (“R&D”), were added to operation and maintenance personnel cost.

The annual operating cost for personnel and contractors was estimated to be \$9.4M or \$7.80 per tonne milled.

Table 21-26: Process plant salaried personnel

Position	No. of employees
Process Plant Director	1
Process Plant Production Superintendent	1
Surface Maintenance Superintendent	1
Reliability Engineer	1
Maintenance Supervisor	2



Position	No. of employees
Electrical Planner	2
Process Plant Planner	2
Senior Planner	1
Electrical IT/OT Designer	2
Electrical Supervisor	2
Instrumentation Technicians	6
Process Control Engineer	1
Process Control Programmer	2
Operation Supervisor	4
Chief Metallurgist	1
Metallurgist	2
Metallurgical Technician	4
Refiner	2
Total	37

Table 21-27: Process plant hourly personnel

Position	No. of employees
Crushing and Grinding	4
CIP-Elution Operator	4
Control Room Operator	4
Lab Operator	2
Industrial Mechanic	10
Total	24

21.2.4.1.5 Utilities

The electrical energy requirements for the process plant were derived from the equipment list in which expected motor sizes for all equipment and ancillaries have been provided. Each motorized item of equipment was assigned utilization, efficiency, and load factors to derive the data presented in Table 21-28.



Table 21-28: Process plant power demand by area

Area	Power demand (MW)
Process Plant fixed load	5.05
Plant variable load – Crushing	0.38
Plant variable load - Grinding	6.97
Network loss	0.31
Total	12.71

Network losses of 2.5% were accounted for in the total.

In addition to electricity, a propane consumption of 2.7 million litres per year (“MLpy”) is required to cover the process plant.

21.2.4.1.6 Miscellaneous

Miscellaneous area considers lab consumables, allowance for special projects and equipment rental for SO₂ and flocculant reagents systems. Rental systems costs were based on budgetary quotes from suppliers.

21.2.4.2 Tailings Filtration and Paste Backfill Plant

The tailings filtration and paste backfill plant operating costs have been calculated over the Windfall Project life of mine. On an average operating year, when both paste and dry stack are produced, the annual operating cost was estimated to be \$7.6M or \$6.28 per tonne milled (equivalent to tailings production).

The steady-state operating costs include reagents, energy, maintenance and wear parts, manpower, mobile equipment as well as consulting and laboratory fees. A breakdown of the average processing operating costs is presented in Table 21-29.



Table 21-29: Windfall filtration plant operating costs

Operating Cost Category	Annual Cost (\$M)	Cost per tonne milled (\$/t)	% of Total Opex (%)
Reagents	0.2	0.18	2.8
Energy	1.1	0.94	15.0
Maintenance and wear parts	0.9	0.74	11.7
Manpower	1.3	1.09	17.4
Mobile equipment	4.0	3.28	52.3
Consulting and laboratory	0.05	0.04	0.7
Total⁽¹⁾	7.6	6.28	100

⁽¹⁾ Total may not add up due to rounding.

21.2.4.2.1 Reagents

The reagents' cost category includes flocculant requirements for the tailings thickener and the clarifier. The cost of the binder used in paste backfill is included in the mining operating costs.

Flocculant consumption was calculated based on testwork results.

21.2.4.2.2 Energy

Estimate of electrical energy consumption for the tailings filtration plant was based on the electrical load list. Dry stack equipment power consumption is estimated at 2.5 MW, and paste production equipment is estimated at 2.7 MW.

21.2.4.2.3 Maintenance and Wear Parts

Maintenance costs for the tailings filtration plant were estimated based on the equipment capital cost. Included are the cost of capital spares recommended to have in inventory to allow for immediate replacements. An allowance is also made for maintenance supplies.

The filtration plant main wear items are the filter cloths. Filter cloths replacement costs were estimated based on the selected filter presses characteristics (size and number of cloths), cloth costs, and expected life. This information was obtained through the supplier.



21.2.4.2.4 Labour

The tailings filtration plant employs dedicated filter press operators (4), paste plant operators (4). Industrial mechanics and instrumentation technicians are shared between the mill and the filtration plant.

21.2.4.2.5 Mobile Equipment

Operation of the mobile equipment used for dry stack handling and deposition in the TSF is planned to be contracted out. These costs cover the equipment operation and manpower and were obtained from a contractor contacted by Osisko.

A trade-off is currently being performed between contracting the work vs company-based employees.

21.2.4.2.6 Consulting and Laboratory Fees

These costs include consumables for the filtration plant laboratory as well as costs associated with testwork required by external laboratories and consulting or engineering fees. They have been estimated based on similar projects.

21.2.5 Waste and Water Management

The waste and water management operating costs were based on feasibility study level estimates provided by GCM, WSP and Osisko. The average annual operating costs were determined to be \$7.6M per year or \$6.30 per tonne milled.

This area includes the following operating costs:

- Labour costs;
- Water treatment plant operations, maintenance and consumables;
- Waster management pumping costs (estimated at 250 kW);
- Environmental services group labour costs and associated expenses estimated such as:
 - Recycling and waste disposal fees;
 - Permitting costs;
 - Water royalties;
 - Equipment rental;
 - Sampling and analytical fees;



- Consulting and contract services;
- Environmental monitoring fees;
- Wet lands compensation fees in Y2 and Y3.

A breakdown of the steady-state costs, without contingency, is presented in Table 21-30.

Table 21-30: Waste and water management operating costs

Cost area	Average annual cost (\$M)	Cost per tonne milled (\$/t)	OPEX (%)
Labour	1.0	0.83	13.1
Water treatment plant operations	3.9	3.24	51.4
Water management	0.1	0.10	1.6
Environmental service fees	2.6	2.13	33.9
Total	7.6	6.30	100.0

The labour for the water treatment and environment area includes 11 employees in the environmental services group. Details are shown in Table 21-33.

21.2.5.1 Water Treatment Plant

Water treatment operation costs are calculated based on the mean annual flow rate, which will increase significantly at Year 5 of operation when the extension of the TSF will be built (Phase 2).

The water treatment operating costs excludes manpower costs and external laboratory analyses as they are considered in the labour and environmental service fees presented in Table 21-30.

The water treatment average annual operating costs is \$3.9M with a 3.24\$/t milled. Phases 1 and 2 annual operating costs are presented in Table 21-31.

Table 21-31: Water treatment operating costs

Operating Cost Category	Annual Cost (\$M)	
	2025(Q4)-2029 Phase 1	2030-2035 Phase 2
Reagents	2.6	3.0
Electricity	0.3	0.3
Propane	0.3	0.4
Maintenance and wear parts	0.4	0.4
Total	3.5	4.1

⁽¹⁾ Included in the general site manpower operation cost by Osisko.



21.2.5.1.1 Reagent

Reagent costs for water treatment are estimated at \$2.6M per year for Phase 1 and \$3.0M per year for Phase 2. These costs include all reagents required for water treatment. Together, caustic soda and ferric sulphate (coagulant) account for over 80% of the overall reagent costs for each phase.

Costs provided are calculated from reagent consumption, detailed in the water treatment plant Feasibility Technical Memorandum (GCM, 2022), and 2022 Q2-Q3 suppliers' estimated price per kilogram of reagent.

21.2.5.1.2 Energy

The estimate of electrical energy consumption for the water treatment plant was based on the electrical load list and the application of equipment-specific utilization factors.

The annual consumption is 4.9 GWh for Phase 1 and 5.3 GWh for Phase 2.

Propane is used as the energy source for process heating. The annual propane consumption is estimated to be 409,000 litres per year (409 KL/y) for Phase 1 and 626 KL/y for Phase 2.

21.2.5.1.3 Maintenance and Spare Parts

Annual maintenance for the water treatment plant is estimated based on the equipment capital cost and will total \$406,000 for both Phase 1 and Phase 2. It is recommended to have critical spare parts inventory for immediate replacement.

21.2.6 General and Administration

General and administrative ("G&A") costs are expenses not directly related to the production of goods and encompass items not included in the mining, processing, refining, and transportation costs of the Project. These costs were developed based on similar sized operations, BBA's in-house database and Osisko's past project experience. The costs do not include salaries and benefits for eighteen part-time personnel affiliated to corporate G&A, evaluated at \$3.1M per year.

The G&A area includes the following items:

- Site administration and management labour;
- Human Resources, Information Technology ("IT") and Health Services labour;
- Employee transport to site;
- Camp costs for employees and contractors (excluding corporate employees);



- Office furniture and supplies;
- Computer hardware and software costs/license fees, including annual licencing cost for the different IT/OT software and systems and advisory services required to develop and deploy a management operating system to support Windfall's integrated operation vision and strategy;
- Infrastructure electrical power and heating;
- Propane utilization for camp and kitchen;
- Health and safety supplies;
- Building insurance (including loss of production);
- Security, maintenance, cafeteria, laundry, snow removal and janitorial service contracts;
- Warehouse administration and supplies;
- Integrated operations, telecommunications and data service fees;
- Training;
- Municipal and school taxes;
- Off-site road maintenance costs;
- Surface mobile equipment operations including fuel consumptions.

The employee total for the overall General and Administration services is 48. The details can be seen in Table 21-33.

In general, the management and administrative staff will work 40 hours per week on day shift. Warehousing personnel will work a 12-hour shift per day to support the 24 hours of required daily operations.

On an annual basis, the G&A costs are estimated to be \$39.6M per year, or approximately \$396.3M over the mine's planned 10 years of operations. The G&A cost is \$32.81 per tonne milled (LOM).

The major costs broken down by item within the G&A category are shown in Table 21-32. The greatest cost within the G&A category is contract services (cafeteria, laundry, janitorial and security), representing approximately 24%, while mobile equipment operations and maintenance is the second-greatest cost accounting for approximately 17%. Labour represents approximately 17% of the G&A costs.



Table 21-32: General and administrative costs

Cost area	Average annual cost (\$M/year)	Cost per tonne milled (\$/t)	OPEX (%)
Labour	6.5	5.40	16.5
Management	0.8	0.69	2.1
Administration	0.4	0.32	1.0
IT & Communication	3.3	2.77	8.4
Health and safety	1.2	1.03	3.2
Technical services	0.2	0.16	0.5
Insurance	1.0	0.79	2.4
Electricity and heating	2.9	2.40	7.3
Building maintenance and rental fees	0.4	0.31	0.9
Cafeteria, laundry, janitorial and security services	9.5	7.86	24.0
Roads maintenance and snow removal	0.6	0.46	1.4
Mobile equipment operations & maintenance	6.9	5.71	17.4
Taxes (municipal and school)	5.9	4.91	15.0
Total	39.6	32.81	100.0

21.3 Site Personnel Summary – All Areas

A total facility workforce averaging 500 employees during full production years is estimated for the Windfall Project. A summary of labour averages in all areas is shown in Table 21-33. Contract employees are not included in the previously mentioned Project workforce total.



Table 21-33: Project site personnel (average) – All areas

Facility area	Role	Total
General & Administration	Management	2
	Administration and communication and IT	19
	Human resources and community relations	7
	Health and Safety	5
	Windfall site services	10
	Camp administration	5
	Subtotal	48
Underground mine	Operations	202
	Staff and supervision	25
	Technical services (Engineering and Geology)	70
	Maintenance	75
	Subtotal	372
Process plant (including Tailings Filtration and Laboratory)	Staff and supervision	35
	Operations	24
	Maintenance	10
	Subtotal	69
Waste and water management	Staff and supervision	5
	Operations	6
	Maintenance	0
	Subtotal	11
Windfall Project	Total	500



22. Economic Analysis

The economic/financial assessment of the Windfall Project for Osisko Mining was carried out using a discounted cash flow approach on a pre-tax and after-tax basis, based on consensus equity research long-term commodity price projections (November, 2022) in United States currency and cost estimates in Canadian currency. An exchange rate of 0.77 USD per 1.00 CAD was assumed to convert USD market price projections and particular components of the capital cost estimates into Canadian Dollars (“CAD”). No provision was made for the effects of inflation. Current Canadian tax regulations were applied to assess the corporate tax liabilities, while the most recent provincial regulations were applied to assess the Québec mining tax liabilities.

The internal rate of return (“IRR”) on total investment was calculated based on 100% equity financing, even though Osisko Mining may decide in the future to finance part of the Project with debt financing. The net present value (“NPV”) was calculated from the cash flow generated by the Project, based on a discount rate of 5%. The payback period, based on the undiscounted annual cash flow of the Project, is also indicated as a financial measure. Furthermore, a sensitivity analysis has been performed for the after-tax base case to assess the impact of variations in the project capital costs, USD:CAD exchange rate, price of gold, and operating costs.

The economic analysis presented in this section contains forward-looking information with regard to the mineral resource estimates, commodity prices, exchange rates, proposed mine production plan, projected recovery rates, operating costs, construction costs and project schedule. The results of the economic analysis are subject to a number of known and unknown risks, uncertainties and other factors that may cause actual results to differ materially from those presented here. The reader is cautioned that there is no certainty that the FS economics will be realized.

22.1 Assumptions and Basis

The economic analysis was performed using the following assumptions and basis:

- Project economics are based on a valuation date of April 1, 2024, which is the forecast date to potentially make a construction decision based on obtaining key permits;
- The Project Executive Schedule developed in Chapter 24, taking into consideration key project milestones;
- Commercial production start-up is scheduled to begin in the fourth quarter (“Q4”) of 2025. The first full year of production is therefore 2026. Operations are estimated to span a period of approximately 10 years ending in 2035;



- Final rehabilitation and closure activities will start progressively in 2030 (Year 5) and will be completed in 2047 (Year 22);
- The base case gold and silver prices are 1,600 USD/oz and 21.00 USD/oz, respectively;
- The long-term prices of gold and silver were estimated on the basis of discussions with experts, consensus analyst estimates and recently-published economic studies that were deemed to be credible (November, 2022). The forecasts used are meant to reflect the average metal price expectation over the life of the Project. No price inflation or escalation factors were taken into account. It is understood that commodity prices can be volatile and that there is the potential for deviation from the LOM forecasts;
- The United States to Canadian dollar exchange rate has been assumed to be 0.77 USD: 1.00 CAD over the life of mine (CAD:USD exchange rate of 1.30);
- All cost estimates are in constant Q4 2022 Canadian dollars with no inflation or escalation factors taken into account;
- All metal products are assumed sold in the same year they are produced;
- Cash flows are taken to occur at the beginning of each period;
- Sunk costs of \$6.7M and forecast long lead project development expenses of \$139.8M are not included in the economic analysis;
- Working capital cash outflows and inflows are included in the model;
- Class specific Capital Cost Allowance rates are used for the purpose of determining the allowable taxable income;
- Project revenue is derived from the sale of gold/silver doré into the international marketplace. No contractual arrangements for doré smelting or refining exist at this time.

This financial analysis was performed on both a pre-tax basis and after-tax basis with the assistance of an external tax consultant. The general assumptions used for this financial model, Feasibility mine plan tonnage and grade estimates are summarized in Table 22-1, and are outlined in Table 22-2.



Table 22-1: Financial model parameters

Description	Unit	Value
Long term gold price	USD/oz	1,600
Long term silver price	USD/oz	21.00
Exchange rate	USD:CAD	0.77
Discount rate	%	5
Mine life	year	10.0
Total mined and milled	Million tonnes	12.2
Gold grade	g/t	8.1
Silver grade	g/t	4.2
Process plant gold recovery	%	93.1%
Process plant silver recovery	%	83.7%
Underground mining operating cost	\$/t milled	82.21
Processing operating cost	\$/t milled	40.76
Waste and water management operating cost	\$/t milled	6.30
General and administration operating cost	\$/t milled	32.81
Electrical transmission line lease cost	\$/t milled	14.59
Royalties	% NSR	2.08%
Pre-production capital cost ¹	\$M	788.6
Sustaining capital cost	\$M	587.6
Reclamation and closure cost	\$M	83.3
Salvage Value	\$M	(18.7)

⁽¹⁾ Pre-production capital costs exclude sunk costs of \$6.7M and forecast long lead project development expenses of \$139.8M.

22.2 Gold and Silver Production

Over the life of mine, a total of 2.94 Moz of gold (payable) (average annual: 294,000 oz) and a total of 1.37 Moz of silver (payable) (average annual: 137,000 oz) will be produced.

Figure 22-1 provides a summary of the payable gold and silver production by year.



Figure 22-1: Payable gold and silver production (oz)

22.3 Pre-production and Sustaining Capital Costs

All capital costs (pre-production, sustaining, reclamation, closure and salvage value) for the Project have been distributed against the development schedule to support the economic cash flow model. Figure 22-2 presents the planned annual and cumulative LOM capital cost profile, excluding sunk costs and long lead development expenses totalling \$146.5M.

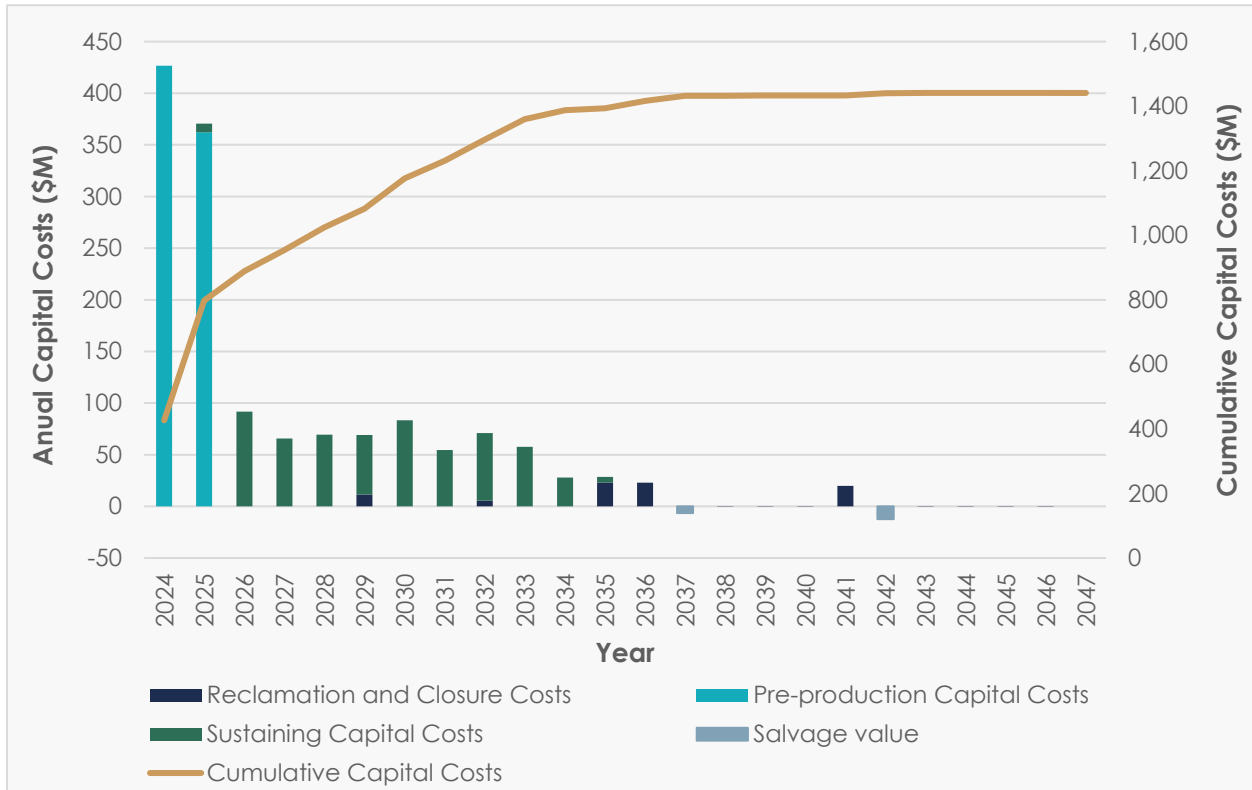

Figure 22-2: Overall Windfall Project capital cost profile

22.4 Royalties

Over the life of the Project, it is estimated that approximately \$127M in royalties will be paid based on the feasibility study mine plan and the various royalty agreements in place as described in Chapter 4. This results in an overall 2.1% NSR royalty for the Windfall deposit.

22.5 Taxation

22.5.1 Income and Mining Taxes

Osisko Mining compiled the tax calculations for the Windfall Project with assistance from third party taxation experts. The Canadian and Québec income and mining tax legislation currently in force was considered to determine the expected cash tax liabilities over the life of the Project. The



Windfall Project is subject to three levels of taxation: (i) federal income tax, (ii) provincial income tax; and (iii) provincial mining taxes.

The federal corporate tax rate considered is 15.0% while the provincial corporate tax rate is 11.5%.

From a provincial mining tax standpoint, the marginal tax rates applicable in Québec are 16%, 22% and 28% depending on the three profit margin categories ranging from 0% to 35%, 35% to 50% and above 50%. It has been considered that the 10% processing allowance rate associated with transformation of the mine product to a more advanced stage within the province would be applicable.

The tax calculations are underpinned by the following key assumptions:

- The Project is held 100% by a corporate entity and the after-tax analysis does not attempt to reflect any future changes in corporate structure or property ownership;
- Assumes 100% equity financing and therefore does not consider interest and financing expenses;
- Payments projected relating to NSR royalties are allowed as a deduction for federal and provincial income tax purposes, but are added back for provincial mining tax purposes; and
- Actual taxes payable will be affected by corporate activities, and current and future tax benefits, with respect to these activities have not been considered.

The combined effect on the Project of the three levels of taxation, including the elements described above, is an approximate cumulative effective tax rate of 30%, based on project net profits of \$2.43B. It is anticipated, based on the Project assumptions, that Osisko will pay approximately \$0.72B in income and mining tax payments over the life of the Project.

22.5.2 Carbon Taxes

Under current Canadian and Quebec legislation, industrial establishments that emit greater than 25,000 t CO₂eq per year are potentially subject to a carbon tax. An evaluation of the Windfall Project's annual carbon emissions was performed by a specialised consultant, and it was determined that carbon emissions created by blasting and the use of fixed equipment for all years during the life of mine were lower than the 25,000 t CO₂eq threshold requiring compensation. On this basis it was determined that the Windfall Project will not be subject to a carbon tax.



22.6 Financial Analysis Summary

A 5% discount rate was applied to the cash flow to derive the NPV for the Project on a pre-tax and after-tax basis. Cash flows have been discounted to April 1, 2024 under the assumption that the Project construction decision will be made, and major project financing would be completed at this time. The summary of the financial evaluation for the base case of the Project is presented in Table 22-2.

Table 22-2: Financial analysis summary (pre-tax and after-tax)

	Description	Unit	Base case
Pre-tax	Net present value (0% disc)	\$M	2,432.0
	Net present value (5% disc)	\$M	1,685.1
	Internal rate of return	%	40.1
	Payback Period After Start of Production	years	2.0
After-tax	Net present value (0% disc)	\$M	1,710.2
	Net present value (5% disc)	\$M	1,168.4
	Internal rate of return	%	33.8
	Payback Period After Start of Production	years	2.0

The pre-tax base case financial model resulted in an internal rate of return of 40.1% and an NPV of \$2,432.0M with a discount rate of 5%. The pre-tax payback period after start of production is 2.0 years. On an after-tax basis, the base case financial model resulted in an internal rate of return of 33.8% and an NPV of \$1,168.4M with a discount rate of 5%. The after-tax payback period after start of production is 2.0 years.

The summary of the Windfall Project discounted cash flow financial model (pre-tax and after-tax) is presented in Table 22-3.



Table 22-3: Windfall Project financial model summary

Year	-2	-1	1	2	3	4	5	6	7	8	9	10	11	12	13	14	15	16	17	18	19	20	21	22	Total		
	2024	2025	2026	2027	2028	2029	2030	2031	2032	2033	2034	2035	2036	2037	2038	2039	2040	2041	2042	2043	2044	2045	2046	2047			
Production Summary																											
Total tonnes mined (kt)	125	630	1,100	1,230	1,076	1,253	1,267	1,135	1,369	1,222	1,232	545	-	-	-	-	-	-	-	-	-	-	-	-	-	12,183	
Total tonnes milled (kt)		253	1,222	1,296	1,307	1,303	1,301	1,135	1,307	1,284	1,232	545	-	-	-	-	-	-	-	-	-	-	-	-	-	12,183	
Mill head grade Au (g/t)		9.58	8.39	9.59	8.58	8.01	7.25	7.37	8.53	7.81	7.16	6.79	-	-	-	-	-	-	-	-	-	-	-	-	-	8.06	
Mill head grade Ag (g/t)		3.52	4.19	4.30	3.94	4.95	4.65	4.04	4.46	3.82	3.73	3.42	-	-	-	-	-	-	-	-	-	-	-	-	-	4.18	
Gold production (koz)		73.2	305.8	374.1	335.3	310.7	279.8	249.3	335.2	300.3	266.4	112.4	-	-	-	-	-	-	-	-	-	-	-	-	-	2,942	
Silver production (koz)		23.8	138.3	150.1	138.6	176.6	161.8	119.6	158.9	132.1	124.9	48.8	-	-	-	-	-	-	-	-	-	-	-	-	-	1,373	
Payable gold (koz)		73.1	305.6	373.9	335.1	310.5	279.7	249.2	335.0	300.1	266.2	112.4	-	-	-	-	-	-	-	-	-	-	-	-	-	2,941	
Payable silver (koz)		23.7	137.6	149.4	137.9	175.7	161.0	119.0	158.1	131.4	124.2	48.5	-	-	-	-	-	-	-	-	-	-	-	-	-	1,367	
Revenue																											
Exchange rate (USD:CAD)	0.77	0.77	0.77	0.77	0.77	0.77	0.77	0.77	0.77	0.77	0.77	0.77	0.77	0.77	0.77	0.77	0.77	0.77	0.77	0.77	0.77	0.77	0.77	0.77	0.77	0.77	0.77
Gross revenue (\$M)		153	639.8	782.2	701.2	651.0	586.5	521.8	701.6	628.2	557.4	235.2	-	-	-	-	-	-	-	-	-	-	-	-	-	6,157.6	
Operating Expenditures																											
Mining (\$M)		14.5	102.9	110.3	102.9	108.8	108.2	105.4	109.1	103.7	90.7	36.4	-	-	-	-	-	-	-	-	-	-	-	-	-	993.0	
Processing (\$M)		6.4	48.9	51.9	51.4	51.3	51.3	48.9	51.4	51.1	50.3	29.5	-	-	-	-	-	-	-	-	-	-	-	-	-	492.3	
Tailings and Water Management (\$M)		1.0	7.3	7.7	8.0	7.0	7.6	7.6	7.6	7.6	7.6	7.2	-	-	-	-	-	-	-	-	-	-	-	-	-	76.1	
General & Administration (\$M)		6.4	40.3	39.9	40.1	39.8	40.0	39.7	39.7	39.1	38.4	32.9	-	-	-	-	-	-	-	-	-	-	-	-	-	396.3	
Electrical Transmission Line Lease (\$M)		0.7	26.7	24.4	23.5	17.3	16.9	16.3	15.6	14.9	14.9	4.9	-	-	-	-	-	-	-	-	-	-	-	-	-	176.2	
Operating Costs (\$M)		29.0	226.0	234.2	225.9	224.3	224.1	217.9	223.3	216.3	202.0	110.9	-	-	-	-	-	-	-	-	-	-	-	-	-	2,134.0	
Royalty payments (\$M)		3.1	14.3	16.3	14.2	13.3	11.8	10.4	14.1	12.8	11.9	5.0	-	-	-	-	-	-	-	-	-	-	-	-	-	127.4	
Capital Expenditures																											
Pre-production (\$M)	426.5	362.0	-	-	-	-	-	-	-	-	-	-	-	-	-	-	-	-	-	-	-	-	-	-	-	788.6	
Sustaining (\$M)		8.7	91.6	65.7	69.5	57.5	83.2	54.5	65.5	57.8	28.0	5.6	-	-	-	-	-	-	-	-	-	-	-	-	-	587.6	
Reclamation and closure (\$M)		-	-	-	-	-	11.5	-	-	5.4	-	-	22.9	22.9	0.1	0.1	0.1	0.1	20.0	0.1	0.1	0.1	0.1	0.1	0.2	83.3	
Salvage Value (\$M)		-	-	-	-	-	-	-	-	-	-	-	-	(6.4)	-	-	-	-	(12.3)	-	-	-	-	-	-	(18.7)	
Total Capital Costs (\$M)	426.5	370.7	91.6	65.7	69.5	57.5	94.8	54.5	65.5	63.2	28.0	5.6	22.9	16.4	0.1	0.1	0.1	0.1	7.7	0.1	0.1	0.1	0.1	0.1	0.2	1,440.8	
Changes in working capital (\$M) ⁽¹⁾	0.0	(2.2)	10.8	(0.6)	0.1	0.3	0.4	0.1	(0.9)	0.1	(0.3)	1.7	(9.5)	-	-	-	-	-	-	-	-	-	-	-	-	0.0	



Year	-2	-1	1	2	3	4	5	6	7	8	9	10	11	12	13	14	15	16	17	18	19	20	21	22	Total	
	2024	2025	2026	2027	2028	2029	2030	2031	2032	2033	2034	2035	2036	2037	2038	2039	2040	2041	2042	2043	2044	2045	2046	2047		
Pre-Tax Cash Flow																										
Pre-tax cash flow (\$M)	(426.5)	(252.8)	316.2	462.3	388.9	353.7	254.0	237.1	395.1	333.6	313.1	114.6	(32.4)	(16.4)	(0.1)	(0.1)	(0.1)	(0.1)	(7.7)	(0.1)	(0.1)	(0.1)	(0.1)	(0.1)	(0.2)	2,432.0
Cumulative Pre-Tax Cash Flow (\$M)	(426.5)	(679.4)	(363.2)	99.2	488.1	841.8	1,095.7	1,332.8	1,727.9	2,061.4	2,374.6	2,489.2	2,456.8	2,440.4	2,440.4	2,440.3	2,440.2	2,440.1	2,432.4	2,432.4	2,432.3	2,432.2	2,432.2	2,432.2	2,432.0	
Taxes and Duties⁽²⁾																										
Federal corporate income tax (\$M)	0.0	0.0	0.0	0.0	9.6	39.0	31.1	26.0	46.9	39.2	34.2	(10.2)	(9.7)	(6.9)	-	-	-	-	-	-	-	-	-	-	-	199.1
Provincial corporate income tax (\$M)	0.0	0.0	0.0	0.0	7.6	29.9	23.8	19.9	35.9	30.1	26.2	0.0	0.0	0.0	-	-	-	-	-	-	-	-	-	-	-	173.4
Québec mining duties (\$M)	0.0	2.0	15.0	21.7	38.5	42.2	30.8	27.4	65.9	52.4	45.8	7.6	0.0	0.0	-	-	-	-	-	-	-	-	-	-	-	349.2
Total Taxes and Duties (\$M)		2.0	15.0	21.7	55.7	111.0	85.7	73.3	148.7	121.7	106.1	(2.6)	(9.7)	(6.9)	-	-	-	-	-	-	-	-	-	-	-	721.8
After-Tax Cash Flow																										
After-Tax Cash flow (\$M)	(426.5)	(254.8)	301.2	440.7	333.2	242.7	168.3	163.7	246.4	211.9	207.0	117.2	(22.7)	(9.5)	(0.1)	(0.1)	(0.1)	(0.1)	(7.7)	(0.1)	(0.1)	(0.1)	(0.1)	(0.1)	(0.2)	1,710.2
Cumulative After-Tax Cash Flow (\$M)	(426.5)	(681.4)	(380.2)	60.5	393.7	636.3	804.6	968.3	1,214.7	1,426.6	1,633.6	1,750.8	1,728.1	1,718.6	1,718.5	1,718.5	1,718.4	1,718.3	1,710.6	1,710.5	1,710.5	1,710.4	1,710.4	1,710.2		

⁽¹⁾ A negative value indicates a decrease in working capital.

⁽²⁾ A negative value indicates a reimbursement of taxes and duties.



Figure 22-3 shows the cumulative cash flows for the Project projected for the life of the mine on a pre-tax and after-tax basis.

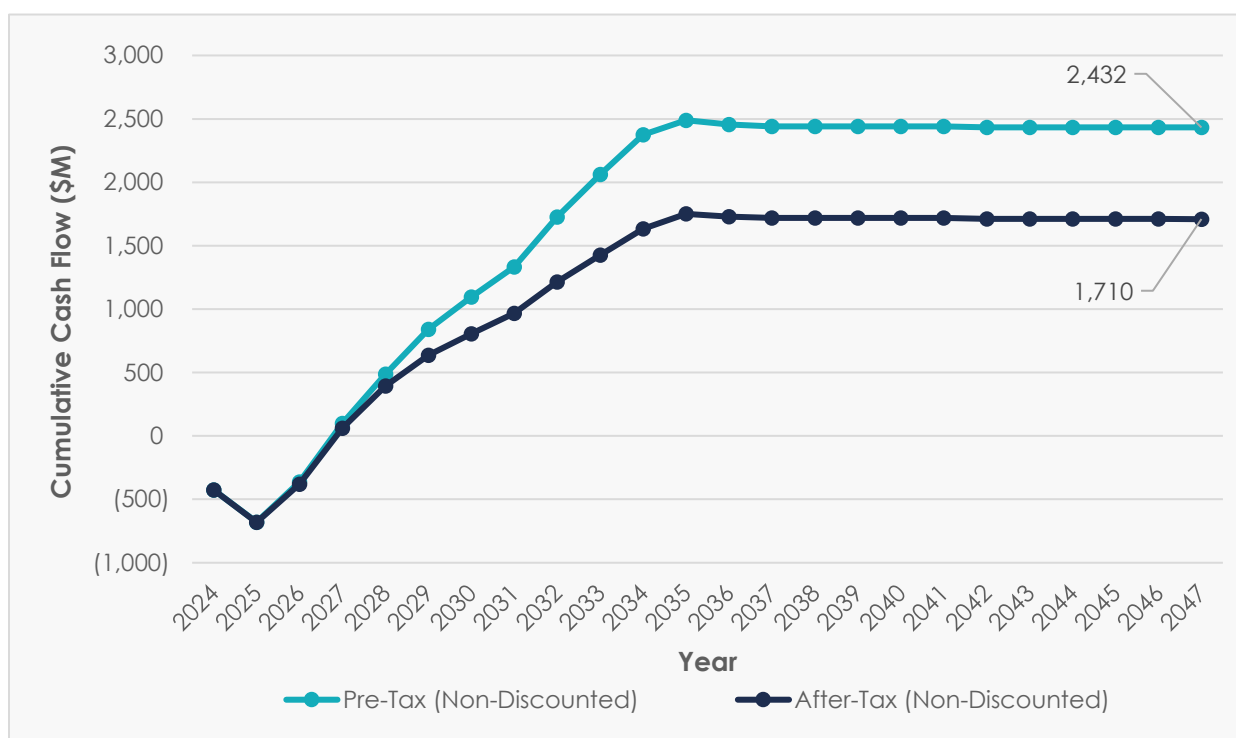

Figure 22-3: Life of mine cash flow projection (cumulative, pre-tax and after-tax)

22.7 Production Costs

A summary of the Project's production costs is provided in Table 22-4. All costs are in USD. Total cash costs are calculated per ounce on a payable basis using the costs of mining, processing, waste and water treatment, on-site G&A, electrical transmission line lease, refining and smelting, transport, and royalties. A credit for by-product silver revenues is then applied.

The LOM operating cash cost per ounce (Including by-product credits) is 587 USD/oz Au. The LOM cost all-in sustaining cost ("AISC"¹) per ounce is 758 USD/oz Au derived from the total cash costs plus sustaining capital, closure costs and salvage value. The operating margin over the LOM has been estimated to be 1,013 USD/oz Au based on a gold price of 1,600 USD/oz.

¹ All-in Sustaining Costs are presented as defined by the World Gold Council ("WGC") less Corporate G&A.



Table 22-4: Production cost summary

Description	Unit	LOM
Metal Payable		
Gold	Moz	2.9
Silver	Moz	1.4
Costs, Royalties and Credits		
Mining	USD M	763.9
Processing	USD M	378.7
Waste & water management	USD M	58.6
General & administration	USD M	304.9
Electrical transmission line lease costs	USD M	135.6
Refining and smelting	USD M	98.0
Royalties	USD M	15.4
By-product credit (Ag)	USD M	-28.7
Total operating cost (after credit)	USD M	1,726.3
AISC Costs and Profit Margins (per oz payable)		
Gold price	USD/oz	1,600.0
Cash cost (operating)	USD/oz	587.0
Sustaining and closure costs (net of salvage value)	USD M	501.7
Total costs (operating and sustaining)	USD M	2,228.0
AISC costs ⁽¹⁾	USD/oz	757.6
Operating margin	USD/oz	1,013.0

⁽¹⁾ As defined by the World Gold Council less corporate G&A costs.

22.8 Sensitivity Analysis

A financial sensitivity analysis was conducted on the base case after-tax cash flow NPV and IRR of the Project, using the following variables: capital costs, operating costs, USD:CAD exchange rate, price of gold and discount rate. The after-tax results for the Project's IRR and NPV based on the sensitivity analysis are summarized in Table 22-5 through Table 22-9.



Table 22-5: NPV sensitivity results (after-tax) for metal price and exchange rate variations

USD: CAD	Gold Price (USD/ounce)								
	1,200	1,300	1,400	1,500	1,600	1,700	1,800	1,900	2,000
0.90	1.9	234.8	440.3	605.7	762.5	913.0	1,061.6	1,208.4	1,353.4
0.85	166.7	398.5	577.9	744.9	904.5	1,062.0	1,217.4	1,370.6	1,520.6
0.80	351.3	546.1	725.0	895.1	1,062.4	1,227.4	1,389.8	1,549.1	1,707.8
0.77	448.8	640.4	821.1	996.1	1,168.4	1,338.7	1,504.8	1,670.2	1,835.4
0.70	676.0	872.0	1,063.5	1,251.9	1,436.4	1,618.4	1,800.1	1,979.1	2,157.2
0.65	857.8	1,064.1	1,267.0	1,465.0	1,660.9	1,856.1	2,048.2	2,240.0	2,431.8
0.60	1,064.9	1,284.5	1,498.4	1,710.2	1,921.0	2,128.8	2,336.6	2,544.3	2,751.8

Table 22-6: IRR sensitivity results (after-tax) for metal price and exchange rate variations

USD: CAD	Gold Price (USD/ounce)								
	1,200	1,300	1,400	1,500	1,600	1,700	1,800	1,900	2,000
0.90	5.1%	11.4%	16.5%	20.7%	24.5%	28.1%	31.5%	34.7%	37.8%
0.85	9.7%	15.4%	20.0%	24.1%	27.9%	31.5%	34.9%	38.2%	41.3%
0.80	14.2%	19.2%	23.6%	27.7%	31.5%	35.1%	38.6%	41.9%	45.1%
0.77	16.7%	21.5%	25.9%	30.0%	33.8%	37.5%	41.0%	44.4%	47.6%
0.70	22.4%	27.1%	31.5%	35.6%	39.6%	43.4%	46.9%	50.4%	53.8%
0.65	26.8%	31.5%	36.0%	40.2%	44.2%	48.0%	51.7%	55.4%	59.1%
0.60	31.6%	36.4%	40.9%	45.2%	49.3%	53.3%	57.3%	61.2%	65.0%



Table 22-7: NPV sensitivity results (after-tax) for operating and capital cost variations

CAPEX	OPEX						
	-30%	-20%	-10%	0%	10%	20%	30%
-30%	1,824.0	1,733.3	1,641.2	1,546.8	1,451.1	1,353.6	1,254.7
-20%	1,697.9	1,607.1	1,515.0	1,420.7	1,324.9	1,227.4	1,128.6
-10%	1,571.7	1,481.0	1,388.9	1,294.5	1,198.8	1,101.3	1,002.4
0%	1,445.6	1,354.8	1,262.7	1,168.4	1,072.6	975.1	876.3
10%	1,319.4	1,228.7	1,136.6	1,042.2	946.5	849.0	750.1
20%	1,193.2	1,102.5	1,010.4	916.1	820.3	722.8	624.0
30%	1,067.1	976.3	884.2	789.9	694.2	596.7	497.8

Table 22-8: IRR sensitivity results (after-tax) for operating and capital cost variations

CAPEX	OPEX						
	-30%	-20%	-10%	0%	10%	20%	30%
-30%	61.9%	59.6%	57.2%	54.7%	52.2%	49.5%	46.7%
-20%	52.8%	50.7%	48.6%	46.3%	44.0%	41.6%	39.0%
-10%	45.5%	43.6%	41.6%	39.5%	37.4%	35.1%	32.7%
0%	39.4%	37.6%	35.8%	33.8%	31.9%	29.7%	27.5%
10%	34.3%	32.6%	30.9%	29.0%	27.2%	25.2%	23.1%
20%	29.9%	28.3%	26.6%	24.9%	23.1%	21.2%	19.2%
30%	26.0%	24.5%	22.9%	21.2%	19.5%	17.7%	15.8%

Table 22-9: NPV sensitivity results (after-tax) for discount rate

	Discount Rate						
	0%	3%	5%	7%	9%	11%	13%
NPV (\$M)	2,432.	1,360.7	1,168.4	927.5	792.9	732.2	622.0

The graphical representations of the financial sensitivity analysis are depicted below in Figure 22-4 for the Project's NPV and Figure 22-5 for the Project's IRR.

The sensitivity analysis reveals that the gold price and the USD:CAD exchange rates have the most significant influence on the NPV compared to the other parameters, based on the range of values evaluated. After the gold price, NPV was impacted by variations in capital costs and operating costs.



For the Project's IRR, capital cost has the most significant influence followed by gold price variation and USD:CAD exchange rate and to a lesser extent by the operating cost.

Overall, the NPV and IRR of the Project are positive over the range of values used for the sensitivity analysis when analyzed individually.

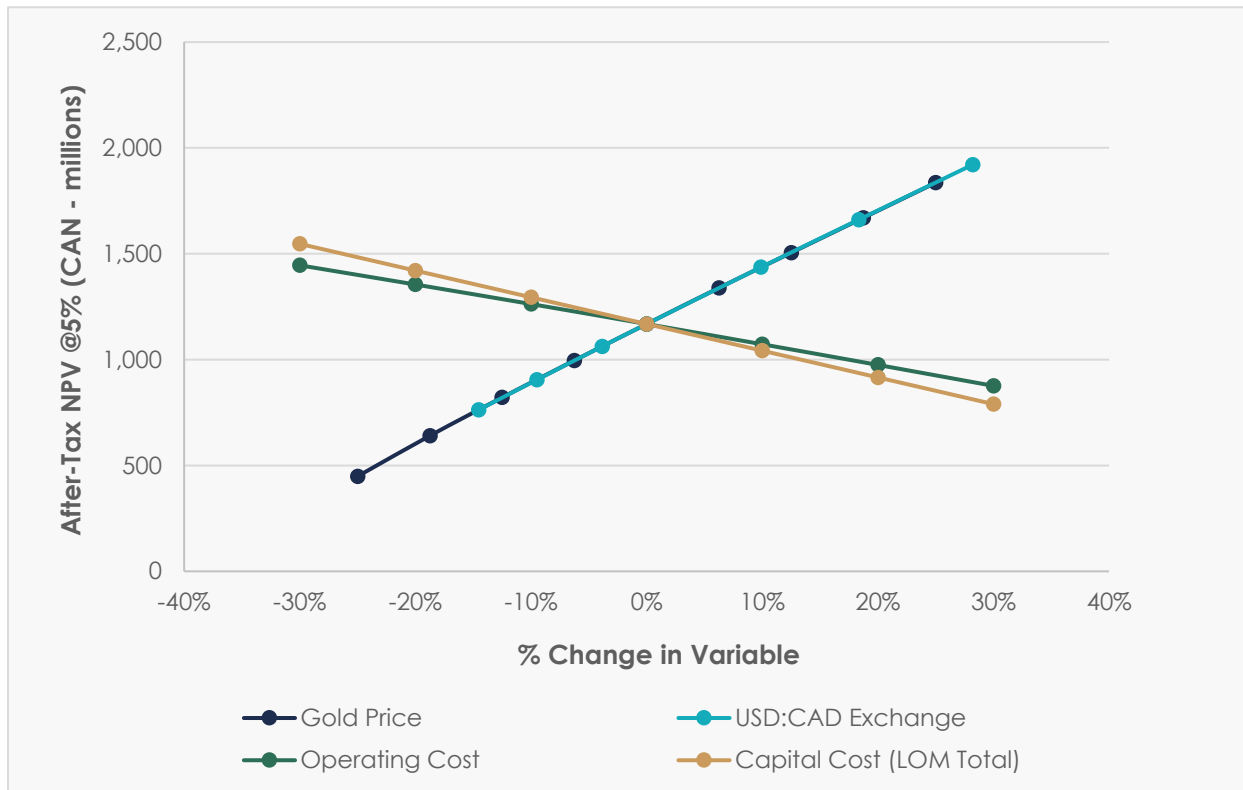

Figure 22-4: Sensitivity of the net present value (after-tax) to financial variables

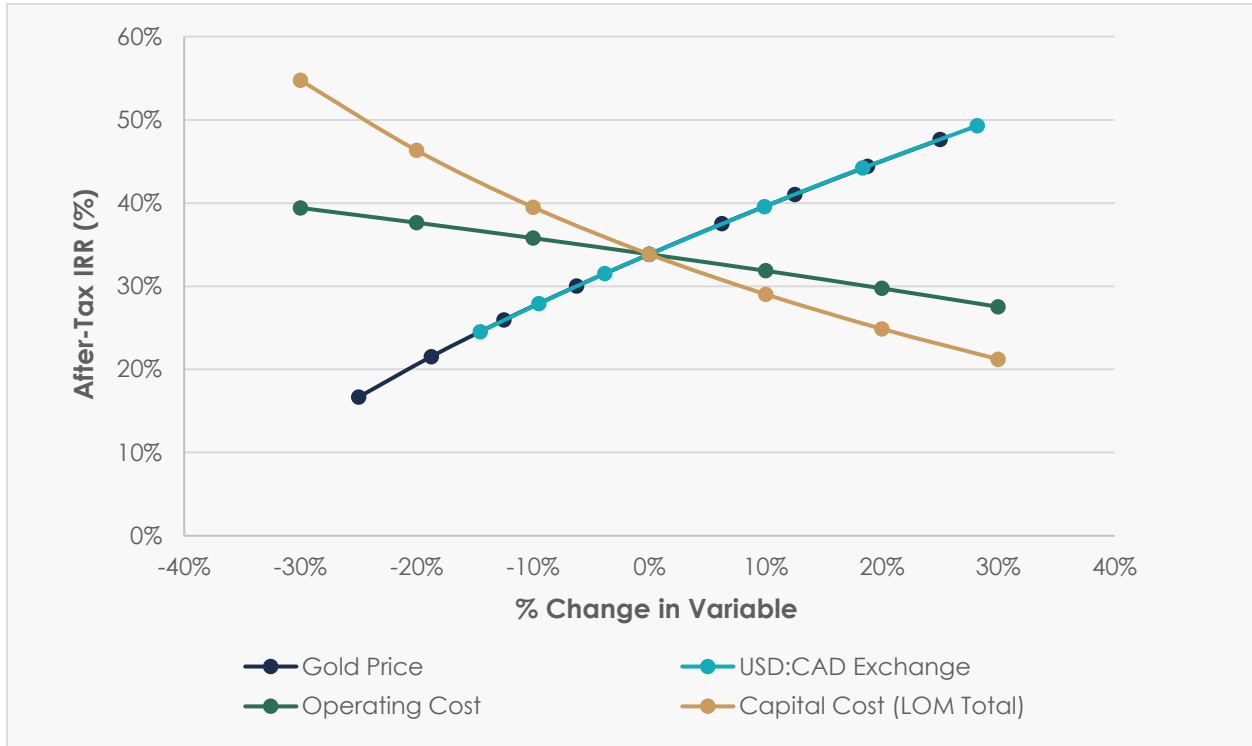

Figure 22-5: Sensitivity of the internal rate of return (after-tax) to financial variables



23. Adjacent Properties

23.1 Windfall and Urban-Barry Properties

Exploration in the Urban-Barry greenstone belt has led to the discovery of numerous gold prospects, all within a 20 km radius surrounding the Windfall deposit. Three properties holding gold deposits in adjacent projects are presented below and in Figure 23-1. The remainder of the tenements in the region principally consist of small land packages owned by junior exploration companies or prospectors. Recent exploration on adjacent properties by competitor companies and independent prospectors has focused on gold and base metals.

The QP has not verified the information presented below from the adjacent properties. This information is not necessarily indicative of the mineralization on the Windfall and Urban-Barry properties (the subject of this report).

23.1.1 Gladiator Gold Deposit - Bonterra Resources

The Gladiator deposit is located approximately 10 km southeast of the Windfall deposit. A mineral resource estimate and technical report were completed on this property with an effective date of July 30, 2021 and is available on the company's filings on SEDAR (Wilson and Gosselin, 2021). The Gladiator deposit is described as highly altered mafic volcanics cross-cut by gabbros, syenites, monzonites and quartz porphyry intrusions. Mineralization is mainly hosted within sheared veins of quartz-carbonate composition at the contact between the wall rocks and intrusions with smoky quartz veins. At least five distinct mineral zones have been identified.

23.1.2 Barry Gold Deposit - Bonterra Resources

The Barry Gold deposit is located approximately 10 km southwest of the Windfall deposit. The Barry Gold Deposit was recently acquired by Bonterra Resources on September 24, 2018. A NI 43-101-compliant technical report on an updated mineral resource estimate was carried out in 2021 with an effective date of July 30, 2021 and is available on the company's filings on SEDAR (Wilson and Gosselin, 2021).

Gold mineralization at the Barry deposit is hosted in albite-carbonate-quartz veins adjacent to altered wall rocks (silicified-carbonatized basalts).



23.1.3 Lac Rouleau - Osisko Mining Inc. (Formerly Beaufield Resources Inc.)

On October 19, 2018, Osisko acquired Beaufield Resources Inc., which included the Lac Rouleau Claim Block located approximately 5 km from the Windfall deposit. It contains three main gold mineralized zones (Zones 14, 17 and 18) and six showings (1, 2, 3, 4, Quesnel and Cominco showings), mainly surrounding Rouleau Lake. Mineralization is generally hosted in altered volcanic rocks adjacent to quartz-feldspar porphyry intrusions. A technical report was produced in 2018 (Beauregard et al., 2018). No mineral resource estimate was carried out in the Lac Rouleau Claim Block.

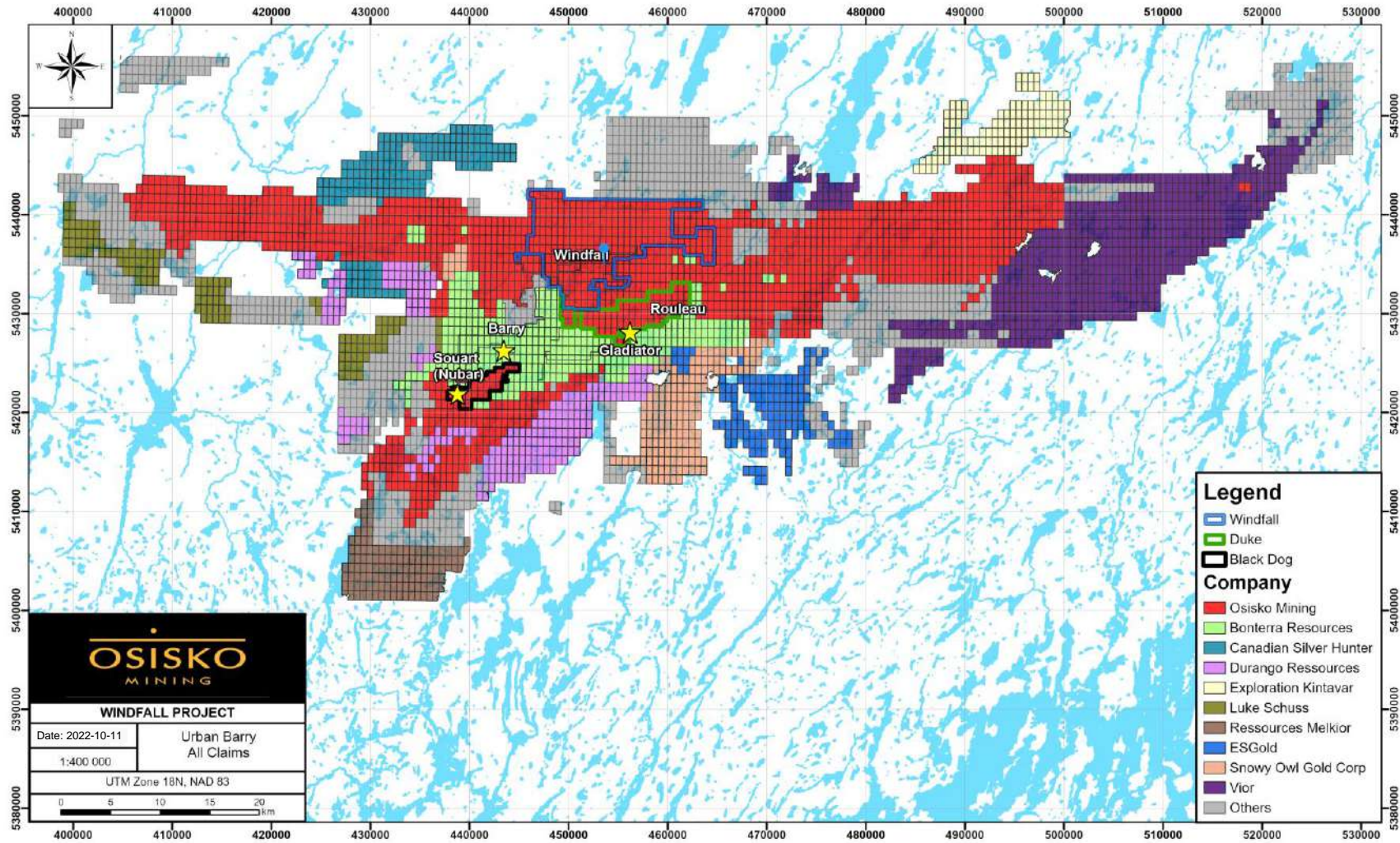

Figure 23-1: Properties and deposits in the vicinity of the Windfall and Urban-Barry properties as of October 11, 2022



24. Other Relevant Data and Information

24.1. Project Organization

24.1.1. Engineering and Procurement

All phases of the Project, including detailed engineering, procurement and construction activities, will be performed under the direction of the Osisko Vice-President, Engineering and Construction.

The mining team, including technical and engineering services, will manage and support the mine development of the Project.

Permitting and project financing will be supported by Osisko Environmental and Financial teams respectively.

Osisko has an internal experienced mine project development team and will be in charge of the Project management functions for the Windfall Project. The team consists of highly experienced individuals with knowledge of the local construction conditions and contractors. They have successfully managed projects in difficult conditions and remote environments for the engineering and planning stages through construction to commissioning and operations.

The Osisko technical and engineering group will supervise the detailed engineering of the Project. Prior to the FS, detailed engineering and procurement of several surface infrastructure (grinding mills and motors) were significantly advanced. Phase 1 of the water treatment plant detailed engineering is also ongoing. The procurement process for underground mobile equipment, mechanical equipment and electrical equipment was also initiated. Engineering firms will be responsible for the following procurement functions:

- Technical specification and scope of work documents;
- Technical and economical evaluations;
- Short list meetings;
- Purchase order requisition preparation;
- Drawing management and approval;
- Reception and coordination of vendor maintenance and operational documents.

The Osisko technical and engineering team is responsible for the following procurement functions:

- Bid request;
- Addenda;
- Reception of bids;
- Final negotiation;



- Contract award;
- Purchase order release;
- Progressive payment;
- Fabrication Shop visits;
- Site logistics.

Due to the complexity of major process equipment transportation, Osisko will retain the services of a specialized company in international logistics services.

24.1.2. Construction Management

Osisko will provide project construction management services under the direction of the Construction Manager. The Construction Management Team ("CMT") will include the following services:

- Site supervision;
- Reporting;
- Project cost control;
- Health and safety;
- Scheduling;
- Site procurement and logistics.

It is recognized that an effective health and safety program during the Project is a necessity. The success of the construction safety program is contingent upon its enforcement at all stages of the Project, including design, construction planning, construction execution, and start-up and commissioning.

The CMT will receive technical support from vendor's representatives who will assist in most of the major process and mechanical equipment installations.

The CMT will also follow the Windfall procedures and work methods to ensure the protection of the environment. Furthermore, the CMT will work closely with each department of the operations group to ensure proper installation and functional results. During the construction phase, personnel from operations will be integrated into the construction team as coordinators and supervisors.



The Windfall operations group will support the CMT for the following services during the construction phase:

- Staff payroll;
- Public relations;
- Accounting support;
- Environmental and permitting;
- IT support;
- Medical and first aid;
- Site security;
- Site logistics.

Figure 24-1 shows the general Project Engineering, Procurement and Construction Management Team organizational chart.



**Construction Management
Organizational Chart**

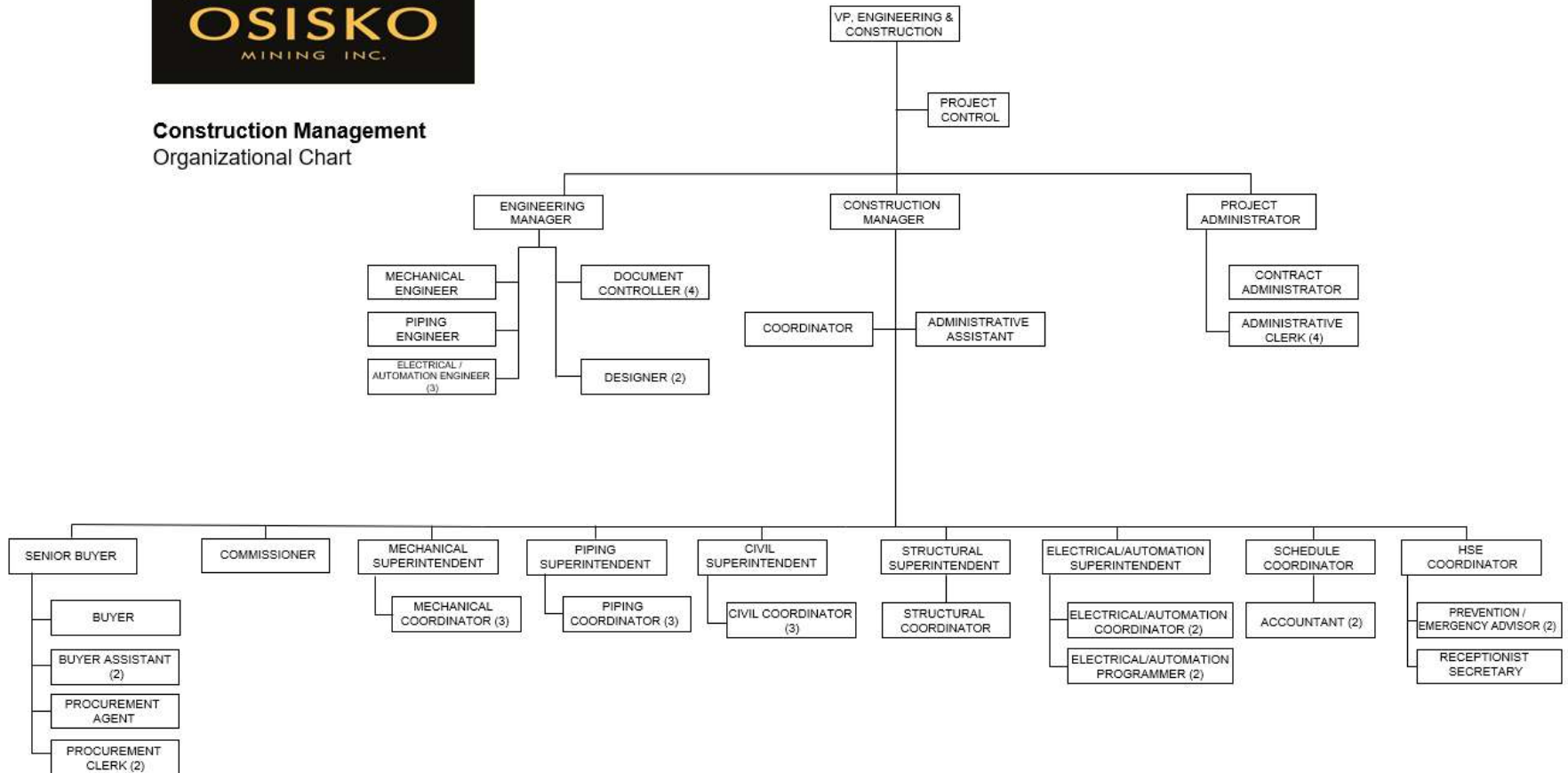

Figure 24-1: General Project Engineering, Procurement and Construction Management team organizational chart



24.1.3. Project Execution Plan

This execution plan is preliminary in nature and will be adjusted and refined during the next phases of the Project.

The durations and milestones for the major project activities have been extracted from the detailed project schedule and are shown in Table 24-1.

Table 24-1: Key project activities

Item Description	Start Date	Completion Date
Feasibility Study		Q1 2023
Environmental Impact Assessment ("EIA") Submittal		H1 2023
Detailed Engineering	Q4 2022	Q2 2024
Permit for Project Construction		Q2 2024
Process Plant Construction	Q2-2024	Q3 2025
Mine Development Start	Q2 2024	
Process Plant Commissioning	Q3 2025	

Upon completion of this FS, and as part of the long-lead project development activities, Osisko plans to proceed with the detailed engineering phase of the Project with a targeted completion by Q2 2024. Detailed engineering will be initiated for each area as required by the project schedule. The environmental impact study is planned to be submitted in H1 2023. Following this, the environmental impact assessment review process will continue and the consultation process for permits required for construction and operation of the Project facilities will be initiated. The preliminary project execution schedule, developed in this FS and described herein, covers the period from the start of project development activities up to the process plant commissioning in Q3 2025.

The schedule includes consideration of the already existing exploration infrastructure, various studies, the environmental permitting process, basic engineering, the procurement of long lead items and critical equipment, detailed engineering, construction, and commissioning of the facilities, including the power line and main substation, processing installations, tailings and water management infrastructure and site infrastructure required for the Project.

On-site construction at the Windfall Project is planned to start in Q2 2024, following receipt of the provincial decree and required authorizations and permits. Site preparation and bulk excavation will start in Q2 2024 and the remainder of the construction works will follow until completion in Q3 2025. This period will last approximately 16 months. This is in line with recent projects of similar scope and size.



An analysis of the detailed Project construction schedule allowed for the development of a preliminary workforce distribution as shown in Figure 24-2, based on a 10-hour work day and a 14-day on-site/7-day off-site work schedule. The mine development and operation headcount includes contractor support for the Project development and operation. The preliminary on-site workforce requirement is expected to peak at approximately 1,080 individuals during the construction phase (January 2025). The total estimated workforce accounts for the development of the underground mine, direct and indirect construction labour, along with commissioning crews. An allowance for Osisko CMT and Windfall operations staff has also been included.



Figure 24-2: Mine Development and Construction workforce forecast

The Project's critical path includes the approval of the environmental impact assessment reports followed by the reception of the construction and operations permits. This will include the approval of the updated mine closure plan, the emission of the mining lease and the wood-cutting permits associated with the possible restrictions' periods for fauna.



The process plant construction is scheduled to begin in Q2 2024. The excavation and building foundations for the permanent camp to accommodate the construction manpower ramp-up and the process plant will be the first priorities. The structural steel erection and building envelopes will follow, aiming for an enclosed process plant by the end of Q4 2024. While the building siding and roofing is proceeding, internal equipment foundations and slabs will be built, followed by mechanical, piping, electrical and automation installation work to be completed by Q3 2025. Pre-operational verification and commissioning will be completed to allow processing of the first mineralized material in Q3 2025.

Although the longest equipment deliveries are approximately 16 months after issuing of the order, none are on the Project's critical path on the current plan as the SAG and ball mills have been purchased. Technical documentation for the procurement of all underground mine mobile equipment, as well as mine surface and process plant major mechanical and electrical equipment has been completed. Equipment purchase will proceed by priority as required by the project schedule.

The dates of the engineering and procurement schedule in this plan will allow for a high-level of design completion to support the construction contract bid process. With such a level of engineering, Osisko will have improved control on the Project's costs and schedule.



25. Interpretation and Conclusions

25.1. Overview

A2GC, BBA, Entech, GCM, Golder and WSP were mandated by Osisko Mining in April 2022 to prepare a feasibility study conforming to NI 43-101 standards to demonstrate the technical and economic viability of the Windfall Project. The Project is based on the 2022 Mineral Resource Estimate (“MRE”) prepared for the Windfall deposit.

This NI 43-101-compliant technical report on the Windfall Project was prepared by experienced and competent independent consultants using accepted geologic and engineering methodologies and standards. It provides a summary of the results and findings from each major area of investigation including exploration, geological modelling, mineral resource, mineral reserve estimate, plant feed estimations, mine design, metallurgy, process design, infrastructure, environmental management, tailings and water management, capital and operating costs and economic analysis. The level of investigation for each of these areas is considered to be consistent with that normally expected with a feasibility study (“FS”) for resource development projects.

The mutual conclusion of the qualified persons (“QPs”) is that the Windfall Project, as summarized in this FS, contains adequate detail and information to support the positive feasibility economic outcome shown. The Windfall Project contains precious metal resources that can be mined by underground methods and recovered using conventional processing technologies. To date the QPs are not aware of any fatal flaws in the Windfall Project and the results are considered sufficiently reliable to guide Osisko Mining management in a decision to further advance the Project. This would typically involve completion and submission of the Environmental Impact Assessment (“EIA”) and the initiation of detailed engineering studies.

25.2. Resource Database

The QP, Pierre-Luc Richard, P. Geo., is of the opinion that the drilling, sampling, and assaying protocols in place are adequate. The database for the Windfall Project is of good overall quality. In the QP’s opinion, the Project database has been adequately validated and is suitable for use in the estimation of mineral resources.



25.3. Mineral Resources

The MRE reflects the status of the geological interpretation supported by drilling, underground mapping and bulk sample results. The resource includes infill drill hole information collected during the 2022 drilling program, which targeted mainly the Lynx zones and the Caribou 2, F-Zones, and Underdog zones. The mineral resource estimation is constrained in 579 gold-bearing individual solids. The mineralization wireframes were modelled based on the geological interpretation of the deposit's lithology, mineralization style, alteration, and structural features.

The block modelling parameters were defined based on the geological context and statistical studies of the drill hole data.

The MRE uses a base cut-off of 3.5 g/t Au.

The resource area measures 3.0 km on strike, 1.7 km wide, and is 1.6 km deep. The estimate was based on a compilation of 4,834 surface and underground drill holes. The estimate is categorized into the Measured, Indicated, and Inferred resources categories based on data density, search ellipse criteria, drill hole density, and reliability of the geological and grade continuity. The effective date of the estimate is June 7, 2022. Mineral resources are not Mineral Reserves as they do not have demonstrated economic viability.

The QP considers the report and the resource estimate to be reliable and thorough, based on the quality of the data, reasonable hypotheses, and parameters, which follow the NI 43-101 criteria and the CIM Definition Standards.

After conducting a detailed review of all pertinent information for the Windfall Project and completing the MRE, the following conclusions have been drawn:

- Geological and reasonable grade continuity have been demonstrated for the 579 gold-bearing lenses on the Project;
- Using a cut-off grade of 3.5 g/t Au, it is estimated that the Project contains 811,000 tonnes at an average grade of 11.4 g/t Au for 297,000 ounces of gold in the measured category, 10.3 million tonnes ("Mt") at an average grade of 11.4 g/t Au for 3,754,000 ounces of gold in the indicated category and 12.3 Mt at an average grade of 8.4 g/t Au for 3,337,000 ounces of gold in the inferred category;
- It is likely considered that additional diamond drilling would upgrade most of the Inferred resources to Indicated resources;
- The potential for adding new resources with additional drilling on the Project is considered to be good at depth, mainly in the Lynx and Underdog areas. The mineralization is open down plunge and towards the northeast.



25.4. Mineral Reserves

The Mineral Reserves outlined in this report are based on Measured and Indicated Mineral Resources, and do not include any Inferred Mineral Resources. The Mineral Reserves follow NI 43-101 requirements and the CIM 2014 Definition Standards.

The total Proven and Probable Mineral Reserves at Windfall are estimated at 12.2 million tonnes at 8.06 g/t Au for 3.16 million ounces of gold and grading 4.18 g/t Ag for 1.64 million ounces of silver.

Factors that may affect the Mineral Reserve estimates include: adjustments to gold price and exchange rate assumptions; changes in operating and capital cost estimates; dilution adjustments; changes to hydrogeological and underground dewatering assumptions; ability to permit the Windfall Project; and changes to modifying factor assumptions, including environmental, permitting and social licence to operate. There is upside potential for the estimates if mineralization that is currently classified as Inferred Mineral Resources, which is contained within mineral reserve mining blocks and is being milled as 0 g/t dilution, is converted to Mineral Reserves following further definition drilling not currently included in the study.

25.5. Mining Methods

The mining plan utilizes mining methods appropriate to the current understanding of the geological, geotechnical and hydrological properties of the deposit.

The Feasibility mine plan has been developed using anticipated diamond drilling requirements and its subsequent delay to development, mill throughput targets and anticipated trucking capacity based on average haulage distances. The plan aims to maximize efficiency and utilizes achievable rates for the selected equipment fleet.

The constraints and limits applied to the schedule are suitable to support the Project economics.

25.6. Metallurgy and Processing

Metallurgical testwork was conducted using material from various zones within the Windfall deposit including: Main (Zone 27 and Caribou), Lynx, Triple Lynx, Lynx 4 and Underdog. Representative samples were selected considering different rock types, precious metal grades and special location (depth and spatial distribution) within the deposit. The projected metallurgical recovery was established using the results of gravity recovery testwork followed by leaching testwork on composites from the various zones.



Several E-GRG tests were performed on each of the zones to obtain a more reliable idea of the gravity recoverable gold ("GRG").

Leaching optimization test works have been performed to improve the flowsheet. These testworks realized on the same samples have given similar results as variability testworks. Metallurgical testwork to date has confirmed that good precious metal recoveries can be achieved using a conventional process consisting of crushing and grinding to 37 μm (P80), with gravity recovery followed by whole ore leaching (36 hrs) of the gravity tailings.

Filtration and paste backfill testing programs were carried out by Pocock Industrial Ltd., Paterson & Cooke and Golder on projected Windfall detoxified tailings. The results show the amenability of producing paste backfill and dry stack for specific design criteria.

- The desired tailings solids concentration for dry stacking (84% w/w) can be achieved using pressure filtration;
- A paste recipe made with 3.11% of 90/10 binder reaches a UCS of 175 kPa after a curing time of 14 days (as required by the mine plan).

25.6.1. Process Flowsheet

Based on the testwork conducted, the process flowsheet consists of primary crushing, followed by a grinding circuit consisting of a SAG mill (in close circuit with a pebble crusher) and ball mill (in close circuit with cyclones – SABC circuit). A gravity circuit followed by intensive leaching recovers coarse gold from the cyclone underflow, while the cyclone overflow is treated in a carbon-in-pulp circuit. Gold is recovered in an Adsorption-Desorption-Reactivation ("ADR") circuit followed by electrowinning ("EW") cells.

The tailings filtration plant is located less than 1 km southeast of the Windfall process plant building. The plant consists of pressure filters and their ancillaries, paste mixers, paste pumps, a clarifier, a binder storage and dosing system and a dry stack storage facility. The totality of the process tailings is filtered. Based on the mine plan, approximately 39% of the tailings are transformed into paste backfill. The remaining tailings are disposed of as dry stack.

25.6.2. Metal Recovery Projections

Based on the proposed flowsheet, the overall projected metallurgical recovery values for gold and silver from the Windfall deposit are presented in Table 25-1.



Table 25-1: Projected metallurgical recoveries values for Au and Ag

Composite	Gravity				Leach (Gravity tails)				Overall	Overall
	Au distribution (%)	Ag distribution (%)	Au recovery (%)	Ag recovery (%)	Au distribution (%)	Ag distribution (%)	Au recovery (%)	Ag recovery (%)	Au recovery (%)	Ag recovery (%)
Main	33	21	31.9	20.6	68	79	90.0	76.1	93.2	81.1
Lynx	37	23	36.3	23.0	64	77	92.8	77.7	95.4	82.9
Triple Lynx	33	31	32.7	30.6	67	69	89.4	76.8	92.9	83.9
Lynx 4	26	18	25.2	17.5	75	82	88.9	82.6	91.7	85.6
Underdog	37	27	36.3	26.7	64	73	93.3	73.2	95.8	80.4



25.7. Infrastructure

The Project benefits from existing infrastructure developed during the exploration stage. Some of the existing components will be improved or increased in capacity and will be considered in the design of the required infrastructure for the Project, as listed below.

Mining infrastructure is planned around the existing exploration ramp and waste rock / overburden stockpiles.

The Windfall Project considers the following buildings and site infrastructure as existing:

- Windfall Site access road;
- Main zone portal with underground mine services (compressed air, electricity, ventilation intake);
- Waste rock stockpile;
- Surface water management ditches, ponds, and pumping stations;
- Water treatment plants;
- Exhaust raise and fan;
- Hybrid secondary WAN link (fibre optic and microwave radio);
- Light structure, fabric-covered domes;
- Meteorological station;
- Borrow pit;
- Diesel generators;
- Telecommunication tower and private LTE system for the surface and underground mine.

The following elements are considered separate from the Project, as they are led by subsidiaries of the Cree First Nation of Waswanipi ("CFNW"), the main one being Miyuukaa. CFNW will be responsible for and supply the following electrical infrastructure required by the project:

- MICO step-up substation (25 kV to 69 kV) to interconnect with Hydro-Québec Waswanipi substation;
- 69 kV overhead transmission power line and MICO substations;
- Windfall step-down substation (69 kV to 13.8 kV) located in the vicinity of the Windfall Project;
- Fiber optic WAN link to Waswanipi as optical ground wire ("OPGW").



The following existing infrastructure is considered outside the scope of the Feasibility Study, but remains in use for exploration:

- 300-person capacity exploration camp complex, including potable water and sewage systems;
- Helipad;
- Core logging buildings;
- Storage domes;
- Overhead power lines and camp area genset.

The Project will require new key infrastructure as follows:

- Process plant complex including crushing line, offices, dry and warehouse;
- Tailings filtration and paste backfill plant;
- Camp complex including dormitories, cafeteria and dining room, fitness and game centre, welcome centre, and laundry facilities;
- First Nations cultural centre;
- Potable water and sewage management systems;
- Gatehouse;
- Truck shop;
- Production core shack building that will also house the emergency vehicles;
- Extension of the existing waste rock stockpile;
- Overburden stockpile;
- Ore stockpile;
- Tailings storage facility;
- Surface water management facilities, including ditches, ponds, pumping stations, and piping;
- Site service and hauling roads;
- Borrow pits;
- Materials laydown and storage area;
- Domestic waste management storage area;
- Lynx zone portal with underground mine services (electricity, ventilation intake, fuel distribution);
- Exhaust raises and fans;
- Fire protection water storage, pumping stations, and distribution systems;



- Diesel, gasoline and propane storage and distribution systems;
- Upgrades to the existing water treatment plant;
- Overhead 13.8 kV power lines;
- An additional telecommunication tower;
- A local integrated operations centre;
- Regional administration offices and warehousing (locations not yet determined).

25.7.1. Tailings Management Facility

All processed tailings will be filtered. Around 60% of the tailings generated from ore processing will be directed to a surface tailings management facility ("TMF") as a stack located northeast of the filtering plant, while the remaining will be returned underground as a paste backfill material. The surface tailings will be hauled by trucks and compacted in a controlled manner in a dry tailings stack. It should be noted that the terminology "dry stack" refers to the concept of the structure and is not related to the water content of the filtered tailings in the stack. The TMF is developed for a total capacity of 9.0 Mt of tailings, which includes a contingency of around 0.5 Mt based on the LOM. It will be constructed in three phases to promote progressive reclamation.

To facilitate water drainage, limit potential ponding of water and promote the desaturation of the tailings, a drainage system will be constructed on and at the base of the tailings facility.

Contact water from the TMF will be collected and conveyed to two ponds using a network of collection ditches. The water stored in the ponds will be treated prior to being recirculated to the process plant or discharged to the environment. Diversion ditches will surround the TMF to collect and redirect non-contact water to the environment.

The tailings are potentially acid generating ("PAG"), leachable for metals and cyanide-bearing. The soils foundation is a relatively permeable material. For these reasons, the entire area of the TMF and contact water management infrastructure will be lined with a linear low-density polyethylene geomembrane to provide an adequate groundwater protection measure.

25.7.2. Water Management

The following water management infrastructure is considered as existing:

- The collection pond;
- Perimeter ditches around the existing waste rock stockpile ("WRS");
- Ponds A, D and P and ditches around the WRS;



Pond SP1 will no longer be used.

Water management infrastructure for the mine will include:

- Non-contact water diversion ditches;
- Contact water collection ditches;
- TMF ponds and other collection ponds;
- Pumping systems including sumps, pumps and pipeline;
- Water treatment plant (“WTP”);
- Polishing pond;
- Existing water management structures that will be integrated with the new system of ditches and ponds.

25.7.3. Waste Rock, Ore and Overburden Storage

The lined WRS design capacity is 9.11 Mt. The volume of waste rock that will be used for construction purposes and that will need to be returned to the stockpiles during closure has been considered to ensure the WRS maximal capacity is not reached. Several phases of expansion have been planned, the last one being in 2030. Perimeter ditches will collect any contact water.

The lined ore stockpile will have a capacity of 157,750 t and is planned to be located next to the crushing plant. A perimeter drainage ditch that encircles the crusher pad is designed to collect the runoff water.

The topsoil to be stored and managed at the Windfall site comes mainly from the site preparation required for the construction of the TMF, the process plant, as well as the stockpiles and ponds. The identified site for the overburden stockpile can accommodate 638 100 m³. The overburden stockpile will not be lined with a geomembrane, but runoff water will be collected by perimeter ditches and directed to a sedimentation pond before it is treated and released to the environment.



25.7.4. Water Treatment Plant (WTP)

Water treatment will be required on the Windfall Project site to:

- Meet the Mining Effluent Discharge Criteria Form Provincial Directive 019 (MDDEP, 2012) and the Metal and Diamond Mining Effluent Regulations (“MDMER”) (Fisheries Act 2019) from Environment and Climate Change Canada;
- Aim, within economical and technical limits, to meet potential environmental discharge objectives (“EDO”) which have not yet been defined for the Project.

The water treatment system will be located southeast of the process plant, beside the filtration plant. Most of the water treatment equipment will be installed in the existing warehouse annexed to the bulk sample ammonia WTP.

25.8. Environmental Studies

The Windfall Project is subject to the provincial Northern EIA procedure. The EIA currently in progress will have to be completed and submitted.

The current Project definition provides a basis upon which most anticipated environmental and social impacts can be identified. No specific inordinate environmental risk to Project development was identified. Although there are some environmental and social sensitive elements, optimization could be made to eliminate or reduce the effect on these components. Consultation and engagement activities with local and First Nations communities may highlight additional issues and mitigation approaches.

Discussion with First Nations representatives has been initiated in order to establish a Social and Economic Participation Agreement (an impact and benefit agreement, or “IBA”).

Finally, the closure costs are estimated at \$83.3M, including direct and indirect costs (and an 18% contingency).

25.9. Market Studies and Contracts

Gold and silver are freely traded precious metal commodities on the world market, for which there is a steady demand from numerous buyers. The markets for gold and silver are global in nature and are unlikely to be affected by production from the Project. Limited effort is expected to be required to develop the doré marketing strategy.



This Feasibility Study assumes a long-term USD/CAD exchange rate of 0.77:1.00, a gold price of USD1,600/oz and a silver price of USD21.00/oz to support the base case economic analysis as summarized in Chapter 22. The CAD/USD exchange rate and metal prices were established by Osisko based on consensus pricing derived from bank analysts' long-term forecasts (November 2022), historical metal price averages and prices used in recent publicly-disclosed comparable studies that were deemed to be credible.

There are no refining agreements or sales contracts currently in place for the Project that are relevant to this technical report.

25.10. Capital and Operating Costs

The total pre-production capital cost for the Windfall Project is estimated to be \$788.6M (including indirect costs and contingencies). The total does not include a total of \$146.5M for:

- Sunk costs spent prior to the feasibility study for the purchase of process plant grinding mills (\$5.6M) and the environmental impact study (\$1.1M);
- Long lead items expenses planned before start of construction, including engineering studies (\$33.3M), logistics and warehousing (\$2.1M), mechanical and electrical packages (\$57.0M), camp (\$32.2M), material opportunity purchase (\$8M), mining fixed equipment (\$2.9M) and contingency (\$3.0M).

The cumulative LOM capital expenditure including costs for pre-production, sustaining, site reclamation and closure and salvage value is estimated to be \$1.4B.

The overall capital cost estimate developed in this study meets the AACE Class 3 requirements and has an accuracy range of –10% and +15%. Items such as sales taxes, permitting, licensing, and financing costs are not included in the cost estimate. The Project capital cost summary is outlined in Table 25-2.

Table 25-2: Project capital cost summary¹

Capital Costs (C\$M)	Pre-Production	Sustaining	Total
Mining	80.2	556.7	636.9
Mineral Processing and Filtration Plant	273.8	0.0	273.8
Mine Surface Facilities	0.0	3.7	3.7
Electrical and Communication	14.7	0.0	14.7
Plant Surface Facilities	63.9	0.0	63.9
Waste, Water and Tailings Management	69.5	26.0	95.5
Indirect and Owner's Costs	237.0	1.3	238.3



Capital Costs (C\$M)	Pre-Production	Sustaining	Total
Site Restoration	0.0	83.3	83.3
Salvage Costs	0.0	(18.7)	(18.7)
Subtotal	739.1	652.3	1,391.3
Contingency (P50)	49.5	0.0	49.5
Total Capital Costs	788.6	652.3	1,440.8

1- Capital costs do not include sunk costs and long lead expenses totalling \$146.5M

The average operating cost over the 10-year mine life is estimated to be \$176.67/t milled or \$726/oz (CAD). Table 25-3 below, provides the breakdown of the projected operating costs for the Windfall Project.

Table 25-3: Project operating cost summary

Cost area	LOM (\$M)	Average annual cost (\$M)	Average (\$/tonne milled)	Average LOM (\$/oz)
Mining	993.0	99.3	82.21	337.7
Process plant including filtration	492.0	49.2	40.76	167.4
Waste and, water management	76.0	7.6	6.30	25.9
General and administration	396.0	39.6	32.81	134.8
Electrical transmission line lease cost	176.0	17.6	14.59	59.9
Total	2,134.0	213.4	176.67	725.6

It is anticipated that an average of 500 employees (staff and labour) will be required for operations.

25.11. Indicative Economic Results

The economic/financial assessment of the Windfall Project was carried out using a discounted cash flow approach on a pre-tax and after-tax basis, based on Q4-2022 metal price projections in U.S. currency and cost estimates (CAPEX and OPEX) in Canadian currency. Inflation or cost escalation factors were not taken into account. An exchange rate of USD 0.77 for CAD 1.00 has been assumed over the life of the Project. The base case gold and silver prices are 1,600 USD/oz., and 21.00 USD/oz. respectively. Project economics were evaluated based on a forecast date to receive the construction permit in Q1 2024.



The cumulative cash flow for the Project (after-tax) is \$1,710.2 million over the planned mine life of 10 years. Over the LOM approximately 2.94 Moz Au, and 1.37 Moz Ag will be produced on a payable basis.

Over the life of the Project, it is estimated that approximately \$127M in royalties and \$0.72B in income and mining tax payments will be paid.

The pre-tax base case financial model resulted in an IRR of 40.1% and an NPV of \$1,685 M using a 5% discount rate. The pre-tax payback period is 2.0 years after the start of production.

On an after-tax basis, the base case financial model resulted in an IRR of 33.8 % and an NPV of \$1,168.4 M using a 5% discount rate. The after-tax payback period is 2.0 years after the start of production.

The LOM operating cash cost per ounce (Including by-product credits) is 587 USD/oz Au. The LOM cost all-in sustaining cost ("AISC") per ounce is 758 USD/oz Au derived from the total cash costs plus sustaining capital, closure costs and salvage value. The operating margin over the LOM has been estimated to be 1,013 USD/oz Au based on a gold price of 1,600 USD/oz.

25.12. Execution Plan and Schedule

The execution of the Windfall Project will be directly managed by the Osisko Construction Management Team ("CMT"). The engineering and construction works will be contracted out to qualified firms and contractors under the direct supervision of Osisko. Procurement and project control functions such as scheduling, cost control, site logistic and site supervision will be executed directly by Osisko personnel. Due to the complexity of major process equipment transportation, Osisko will retain the services of a specialized company in international logistics services.

An analysis of the detailed Project construction schedule allowed for the development of a preliminary workforce distribution based on a 10-hour work day and a 14 day on-site/7 off-site work schedule. The preliminary on-site workforce requirement is expected to peak at approximately 1,080 individuals during the construction phase (January 2025). The total estimated workforce accounts for the development of the underground mine, direct and indirect construction labour, along with commissioning crews.

Pending the completion of all studies and receipt of the required permits, the process plant construction is scheduled to begin in Q2 2024, with production planned to begin in Q3 2025.



25.13. Project Risks and Opportunities

As with most mining projects, there are risks that could affect the economic viability of the Project. Many of these risks are based on a lack of detailed knowledge and can be managed as more sampling, testing, design, and engineering are conducted. Table 25-4 identifies what are currently deemed to be the most significant internal project risks, potential impacts, and possible mitigation approaches that could affect the technical feasibility and economic outcome of the Project.

The most significant potential risks associated with the Windfall Project are delays in the construction of the CFNW electrical line, delays in permit authorization, construction union contract negotiations, labour availability, new technology risk and geological resource variability.

Many of previously noted risks can be mitigated with adequate engineering, planning and proactive management (refer to Table 25-4).

External risks are, to a certain extent, beyond the control of the Project proponents and are much more difficult to anticipate and mitigate; although, in many instances, some risk reduction can be achieved. External risks are things such as the political situation in the Project region, metal prices, exchange rates and government legislation. These external risks are generally applicable to all mining projects. Negative variance to these items from the assumptions made in the economic model would reduce the profitability of the mine.

There are significant opportunities that could improve the economics, timing, and/or permitting potential of the Project. The major opportunities that have been identified at this time are summarized in Table 25-5, excluding those typical to all mining projects such as changes in metal prices, exchange rates, etc. Further information and assessments are needed before these opportunities can be included in the project economics.

Table 25-4: Project risks (preliminary risk assessment)

Area	Risk Description and Potential Impact	Mitigation Approach
Geology and Mineral Resources	<u>Windfall deposit</u> 1. Gold grades estimated inside the mineralized lenses could vary due to the presence of nugget effect in the gold distribution of the deposit. 2. The variable geometry of the dikes and structural features is complex to model, as is the modelling of the mineralized lenses. The locations of mineralized lenses could be off slightly with variable shapes locally.	<u>Windfall deposit</u> 1. Underground definition drilling will increase the definition of the gold grade distribution. 2. Underground mapping and definition drilling will help define the shapes of the lenses and confirm their geological and grade continuity. 3. Continue collecting structural data with the ongoing infill drilling program and continue updating the



Area	Risk Description and Potential Impact	Mitigation Approach
	<p>3. The structural model is not entirely integrated as it is ongoing, along with the definition drilling program. The shape and geometry of the mineralization lenses could be impacted by further refinements of the structural model.</p>	<p>structural and mineralization models based on the additional information.</p>
<p>Underground Mine</p>	<ol style="list-style-type: none"> 1. Not achieving schedule priorities and cycle time estimates. This could increase operating costs and decrease production rates. 2. Low equipment availability could lead to higher operating costs and lower production rates. 3. Diamond drill program delays could lead to production delays. 4. Ramp congestion could lower haulage rates, impacting mill production. 5. Poor drill and blast performance could increase dilution or decrease mining recovery, resulting in an increased cost per ounce. 	<ol style="list-style-type: none"> 1. Utilization of short interval control processes, including dispatch, to assign priority headings and to document root causes when expectations are not met. Short term planning team in place to maximize utilization of workforce and equipment. 2. Critical spare part inventory on-site and strict preventative maintenance schedule for all equipment. Material moving equipment (LHDs and Trucks) rebuilt after 2 years and replaced after 4 years, in addition to stand-by units provided by OEM to be charged only on an as-used basis. 3. Diamond drilling activities included in Feasibility schedule and will continue to be an integral part of future schedules, both short-term and long-term. Short interval control inclusion. 4. Fleet management system in all equipment to provide advance notice of oncoming traffic, utilization of dispatch, secondary ramp access through Lynx to Main zone bypass. 5. High quality operator training, Engineering QA/QC review of all stopes with drill redesigns as required, blast designs based on hole surveys, complete stope reconciliation and lessons learned closeout report.



Area	Risk Description and Potential Impact	Mitigation Approach
Rock mechanics	<ol style="list-style-type: none"> 1. Despite the additional stress measurements completed, some uncertainty remains regarding the in-situ stress magnitudes and orientation at depths below 600 m. Higher or lower stress magnitudes could impact mining-induced seismic issues as well as dilution estimates. 2. Higher external dilution could be encountered for several reasons (e.g., rock mass conditions lower than expected). Higher external dilution can lead to lower mining recovery, lower grades, and higher operating costs. 3. Some stopes are located near or under lakes. A hydraulic connection could be made with the lakes and/or the crown pillar could become unstable. 	<ol style="list-style-type: none"> 1. Perform additional in-situ stress measurements below 600 m to confirm the stress assumptions. Rapidly install a microseismic monitoring system if seismic conditions develop. 2. Regular mapping and characterization of the rock mass as development advances. Install cablebolts from the undercut and overcut accesses to help control dilution, if found to be necessary. 3. Investigate the rock mass conditions in the crown pillars under or near lake prior to mining. Backfill crown pillar stopes tightly and rapidly.
Paste Backfill	<ol style="list-style-type: none"> 1. Performance of the backfill recipe and distribution network does not meet the requirements. Potential issues that can occur include: <ul style="list-style-type: none"> ■ The dilution of the stopes will be sensitive to the length of time the stopes will remain open. <ul style="list-style-type: none"> – A stope filling rate lower than expected will result in stopes being left open for a longer period, which can lead to more stope hanging wall instabilities; – A stope filling rate lower than expected could delay and/or stall the stope mining sequence. ■ Backfill strength lower than expected can cause more dilution from backfill. 	<ol style="list-style-type: none"> 1. Ensure that the planned CRF and paste backfill infrastructure include some flexibility, and that budgeted rates include some room for potential problems. Implement a quality control program for the backfill from the start of mining. Design sectors to have more stopes available than required to meet the production rate.



Area	Risk Description and Potential Impact	Mitigation Approach
Geotechnical and Hydrogeology	<ol style="list-style-type: none"> 1. Geotechnical characteristics of soils vary from those retained for the design of the basins. 2. If the groundwater inflow and groundwater flow conditions lead to: <ul style="list-style-type: none"> ■ lower flow than predicted, there may be a decrease of volumes available for feeding the concentrator and maintaining water temperature adequate for the concentrator cooling system; ■ higher flow than predicted, there may be an increase of volume for water treatment and additional infrastructure could be required to manage the additional volume. 	<ol style="list-style-type: none"> 1. Conduct additional field investigation to reduce uncertainty about soils characteristics even more. 2. Complete a hydrogeological study that includes the Bank fault and build a database with the location of inflows encountered in exploration drillholes and estimation of inflow rates.
Site Infrastructure	<ol style="list-style-type: none"> 1. Delays in Windfall site connection to the powerline to be built by third party could lead to: <ol style="list-style-type: none"> a. Delay in mine development; b. Increase costs during construction period. 2. There is only one road that provides access to the mine site. Any issues with the road during construction or operations may cause delays, logistical problems and increased costs. 	<ol style="list-style-type: none"> 1. <ol style="list-style-type: none"> a. Prepare an alternate Mine Plan to mitigate the impact; b. Prepare for alternate power plant for construction period. 2. Plan for frequent road inspections and refurbish infrastructure if required. Also, prepare a back-up plan to use the alternative road.
Process and Filtration Plant	<ol style="list-style-type: none"> 1. Overall gold recovery may be lower and operating costs may be higher than planned. 2. Water clarifier could be undersized leading to insufficient high quality clarified water production. 	<ol style="list-style-type: none"> 1. <ol style="list-style-type: none"> a. Perform statistical analysis on the data obtained in LOM and validate process design to cover variabilities. b. Also, perform DO tests to validate oxygen consumption and plant design. 2. Testwork should be completed prior to detailed engineering.



Area	Risk Description and Potential Impact	Mitigation Approach
Water Treatment	<ol style="list-style-type: none"> 1. Higher concentration of contaminant than predicted may require bigger WTP equipment and more reagent 2. More water to treat than predicted may require bigger pump, equipment and piping. 3. High concentration of non-regulated and untreated contaminant which could cause toxicity at the effluent would require to add treatment steps. 4. Higher cyanides concentration after cyanides destruction than predicted may require another cyanide oxidation step in the water treatment process. 	<ol style="list-style-type: none"> 1. Finalise the water quality model 2. Revise the water balance once the water quality model is up to date 3. Treatment targets will be reviewed to aim economically and technically feasible concentration as close as possible to the EDO once they are known for the Project 4. Further investigation on the performance of the cyanides destruction process would be required.
Tailings Management Facility	<ol style="list-style-type: none"> 1. If the behavior of the foundation soils or if the geotechnical properties of the tailings is worse than what is used in the design, the factors of safety could decrease below the designed target and dry tailings stack could fail leading to release of tailings. 2. If the tailings do not meet the pre-established specifications during their placement in the TMF, adjustments in the process and filtration plants could be required leading to an increase in OPEX and/or CAPEX. 3. If the water table in the filtered tailings stack is higher than expected, the factors of safety would decrease below the design target and the filtered tailings stack might fail leading to release of tailings 4. If the filtered tailings are not produced to design specifications or the TMF is not constructed to design specifications, then there may be increased production and release of acidity and metals. 5. Preliminary engineering assessment indicates potential to add 2 Mt of filtered tailings. 	<ol style="list-style-type: none"> 1. a. Conduct additional field and laboratory studies to better understand the foundations behavior and the behavior of the tailings-sludge mix. 1. b. Promote drainage and improve the mechanical properties of the tailings, e.g. by adding waste rock to the mix. 2. a. Operate a larger area and designate this area in Phase 1 of the TMF to allow for the placement of the tailings that do not meet the pre-established specifications. 2. b. Promote drainage and improve the properties of the tailings, e.g. by adding waste rock to the mix and designing granular drains at the base of the filtered tailings stack 3. Confirm the hydrogeotechnical properties of the tailings during the first years of operation 4. Confirm and monitor design to ensure specifications are met, ensure liner is operating as per specifications, and ensure robust treatment options are available. 5. Extended capacity to manage an increased life of mine.



Area	Risk Description and Potential Impact	Mitigation Approach
Procurement	<ol style="list-style-type: none"> 1. Some suppliers could not be able to supply the required equipment and material on time. This would cause delay in construction or require higher capital expenses. 2. Increased costs of raw material could lead to higher capital expenses. 	<ol style="list-style-type: none"> 1. Process to material purchase as soon as possible to secure costs and priority in fabrication chains, which Osisko is actually doing. 2. Plan for material purchase opportunity before construction period, which Osisko is actually doing.
Construction (Costs and Schedule)	<ol style="list-style-type: none"> 1. The water table is relatively close to the ground surface and may make the water management during earthworks more difficult 2. The construction season is short and the ability of a contractor to hire qualified staff can be an issue 3. Short construction period, which will result in process plant civil and concrete trade work being completed in winter conditions. This exposes the Project more than usual to the impact of inclement weather. Potential schedule delays, health and safety problems and increased costs. 4. Construction Union Contract Negotiations: The current provincial collective construction labour agreement with the ACQ (Association de la construction du Québec) ends in 2025. Negotiations and final labour agreement contract terms may result in construction delays and higher Project capital costs. 	<ol style="list-style-type: none"> 1. Include the necessity of a sufficient pumping capacity in the tender document for the earthworks, combined with more specific data about water level. 2. Shortlist potential contractors with a preliminary earthwork schedule to avoid the completion of earthworks in winter conditions. 3. Review construction schedule. Detail planning of heating and hoarding requirements. Investigate potential of using pre-cast or prefabricated modules to reduce onsite works during the winter. Add allowance for extended winter conditions. 4. Review construction schedule. Detail planning of heating and hoarding requirements. Investigate potential of using pre-cast or prefabricated modules to reduce onsite works during the winter. Add allowance for extended winter conditions.
Environmental, Permitting and Social License	<ol style="list-style-type: none"> 1. Permitting could lead to delay in the Project start and construction period could be extended. 2. Increasing Environmental, Social, and Corporate Governance ("ESG") awareness and pressure from market. 3. Project is not accepted by the local communities. Project delays and increased costs. 4. Inadequate consultation with First Nations groups could lead to the government delaying the Project until consultation requirements are fulfilled. 	<ol style="list-style-type: none"> 1. Integrate permitting lead time into the site preparation schedule for every work area and prepare for an optimize construction schedule. Keep close contact with the authorities throughout the process. 2. Deliberately embed ESG concepts into every aspect of the Project, from engineering to construction, procurement, commissioning, ramp-up, operation, and closure (Sustainability by Design). 3. Keep regular communication/consultation with stakeholders.



Area	Risk Description and Potential Impact	Mitigation Approach
	<ol style="list-style-type: none">5. If the overburden contact water quality does not meet environmental guidelines.	<ol style="list-style-type: none">4. Proactive stakeholder consultation process. Share consultation approach with government frequently during the environmental assessment. Include and document well traditional knowledge in the EIA report.5. Then a site redesign may be required to capture and treat overburden contact water; additional work to evaluate environmental risk.
Rehabilitation and Closure	<ol style="list-style-type: none">1. Rehabilitation cost can be impacted by detailed engineering of the TSF2. Potentially acid generating waste rock could result in an extended period of post closure operations until the water quality requirements are met.	<ol style="list-style-type: none">1. Review rehabilitation costs when major design changes are made during the Project life cycle.2. Perform geochemistry during the mine life cycle to improve the geochemistry characterization of the waste rock.
Ramp-Up	<ol style="list-style-type: none">1. Risk of not meeting Project ramp-up objectives, in terms of time and quality (recovery and throughput).	<ol style="list-style-type: none">1. Operational Readiness program combined with Integrated Operations business model and IOC environment.
General	<ol style="list-style-type: none">1. Availability of skilled mining labour for operations2. The application of newer technologies does not result in the anticipated benefits resulting in downtime or increased costs.	<ol style="list-style-type: none">1. Define the needs and develop a proactive hiring plan. Implement a training program prior to start-up to meet Project needs.2. Develop mitigation plan involving support from the technology suppliers and training for workers.



Table 25-5: Project opportunities

Area	Opportunity Explanation	Benefit
Geology and Mineral Resources	Windfall deposit 1. As the deposit remains open at depth and towards the northeast, additional exploration drilling in the vicinity of the Windfall Project could increase mineral resources. 2. Reducing the drill spacing by adding infill drilling would likely upgrade inferred resources to the indicated and measured categories while increasing the confidence in the distribution of the mineralization. 3. Continuing the underground mapping in the exploration ramp could lead to a better understanding of the distribution of the dikes and the geometry of the structural features and mineralization corridors.	Windfall deposit 1. Potential to increase resources. 2. Potential to convert inferred resources to the indicated and measured categories. 3. Better understanding and definition of the structural and mineralization models.
Underground Mine	1. Review blasting against paste backfill for adjacent stopes instead of contractor drilled V30 raise. 2. Increase the use of automation and technology. 3. Review reducing the minimum mining width to below 2 m before ELOS. 4. Conversion of inferred resources currently included in Feasibility mining blocks to reserves. 5. Review the use of 65t haulage trucks.	1. Potential to reduce operating costs and provide more flexibility to prepare stopes simultaneously. 2. Potential to increase productivity and reduce operating costs. 3. Potential to reduce mining dilution and increase stope grades. 4. Conversion of up to 1.3 million tonnes of inferred resource that is currently being milled as waste. 5. Potential to increase productivity and reduce operating costs.
Rock Mechanics	1. If the drilling and blasting quality is good, and rigorous stope back-analyses demonstrate that stope performance exceeds expectations, the strike length of stopes in certain sectors could be increased. 2. Go to underhand long-hole mining in higher-stress ground at depth. 3. If the rock mass proves to be of better quality than that suggested by the RQD block model (used as an input in the numerical model), the extent of the failed zone around	1. Increased productivity and cost savings. 2. Increase mined recovery of mineralized material and reduce payback period for capital development. 3. Reduced dilution estimate. 4. This would impact positively the mining-induced seismic issues, as well as dilution estimates at depth.



Area	Opportunity Explanation	Benefit
	<p>excavated stopes could be smaller than expected.</p> <p>4. The stress magnitudes measured at Windfall were found to be relatively high. In-situ stress magnitudes could be lower than assumed.</p>	
Geotechnical and Hydrogeology	<p>1. The contractant behaviour of some layers of natural soil leads to large retention berms.</p>	<p>1. More investigation, using CPT, could precise the soil characteristics and lead to smaller retention infrastructure</p>
Geochemistry	<p>1. If actual geochemical properties of excavated materials differ from materials tested as a part of geochemistry study.</p>	<p>1. The treatment system is needed less than expected; revision to water management plan, or release to environment.</p>
Processing	<p>1. Based on bulk sample results from Windfall, additional recovery could be achieved by optimizing gravity circuit.</p> <p>2. Perform statistical analysis for high Au grade ore without block model capping to the Process Plant and evaluate the flexibility of the gravity, intensive leach and CIP circuits.</p>	<p>1. Higher gold recovery.</p> <p>2. Operation cost optimization and higher gold recovery.</p>
Site Infrastructure	<p>1. Process plant and Infrastructure design can be further optimized.</p> <p>2. Trade-off contractor vs own mobile equipment fleet</p>	<p>1. With additional testwork, trade-off studies and engineering design effort, there is the potential to simplify and optimize the layout of the process plant and other project infrastructure. This could result in lower costs, shorter construction timelines and operational efficiency improvements</p> <p>2. Could lead to decrease in OPEX and better social acceptance.</p>
Water Treatment	<p>1. Recover process plant cooling water loop heat to reduce water heating cost of the WTP</p> <p>2. Compost WTP biological sludge to generated organic matter that could be used for closure</p>	<p>1. Integrate this option in the water balance to analyze benefit</p> <p>2. Run tests on the biological sludge generated during bulk phase.</p>
Ore, Waste, and Water Management	<p>1. Steepen the slope of the overburden stockpile</p> <p>2. Waste rock can be used as construction material for treated water basins, diversion ditches, roads and pads.</p> <p>3. Optimize the site water management strategy by updating</p>	<p>1. Use non-organic overburden as backfill to impound peat and organic topsoil (sort of codisposal).</p> <p>2. Reduction of infrastructure cost.</p> <p>3. This could potentially result in smaller site water management infrastructure as well as reduced water treatment operating costs.</p>



Area	Opportunity Explanation	Benefit
	the current site water model based on additional sampling data to confirm water management design criteria.	
Construction (Costs and Schedule)	<ol style="list-style-type: none">1. Some lithologies are NPAG – see if possible to isolate and use as construction material.2. Look at opportunities to reduce on-site construction requirements by using prefabricated buildings/structures, modules or pre-cast concrete.3. Optimize construction material management.	<ol style="list-style-type: none">1. Develop a waste rock management plan to identify and segregate the NPAG lithologies as early as possible in the project or coordinate NPAG rock excavation during the construction period.2. Reduce risks associated with the short construction schedule. Reduced manpower on site during construction phase.3. Reduce off site procurement of construction materials such as aggregate and clean fill by sourcing it from the project site. Additional testing of material to be potentially excavated during the construction phase may result in an opportunity to optimize the overall construction material requirements and reduce construction costs.
General	<ol style="list-style-type: none">1. Government Sustainability Programs: The Canadian and Quebec governments are developing programs to provide incentives for manufacturers and mining companies to implement new technologies and approaches to reduce their energy consumption and the impact of their operations on the environment.	<ol style="list-style-type: none">1. Aligned with Osisko's sustainability approach, there is the potential that the Windfall project might qualify for some of these governmental programs which could result in lower costs and an improved environmental footprint.



26. Recommendations

This NI 43-101-compliant technical report on Osisko's Windfall Project was prepared by experienced and competent independent consultants using accepted engineering methodologies and standards. It provides a summary of the results and findings from each major area of investigation including exploration, geological modelling, mineral resource, mineral reserve, mine design, metallurgy, process design, infrastructure, environmental management, waste, water and tailings management, capital and operating costs and economic analysis. The level of investigation for each of these areas is consistent with, or surpassing, that normally expected with a Feasibility Study.

The mutual conclusion of the qualified persons ("QPs") is that the Windfall Project as summarized in this Feasibility Study ("FS") contains adequate detail and information to support the positive economic outcome shown. The results of this study indicate that the Windfall Project is technically feasible and has financial merit at the base case assumptions considered.

In summary, the QPs recommend that the Project proceed with detailed engineering and procurement of long-lead items. It is also recommended that environmental and permitting continue as needed to support Osisko's development plans and project schedule.

An extensive work program, including additional exploration drilling, a fourth bulk sample, detailed engineering and purchase of long lead items, has been developed based on QP recommendations. The work program is estimated to cost approximately \$314.8M including a \$10.1M contingency. A breakdown of this budget is summarized in Table 26-1.

Table 26-1: Work program budget

Work related to Exploration	Budget	
	Description	Cost (\$M)
Underground Definition Drilling	140,000 m	24.5
Conversion Drilling	30,000 m	5.3
Exploration Drilling	20,000 m	5.0
Fourth Bulk sample development UG	-	97.9
Fourth Bulk sample development Surface	-	35.3
Contingencies	-	7.1
Work related to exploration subtotal	190,000 m	175.0



Long lead items, including engineering studies	Budget	
	Description	Cost (CAD)
EIA	-	1.3
Detailed Engineering	-	33.3
Camp Purchase	-	32.2
Material Opportunity purchase	-	8.0
Mechanical & Electrical Package Lists	-	57.0
Logistics & Warehousing	-	2.1
Mining Fixed Equipment	-	2.9
Contingency	-	3.0
Long lead items subtotal	-	139.8
Total	-	314.8

Analysis of the results and findings from each major area of investigation completed as part of this FS suggests numerous recommendations for further investigations to mitigate risks and/or improve the base case designs. Sections 26.1 and 26.2 provide additional details to support the recommended work program outlined in Table 26-1.

26.1. Exploration

In this stage, the QPs recommend addressing the following technical aspects of the Project:

26.1.1. Underground Definition Drilling

Definition drilling is recommended on the Project to upgrade Indicated resources to the Measured category. A drill spacing of 12.5 m, or less, and observations of the mineralization from underground openings are proposed to define resources in the Measured category.

A total of 140,000 m of drilling should be dedicated to the definition of the Measured resources, with main targets aiming at the proposed mining areas in the first years of the life of mine ("LOM") schedule.



26.1.2. Conversion Drilling

Conversion drilling, up to a vertical depth of 1,000 m, is recommended on the Project to upgrade Inferred resources to the Indicated category. A drill spacing of 25 m is recommended for the Indicated category. Additional drilling to evaluate the extensions of the Lynx Main, Triple Lynx (up-plunge and down-plunge), and Lynx 4 zones is also recommended. Approximately 30,000 m should be dedicated to this purpose, with a significant amount performed using underground drills.

26.1.3. Exploration Drilling

The objective of the exploration drilling program would be to continue investigating untested gold targets on the entire Windfall Project and any potential lateral and depth extensions of known mineralization. Positive results would potentially add Inferred resources and contribute to the renewal of the mineral resource of the Project.

On the Urban-Barry regional exploration front, the QP recommends that exploration work be performed to assess the mineralization potential outside the actual footprint of the known deposit, along favourable geological features present regionally (i.e., the Bank fault, the Cross fault, the Milner fault). A 20,000 m drilling program is recommended on regional targets in the vicinity of the deposit.

26.1.4. Bulk Sample in Lynx 4

A fourth bulk sample in the Lynx 4 zone would continue the development of the exploration ramp and provide additional underground drilling stations, aiding in the definition and conversion drilling programs proposed. This bulk sample would also provide a better understanding of the complexity of the mineralization in several areas. In addition, underground workings in the Lynx 4 area would allow access to the Bank deformation zone. This important structural feature of the Windfall deposit remains to be observed and characterized from underground.

26.1.5. Integration of Additional Types of Analysis in the Resource Block Model

In preparation to support the planning of the mining stopes, the QP recommends integrating channel sample results in the grade estimation of the resources to improve the definition of the Measured resources. As more underground openings should be developed, the growing set of channel data should transit to a significant input to be included in the resource estimations. As it is also recommended to continue the multi-element analysis program throughout the deposit to better optimize the metallurgical processes (e.g., Ag, Cu, S). The QP suggests that grade



estimations of the multi-element be included in future interpolation runs in the Windfall block models.

26.2. Engineering Studies

Metallurgical testwork and studies to support the Environmental Impact Assessment ("EIA") are currently underway. The QPs recommend that the following work be performed:

26.2.1. Underground Mining

For the next phase, it is recommended to:

- Perform detailed engineering of paste backfill distribution system to determine final specifications;
- Review block size in Mineral Resource model to test narrower minimum mining width.

26.2.1.1. Rock Engineering

Additional geomechanical data collection and interpretation work is recommended to address the data gaps in the geomechanical rock mass conditions:

- Perform geomechanical logging of oriented core in drill holes located in the Underdog mining zone and in the lower part of the Lynx mining zone, to confirm the rock mass conditions ahead of mining;
- Perform a supplemental strength testing program to further confirm the geomechanical domains definition. Supplemental testing data could also help in revising the intact rock strength envelopes. Core samples should be collected in the lower third of the mine, to gain knowledge of the intact rock properties where seismicity-related issues are more likely to occur;
- Efforts should be made to validate the measured stress field through field observations, and, if possible, supplemental stress measurements should be conducted at depth. Measurements could only be completed at 300 m and 600 m depth, leaving a data gap at depth. Furthermore, the orientation data was scattered, particularly at 600 m depth;
- Continue the geotechnical joint mapping currently performed by the site team. Once a good understanding of the condition of the joint surface per joint set will be acquired, the joint mapping could be simplified to only orientation, spacing and persistence, to capture the spatial variation of the geometry of the joint sets;
- Collect data on the water inflows intercepted in the exploration drill holes (date, location, inflow rates). Compile the data in a database that can be represented in 3D space. The



surface exploration drillholes should be cemented to limit water inflows into the underground workings;

- The rock quality designation (“RQD”) block model created by Osisko should be updated and maintained. It is a valuable tool to assess the conditions of the rock mass. It is recommended to update this block model each time there is a major update of the resources;
- The variation of the rock mass quality in and around the interpreted faults should be investigated in more detail before driving development and mining stopes near the faults. A better definition and understanding, in 3D, of the zones with lower rock mass quality will be beneficial for the detailed planning of the excavations. The geomechanical characterization and the geological interpretation of the faults should be performed together;
- Based on the degree of jointing encountered, consideration could, in the future, be given to performing discontinuum-based numerical analyses for the purpose of more explicitly examining the behaviour of structural discontinuities. This could help validate stope dimensions and crown pillars thickness, as well as refine dilution assumptions.

26.2.2. Metallurgical Testwork

The following tests and evaluation are recommended:

- Thickening, clarifying and filtration testwork to confirm the equipment sizing according to the selected supplier;
- Dissolved oxygen tests for oxygen plant sizing on a representative sample;
- Determine the potential mill feed grade variability to ensure correct sizing of gravity, intensive leach and leaching circuits.

26.2.3. Integrated Operations

To ensure optimal integrated operations, well aligned on Windfall's vision from the very beginning of the mine operations, to maximize production ramp-up, minimize training time and ensure rapid adoption of operational culture, it is recommended to proceed as early as Q2 2023 with:

- Update of the human factors analysis to reflect Windfall's latest operation vision and strategy;
- Finalization of the information flow value stream mapping from mine to shipping to complement the IOC UX interface and resource's function perimeters definition;
- Identification of the guiding principles for the Windfall Management Operating System according to Windfall's latest operation vision and strategy.



26.2.4. Waste, Water and Tailings Management

26.2.4.1. Waste Rock Management

The representativeness of the geochemical waste rock dataset should be periodically re-evaluated to ensure that it remains representative of waste rock that will be generated during operations. Supplemental sampling and characterization should be undertaken, as needed, to confirm the geochemical characteristics of waste materials.

It is recommended that the potential use or re-use of waste rock materials for on-site construction is evaluated. Material that will potentially be blasted during construction should be sampled and characterized according to the *Guide de caractérisation des résidus miniers et du minerai* (MELCC, 2020). In addition, it is recommended to further assess the suitability of using waste rock that will be generated during operations as on-site construction material.

If some waste rock can be used as a construction material, develop fill plans of the waste rock stockpile ("WRS"). These fill plans will ensure the material is adequately sorted and can thus be reused when and where needed on the site. If the material is not suitable for construction, and nothing else can be done with the waste rock, the material will be stored on the WRS, as proposed at the feasibility level of the project.

26.2.4.2. Water Quality

- Deep groundwater baseline: water sampling and analysis of deep groundwater should be performed to characterize the water quality that may enter the mine workings at depth;
- Groundwater baseline and protection aspects: field work and sampling should be performed at the tailings management facility ("TMF") site to define the baseline groundwater quality;
- Surface water baseline: water sampling and analysis at strategic locations should continue during operations in order to refine the surface water quality modeling;
- Updated water quality modelling should be completed on the updated water balance for the site to:
 - Finalize the water management plan and determine the design criteria for the water treatment plant design engineering;
 - Refine the predictions for operational and closure water treatment needs;
 - Refine predictions of underground, including geochemical testing of paste backfill to evaluate the leaching and acid generation potential prior to flooding the underground workings.



- Receiving environment water quality modelling should be developed as an addition to the updated site water balance and water quality model to identify risks to the receiving environment (aquatic life and human health).

26.2.4.3. Water Treatment

- Once the water quality modeling is completed, perform the water treatment plant detailed engineering;
- Further evaluation of the anticipated properties of water treatment sludge should be completed in support of sludge management planning.

26.2.4.4. Water Management

For the water management infrastructure, the following recommendations apply:

- Collect additional geotechnical data through field study, including geophysics, boreholes and test pits at the final locations of each basin;
- Refine the project to bring it to detailed engineering:
 - Optimize water management/water treatment strategy;
 - Update water balance and water quality model, integrating climate change scenarios;
 - Review infrastructure designs accordingly and bring to detailed engineering design.
- Where the liner is armoured with waste rock, perform geochemistry studies during the mine life cycle. If acid generation and metal leaching appear and start decreasing before the end of the operations, the closure scenario of the concerned infrastructure could be improved;
- Conduct dam breach assessments for the major water collection ponds planned for the site.

26.2.4.5. Tailings Management

For the next stage of the Project, the following elements are recommended:

- Refine, and bring to the appropriate detail level, the tailings infrastructure;
- Conduct additional field and laboratory studies to better understand the foundations nature and behavior in the sector of the tailings management infrastructure;
- Conduct additional laboratory studies to better understand the behavior of the filtered tailings-sludge mix;



- Review of liner requirements and selection, and geochemical compatibility with process water;
- Conduct a potential failure modes and effects assessment ("PFMEA");
- Conduct a trade-off study to select the best geotechnical mitigation measure for the TMF closure and the best moment for its implementation;
- Develop a tailings wind erosion mitigation plan to limit tailings transportation supported by an option analysis;
- Design an appropriate closure scenario, including identification/selection of the low-permeability cover system adapted to the quality of available borrow sources;
- Conduct a preliminary assessment of climate change effects on infrastructure as part of closure scenario evaluation;
- Continued evaluation of the geochemical characteristics of tailings blends that are representative of what will be generated during operations.

26.2.5. Environment and Permitting

As for the environmental aspects, the EIA study will need to be issued to begin the permitting process of the project. Following this submittal, the project team will follow the approval steps, such as the questions and answers period and the public consultations for the project. In parallel, the various permits needed to begin construction and operations will be prepared and submitted in a timely fashion so as to optimize the project's schedule.

In addition to this work, and following the evaluation of the project's impacts, compensation measures may need to be defined such as those for fish, wetlands or hydric environments. These activities will depend on the final impact evaluation that has yet to be completed.

26.3. Market Studies and Contracts

It is recommended that Osisko starts having discussions with transportation companies, logistics/security service providers and potential refiners to validate the security design criteria, protocols and define the terms of a future doré sales agreement.

26.4. Conclusion

Colin Hardie, QP, finds the recommendations and budgets to be reasonable and justified based on the studies and observations made to date. It is recommended that Osisko conducts the planned activities subject to funding availability and any other matters that may cause the objectives to be altered in the normal course of Project development.



27. References

- A2GC (2020). Ground Control Review at the Windfall Project. Technical memorandum. No. Ref.: 2139-WIN-001-M-20200210-01. Draft version. Dated 10 February 2020.
- A2GC (2021). Windfall Lake Project – Rock Engineering in Support of the Mine Design for the 2021 Preliminary Economic Assessment. Technical Report. Ref.: 2160-WIN-002-R-20210119-v2. Second draft version. Dated 26 February 2021.
- A2GC (2022). Windfall Lake Project – Rock Engineering in Support of the Mine Design for the 2022 Feasibility Study. Technical Report. Ref.: 2243-WIN-003-R2022-v1.
- Abitibi Géophysique Inc. (2017a). Levé IPower 3D Projet Black Dog, Canton de Barry, Québec, Canada, 29 p.
- Abitibi Géophysique Inc. (2017b). Levé OreVision® Projet Urban-Barry, Canton de Buteaux, Québec, Canada, Rapport d'interprétation, 22 p.
- Abitibi Géophysique Inc. (2017c). Levé OreVision® Projet Windfall, Canton d'Urban, Québec, Canada, Rapport d'interprétation, 24 p.
- Abitibi Géophysique Inc. (2018a). Levé OreVision® Projet Urban-Barry, Canton de Lacroix, Québec, Canada, Rapport d'interprétation, 21 p.
- Abitibi Géophysique Inc. (2018b). Hole-to-Hole 3D IP Windfall Deposit - Preliminary Report, 13 p.
- Abitibi Géophysique Inc. (2020). Levé de tomographie PP, configuration Pôle-Pôle (X-HOLE) - Rapport logistique et d'interprétation, Projet Lac Windfall, Canton de Urban, Eeyou Istchee Baie-James, Québec, Canada, 40 p.
- Archéo-08 (2007). Étude de potentiel archéologique. Projet Lac Windfall. Report prepared for Noront. Inc. 17 p.
- Archéo-08 (2018). Inventaire archéologique. Projet Windfall de la minière Osisko. Report prepared for Osisko Mining Inc. 62 p.
- Armstrong, T.J. (2006). Geological Report on the Windfall Property, Chibougamau Mining District, Québec, Canada; for Noront Resources Inc.; P & E Mining Consultants Inc., Report 125; August 28, 2006.
- Armstrong, T.J. (2007). Updated Geological Report on the Windfall property, Chibougamau Mining District, Québec, Canada; for Noront Resources Inc.; P & E Mining Consultants Inc., Report 138; June 20, 2007.



- Armstrong, T.J. (2011). Technical Report on the Windfall Property, Chibougamau Mining District, Québec, Canada; for Eagle Hill Exploration Corporation; P & E Mining Consultants Inc., Report No. 222.
- Arnold, C. (2021). Gravity Circuit Modeling Report Rev.10. FLSmidth. Quebec. Osisko – Windfall Project.
- Arnold, C. (2022). Gravity Circuit Modeling Report Rev.12. FLSmidth. Quebec. Osisko – Windfall Project.
- Ashbury, M. & Liu, S. (2018). Rheology test results summary for a CIL sample from the Windfall Project for Osisko Mining. SGS Project No.: CA20M-00000-801-16159-01.
- Bandyayera, D., Théberge, L., and Fallara, F. (2002a). Géologie de la région des lacs Piquet et Mesplet (32G/04 et 32B/13), Ministère des Richesses naturelles du Québec; Report RG 2001-14.
- Bandyayera, D., Theberge, L., Fallara, F. (2002b). Compilation géoscientifique – Géologie 1/20 000, 32G04-200-0102 – Lac Windfall. Ministère des Richesses naturelles du Québec, Série Sigeom SI-32G04B-C4G-02C.
- Bandyayera, D. (2006). Révision stratigraphique de la ceinture d'Urban-Barry. Ministère des Richesses naturelles du Québec, RP 2006-08.
- Barton, N., R. Lien, and J. Lunde (1974). Engineering Classification of Rock Masses for the Design of Tunnel Support. Norwegian Geomechanics Institute. In "Rock Mechanics," Vol. 6, No. 4, pp. 189-236.
- BBA, 2022. Technical note on Windfall's Integrated Operation Center. 3678039-000000-4T-ERA-0001.
- Beaulieu, M., 2021. Guide d'intervention – Protection des sols et réhabilitation des terrains contaminés. Québec, ministère de l'Environnement et de la Lutte contre les changements climatiques, 326 p.
- Beauregard, A.J. and Gaudreault, D. (1988). Evaluation Report on the Urban Property, Urban Township, Québec, Canada 32G/4, Shiva Ventures. GM48316.
- Beauregard, A.J., Gaudreault, D., Stephens, M. (2018). 2018 technical work report on the Lac Rouleau Bloc of the Urban project (according to NI 43-101F1). Urban-Barry Townships, Abitibi region, Quebec, Canada. October 12, 2018. 126p
- Bernard, D. (1999a). Drill logs for diamond drill holes ATO-97-17 to ATO-99-23 Alto/Noront Project, Urban Township, Québec; for Inmet Mining Corporation, 208 p. GM 57443.



- Bernard, D. (1999b). Drill logs for diamond drill holes ATO-97-3a, ATO-99-24 to ATO-99-33, Alto/Noront Project, Urban Township, Québec; for Inmet Mining Corporation, 186 p. GM 57413.
- Bergmann, H.J. (1977). Report on Geophysical Surveyx Completed for Shell Canada Limited by Prospecting Geophysics Limited on Grid Number 36, Barry Project, Québec, 10 pp. GM32467.
- Bieniawski, Z. T. (1989). Engineering Rock Mass Classifications: A Complete Manual for Engineers and Geologists in Mining, Civil, and Petroleum Engineering. John Wiley & Sons publishers, 272 pp. New York, NY, USA.
- Bill 70: An Act to Amend the Mining Act. (2013). National Assembly, Government of Québec, Chapter 32. Introduced Dec. 5, 2013, Fortieth Legislature, 1st session.
- Bouchard, R., and Girard, T. (2021). Assessment Report for the 2020 Soil Sampling Program, Urban-Barry Project, James Bay, Québec, 18 p.
- Brown, C. and Cheman, M. (2014). Hole-to-Hole 3D IP survey, Windfall Project; for Eagle Hill Exploration. Report 13N057. 22 p.
- Carter, T.G. (1992). A New Approach to Surface Crown Pillar Design. Proc. 16th Canadian Rock Mechanics Symposium, Sudbury, pp. 75-83.
- Carter, T.G. (2014). Guidelines for use of the Scaled Span Method for Surface Crown Pillar Stability Assessment. Proc. 1st International Conference on Applied Empirical Design Methods in Mining, Lima-Perú, June 9-11, 2014, 34 p.
- CEAA (2012). Canadian Environmental Assessment Act, 2012.
- Chaîne, D. (1997). Résultats des forages, Propriété Urban-Barry; For Ressources Orient Inc. Octopus, 60 p. GM 55698.
- Chance, P.N. (2009a). Summary Report of the 2007-2008 Underground Sampling Program, Windfall Property, Canton Urban, Abitibi Region, Québec; an internal report prepared for Noront Resources Ltd.
- Chance, P.N. (2009b). NI 43-101 Compliant Technical Report of the Windfall Property, Canton Urban, Abitibi Region, Québec. Prepared for Eagle Hill Exploration Corporation. Filed on SEDAR.
- Cheman, M. (2013). OreVision Induced Polarization Survey, Windfall Project. Report 13N067. 35 pages and pseudosections.



- Choquette, B., (2021). The geology of the Windfall gold deposit, Québec, Canada: Unpublished M.Sc. thesis, Sudbury, Ontario, Laurentian University, p. 201.
- Chown, E.H., Daigneault, R., Mueller, W., and Mortensen, J.K. (1992). Tectonic evolution of the northern volcanic zone, Abitibi belt, Quebec. Canadian Journal of Earth Sciences, 29: 2211-2225.
- CIM (2019), CIM Estimation of Mineral Resources & Mineral Reserves Best Practice Guidelines. Document available from CIM website at https://mrmr.cim.org/media/1129/cim-mrmr-bp-guidelines_2019.pdf, 75 p.
- Clark, L. M. (1998). Minimizing dilution in open stope mining with a focus on stope design and narrow vein longhole blasting (T), University of British Columbia, 336 pages. Retrieved from: <https://open.library.ubc.ca/cIRcle/collections/831/items/1.0081111>
- Clearview Geophysics Inc. (2017). Report on regional compilation and interpretation of IP/Resistivity surveys at the Windfall Project, NE Québec, 33 p.
- Côté, R. (1977). Summary Report, Barry Lake Project, Barry Lake Area, Québec; for Shell Canada Resources Limited, Volume I, 41 p. GM 38828.
- Côté-Lavoie and Girard (2021). Assessment Report for the 2021 Prospecting and Soil Sampling Program, Urban-Barry Project, James Bay, Québec, 22 p.
- Cotesta et al, 2014. Cotesta, L., C. O'Connor, R. Brummer, and A. Punkkinen (2014). Numerical Modelling and Scientific Visualisation – Integration of Geomechanics into Modern Mine Designs. Proceedings of the 2014 Deep and High Stress Mining conference, Sudbury, Canada, pp. 377-395. Australian Centre for Geomechanics: Perth, WA, Australia.
- Coyle, T. (1996). Report of diamond drilling, Urban Project, Freewest Block and Inmet Option, Urban Township, Chibougamau Mining Division; for Freewest Resources, 105 p. GM 54546.
- Coyle, T. (1998). Report on diamond drilling on the Windfall property, Urban Township, Québec; for Murgor Resources, 139p. GM 55791.
- Coyle, T. (2005). Drill logs diamond drill holes NOT-05-39 to NOT-05-82, Windfall Property, Urban Township; for Noront Resources Inc.
- CNG (2022a). Cree Nation Government. The Cree Nation of Eeyou Istchee. Online: <https://www.cngov.ca/community-culture/communities/>
- CNG (2022b). Cree Nation Government. The Cree Nation of Eeyou Istchee. Chisasibi profile. Online: <https://www.cngov.ca/community-culture/communities/>



- Cyanco Corporation (2019). Test Program to Evaluate Cyanide Destruction Options Using Cyanco SO₂/AIR – Based Technologies for the Treatment of Effluents from the Windfall lake Gold Project. Cyanco. Sparks, Nevada, USA.
- Daigneault, R., Mueller, W., and Chown, E.H. (2002). Oblique Archean subduction: Accretion and exhumation of an oceanic arc during dextral transpression, Southern Volcanic Zone, Abitibi Subprovince Canada. In: Precambrian Research, v. 115, p. 261-290.
- Daigneault, R., Mueller, W. and Chown, E.H. (2004). Abitibi greenstone belt plate-tectonics: the diachronous history of arc development, accretion and collision. In: The Precambrian Earth: Tempos and events (Eriksson, P., Altermann, W., Nelson, D., Mueller, W.U., Catuneanu, O., Strand, K. (editors)). Developments in Precambrian Geology 12, Elsevier, pp.88-103.
- Davis, D.W. (2016). U-Pb Geochronology of Pre- and Post-Mineralization plutons from the Windfall Project, Urban-Barry Greenstone Belt. *Unpublished data*.
- Desrochers, J.-P. (2007). Report on the 2004-2006 Trenching and Drilling Programs on the Windfall Project, Barry Township, Québec. 833 p. GM 63038.
- Desrochers, J.-P. (2012). Assessment Report for Windfall Lake Project, Urban Township, Abitibi Region, Québec; Windfall Lake Project Diamond Drilling Report 2012 Exploration Drilling. 30 p. GM 67183.
- Desrochers, J.P. (2013). Assessment Report for the 2011-2012 Drilling Program Windfall Project Urban Township Abitibi Region, Quebec; for Eagle Hill Exploration, 84 p. GM 68042.
- Desrochers, J.P., and Blouin, S. (2015). Assessment Report for the 2013 and 2014 Drilling Programs, Windfall Project Urban Township Abitibi Region, Quebec; for Eagle Hill Exploration, 10757 p. GM 69122.
- Dubé, B. and Mercier-Langevin, P., 2020. Gold Deposits of the Archean Abitibi Greenstone Belt, Canada. Society of Economic Geologists, Special Publication, no. 23, p. 669-708.
- ECCC (2016). Environment and Climate Change Canada. Guidelines for the assessment of alternatives for mine waste disposal. Mining and Processing Division. 34 p et annexes. Date modified: 2016-12-23.
- El-Rassi, D., Cole, G., and Chartier, D. (2011). Mineral Resource Evaluation Technical Report, Windfall Lake Gold Project, Quebec, for Eagle Hill Exploration Corporation SRK Consulting (Canada) Inc.



- El-Rassi, D., Cole, G., Weiershäuser, L., and Chartier, D. (2012). Mineral Resource Evaluation Technical Report, Windfall Lake Gold Project, Quebec; for Eagle Hill Exploration Corporation. SRK Consulting (Canada) Inc.
- El-Rassi, D., Chartier, D., Weiershäuser, L., Ravenelle J.-F., and Melis, L. (2014). Technical Report for the Windfall Lake Gold Project, Quebec. Report prepared for Eagle Hill Exploration Corporation. SRK Consulting (Canada) Inc. (2014).
- EQA (2022). Environment Quality Act. Québec Official Publisher, Government of Québec, Chapter Q-2. Updated to June 22.
- Fairbairn, H.W. (1940). Rapport préliminaire sur la région du lac Wetetnagami, Territoire d'Abitibi, RP-151.
- Farrel, K. (1998). Drill hole records ATO-98-04 to ATO-98-16, Windfall property, Urban Township, Québec; for Alto Minerals Inc., preliminary copy, 28 p.
- Feneke, M. (1996). Report of line cutting and ground magnetic survey, Urban Project (2430), Urban Township, Chibougamau Mining division, N.T.S. 32 G/4 49°05' N. Lat., 75°44' W. Long., 11 9. GM 54545.
- Fleury-Frenette, K. & Grammatikopoulos, T. (2021). TIMA Gold Search and QEM Data. SGS. Quebec. Project 16159-18–May 2021.
- Frazer, R.J. (1986). Report on diamond drilling performed on the Urban-Barry claims, Urban-Barry Project; for Exploration Kerr Addison Inc., 80 p. GM 45089.
- Gagné and Masson (2013). Un pas en avant! Loi modifiant la Loi sur les mines/ (2013 L.Q., c.32). Retrieved from <https://www.fasken.com/fr/knowledgehub/2013/12/miningbulletin-20131219>
- Gagnon, R. (2005). Drill logs diamond drill holes WG-05-01 à WG-05-03, Windfall property, Urban township; for Murgor Resources Inc.
- Gagnon, R. (2006). Drill logs diamond drill holes WIN-06-86 to WIN-06-111, Windfall property, Urban Township; for Murgor Resources Inc.
- Gaudreault, D. (1987). Rapport de travaux sur la propriété Urban 32G/4; for Ressources Minérales De Montigny Inc., Géologica Groupe conseil, 121 p. GM 46103.
- Gaudreault, D. (1988). Rapport de travaux de sondage, Propriété Urban 32G/4; for Ressources Minérales De Montigny Inc., Géologica Groupe conseil, 112 p. GM 47861.
- Gaumond, C., and Trépanier, S. (2015). Report on the 2015 till sampling program. Osisko Exploration James Bay, 413 p.



- Gaumond, C., Roussel-L'Allier, R., Bouchard, R., and Simard, P. (2016). Report and Recommendations, 2016 Sampling Till Program, Osisko Mining, 16 p.
- GCM Consultants (2022). Étude de faisabilité sur le traitement des eaux du site Windfall de la mine Osisko – Rapport technique ENV0625-1501-00.
- Genivar (2008). Étude hydrogéologique - Site minier de Windfall Lake, Rapport de Genivar à Noront Resources Ltd., Ref.AV106787, March 2008, 65 pages and appendice.
- Geo Data Solutions GDS. Inc. (2017). Final technical report high resolution helicopter-borne magnetic survey, for Osisko Mining Inc., 26 p.
- Geotech Ltd. (2016). Report on a helicopter-borne aeromagnetic geophysical survey, Main A Block, Lebel-sur-Quévillon, 25 p.
- Geotech Ltd. (2017). Report on a helicopter-borne versatile time domain electromagnetic (VTEM plus) and horizontal magnetic gradiometer geophysical survey, Urban-Barry Project, 90 p.
- GESTIM (Gestion des titres miniers), Ministère de l'Énergie et Ressources naturelles, Québec.
https://gestim.mines.gouv.qc.ca/MRN_GestimP_Presentation/ODM02401_ie.aspx
- Girard, T., and Aumond, R. (2018). Report and Recommendations for the 2018 Summer Exploration Program, Urban-Barry Project, James Bay, Québec, 17 p.
- Girard, T., and Roussel-L'Allier, A. (2018). Technical Report and Recommendations 2016-2017 Exploration Program, Urban-Barry Project, James Bay, Québec, 142 p.
- G&T Metallurgical Services Ltd. (2011). Preliminary Assessment of the Eagle Hill Deposit. Internal Report prepared for Eagle Hill Exploration Corporation, August 12, 2011.
- Golder Associates Ltd. (2018). Rock Engineering in Support of PEA Mine Design. Osisko Mining – Windfall Project Preliminary Economic Assessment (PEA). Draft technical report. Ref. no.: GAL062-1897250-RevA. Dated June 2018.
- Golder Associates Ltd. (2020a). Étude hydrogéologique pour le dénoyage de la rampe d'exploration et de son prolongement vers Caribou/27 et des extensions vers les secteurs Lynx et Underdog. GAL019-1774793-3000-RF-Rev0.
- Golder Associates Ltd. (2020b). Climate Parameters for Preliminary Economical Assessment Report – Windfall Project, Québec. Ref. no.: GAL093-20146303-20001-TM-Rev0. Dated December 1, 2020.
- Golder Associates Ltd. (2021). Site Selection Study for the Development of a Tailings Management Facility. GAL099-20146303-20001-RE-Rev0. Dated May 2021.



- Golder Associates Ltd. (2022a). 2021-2022 Geotechnical Investigation at the Tailings Management Facility – Factual Report – Windfall Project, Québec. Ref. no.: GAL116-20146303-20006-R-Rev0.
- Golder Associates Ltd. (2022b). Windfall Project – Filtered Tailings Stack Design Basis Memorandum, Québec. Ref. no.: GAL126-2148985706-MT-Rev0.
- Golder Associates Ltd. (2022c). Site Selection Study for the Development of a Tailings Management Facility, Windfall Project, Québec, no ref.: GAL099-20146303-20001-RevA.
- Golder Associates Ltd. (2022d). Windfall Gold Mine Site Detailed Climate Change Dataset, no ref.: GAL128-2148985706-R-Rev0-05.
- Golder Associates Ltd. (2022e). 2020 Geotechnical Tailings Characterization, Windfall Project, Québec, no ref.: GAL105-20146303-20001-R-RevA.
- Golder Associates Ltd. (2023a). Preliminary TMF Design in Support of the Feasibility Study. Ref. no.: GAL134-2148985706-R-RevA. In preparation.
- Golder Associates Ltd. (2023b). Geochemical Characterization of Ore, Waste Rock and Tailings for the Windfall Lake Project, Quebec. Ref. no.: GAL 137-2148985706-R-RevA. In preparation.
- Golder Associates Ltd. (2023c). Water Management Plan, in Support of the Feasibility Study. Ref. no.: GAL139-2148985706-Water Management Plan. In preparation.
- Golder Associates Ltd. (2023d). Water Balance Model Report, in Support of the Feasibility Study. Ref. no.: GAL138-2148985706-Water Balance Model. In preparation.
- Grenier (2021). Osisko Mining press release, June 15, 2022. Osisko Hits New Discovery One Kilometre North of Windfall.
- Guzun, V. (2012). Mining Rights in the Province of Quebec. Retrieved from <http://www.blakes.com/English/Resources/Bulletins/Pages/Details.aspx?BulletinID=1490>
- Hardie, C., Richard, P.-L., Torrealba, J., Faure, S., St-Laurent, J., Frenette, P., Bratty, M., Dagenais, A.-M., Palmer, P., Gaulin, L., Latulippe, S., Poirier, E. (2018). NI 43-101 Technical Report: Preliminary Economic Assessment of the Windfall Lake Project, Lebel-sur-Quévillon, Québec, Canada. August 1, 2018, 850 p.
- Hardie, C., Athurion, C., Houle, M., Richard, P.-L., St-Onge, N., Langlais, P., Dion St-Pierre, M.-C., Boulianne, Y., Mailloux, M., Laroche, I., Latulippe, S., Poirier, E. (2021). NI 43-101 Technical Report: Preliminary Economic Assessment Update for the Windfall Project. Effective date of April 6, 2021. Report dated April 26, 2021, 594 p.



- Hoek E. (1994). Strength of rock and rock masses. *ISRM News Journal* 1994;2(2):4e16.
- Hoek, E., Kaiser, P.K., Bawden, W.F. (1995). Support of underground excavations in hard rock. Rotterdam: A.A. Balkema; 1995
- INAC (2022). Indigenous and Northern Affairs Canada. First Nation Profiles Interactive Map. Government of Canada. Consulted in September 2022 online: <https://geo.aadnc-aandc.gc.ca/cippn-fnpim/index-eng.html>
- ISQ (2021). Institut de la statistique du Québec. Projection de la population des municipalités de 500 habitants et plus, selon le groupe d'âge, scénario de Référence A2021, 2020-2041.
- ISQ (2022a). Institut de la statistique du Québec. Estimations de la population des MRC, Québec, 1^{er} juillet 1996 à 2021. Consulted in September 2022 online: <https://statistique.quebec.ca/fr/document/population-et-structure-par-age-et-sexe-municipalites-regionales-de-comte-mrc/tableau/estimations-de-la-population-des-mrc>
- ISQ (2022b). Institut de la statistique du Québec. Population et structure par âge et sexe – Municipalités. Consulted in August 2022 online: <https://statistique.quebec.ca/fr/document/population-et-structure-par-age-et-sexe-municipalites>
- Itasca (2019). FLAC3D Version 7.00 - Theory and Background. Published by Itasca Consulting Group, Inc., 176 pp. Minneapolis, MN, USA.
- JBACE (2019) (James Bay Advisory Committee on the Environment). Pratiques exemplaires pour les promoteurs de projets: participation et implication du public dans le cadre de projets dans le territoire de la Baie-James. ISBN: 978-1-9995599-5-3 (PDF). 32 p.
- Joly, M. (1990). Géologie de la région du Lac aux Loutres et du lac Lacroix. Ministère de l'Énergie et des Ressources, Québec ; MB 90-42, 55 p.
- Lambert, G. (1988). Levé géophysique, Projet Urban. For Ressources Maufort Inc. and Shiva Ventures Inc.; Val-d'Or Géophysique Ltée.
- Lambert, G. and Turcotte, R. (1988). Geophysical survey, property of Exploration Kerr Addison Inc., Urban Project, Urban Twp. Québec Province., Val D'Or Géophysique, GM 47140, 11 p.
- Lambert, G. (1999). Memorandum: Levés géophysiques en forage, trous ATO-99-17 à 99-21, Projet Windfall. Report prepared for Inmet Mining, May 26, 1999, 11 p.
- Lambert, G. (2012). Rapport sur des travaux géophysiques au sol: levés de polarisation provoquée; for Eagle Hill Exploration; TMC Geophysique.



- Lambert, G. (2014). Rapport sur des travaux géophysique au sol: Levés Magnétométriques champ total, projet Windfall; for Eagle Hill Exploration by Géosciences, 13 pages including maps.
- Lanthier, G. (2004 and 2005). Drill logs diamond drill holes WIN-04-01 à WIN-04-11 et WIN-05-12 à WIN-05-85, Windfall property, Urban township; for Murgor Resources Inc.
- Lascelles and Samne (2022). Metallurgical testwork on samples from two Lynx zones of the Windfall deposit. SGS. Quebec. Project 16159-11. Final Report – February 2022.
- Lavoie, C. (1996a). Induced polarization survey performed on the property owned by Alto Industries Inc., Windfall property, Urban Township, Qc, 19 p. GM 54734.
- Lavoie, C. (1996b). Induced polarization survey performed on the property owned by Alto Industries Inc., Alcane property, Urban Township, Qc, 20 p. GM 54405.
- Lavoie, C. (1996c). Induced polarization survey performed on the property owned by Freewest Resources Inc. Urban Project (24-30), Urban Township, Qc, 20 p. GM 54544.
- Li & Aubertin (2012). A Modified Solution to Assess the Required Strength of Exposed Backfill in Mine Stopes. *Can Geotech J.*, 49(8), pp. 994-1002.
- Li & Aubertin, (2014). An Improved Method to Assess the Required Strength of Cemented Backfill in Underground Stopes with an Open Face. *Int. J. Mining Sc. and Tech.* 24, pp. 549-558.
- Les Pourvoiries du Québec (2014). [Outfitters; hunting outfitters & fishing outfitters in Quebec, Canada, Québec Outfitter Federation \(pourvoiries.com\)](http://www.pourvoiries.com)
- McLaughlin, M, Kesavanathan, D, Sweeney, D., Hafez, S.A., Chartier D., Couture, J.F, Roy, P., D'Anjou, N., Dion St-Pierre, M.C. (2015). Preliminary Economic Assessment of the Windfall Lake Gold Property, Québec, Canada; for Eagle Hill Exploration Corporation, Tetra Tech, April 28, 2015.
- MAMH (2010). Ministère des Affaires municipales et de l'Habitation. Répertoire des municipalités. Gouvernement régional d'Eeyou Istchee Baie-James. Online: <https://www.mamh.gouv.qc.ca/repertoire-des-municipalites/fiche/municipalite/99060/>
- Mathews, K.E., Hoek, E., Wyllie, D., and Stewart, S.B. (1981). Prediction of Stable Excavation Spans for Mining at Depths Below 1000 meters in Hard Rock, CANMET, DSS Serial No. 0SQ80-00081, DSS File No. 17SQ.23440-0-9020.
- MDELCC (2012). Ministère du Développement durable, Environnement et Lutte contre les Changements climatiques. Directive 019 sur l'industrie minière, mars 2012. 95 p.



- MDDELCC (2015). Ministère du Développement durable, Environnement et Lutte contre les Changements climatiques. Lignes directrices relativement aux niveaux sonores provenant d'un chantier de construction industriel, version du 17 mars 2015. 1 p.
- MDDEP (2012). Ministère du Développement durable, de l'Environnement et des Parcs du Québec. Directive 019 sur l'industrie minière. ISBN: 978-2-550-64507-8 (PDF). 66 pages + appendices.
- MELCC (2020): Ministère de l'Environnement et de la Lutte contre les changements climatiques. Guide de caractérisation des résidus miniers et du minerai, Québec, 52 p.
- MERN (2019). Ministère de l'Énergie et des Ressources naturelles. Native Community Consultation Policy specific to the mining sector. ISBN: 978-2-550-84198-9 (PDF). 21 p.
- MERN (2022). Ministère de l'Énergie et des Ressources naturelles. Guide de préparation du plan de réaménagement et de restauration des sites miniers au Québec. Direction de la restauration des sites miniers, ISBN: 978-2-550-92682-5 (PDF). 2022.
- Mining Act (Bill 70; the "Amending Act"), (2013). National Assembly, First session, Fortieth Legislature Bill 70, Chapter 32.
- Ministre de la justice du Canada (2022) Règlement sur les effluents des mines de métaux et des mines de diamants (REMMMD), dernière modification 24 juin 2022, 76 p.
- Mitchell, R. et al. (1982). Model studies on cemented tailings used in mine backfill. *Canadian Geotechnical Journal* 19 (1982): 14-28.
- Murahwi, C., and Torrealba, J. (2020). An Updated Mineral Resource Estimate for the Windfall Lake Project, Located in the Abitibi Greenstone Belt, Urban Township, Eeyou Istchee James Bay, Québec, Canada". Effective date of January 3, 2020. Micon International Limited for Osisko Mining Inc., Report dated April 3, 2020, 335 p.
- Nguyên, K. (2019). Zone 27 Bulk Sample Processing at Redstone Mill. Osisko Mining Inc. Internal Memo. Sept 25, 2019.
- Nguyên, K. (2020). Lynx Bulk Sample Processing at Redstone Mill. Osisko Mining Inc. Internal Memo. February 5, 2020.
- Osisko Mining Inc. (2018). Osisko Delivers Positive PEA for Windfall Project. Osisko press release, July 17, 2018. Retrieved from <https://www.osiskominig.com/news>
- Osisko Mining Inc. (2019). Osisko Windfall Zone 27 Bulk Sample Returns 8.53 g/t Au Reconciled head grade. Osisko press release, June 11, 2019. Retrieved from <https://www.osiskominig.com/news>



- Osisko Mining Inc. (2021). Osisko Delivers Positive PEA for Windfall Project. Osisko press release, April 26, 2021. Retrieved from <https://www.osiskominig.com/news>
- Osisko Mining Inc. (2021). Osisko Hits New Discovery One Kilometre North of Windfall. Osisko press release, June 15, 2021. Retrieved from <https://www.osiskominig.com/news>
- Osisko Mining Inc. (2021). Osisko Confirms New High-Grade Gold Discovery. Osisko press release, September 14, 2021. Retrieved from <https://www.osiskominig.com/news>
- Osisko Mining Inc. (2022). Osisko Announces Binding Term Sheet with Miyuukaa to Transport Hydroelectric Power to Windfall Project, December 8, 2022. Retrieved from <https://www.osiskominig.com/news>
- Personal communication (2018). Land use interviews with tallymen of W25B and W25A traplines as part of initial consultation activities. Windfall mining project. Summer 2018.
- Plante, L. (1997). Geophysical surveys – IP and Mag, performed on a property owned by Alto Industries Inc., Alcan property, Urban Township, QC, 19 p. GM 56245.
- Plante, L. (1998). Geophysical surveys – HEM, VLF, and MAG for Alto Industries Inc. Windfall property, Urban Township, Qc, 17 p. GM 56450.
- Relevés Géophysique Inc. (1983). Levé aérien par input MK VI – Région de Marin-Barry. Report: DP-83-08.
- Rhéaume, P., and Bandyayera, D. (2006). Révision stratigraphique de la Ceinture d'Urban-Barry: Ministère des Ressources naturelles et de la Faune, Québec, RP 2006-08, 11 p.
- Richard, P.-L., Athurion, C., and Houde, M. (2021). NI 43-101 Technical Report and Mineral Resource Estimate Update for the Windfall Project, Eeyou Istchee James Bay, Québec, Canada. Effective date November 30, 2020. Prepared by BBA inc. for Osisko Mining Inc. Report dated March 8, 2021, 368 p.
- Richard, P.-L., Bélisle, M. (2022). NI 43-101 Technical Report - Mineral Resource Estimate Update for the Windfall Project, Eeyou Istchee James Bay, Québec, Canada. Effective date of October 20, 2021. Prepared by BBA Inc. for Osisko Mining Inc. Report dated February 10, 2022. 353 p.
- Robert, F. (2001). Syenite-associated disseminated gold deposits in the Abitibi greenstone belt, Canada. Mineralium Deposita, 36, 503-516.
- Roy, I., Nguyen, K., St-Laurent, J., Tremblay, L.-M., Grenier, L. (2020a). Advancement Research Report, Zone 27 Bulk Sample, 70 p.



- Roy, I., Nguyen, K., St-Laurent, J., Tremblay, L.-M., Grenier, L. (2020b). Advancement Research Report, Lynx Bulk Sample, 70 p.
- Samne, C. (2018). An Investigation into Metallurgical Test Program on the Windfall Project in Support of Preliminary Economic Assessment Study. SGS. Quebec. Project 16159-001- Final Report May 2018.
- Samne, C. (2019). An Investigation into Metallurgical Test Program on the Windfall Project. SGS. Quebec. Project 16159-001- Phase 3&4.
- SGS Minerals Services. (2020). An Investigation into Gold Department Study on Two Composite Samples from the Windfall Project. Project 16159-11 – Mineralogy Report – Final, December 2020.
- Simard, J. (2014). Rapport sur un levé de polarisation provoquée effectué sur la propriété Rousseau, canton Belmont, Baie James, Québec; for Eagle Hill Exploration by Géophysique TMC. Ref: 14C-153, 25 p.
- Simard, P. (2022). Osisko Mining press release, January 26, 2022. Osisko confirms new high-grade zone at Golden Bear.
- SkyTEM Canada Inc. (2016). Data Report for Oban Mining Corporation, 61 p.
- Sproule, R., and Tuscherer, M. (2016). Report on targeting and field validation in the Urban-Barry belt for Osisko Mining, 87 p.
- Statistics Canada (2016). Census Profile, 2016 Census (statcan.gc.ca)
- Statistics Canada (2017). Profil du recensement. Recensement de 2016. Consulted in September 2022 online: <https://www12.statcan.gc.ca/census-recensement/2016/dp-pd/prof/index.cfm?Lang=F>
- Statistics Canada (2021). Census Profile, 2021 Census of Population, Lebel-sur-Quevillon: <https://www12.statcan.gc.ca/census-recensement/2021/dp-pd/prof/search-recherche/results-resultats.cfm?Lang=E&SearchText=Lebel-sur-Quevillon>
- Statistics Canada (2021). Census Profile, 2021 Census of Population, Chibougamau: <https://www12.statcan.gc.ca/census-recensement/2021/dp-pd/prof/details/page.cfm?Lang=E&SearchText=chibougamau&DGUIDlist=2021A00052499005,2021A00052489040,2021A00052499025&GENDERlist=1,2,3&STATISTIClist=1&HEADERlist=0>



- Statistics Canada (2022). Profil du recensement. Recensement de la population de 2021. Consulted in September 2022 online: <https://www12.statcan.gc.ca/census-recensement/2021/dp-pd/prof/index.cfm?Lang=F>
- St-Laurent, J., Faure, S., Torrealba, J. (2018). NI 43-101 Technical Report and Mineral Resource Estimate for Osisko Mining Inc. on the Windfall Lake Project, Windfall Lake and Urban Barry Properties. Dated June 12, 2018; Effective date of May 14, 2018. InnovExplo. 339 p.
- Stober et Bucher, 2007. Hydraulic properties of crystalline basement. *Hydrogeology Journal* 15: 213-224.
- Thorsen, K. (2004). Exploration report on the 2004 diamond drill program on the Windfall Property, Urban Township; for Fury Exploration Ltd, 14 p.
- Tremblay, R.J. (1999a). Summary report on the Fall 1998 diamond drilling program, DDH ATO-98-09 to ATO-98-11, Windfall property, Urban Township; for Alto Minerals Inc and Noront Resources Ltd, 122 p. GM 56449.
- Tremblay, R.J. (1999b). Summary report on the Fall 1998 diamond drilling program, DDH ATO-98-12 to ATO-98-13, Alcane property, Urban Township; for Alto Minerals Inc and Noront Resources Ltd.
- Tremblay, R.J. (1999c). Drill logs diamond drill holes, ATO-98-14 to ATO-98-16, Alto/Noront project, Urban township; for Alto Minerals Inc/Noront Resources Ltd/Inmet Mining Corporation, 62 p. GM 57412.
- Turcotte, R. (1987). Levé Géophysique Propriété de Ressources DeMontigny Inc. Projet Urban-M, Canton d'Urban, Province de Québec. 12 p. GM44547.
- Turcotte, D. (2011). Assessment Report for Windfall Project, Diamond drilling/Surface mapping report, Urban Township, Abitibi Region, Québec; for Eagle Hill Exploration.
- Yu (1991). Yu, T.R (1991). Mechanisms of Fill Failure and Fill Strength Requirements. Falconbridge Limited, Kidd Creek Division. Timmins, Ontario, Canada.
- Verret, F. (2018). An Investigation into Metallurgical Test Program on the Windfall Project in Support of Preliminary Economic Assessment prepared for Osisko Mining. SGS Canada Inc., Québec City and Lakefield). Project 16159-001.
- Villahermosa, B. (2019). Windfall Project, Canada, Seismic De-Risking Report, Stage 1, 33 p.
- Wilson, V. and Gosselin, M.-C. (2021). Technical Report on the Gladiator, Barry, and Moroy Deposits, and Bachelor Mine, Northwestern Québec, Canada. Prepared for Bonterra Resources Inc. SLR Consulting (Canada) Ltd., Report No. 233.03336.R0000.



- White, M.V. (1998). Report on phase I and II drilling carried out on Windfall/Alcane properties, Urban Township, Québec; for Alto Minerals Inc., 27 p. GM 56448.
- World Meteorological Organization (WMO). 2009b. Manual on Estimation of Probable Maximum Precipitation (PMP). World Meteorological Organization (WMO). WMONo. 1045. Geneva, Switzerland.
- WSP (2022). Étude hydrogéologique pour la mine souterraine du projet Lac Windfall. Étude de faisabilité et d'impact sur l'environnement. Ref. no.: GAL 120-21489857-RF-RevA. Dated October 2022.
- WSP (2022a). Projet Minier Windfall – Investigations géophysiques 2021, Québec. Ref. WSP: 201-11330-29 - Préliminaire.
- WSP (2022b). Rapport d'inspection 2022 – Chemin d'accès et pont Wetetenagami. Projet Windfall
- WSP. 2022 c. Étude géotechnique pour la conception des infrastructures de surface, Rapport géotechnique Factuel - Agrandissement de la halde à stérile, Site minier Windfall, Baie-James. Rapport produit pour Osisko Mining Inc. Réf. WSP: 201-11330-29.
- WSP. 2022 d. Étude géotechnique pour la conception des infrastructures de surface, Rapport géotechnique Factuel - Halde à minerai, Site minier Windfall, Baie-James. Rapport produit pour Osisko Mining Inc. Réf. WSP: 201-11330-29.
- WSP. 2022 e. Étude géotechnique pour la conception des infrastructures de surface, Rapport géotechnique Factuel – Bassin B, Site minier Windfall, Baie-James. Rapport produit pour Osisko Mining Inc. Réf. WSP: 201-11330-29.
- WSP. 2022 f. Étude géotechnique pour la conception des infrastructures de surface, Rapport géotechnique factuel – Bassin C, Site minier Windfall, Baie-James. Rapport produit pour Osisko Mining Inc. Réf. WSP: 201-11330-29.
- WSP. 2022 g. Étude géotechnique pour la conception des infrastructures de surface, Rapport géotechnique factuel – Bassin D, Site minier Windfall, Baie-James. Rapport produit pour Osisko Mining Inc. Réf. WSP: 201-11330-29.
- WSP. 2022 h. Étude géotechnique pour la conception des infrastructures de surface, Rapport géotechnique factuel - Bassin F, Site minier Windfall, Baie-James. Rapport produit pour Osisko Mining Inc. Réf. WSP: 201-11330-29.
- WSP.2022 i. Étude géotechnique pour la conception des infrastructures de surface, Rapport géotechnique Factuel - Bassin J, Site minier Windfall, Baie-James. Rapport produit pour Osisko Mining Inc. Réf. WSP: 201-11330-29.



Osisko Mining Inc.

NI 43-101 – Technical Report

Feasibility Study for the Windfall Project



Zhou, H. and Downing, S. (2017). Gold Department of Four Composite Samples from the Windfall Project, Project 16159-001. SGS Final Report, July 28, 2017.

Zhou, H. and Downing, S. (2018). Gold Department of One Composite Samples from the Windfall Project, Project 16159-001. SGS Draft Report, May 11, 2018.



Appendix A:

List of claims 2022 – Windfall

The following table presents the status of the claims as of October 11, 2022. All claims that have not been renewed are kilometres away from the limit of the Mineral Resource Estimate.



Title	NTS	Area (ha)	Staking Date	Expiration Date	Owner (According to GESTIM)
2611	32G04	56.38	2003-09-25	2024-09-24	Osisko Mining Inc.
2612	32G04	56.38	2003-09-25	2024-09-24	Osisko Mining Inc.
2613	32G04	56.37	2003-09-25	2024-09-24	Osisko Mining Inc.
2614	32G04	56.37	2003-09-25	2024-09-24	Osisko Mining Inc.
2615	32G04	56.37	2003-09-25	2024-09-24	Osisko Mining Inc.
2616	32G04	56.37	2003-09-25	2024-09-24	Osisko Mining Inc.
2619	32G04	56.36	2003-09-25	2024-09-24	Osisko Mining Inc.
2620	32G04	56.36	2003-09-25	2024-09-24	Osisko Mining Inc.
2621	32G04	56.36	2003-09-25	2024-09-24	Osisko Mining Inc.
2622	32G04	56.36	2003-09-25	2024-09-24	Osisko Mining Inc.
2623	32G04	56.36	2003-09-25	2024-09-24	Osisko Mining Inc.
2624	32G04	56.36	2003-09-25	2024-09-24	Osisko Mining Inc.
2625	32G04	56.36	2003-09-25	2024-09-24	Osisko Mining Inc.
1106259	32G04	56.37	2002-12-06	2023-12-05	Osisko Mining Inc.
1106260	32G04	56.36	2002-12-06	2023-12-05	Osisko Mining Inc.
1106261	32G04	56.36	2002-12-06	2023-12-05	Osisko Mining Inc.
1106262	32G04	56.35	2002-12-06	2023-12-05	Osisko Mining Inc.
1106263	32G04	56.35	2002-12-06	2023-12-05	Osisko Mining Inc.
1106264	32G04	56.34	2002-12-06	2023-12-05	Osisko Mining Inc.
1107033	32G04	56.35	2002-12-11	2023-12-10	Osisko Mining Inc.
1107034	32G04	56.35	2002-12-11	2023-12-10	Osisko Mining Inc.
1107035	32G04	56.35	2002-12-11	2023-12-10	Osisko Mining Inc.
1107036	32G04	56.35	2002-12-11	2023-12-10	Osisko Mining Inc.
1107037	32G04	56.35	2002-12-11	2023-12-10	Osisko Mining Inc.
1107038	32G04	56.35	2002-12-11	2023-12-10	Osisko Mining Inc.
1107039	32G04	56.35	2002-12-11	2023-12-10	Osisko Mining Inc.
1107040	32G04	56.35	2002-12-11	2023-12-10	Osisko Mining Inc.
1107041	32G04	56.34	2002-12-11	2023-12-10	Osisko Mining Inc.
1107042	32G04	56.34	2002-12-11	2023-12-10	Osisko Mining Inc.
1107043	32G04	56.34	2002-12-11	2023-12-10	Osisko Mining Inc.
1107044	32G04	56.34	2002-12-11	2023-12-10	Osisko Mining Inc.
1107045	32G04	56.34	2002-12-11	2023-12-10	Osisko Mining Inc.
1107046	32G04	56.34	2002-12-11	2023-12-10	Osisko Mining Inc.
1107047	32G04	56.34	2002-12-11	2023-12-10	Osisko Mining Inc.



Title	NTS	Area (ha)	Staking Date	Expiration Date	Owner (According to GESTIM)
1107048	32G04	56.34	2002-12-11	2023-12-10	Osisko Mining Inc.
1107049	32G04	56.34	2002-12-11	2023-12-10	Osisko Mining Inc.
1107050	32G04	56.34	2002-12-11	2023-12-10	Osisko Mining Inc.
1107051	32G04	56.34	2002-12-11	2023-12-10	Osisko Mining Inc.
1107052	32G04	56.33	2002-12-11	2023-12-10	Osisko Mining Inc.
1107053	32G04	56.33	2002-12-11	2023-12-10	Osisko Mining Inc.
1107054	32G04	56.33	2002-12-11	2023-12-10	Osisko Mining Inc.
1107055	32G04	56.33	2002-12-11	2023-12-10	Osisko Mining Inc.
1107056	32G04	56.33	2002-12-11	2023-12-10	Osisko Mining Inc.
1107057	32G04	56.33	2002-12-11	2023-12-10	Osisko Mining Inc.
1107058	32G04	56.33	2002-12-11	2023-12-10	Osisko Mining Inc.
1107059	32G04	56.33	2002-12-11	2023-12-10	Osisko Mining Inc.
1107060	32G04	56.33	2002-12-11	2023-12-10	Osisko Mining Inc.
1107061	32G04	56.33	2002-12-11	2023-12-10	Osisko Mining Inc.
1107062	32G04	56.33	2002-12-11	2023-12-10	Osisko Mining Inc.
1107063	32G04	56.33	2002-12-11	2023-12-10	Osisko Mining Inc.
1107064	32G04	56.33	2002-12-11	2023-12-10	Osisko Mining Inc.
1107065	32G04	56.33	2002-12-11	2023-12-10	Osisko Mining Inc.
1107066	32G04	56.33	2002-12-11	2023-12-10	Osisko Mining Inc.
1107067	32G04	56.32	2002-12-11	2023-12-10	Osisko Mining Inc.
1107068	32G04	56.32	2002-12-11	2023-12-10	Osisko Mining Inc.
1107069	32G04	56.32	2002-12-11	2023-12-10	Osisko Mining Inc.
1107070	32G04	56.32	2002-12-11	2023-12-10	Osisko Mining Inc.
1107071	32G04	56.32	2002-12-11	2023-12-10	Osisko Mining Inc.
1107072	32G04	56.32	2002-12-11	2023-12-10	Osisko Mining Inc.
1119376	32G04	10.67	2003-05-23	2024-03-05	Osisko Mining Inc.
1119377	32G04	11.15	2003-05-23	2024-03-05	Osisko Mining Inc.
1119378	32G04	3.29	2003-05-23	2024-03-05	Osisko Mining Inc.
1119379	32G04	56.39	2003-05-23	2024-03-05	Osisko Mining Inc.
1119380	32G04	56.39	2003-05-23	2024-03-05	Osisko Mining Inc.
1119381	32G04	45.66	2003-05-23	2024-03-05	Osisko Mining Inc.
1119386	32G04	56.38	2003-05-23	2024-03-05	Osisko Mining Inc.
1119387	32G04	55.18	2003-05-23	2024-03-05	Osisko Mining Inc.
1119388	32G04	27.07	2003-05-23	2024-03-05	Osisko Mining Inc.



Title	NTS	Area (ha)	Staking Date	Expiration Date	Owner (According to GESTIM)
1119389	32G04	27.33	2003-05-23	2024-03-05	Osisko Mining Inc.
1119390	32G04	27.63	2003-05-23	2024-03-05	Osisko Mining Inc.
1119391	32G04	41.61	2003-05-23	2024-03-05	Osisko Mining Inc.
1119392	32G04	56.38	2003-05-23	2024-03-05	Osisko Mining Inc.
1119393	32G04	54.73	2003-05-23	2024-03-05	Osisko Mining Inc.
1119394	32G04	46.55	2003-05-23	2024-03-05	Osisko Mining Inc.
1119395	32G04	46.83	2003-05-23	2024-03-05	Osisko Mining Inc.
1119396	32G04	46.86	2003-05-23	2024-03-05	Osisko Mining Inc.
1119397	32G04	41.71	2003-05-23	2024-03-05	Osisko Mining Inc.
1119398	32G04	56.37	2003-05-23	2024-03-05	Osisko Mining Inc.
1119399	32G04	56.37	2003-05-23	2024-03-05	Osisko Mining Inc.
1119400	32G04	56.37	2003-05-23	2024-03-05	Osisko Mining Inc.
1119401	32G04	56.37	2003-05-23	2024-03-05	Osisko Mining Inc.
1119402	32G04	56.37	2003-05-23	2024-03-05	Osisko Mining Inc.
1119403	32G04	56.37	2003-05-23	2024-03-05	Osisko Mining Inc.
1119404	32G04	56.37	2003-05-23	2024-03-05	Osisko Mining Inc.
1119405	32G04	56.37	2003-05-23	2024-03-05	Osisko Mining Inc.
1119406	32G04	56.37	2003-05-23	2024-03-05	Osisko Mining Inc.
1119407	32G04	56.37	2003-05-23	2024-03-05	Osisko Mining Inc.
1119408	32G04	56.27	2003-05-23	2024-03-05	Osisko Mining Inc.
1119409	32G04	56.18	2003-05-23	2024-03-05	Osisko Mining Inc.
1119410	32G04	56.37	2003-05-23	2024-03-05	Osisko Mining Inc.
1119411	32G04	56.36	2003-05-23	2024-03-05	Osisko Mining Inc.
1119412	32G04	56.36	2003-05-23	2024-03-05	Osisko Mining Inc.
1119413	32G04	56.36	2003-05-23	2024-03-05	Osisko Mining Inc.
1119414	32G04	56.36	2003-05-23	2024-03-05	Osisko Mining Inc.
1119415	32G04	56.36	2003-05-23	2024-03-05	Osisko Mining Inc.
1119416	32G04	56.36	2003-05-23	2024-03-05	Osisko Mining Inc.
1119417	32G04	56.36	2003-05-23	2024-03-05	Osisko Mining Inc.
1119418	32G04	56.36	2003-05-23	2024-03-05	Osisko Mining Inc.
1119419	32G04	56.36	2003-05-23	2024-03-05	Osisko Mining Inc.
1119420	32G04	56.35	2003-05-23	2024-03-05	Osisko Mining Inc.
1119421	32G04	56.35	2003-05-23	2024-03-05	Osisko Mining Inc.
1119422	32G04	56.35	2003-05-23	2024-03-05	Osisko Mining Inc.



Title	NTS	Area (ha)	Staking Date	Expiration Date	Owner (According to GESTIM)
1119423	32G04	56.35	2003-05-23	2024-03-05	Osisko Mining Inc.
1119424	32G04	56.35	2003-05-23	2024-03-05	Osisko Mining Inc.
1119425	32G04	56.35	2003-05-23	2024-03-05	Osisko Mining Inc.
1119426	32G04	56.35	2003-05-23	2024-03-05	Osisko Mining Inc.
1119427	32G04	56.34	2003-05-23	2024-03-05	Osisko Mining Inc.
1119428	32G04	56.34	2003-05-23	2024-03-05	Osisko Mining Inc.
1119429	32G04	56.34	2003-05-23	2024-03-05	Osisko Mining Inc.
1119430	32G04	56.34	2003-05-23	2024-03-05	Osisko Mining Inc.
1125116	32G04	22.76	2003-07-02	2023-12-04	Osisko Mining Inc.
1125117	32G04	56.39	2003-07-02	2023-12-04	Osisko Mining Inc.
1125118	32G04	56.39	2003-07-02	2023-12-04	Osisko Mining Inc.
1125120	32G04	56.38	2003-07-02	2023-12-04	Osisko Mining Inc.
1125121	32G04	56.38	2003-07-02	2023-12-04	Osisko Mining Inc.
1125122	32G04	56.38	2003-07-02	2023-12-04	Osisko Mining Inc.
1125124	32G04	56.37	2003-07-02	2023-12-04	Osisko Mining Inc.
1126615	32G04	56.37	2003-06-11	2024-06-10	Osisko Mining Inc.
1126616	32G04	56.37	2003-06-11	2024-06-10	Osisko Mining Inc.
1126617	32G04	56.37	2003-06-11	2024-06-10	Osisko Mining Inc.
1126618	32G04	56.36	2003-06-11	2024-06-10	Osisko Mining Inc.
1126619	32G04	56.36	2003-06-11	2024-06-10	Osisko Mining Inc.
1126620	32G04	56.36	2003-06-11	2024-06-10	Osisko Mining Inc.
1126621	32G04	56.36	2003-06-11	2024-06-10	Osisko Mining Inc.
1126622	32G04	56.36	2003-06-11	2024-06-10	Osisko Mining Inc.
1126623	32G04	56.35	2003-06-11	2024-06-10	Osisko Mining Inc.
1126624	32G04	56.35	2003-06-11	2024-06-10	Osisko Mining Inc.
1126625	32G04	56.35	2003-06-11	2024-06-10	Osisko Mining Inc.
1126626	32G04	56.35	2003-06-11	2024-06-10	Osisko Mining Inc.
1126627	32G04	56.35	2003-06-11	2024-06-10	Osisko Mining Inc.
1126628	32G04	56.35	2003-06-11	2024-06-10	Osisko Mining Inc.
1126629	32G04	56.34	2003-06-11	2024-06-10	Osisko Mining Inc.
1126630	32G04	56.34	2003-06-11	2024-06-10	Osisko Mining Inc.
1126631	32G04	56.34	2003-06-11	2024-06-10	Osisko Mining Inc.
1126632	32G04	56.34	2003-06-11	2024-06-10	Osisko Mining Inc.
1126633	32G04	56.34	2003-06-11	2024-06-10	Osisko Mining Inc.



Title	NTS	Area (ha)	Staking Date	Expiration Date	Owner (According to GESTIM)
1126634	32G04	56.34	2003-06-11	2024-06-10	Osisko Mining Inc.
1126635	32G04	56.34	2003-06-11	2024-06-10	Osisko Mining Inc.
1126636	32G04	56.33	2003-06-11	2024-06-10	Osisko Mining Inc.
1126637	32G04	56.33	2003-06-11	2024-06-10	Osisko Mining Inc.
1126638	32G04	56.33	2003-06-11	2024-06-10	Osisko Mining Inc.
1126639	32G04	56.33	2003-06-11	2024-06-10	Osisko Mining Inc.
1126640	32G04	56.33	2003-06-11	2024-06-10	Osisko Mining Inc.
1126641	32G04	56.33	2003-06-11	2024-06-10	Osisko Mining Inc.
1126642	32G04	56.33	2003-06-11	2024-06-10	Osisko Mining Inc.
1126643	32G04	56.33	2003-06-11	2024-06-10	Osisko Mining Inc.
1133001	32G04	56.38	2005-07-11	2024-03-05	Osisko Mining Inc.
2225915	32G03	56.39	2010-05-03	2023-05-02	Osisko Mining Inc.
2225916	32G03	56.39	2010-05-03	2023-05-02	Osisko Mining Inc.
2225917	32G03	56.38	2010-05-03	2023-05-02	Osisko Mining Inc.
2225918	32G03	56.38	2010-05-03	2023-05-02	Osisko Mining Inc.
2225919	32G03	56.37	2010-05-03	2023-05-02	Osisko Mining Inc.
2225920	32G03	56.37	2010-05-03	2023-05-02	Osisko Mining Inc.
2225921	32G03	56.36	2010-05-03	2023-05-02	Osisko Mining Inc.
2225922	32G03	56.36	2010-05-03	2023-05-02	Osisko Mining Inc.
2225923	32G04	56.38	2010-05-03	2023-05-02	Osisko Mining Inc.
2225924	32G04	56.37	2010-05-03	2023-05-02	Osisko Mining Inc.
2225925	32G04	56.36	2010-05-03	2023-05-02	Osisko Mining Inc.
2226346	32G04	56.38	2010-05-04	2023-05-03	Osisko Mining Inc.
2226347	32G04	56.38	2010-05-04	2023-05-03	Osisko Mining Inc.
2226348	32G04	56.37	2010-05-04	2023-05-03	Osisko Mining Inc.
2226349	32G04	56.37	2010-05-04	2023-05-03	Osisko Mining Inc.
2226350	32G04	56.37	2010-05-04	2023-05-03	Osisko Mining Inc.
2226351	32G04	56.37	2010-05-04	2023-05-03	Osisko Mining Inc.
2226352	32G04	56.37	2010-05-04	2023-05-03	Osisko Mining Inc.
2360634	32G04	56.33	2012-08-15	2023-08-14	Osisko Mining Inc.
2360635	32G04	56.33	2012-08-15	2023-08-14	Osisko Mining Inc.
2360636	32G04	56.33	2012-08-15	2023-08-14	Osisko Mining Inc.
2360637	32G04	56.33	2012-08-15	2023-08-14	Osisko Mining Inc.
2360638	32G04	56.33	2012-08-15	2023-08-14	Osisko Mining Inc.



Title	NTS	Area (ha)	Staking Date	Expiration Date	Owner (According to GESTIM)
2371957	32G04	6.05	2013-01-21	2023-08-02	Osisko Mining Inc.
2371958	32G04	11.17	2013-01-21	2023-08-02	Osisko Mining Inc.
2371959	32G04	3.75	2013-01-21	2023-08-02	Osisko Mining Inc.
2371960	32G04	5.22	2013-01-21	2023-08-02	Osisko Mining Inc.
2372910	32G04	28.34	2013-01-21	2023-08-02	Osisko Mining Inc.
2372911	32G04	3.72	2013-01-21	2023-08-02	Osisko Mining Inc.
2372912	32G04	3.36	2013-01-21	2023-08-02	Osisko Mining Inc.
2372913	32G04	3.00	2013-01-21	2023-08-02	Osisko Mining Inc.
2372914	32G04	1.60	2013-01-21	2023-08-02	Osisko Mining Inc.
2376794	32G04	12.38	2013-03-04	2023-08-02	Osisko Mining Inc.
2376795	32G04	47.15	2013-03-04	2023-08-02	Osisko Mining Inc.
2376796	32G04	6.88	2013-03-04	2023-08-02	Osisko Mining Inc.
2376797	32G04	15.53	2013-03-04	2023-08-02	Osisko Mining Inc.
2376841	32G04	9.08	2013-03-11	2023-01-22	Osisko Mining Inc.
2376842	32G04	15.06	2013-03-11	2023-01-22	Osisko Mining Inc.
2376843	32G04	21.71	2013-03-11	2023-01-22	Osisko Mining Inc.
2376844	32G04	27.22	2013-03-11	2023-01-22	Osisko Mining Inc.
2376845	32G04	1.51	2013-03-11	2023-01-22	Osisko Mining Inc.
2376846	32G04	1.90	2013-03-11	2023-01-22	Osisko Mining Inc.
2376847	32G04	56.44	2013-03-11	2023-09-25	Osisko Mining Inc.
2376848	32G04	56.44	2013-03-11	2023-09-25	Osisko Mining Inc.
2376849	32G04	56.43	2013-03-11	2023-09-25	Osisko Mining Inc.
2376850	32G04	56.43	2013-03-11	2023-09-25	Osisko Mining Inc.
2376851	32G04	56.43	2013-03-11	2023-09-25	Osisko Mining Inc.
2376852	32G04	56.43	2013-03-11	2023-09-25	Osisko Mining Inc.
2376853	32G04	56.42	2013-03-11	2023-09-25	Osisko Mining Inc.
2376854	32G04	56.42	2013-03-11	2023-09-25	Osisko Mining Inc.
2376855	32G04	56.42	2013-03-11	2023-09-25	Osisko Mining Inc.
2376856	32G04	56.42	2013-03-11	2023-09-25	Osisko Mining Inc.
2376857	32G04	56.41	2013-03-11	2023-09-25	Osisko Mining Inc.
2376858	32G04	56.41	2013-03-11	2023-09-25	Osisko Mining Inc.
2376859	32G04	56.41	2013-03-11	2023-09-25	Osisko Mining Inc.
2376860	32G04	56.41	2013-03-11	2023-09-25	Osisko Mining Inc.
2376861	32G04	56.40	2013-03-11	2023-09-25	Osisko Mining Inc.



Title	NTS	Area (ha)	Staking Date	Expiration Date	Owner (According to GESTIM)
2376862	32G04	56.40	2013-03-11	2023-09-25	Osisko Mining Inc.
2376863	32G04	56.40	2013-03-11	2023-09-25	Osisko Mining Inc.
2376864	32G04	56.40	2013-03-11	2023-09-25	Osisko Mining Inc.
2376865	32G04	56.44	2013-03-11	2023-09-25	Osisko Mining Inc.
2376866	32G04	56.40	2013-03-11	2023-09-25	Osisko Mining Inc.
2376867	32G04	0.01	2013-03-11	2023-09-25	Osisko Mining Inc.
2376868	32G04	9.56	2013-03-11	2023-09-25	Osisko Mining Inc.
2376869	32G04	34.34	2013-03-11	2023-09-25	Osisko Mining Inc.
2376870	32G04	44.73	2013-03-11	2023-09-25	Osisko Mining Inc.
2376871	32G04	5.93	2013-03-11	2023-09-25	Osisko Mining Inc.
2376872	32G04	30.09	2013-03-11	2023-09-25	Osisko Mining Inc.
2376873	32G04	51.10	2013-03-11	2023-09-25	Osisko Mining Inc.
2376874	32G04	24.57	2013-03-11	2023-09-25	Osisko Mining Inc.
2376875	32G04	6.49	2013-03-11	2023-09-25	Osisko Mining Inc.
2376876	32G04	51.45	2013-03-11	2023-09-25	Osisko Mining Inc.
2376877	32G04	6.15	2013-03-11	2023-09-25	Osisko Mining Inc.
2376878	32G04	23.36	2013-03-11	2023-09-25	Osisko Mining Inc.
2376879	32G04	4.55	2013-03-11	2023-09-25	Osisko Mining Inc.
2376880	32G04	22.22	2013-03-11	2023-09-25	Osisko Mining Inc.
2376881	32G04	43.10	2013-03-11	2023-09-25	Osisko Mining Inc.
2376882	32G04	55.34	2013-03-11	2023-09-25	Osisko Mining Inc.
2376883	32G04	13.53	2013-03-11	2023-09-25	Osisko Mining Inc.
2376884	32G04	51.13	2013-03-11	2023-09-25	Osisko Mining Inc.
2376885	32G04	51.60	2013-03-11	2023-09-25	Osisko Mining Inc.
2376886	32G04	1.57	2013-03-11	2023-09-25	Osisko Mining Inc.
2376887	32G04	47.91	2013-03-11	2023-09-25	Osisko Mining Inc.
2376888	32G04	9.53	2013-03-11	2023-09-25	Osisko Mining Inc.
2376889	32G04	1.60	2013-03-11	2023-09-25	Osisko Mining Inc.
2376890	32G04	31.91	2013-03-11	2023-09-25	Osisko Mining Inc.
2376891	32G04	4.21	2013-03-11	2023-09-25	Osisko Mining Inc.
2376892	32G04	8.15	2013-03-11	2023-09-25	Osisko Mining Inc.
2376893	32G04	5.86	2013-03-11	2023-09-25	Osisko Mining Inc.
2376894	32G04	3.56	2013-03-11	2023-09-25	Osisko Mining Inc.
2376895	32G04	20.80	2013-03-11	2023-09-25	Osisko Mining Inc.



Title	NTS	Area (ha)	Staking Date	Expiration Date	Owner (According to GESTIM)
2376896	32G04	1.83	2013-03-11	2023-09-25	Osisko Mining Inc.
2379285	32G04	56.40	2013-03-25	2023-12-04	Osisko Mining Inc.
2379286	32G04	56.40	2013-03-25	2023-12-04	Osisko Mining Inc.
2379287	32G04	10.28	2013-03-25	2023-12-04	Osisko Mining Inc.
2379288	32G04	21.50	2013-03-25	2023-12-04	Osisko Mining Inc.
2379289	32G04	28.59	2013-03-25	2023-12-04	Osisko Mining Inc.
2379290	32G04	29.19	2013-03-25	2023-12-04	Osisko Mining Inc.
2379291	32G04	6.03	2013-03-25	2023-12-04	Osisko Mining Inc.
2379292	32G04	9.41	2013-03-25	2023-12-04	Osisko Mining Inc.
2379293	32G04	15.90	2013-03-25	2024-03-20	Osisko Mining Inc.
2379294	32G04	34.77	2013-03-25	2024-03-20	Osisko Mining Inc.
2379295	32G04	48.16	2013-03-25	2024-03-20	Osisko Mining Inc.
2379296	32G04	35.65	2013-03-25	2024-03-20	Osisko Mining Inc.
2379297	32G04	33.48	2013-03-25	2024-03-20	Osisko Mining Inc.
2379298	32G04	35.68	2013-03-25	2024-03-20	Osisko Mining Inc.
2379299	32G04	25.16	2013-03-25	2024-03-20	Osisko Mining Inc.
2379300	32G04	19.83	2013-03-25	2024-03-20	Osisko Mining Inc.
2379301	32G04	25.43	2013-03-25	2024-03-20	Osisko Mining Inc.
2379355	32G04	10.73	2013-03-25	2024-03-10	Osisko Mining Inc.
2379356	32G04	1.20	2013-03-25	2024-03-10	Osisko Mining Inc.
2379357	32G04	29.31	2013-03-25	2024-03-10	Osisko Mining Inc.
2379358	32G04	29.05	2013-03-25	2024-03-10	Osisko Mining Inc.
2379359	32G04	28.75	2013-03-25	2024-03-10	Osisko Mining Inc.
2379360	32G04	14.77	2013-03-25	2024-03-10	Osisko Mining Inc.
2379361	32G04	1.65	2013-03-25	2024-03-10	Osisko Mining Inc.
2379362	32G04	9.83	2013-03-25	2024-03-10	Osisko Mining Inc.
2379363	32G04	9.55	2013-03-25	2024-03-10	Osisko Mining Inc.
2379364	32G04	9.52	2013-03-25	2024-03-10	Osisko Mining Inc.
2379365	32G04	14.67	2013-03-25	2024-03-10	Osisko Mining Inc.
2379366	32G04	0.10	2013-03-25	2024-03-10	Osisko Mining Inc.
2379367	32G04	30.39	2013-03-25	2024-03-10	Osisko Mining Inc.
2379368	32G04	38.76	2013-03-25	2024-03-10	Osisko Mining Inc.
2379369	32G04	46.96	2013-03-25	2024-03-10	Osisko Mining Inc.
2379370	32G04	33.04	2013-03-25	2024-03-10	Osisko Mining Inc.



Title	NTS	Area (ha)	Staking Date	Expiration Date	Owner (According to GESTIM)
2379371	32G04	51.84	2013-03-25	2024-03-10	Osisko Mining Inc.
2379372	32G04	34.17	2013-03-25	2024-03-10	Osisko Mining Inc.
2379373	32G04	42.85	2013-03-25	2024-03-10	Osisko Mining Inc.
2379374	32G04	54.79	2013-03-25	2024-03-10	Osisko Mining Inc.
2379375	32G04	52.18	2013-03-25	2024-03-10	Osisko Mining Inc.
2379376	32G04	50.53	2013-03-25	2024-03-10	Osisko Mining Inc.
2379377	32G04	37.09	2013-03-25	2024-03-10	Osisko Mining Inc.
2379378	32G04	26.00	2013-03-25	2024-03-10	Osisko Mining Inc.
2379379	32G04	25.99	2013-03-25	2024-03-10	Osisko Mining Inc.
2379380	32G04	16.99	2013-03-25	2024-03-10	Osisko Mining Inc.
2379381	32G04	2.33	2013-03-25	2024-03-10	Osisko Mining Inc.
2379382	32G04	9.23	2013-03-25	2024-03-10	Osisko Mining Inc.
2379383	32G04	0.19	2013-03-25	2024-03-10	Osisko Mining Inc.
2499652	32G04	56.37	2017-08-11	2024-08-10	Osisko Mining Inc.



Appendix B:

List of claims 2022 – Urban-Barry

The following table presents the status of the claims as of October 11, 2022. All claims that have not been renewed are kilometres away from the limit of the Mineral Resource Estimate.



Title	NTS	Area (ha)	Staking Date	Expiration Date	Owner (According to GESTIM)
2360749	32G04	56,42	2012-09-04	2023-12-31	Osisko Mining Inc.
2360750	32G04	56,42	2012-09-04	2023-12-31	Osisko Mining Inc.
2360751	32G04	56,41	2012-09-04	2023-12-31	Osisko Mining Inc.
2360752	32G04	56,42	2012-09-04	2023-12-31	Osisko Mining Inc.
2360753	32G04	56,41	2012-09-04	2023-12-31	Osisko Mining Inc.
2360754	32G04	7,56	2012-09-04	2023-12-31	Osisko Mining Inc.
2360755	32G04	56,43	2012-09-04	2023-12-31	Osisko Mining Inc.
2360756	32G04	56,42	2012-09-04	2023-12-31	Osisko Mining Inc.
2360757	32G04	56,41	2012-09-04	2023-12-31	Osisko Mining Inc.
2360758	32G04	36,80	2012-09-04	2023-12-31	Osisko Mining Inc.
2360759	32G04	55,13	2012-09-04	2023-12-31	Osisko Mining Inc.
2360760	32G04	56,41	2012-09-04	2023-12-31	Osisko Mining Inc.
2360761	32G04	49,18	2012-09-04	2023-12-31	Osisko Mining Inc.
2360762	32G04	18,71	2012-09-04	2023-12-31	Osisko Mining Inc.
2360763	32G04	14,87	2012-09-04	2023-12-31	Osisko Mining Inc.
2360764	32G04	52,03	2012-09-04	2023-12-31	Osisko Mining Inc.
2360765	32G04	54,94	2012-09-04	2023-12-31	Osisko Mining Inc.
2360766	32G04	14,33	2012-09-04	2023-12-31	Osisko Mining Inc.
2360767	32G04	1,75	2012-09-04	2023-12-31	Osisko Mining Inc.
2360768	32G04	41,99	2012-09-04	2023-12-31	Osisko Mining Inc.
2360769	32G04	46,80	2012-09-04	2023-12-31	Osisko Mining Inc.
2360794	32B13	4,94	2012-09-04	2023-11-22	Osisko Mining Inc.
2360795	32B13	25,52	2012-09-04	2023-11-22	Osisko Mining Inc.
2360796	32B13	8,64	2012-09-04	2023-11-22	Osisko Mining Inc.
2360797	32B13	53,78	2012-09-04	2023-11-22	Osisko Mining Inc.
2360798	32B13	9,79	2012-09-04	2023-11-22	Osisko Mining Inc.
2360799	32B13	6,45	2012-09-04	2023-11-22	Osisko Mining Inc.
2360800	32B13	42,51	2012-09-04	2023-11-22	Osisko Mining Inc.
2360801	32B13	9,90	2012-09-04	2023-11-22	Osisko Mining Inc.
2360802	32B13	56,53	2012-09-04	2023-01-13	Osisko Mining Inc.
2360803	32B13	56,52	2012-09-04	2023-01-13	Osisko Mining Inc.
2360804	32B13	56,52	2012-09-04	2023-01-13	Osisko Mining Inc.
2360805	32B13	56,51	2012-09-04	2023-01-13	Osisko Mining Inc.
2360806	32B13	56,51	2012-09-04	2023-01-13	Osisko Mining Inc.
2360807	32B13	56,53	2012-09-04	2023-01-13	Osisko Mining Inc.
2360808	32B13	56,54	2012-09-04	2023-01-13	Osisko Mining Inc.
2360809	32B13	56,54	2012-09-04	2023-01-13	Osisko Mining Inc.



Title	NTS	Area (ha)	Staking Date	Expiration Date	Owner (According to GESTIM)
2360810	32B13	55,44	2012-09-04	2023-01-13	Osisko Mining Inc.
2360811	32B13	4,76	2012-09-04	2023-01-13	Osisko Mining Inc.
2360812	32B13	21,16	2012-09-04	2023-01-13	Osisko Mining Inc.
2360813	32B13	54,45	2012-09-04	2023-01-13	Osisko Mining Inc.
2364938	32B13	56,53	2012-10-23	2024-07-30	Osisko Mining Inc.
2364939	32B13	56,53	2012-10-23	2024-07-30	Osisko Mining Inc.
2364940	32B13	56,52	2012-10-23	2024-07-30	Osisko Mining Inc.
2364941	32B13	56,52	2012-10-23	2024-07-30	Osisko Mining Inc.
2364942	32B13	56,51	2012-10-23	2024-07-30	Osisko Mining Inc.
2364943	32B13	51,77	2012-10-23	2024-07-30	Osisko Mining Inc.
2364944	32B13	4,97	2012-10-23	2024-07-30	Osisko Mining Inc.
2364945	32B13	1,10	2012-10-23	2024-07-30	Osisko Mining Inc.
2364946	32B13	23,98	2012-10-23	2024-07-30	Osisko Mining Inc.
2364947	32B13	2,09	2012-10-23	2024-07-30	Osisko Mining Inc.
2364948	32B13	56,54	2012-10-23	2024-07-30	Osisko Mining Inc.
2364949	32B13	16,65	2012-10-23	2024-07-30	Osisko Mining Inc.
2364950	32B13	56,54	2012-10-23	2024-07-30	Osisko Mining Inc.
2364951	32B13	56,53	2012-10-23	2024-07-30	Osisko Mining Inc.
2364952	32B13	33,04	2012-10-23	2024-07-30	Osisko Mining Inc.
2364953	32B13	3,63	2012-10-23	2024-07-30	Osisko Mining Inc.
2364954	32B13	56,53	2012-10-23	2024-07-30	Osisko Mining Inc.
2364955	32B13	14,78	2012-10-23	2024-07-30	Osisko Mining Inc.
2364956	32B13	56,53	2012-10-23	2024-07-30	Osisko Mining Inc.
2364957	32B13	18,35	2012-10-23	2024-07-30	Osisko Mining Inc.
2364958	32B13	56,53	2012-10-23	2024-07-30	Osisko Mining Inc.
2364959	32B13	56,52	2012-10-23	2024-07-30	Osisko Mining Inc.
2364960	32B13	48,02	2012-10-23	2024-07-30	Osisko Mining Inc.
2364961	32B13	2,91	2012-10-23	2024-07-30	Osisko Mining Inc.
2364962	32B13	56,52	2012-10-23	2024-07-30	Osisko Mining Inc.
2364963	32B13	9,72	2012-10-23	2024-07-30	Osisko Mining Inc.
2364964	32B13	56,52	2012-10-23	2024-07-30	Osisko Mining Inc.
2364965	32B13	56,51	2012-10-23	2024-07-30	Osisko Mining Inc.
2364966	32B13	30,69	2012-10-23	2024-07-30	Osisko Mining Inc.
2364967	32B13	33,19	2012-10-23	2024-07-30	Osisko Mining Inc.
2364968	32B13	49,76	2012-10-23	2024-07-30	Osisko Mining Inc.
2364969	32B13	49,48	2012-10-23	2024-07-30	Osisko Mining Inc.
2364970	32B13	44,42	2012-10-23	2024-07-30	Osisko Mining Inc.



Title	NTS	Area (ha)	Staking Date	Expiration Date	Owner (According to GESTIM)
2369488	32G04	0,01	2012-12-03	2023-07-12	Osisko Mining Inc.
2369489	32G04	1,07	2012-12-03	2023-07-12	Osisko Mining Inc.
2369490	32G04	0,11	2012-12-03	2023-07-12	Osisko Mining Inc.
2369491	32G04	8,49	2012-12-03	2023-07-12	Osisko Mining Inc.
2369492	32G04	0,04	2012-12-03	2023-07-12	Osisko Mining Inc.
2369493	32G04	8,51	2012-12-03	2023-07-12	Osisko Mining Inc.
2369494	32G04	0,01	2012-12-03	2023-07-12	Osisko Mining Inc.
2369495	32G04	0,09	2012-12-03	2023-07-12	Osisko Mining Inc.
2369713	32G04	56,40	2012-12-03	2024-08-08	Osisko Mining Inc.
2369714	32G04	56,40	2012-12-03	2024-08-08	Osisko Mining Inc.
2369715	32G04	56,39	2012-12-03	2024-08-08	Osisko Mining Inc.
2369716	32G04	56,40	2012-12-03	2024-08-08	Osisko Mining Inc.
2369717	32G04	28,05	2012-12-03	2024-08-08	Osisko Mining Inc.
2369718	32G04	7,22	2012-12-03	2024-08-08	Osisko Mining Inc.
2369719	32G04	52,67	2012-12-03	2024-08-08	Osisko Mining Inc.
2369720	32G04	1,47	2012-12-03	2024-08-08	Osisko Mining Inc.
2369721	32G04	42,07	2012-12-03	2024-08-08	Osisko Mining Inc.
2369722	32G04	53,03	2012-12-03	2024-08-08	Osisko Mining Inc.
2369723	32G04	3,42	2012-12-03	2024-08-08	Osisko Mining Inc.
2369724	32G04	11,30	2012-12-03	2024-08-08	Osisko Mining Inc.
2369725	32G04	53,39	2012-12-03	2024-08-08	Osisko Mining Inc.
2369726	32G04	12,64	2012-12-03	2024-08-08	Osisko Mining Inc.
2369727	32G04	34,89	2012-12-03	2024-08-08	Osisko Mining Inc.
2369728	32G04	32,03	2012-12-03	2024-08-08	Osisko Mining Inc.
2376832	32G04	56,40	2013-02-27	2024-03-20	Osisko Mining Inc.
2376833	32G04	19,37	2013-02-27	2024-03-20	Osisko Mining Inc.
2376834	32G04	35,60	2013-02-27	2024-03-20	Osisko Mining Inc.
2376835	32G04	17,48	2013-02-27	2024-03-20	Osisko Mining Inc.
2376836	32G04	31,24	2013-02-27	2024-03-20	Osisko Mining Inc.
2376837	32G04	30,38	2013-02-27	2024-03-20	Osisko Mining Inc.
2376838	32G04	28,86	2013-02-27	2024-03-20	Osisko Mining Inc.
2376839	32G04	52,34	2013-02-27	2024-03-20	Osisko Mining Inc.
2376840	32G04	27,03	2013-02-27	2024-03-20	Osisko Mining Inc.
2387601	32G04	56,43	2013-07-18	2023-11-10	Osisko Mining Inc.
2387602	32G04	56,43	2013-07-18	2023-11-10	Osisko Mining Inc.
2387612	32G04	56,43	2013-07-18	2023-11-10	Osisko Mining Inc.
2387613	32G04	56,43	2013-07-18	2023-11-10	Osisko Mining Inc.



Title	NTS	Area (ha)	Staking Date	Expiration Date	Owner (According to GESTIM)
2387614	32G04	56,43	2013-07-18	2023-11-10	Osisko Mining Inc.
2387615	32G04	56,43	2013-07-18	2023-11-10	Osisko Mining Inc.
2387616	32G04	56,43	2013-07-18	2023-11-10	Osisko Mining Inc.
2387617	32G04	56,43	2013-07-18	2023-11-10	Osisko Mining Inc.
2387618	32G04	56,43	2013-07-18	2023-11-10	Osisko Mining Inc.
2387619	32G04	56,43	2013-07-18	2023-11-10	Osisko Mining Inc.
2387626	32G04	56,42	2013-07-18	2023-11-10	Osisko Mining Inc.
2387627	32G04	56,42	2013-07-18	2023-11-10	Osisko Mining Inc.
2387628	32G04	56,42	2013-07-18	2023-11-10	Osisko Mining Inc.
2387629	32G04	56,42	2013-07-18	2023-11-10	Osisko Mining Inc.
2387630	32G04	56,42	2013-07-18	2023-11-10	Osisko Mining Inc.
2387631	32G04	56,42	2013-07-18	2023-11-10	Osisko Mining Inc.
2387632	32G04	56,42	2013-07-18	2023-11-10	Osisko Mining Inc.
2387635	32G04	56,41	2013-07-18	2023-11-10	Osisko Mining Inc.
2387636	32G04	56,41	2013-07-18	2023-11-10	Osisko Mining Inc.
2387637	32G04	56,41	2013-07-18	2023-11-10	Osisko Mining Inc.
2387638	32G04	56,41	2013-07-18	2023-11-10	Osisko Mining Inc.
2387639	32G04	56,41	2013-07-18	2023-11-10	Osisko Mining Inc.
2387640	32G04	56,41	2013-07-18	2023-11-10	Osisko Mining Inc.
2387641	32G04	56,41	2013-07-18	2023-11-10	Osisko Mining Inc.
2387642	32G04	56,41	2013-07-18	2023-11-10	Osisko Mining Inc.
2387643	32G04	56,40	2013-07-18	2023-11-10	Osisko Mining Inc.
2387644	32G04	56,40	2013-07-18	2023-11-10	Osisko Mining Inc.
2387645	32G04	56,40	2013-07-18	2023-11-10	Osisko Mining Inc.
2387646	32G04	56,40	2013-07-18	2023-11-10	Osisko Mining Inc.
2387647	32G04	56,39	2013-07-18	2023-11-10	Osisko Mining Inc.
2387648	32G04	56,39	2013-07-18	2023-11-10	Osisko Mining Inc.
2387649	32G04	56,39	2013-07-18	2023-11-10	Osisko Mining Inc.
2387654	32G04	56,41	2013-07-18	2023-11-10	Osisko Mining Inc.
2387655	32G04	56,40	2013-07-18	2023-11-10	Osisko Mining Inc.
2387657	32G04	56,43	2013-07-18	2023-11-10	Osisko Mining Inc.
2387658	32G04	56,40	2013-07-18	2023-11-10	Osisko Mining Inc.
2387659	32G04	56,40	2013-07-18	2023-11-10	Osisko Mining Inc.
2387661	32G04	4,83	2013-07-18	2023-11-10	Osisko Mining Inc.
2387662	32G04	56,38	2013-07-18	2023-11-10	Osisko Mining Inc.
2387664	32G04	56,41	2013-07-18	2023-11-10	Osisko Mining Inc.
2387665	32G04	56,39	2013-07-18	2023-11-10	Osisko Mining Inc.



Title	NTS	Area (ha)	Staking Date	Expiration Date	Owner (According to GESTIM)
2387666	32G04	3,37	2013-07-18	2023-11-10	Osisko Mining Inc.
2387667	32G04	56,38	2013-07-18	2023-11-10	Osisko Mining Inc.
2387671	32G04	41,68	2013-07-18	2023-11-10	Osisko Mining Inc.
2387672	32G04	39,39	2013-07-18	2023-11-10	Osisko Mining Inc.
2387673	32G04	0,08	2013-07-18	2023-11-10	Osisko Mining Inc.
2387675	32G04	56,38	2013-07-18	2023-11-10	Osisko Mining Inc.
2387677	32G04	56,38	2013-07-18	2023-11-10	Osisko Mining Inc.
2387678	32G04	2,11	2013-07-18	2023-11-10	Osisko Mining Inc.
2387681	32G04	56,37	2013-07-18	2023-11-10	Osisko Mining Inc.
2387682	32G04	56,40	2013-07-18	2023-11-10	Osisko Mining Inc.
2387685	32G04	5,30	2013-07-18	2023-11-10	Osisko Mining Inc.
2387687	32G04	40,85	2013-07-18	2023-11-10	Osisko Mining Inc.
2387690	32G04	49,51	2013-07-18	2023-11-10	Osisko Mining Inc.
2387692	32G04	56,40	2013-07-18	2023-11-10	Osisko Mining Inc.
2387699	32G04	45,22	2013-07-18	2023-11-10	Osisko Mining Inc.
2387701	32G04	20,74	2013-07-18	2023-11-10	Osisko Mining Inc.
2387702	32G04	13,32	2013-07-18	2023-11-10	Osisko Mining Inc.
2387703	32G04	20,76	2013-07-18	2023-11-10	Osisko Mining Inc.
2387704	32G04	21,64	2013-07-18	2023-11-10	Osisko Mining Inc.
2387706	32G04	4,06	2013-07-18	2023-11-10	Osisko Mining Inc.
2387707	32G04	36,59	2013-07-18	2023-11-10	Osisko Mining Inc.
2402808	32G04	56,44	2014-04-23	2023-04-22	Osisko Mining Inc.
2402809	32G04	56,44	2014-04-23	2023-04-22	Osisko Mining Inc.
2402810	32G04	56,44	2014-04-23	2023-04-22	Osisko Mining Inc.
2402811	32G04	56,38	2014-04-23	2023-04-22	Osisko Mining Inc.
2402812	32G04	56,38	2014-04-23	2023-04-22	Osisko Mining Inc.
2402813	32G04	56,38	2014-04-23	2023-04-22	Osisko Mining Inc.
2402814	32G04	56,37	2014-04-23	2023-04-22	Osisko Mining Inc.
2402815	32G04	56,37	2014-04-23	2023-04-22	Osisko Mining Inc.
2402816	32G04	56,37	2014-04-23	2023-04-22	Osisko Mining Inc.
2417076	32G03	56,46	2014-11-25	2023-11-24	Osisko Mining Inc.
2417077	32G03	56,46	2014-11-25	2023-11-24	Osisko Mining Inc.
2417078	32G03	56,46	2014-11-25	2023-11-24	Osisko Mining Inc.
2417079	32G03	56,45	2014-11-25	2023-11-24	Osisko Mining Inc.
2417080	32G03	56,45	2014-11-25	2023-11-24	Osisko Mining Inc.
2417081	32G03	56,45	2014-11-25	2023-11-24	Osisko Mining Inc.
2417082	32G03	56,45	2014-11-25	2023-11-24	Osisko Mining Inc.



Title	NTS	Area (ha)	Staking Date	Expiration Date	Owner (According to GESTIM)
2417083	32G03	56,44	2014-11-25	2023-11-24	Osisko Mining Inc.
2417084	32G03	56,44	2014-11-25	2023-11-24	Osisko Mining Inc.
2417085	32G03	56,44	2014-11-25	2023-11-24	Osisko Mining Inc.
2417086	32G03	56,44	2014-11-25	2023-11-24	Osisko Mining Inc.
2417088	32G03	56,43	2014-11-25	2023-11-24	Osisko Mining Inc.
2417089	32G03	56,43	2014-11-25	2023-11-24	Osisko Mining Inc.
2417090	32G03	56,43	2014-11-25	2023-11-24	Osisko Mining Inc.
2417091	32G03	56,43	2014-11-25	2023-11-24	Osisko Mining Inc.
2417092	32G03	56,43	2014-11-25	2023-11-24	Osisko Mining Inc.
2417093	32G03	56,43	2014-11-25	2023-11-24	Osisko Mining Inc.
2417094	32G03	56,42	2014-11-25	2023-11-24	Osisko Mining Inc.
2417095	32G03	56,42	2014-11-25	2023-11-24	Osisko Mining Inc.
2417096	32G03	56,42	2014-11-25	2023-11-24	Osisko Mining Inc.
2417097	32G03	56,42	2014-11-25	2023-11-24	Osisko Mining Inc.
2417098	32G03	56,42	2014-11-25	2023-11-24	Osisko Mining Inc.
2417099	32G03	56,42	2014-11-25	2023-11-24	Osisko Mining Inc.
2417100	32G03	56,42	2014-11-25	2023-11-24	Osisko Mining Inc.
2417101	32G03	56,42	2014-11-25	2023-11-24	Osisko Mining Inc.
2417102	32G03	56,41	2014-11-25	2023-11-24	Osisko Mining Inc.
2417103	32G03	56,41	2014-11-25	2023-11-24	Osisko Mining Inc.
2417104	32G03	56,41	2014-11-25	2023-11-24	Osisko Mining Inc.
2417105	32G03	56,41	2014-11-25	2023-11-24	Osisko Mining Inc.
2417106	32G03	56,41	2014-11-25	2023-11-24	Osisko Mining Inc.
2417107	32G03	56,41	2014-11-25	2023-11-24	Osisko Mining Inc.
2417108	32G03	56,41	2014-11-25	2023-11-24	Osisko Mining Inc.
2417109	32G03	56,41	2014-11-25	2023-11-24	Osisko Mining Inc.
2417110	32G03	56,41	2014-11-25	2023-11-24	Osisko Mining Inc.
2417111	32G03	56,41	2014-11-25	2023-11-24	Osisko Mining Inc.
2417112	32G03	56,40	2014-11-25	2023-11-24	Osisko Mining Inc.
2417113	32G03	56,40	2014-11-25	2023-11-24	Osisko Mining Inc.
2417114	32G03	56,40	2014-11-25	2023-11-24	Osisko Mining Inc.
2417115	32G03	56,40	2014-11-25	2023-11-24	Osisko Mining Inc.
2417116	32G03	56,43	2014-11-25	2023-11-24	Osisko Mining Inc.
2417117	32G03	56,43	2014-11-25	2023-11-24	Osisko Mining Inc.
2417118	32G03	56,42	2014-11-25	2023-11-24	Osisko Mining Inc.
2417119	32G03	56,41	2014-11-25	2023-11-24	Osisko Mining Inc.
2417120	32G03	56,40	2014-11-25	2023-11-24	Osisko Mining Inc.



Title	NTS	Area (ha)	Staking Date	Expiration Date	Owner (According to GESTIM)
2417121	32G03	56,40	2014-11-25	2023-11-24	Osisko Mining Inc.
2417122	32G03	56,40	2014-11-25	2023-11-24	Osisko Mining Inc.
2417123	32G03	56,40	2014-11-25	2023-11-24	Osisko Mining Inc.
2417124	32G03	56,40	2014-11-25	2023-11-24	Osisko Mining Inc.
2417125	32G03	56,40	2014-11-25	2023-11-24	Osisko Mining Inc.
2417126	32G03	56,40	2014-11-25	2023-11-24	Osisko Mining Inc.
2417127	32G03	56,40	2014-11-25	2023-11-24	Osisko Mining Inc.
2417128	32G03	56,40	2014-11-25	2023-11-24	Osisko Mining Inc.
2417129	32G03	56,40	2014-11-25	2023-11-24	Osisko Mining Inc.
2417130	32G03	56,40	2014-11-25	2023-11-24	Osisko Mining Inc.
2417131	32G03	56,40	2014-11-25	2023-11-24	Osisko Mining Inc.
2417132	32G03	56,40	2014-11-25	2023-11-24	Osisko Mining Inc.
2417133	32G03	56,40	2014-11-25	2023-11-24	Osisko Mining Inc.
2417134	32G03	56,40	2014-11-25	2023-11-24	Osisko Mining Inc.
2417135	32G03	56,39	2014-11-25	2023-11-24	Osisko Mining Inc.
2417136	32G03	56,39	2014-11-25	2023-11-24	Osisko Mining Inc.
2417137	32G03	56,39	2014-11-25	2023-11-24	Osisko Mining Inc.
2417138	32G03	56,39	2014-11-25	2023-11-24	Osisko Mining Inc.
2417139	32G03	56,39	2014-11-25	2023-11-24	Osisko Mining Inc.
2417140	32G03	56,39	2014-11-25	2023-11-24	Osisko Mining Inc.
2417141	32G03	56,39	2014-11-25	2023-11-24	Osisko Mining Inc.
2417142	32G03	56,39	2014-11-25	2023-11-24	Osisko Mining Inc.
2417143	32G03	56,39	2014-11-25	2023-11-24	Osisko Mining Inc.
2417144	32G03	56,39	2014-11-25	2023-11-24	Osisko Mining Inc.
2417145	32G03	56,39	2014-11-25	2023-11-24	Osisko Mining Inc.
2417146	32G03	56,39	2014-11-25	2023-11-24	Osisko Mining Inc.
2417147	32G03	56,39	2014-11-25	2023-11-24	Osisko Mining Inc.
2417220	32G03	56,38	2014-11-26	2023-11-25	Osisko Mining Inc.
2417221	32G03	56,37	2014-11-26	2023-11-25	Osisko Mining Inc.
2417222	32G03	56,36	2014-11-26	2023-11-25	Osisko Mining Inc.
2417223	32G03	56,35	2014-11-26	2023-11-25	Osisko Mining Inc.
2417224	32G03	56,35	2014-11-26	2023-11-25	Osisko Mining Inc.
2417225	32G03	56,35	2014-11-26	2023-11-25	Osisko Mining Inc.
2417226	32G03	56,35	2014-11-26	2023-11-25	Osisko Mining Inc.
2417227	32G03	56,35	2014-11-26	2023-11-25	Osisko Mining Inc.
2417228	32G03	56,35	2014-11-26	2023-11-25	Osisko Mining Inc.
2417229	32G03	56,35	2014-11-26	2023-11-25	Osisko Mining Inc.



Title	NTS	Area (ha)	Staking Date	Expiration Date	Owner (According to GESTIM)
2417230	32G03	56,35	2014-11-26	2023-11-25	Osisko Mining Inc.
2417231	32G03	56,35	2014-11-26	2023-11-25	Osisko Mining Inc.
2417232	32G03	56,35	2014-11-26	2023-11-25	Osisko Mining Inc.
2417233	32G03	56,35	2014-11-26	2023-11-25	Osisko Mining Inc.
2417234	32G03	56,35	2014-11-26	2023-11-25	Osisko Mining Inc.
2417235	32G03	56,35	2014-11-26	2023-11-25	Osisko Mining Inc.
2417236	32G03	56,35	2014-11-26	2023-11-25	Osisko Mining Inc.
2417238	32G03	56,34	2014-11-26	2023-11-25	Osisko Mining Inc.
2417239	32G03	56,34	2014-11-26	2023-11-25	Osisko Mining Inc.
2417240	32G03	56,34	2014-11-26	2023-11-25	Osisko Mining Inc.
2417241	32G03	56,34	2014-11-26	2023-11-25	Osisko Mining Inc.
2417242	32G03	56,34	2014-11-26	2023-11-25	Osisko Mining Inc.
2417243	32G03	56,34	2014-11-26	2023-11-25	Osisko Mining Inc.
2417244	32G03	56,34	2014-11-26	2023-11-25	Osisko Mining Inc.
2417245	32G03	56,34	2014-11-26	2023-11-25	Osisko Mining Inc.
2417246	32G03	56,34	2014-11-26	2023-11-25	Osisko Mining Inc.
2417247	32G03	56,34	2014-11-26	2023-11-25	Osisko Mining Inc.
2417248	32G03	56,34	2014-11-26	2023-11-25	Osisko Mining Inc.
2417249	32G03	56,34	2014-11-26	2023-11-25	Osisko Mining Inc.
2417250	32G03	56,34	2014-11-26	2023-11-25	Osisko Mining Inc.
2417251	32G03	56,33	2014-11-26	2023-11-25	Osisko Mining Inc.
2417252	32G03	56,33	2014-11-26	2023-11-25	Osisko Mining Inc.
2417253	32G03	56,33	2014-11-26	2023-11-25	Osisko Mining Inc.
2417254	32G03	56,33	2014-11-26	2023-11-25	Osisko Mining Inc.
2417255	32G03	56,33	2014-11-26	2023-11-25	Osisko Mining Inc.
2417256	32G03	56,33	2014-11-26	2023-11-25	Osisko Mining Inc.
2417257	32G03	56,33	2014-11-26	2023-11-25	Osisko Mining Inc.
2417258	32G03	56,33	2014-11-26	2023-11-25	Osisko Mining Inc.
2417259	32G03	56,33	2014-11-26	2023-11-25	Osisko Mining Inc.
2417260	32G03	56,33	2014-11-26	2023-11-25	Osisko Mining Inc.
2417261	32G03	56,33	2014-11-26	2023-11-25	Osisko Mining Inc.
2417266	32G04	56,38	2014-11-26	2023-11-25	Osisko Mining Inc.
2417267	32G04	56,37	2014-11-26	2023-11-25	Osisko Mining Inc.
2417382	32G03	56,40	2014-12-01	2023-11-30	Osisko Mining Inc.
2417383	32G03	56,40	2014-12-01	2023-11-30	Osisko Mining Inc.
2417384	32G03	56,40	2014-12-01	2023-11-30	Osisko Mining Inc.
2417385	32G03	56,39	2014-12-01	2023-11-30	Osisko Mining Inc.



Title	NTS	Area (ha)	Staking Date	Expiration Date	Owner (According to GESTIM)
2417386	32G03	56,39	2014-12-01	2023-11-30	Osisko Mining Inc.
2417387	32G03	56,39	2014-12-01	2023-11-30	Osisko Mining Inc.
2417388	32G03	56,39	2014-12-01	2023-11-30	Osisko Mining Inc.
2417389	32G03	56,39	2014-12-01	2023-11-30	Osisko Mining Inc.
2417390	32G03	56,39	2014-12-01	2023-11-30	Osisko Mining Inc.
2417391	32G03	56,39	2014-12-01	2023-11-30	Osisko Mining Inc.
2417392	32G03	56,39	2014-12-01	2023-11-30	Osisko Mining Inc.
2417393	32G03	56,39	2014-12-01	2023-11-30	Osisko Mining Inc.
2417394	32G03	56,39	2014-12-01	2023-11-30	Osisko Mining Inc.
2417395	32G03	56,38	2014-12-01	2023-11-30	Osisko Mining Inc.
2417396	32G03	56,38	2014-12-01	2023-11-30	Osisko Mining Inc.
2417397	32G03	56,38	2014-12-01	2023-11-30	Osisko Mining Inc.
2417398	32G03	56,38	2014-12-01	2023-11-30	Osisko Mining Inc.
2417399	32G03	56,38	2014-12-01	2023-11-30	Osisko Mining Inc.
2417400	32G03	56,38	2014-12-01	2023-11-30	Osisko Mining Inc.
2417401	32G03	56,38	2014-12-01	2023-11-30	Osisko Mining Inc.
2417402	32G03	56,37	2014-12-01	2023-11-30	Osisko Mining Inc.
2417403	32G03	56,37	2014-12-01	2023-11-30	Osisko Mining Inc.
2417404	32G03	56,37	2014-12-01	2023-11-30	Osisko Mining Inc.
2417405	32G03	56,37	2014-12-01	2023-11-30	Osisko Mining Inc.
2417406	32G03	56,36	2014-12-01	2023-11-30	Osisko Mining Inc.
2417407	32G03	56,36	2014-12-01	2023-11-30	Osisko Mining Inc.
2417408	32G03	56,36	2014-12-01	2023-11-30	Osisko Mining Inc.
2417409	32G03	56,36	2014-12-01	2023-11-30	Osisko Mining Inc.
2417410	32G03	56,36	2014-12-01	2023-11-30	Osisko Mining Inc.
2417411	32G03	56,36	2014-12-01	2023-11-30	Osisko Mining Inc.
2417412	32G03	56,35	2014-12-01	2023-11-30	Osisko Mining Inc.
2417416	32G03	56,34	2014-12-01	2023-11-30	Osisko Mining Inc.
2417417	32G03	56,34	2014-12-01	2023-11-30	Osisko Mining Inc.
2417418	32G03	56,34	2014-12-01	2023-11-30	Osisko Mining Inc.
2417419	32G03	56,40	2014-12-01	2023-11-30	Osisko Mining Inc.
2417420	32G03	56,39	2014-12-01	2023-11-30	Osisko Mining Inc.
2417421	32G03	56,39	2014-12-01	2023-11-30	Osisko Mining Inc.
2417422	32G03	56,39	2014-12-01	2023-11-30	Osisko Mining Inc.
2417423	32G03	56,39	2014-12-01	2023-11-30	Osisko Mining Inc.
2417424	32G03	56,38	2014-12-01	2023-11-30	Osisko Mining Inc.
2417425	32G03	56,38	2014-12-01	2023-11-30	Osisko Mining Inc.



Title	NTS	Area (ha)	Staking Date	Expiration Date	Owner (According to GESTIM)
2417426	32G03	56,38	2014-12-01	2023-11-30	Osisko Mining Inc.
2417427	32G03	56,38	2014-12-01	2023-11-30	Osisko Mining Inc.
2417428	32G03	56,38	2014-12-01	2023-11-30	Osisko Mining Inc.
2417429	32G03	56,38	2014-12-01	2023-11-30	Osisko Mining Inc.
2417430	32G03	56,38	2014-12-01	2023-11-30	Osisko Mining Inc.
2417431	32G03	56,38	2014-12-01	2023-11-30	Osisko Mining Inc.
2417432	32G03	56,38	2014-12-01	2023-11-30	Osisko Mining Inc.
2417433	32G03	56,37	2014-12-01	2023-11-30	Osisko Mining Inc.
2417434	32G03	56,37	2014-12-01	2023-11-30	Osisko Mining Inc.
2417435	32G03	56,37	2014-12-01	2023-11-30	Osisko Mining Inc.
2417436	32G03	56,37	2014-12-01	2023-11-30	Osisko Mining Inc.
2417437	32G03	56,37	2014-12-01	2023-11-30	Osisko Mining Inc.
2417438	32G03	56,37	2014-12-01	2023-11-30	Osisko Mining Inc.
2417439	32G03	56,37	2014-12-01	2023-11-30	Osisko Mining Inc.
2417440	32G03	56,37	2014-12-01	2023-11-30	Osisko Mining Inc.
2417441	32G03	56,37	2014-12-01	2023-11-30	Osisko Mining Inc.
2417442	32G03	56,37	2014-12-01	2023-11-30	Osisko Mining Inc.
2417443	32G03	56,36	2014-12-01	2023-11-30	Osisko Mining Inc.
2417444	32G03	56,36	2014-12-01	2023-11-30	Osisko Mining Inc.
2417445	32G03	56,36	2014-12-01	2023-11-30	Osisko Mining Inc.
2417446	32G03	56,36	2014-12-01	2023-11-30	Osisko Mining Inc.
2417447	32G03	56,36	2014-12-01	2023-11-30	Osisko Mining Inc.
2417448	32G03	56,36	2014-12-01	2023-11-30	Osisko Mining Inc.
2417449	32G03	56,36	2014-12-01	2023-11-30	Osisko Mining Inc.
2417450	32G03	56,36	2014-12-01	2023-11-30	Osisko Mining Inc.
2417451	32G03	56,35	2014-12-01	2023-11-30	Osisko Mining Inc.
2417452	32G03	56,35	2014-12-01	2023-11-30	Osisko Mining Inc.
2417453	32G03	56,35	2014-12-01	2023-11-30	Osisko Mining Inc.
2417454	32G03	56,35	2014-12-01	2023-11-30	Osisko Mining Inc.
2417457	32G03	56,34	2014-12-01	2023-11-30	Osisko Mining Inc.
2417458	32G03	56,34	2014-12-01	2023-11-30	Osisko Mining Inc.
2417537	32B13	56,60	2014-12-01	2023-11-30	Osisko Mining Inc.
2417538	32B13	56,60	2014-12-01	2023-11-30	Osisko Mining Inc.
2417539	32B13	56,60	2014-12-01	2023-11-30	Osisko Mining Inc.
2417540	32B13	56,60	2014-12-01	2023-11-30	Osisko Mining Inc.
2417541	32B13	56,60	2014-12-01	2023-11-30	Osisko Mining Inc.
2417542	32B13	56,60	2014-12-01	2023-11-30	Osisko Mining Inc.



Title	NTS	Area (ha)	Staking Date	Expiration Date	Owner (According to GESTIM)
2417543	32B13	56,59	2014-12-01	2023-11-30	Osisko Mining Inc.
2417544	32B13	56,59	2014-12-01	2023-11-30	Osisko Mining Inc.
2417545	32B13	56,59	2014-12-01	2023-11-30	Osisko Mining Inc.
2417546	32B13	56,59	2014-12-01	2023-11-30	Osisko Mining Inc.
2417547	32B13	56,59	2014-12-01	2023-11-30	Osisko Mining Inc.
2417548	32B13	56,59	2014-12-01	2023-11-30	Osisko Mining Inc.
2417549	32B13	56,59	2014-12-01	2023-11-30	Osisko Mining Inc.
2417550	32B13	56,59	2014-12-01	2023-11-30	Osisko Mining Inc.
2417551	32B13	56,58	2014-12-01	2023-11-30	Osisko Mining Inc.
2417552	32B13	56,58	2014-12-01	2023-11-30	Osisko Mining Inc.
2417553	32B13	56,58	2014-12-01	2023-11-30	Osisko Mining Inc.
2417554	32B13	56,58	2014-12-01	2023-11-30	Osisko Mining Inc.
2417555	32B13	56,56	2014-12-01	2023-11-30	Osisko Mining Inc.
2417556	32B13	56,56	2014-12-01	2023-11-30	Osisko Mining Inc.
2417557	32B13	56,56	2014-12-01	2023-11-30	Osisko Mining Inc.
2417558	32B13	56,56	2014-12-01	2023-11-30	Osisko Mining Inc.
2417559	32B13	56,56	2014-12-01	2023-11-30	Osisko Mining Inc.
2417560	32B13	56,56	2014-12-01	2023-11-30	Osisko Mining Inc.
2417561	32B13	56,56	2014-12-01	2023-11-30	Osisko Mining Inc.
2417562	32B13	56,56	2014-12-01	2023-11-30	Osisko Mining Inc.
2417563	32B13	56,55	2014-12-01	2023-11-30	Osisko Mining Inc.
2417564	32B13	56,55	2014-12-01	2023-11-30	Osisko Mining Inc.
2417565	32B13	56,55	2014-12-01	2023-11-30	Osisko Mining Inc.
2417566	32B13	56,55	2014-12-01	2023-11-30	Osisko Mining Inc.
2417567	32B13	56,55	2014-12-01	2023-11-30	Osisko Mining Inc.
2417568	32B13	56,55	2014-12-01	2023-11-30	Osisko Mining Inc.
2417569	32B13	56,55	2014-12-01	2023-11-30	Osisko Mining Inc.
2417570	32B13	56,55	2014-12-01	2023-11-30	Osisko Mining Inc.
2417571	32B13	56,54	2014-12-01	2023-11-30	Osisko Mining Inc.
2417572	32B13	56,54	2014-12-01	2023-11-30	Osisko Mining Inc.
2417573	32B13	56,54	2014-12-01	2023-11-30	Osisko Mining Inc.
2417574	32B13	56,54	2014-12-01	2023-11-30	Osisko Mining Inc.
2417575	32B13	56,54	2014-12-01	2023-11-30	Osisko Mining Inc.
2417576	32B13	56,54	2014-12-01	2023-11-30	Osisko Mining Inc.
2417577	32B13	56,54	2014-12-01	2023-11-30	Osisko Mining Inc.
2417578	32B13	56,54	2014-12-01	2023-11-30	Osisko Mining Inc.
2417579	32B13	56,50	2014-12-01	2023-11-30	Osisko Mining Inc.



Title	NTS	Area (ha)	Staking Date	Expiration Date	Owner (According to GESTIM)
2417581	32G03	56,46	2014-12-01	2023-11-30	Osisko Mining Inc.
2417582	32G03	56,46	2014-12-01	2023-11-30	Osisko Mining Inc.
2417583	32G03	56,46	2014-12-01	2023-11-30	Osisko Mining Inc.
2417584	32G03	56,46	2014-12-01	2023-11-30	Osisko Mining Inc.
2417585	32G03	56,46	2014-12-01	2023-11-30	Osisko Mining Inc.
2417586	32G03	56,45	2014-12-01	2023-11-30	Osisko Mining Inc.
2417587	32G03	56,45	2014-12-01	2023-11-30	Osisko Mining Inc.
2417588	32G03	56,45	2014-12-01	2023-11-30	Osisko Mining Inc.
2417589	32G03	56,45	2014-12-01	2023-11-30	Osisko Mining Inc.
2417590	32G03	56,45	2014-12-01	2023-11-30	Osisko Mining Inc.
2417593	32G03	56,44	2014-12-01	2023-11-30	Osisko Mining Inc.
2417594	32G03	56,44	2014-12-01	2023-11-30	Osisko Mining Inc.
2417595	32G03	56,44	2014-12-01	2023-11-30	Osisko Mining Inc.
2417596	32G03	56,44	2014-12-01	2023-11-30	Osisko Mining Inc.
2417597	32G03	56,43	2014-12-01	2023-11-30	Osisko Mining Inc.
2417598	32G03	56,43	2014-12-01	2023-11-30	Osisko Mining Inc.
2417599	32G03	56,43	2014-12-01	2023-11-30	Osisko Mining Inc.
2417600	32G03	56,42	2014-12-01	2023-11-30	Osisko Mining Inc.
2417601	32G03	56,42	2014-12-01	2023-11-30	Osisko Mining Inc.
2417602	32G03	56,42	2014-12-01	2023-11-30	Osisko Mining Inc.
2417603	32G03	56,37	2014-12-01	2023-11-30	Osisko Mining Inc.
2417604	32G03	56,37	2014-12-01	2023-11-30	Osisko Mining Inc.
2417605	32G03	56,37	2014-12-01	2023-11-30	Osisko Mining Inc.
2417606	32G03	56,37	2014-12-01	2023-11-30	Osisko Mining Inc.
2417607	32G03	56,37	2014-12-01	2023-11-30	Osisko Mining Inc.
2417608	32G03	56,36	2014-12-01	2023-11-30	Osisko Mining Inc.
2417609	32G03	56,36	2014-12-01	2023-11-30	Osisko Mining Inc.
2417610	32G03	56,36	2014-12-01	2023-11-30	Osisko Mining Inc.
2417611	32G03	56,36	2014-12-01	2023-11-30	Osisko Mining Inc.
2417612	32G03	56,36	2014-12-01	2023-11-30	Osisko Mining Inc.
2417613	32G03	56,35	2014-12-01	2023-11-30	Osisko Mining Inc.
2417614	32G03	56,35	2014-12-01	2023-11-30	Osisko Mining Inc.
2417615	32G03	56,35	2014-12-01	2023-11-30	Osisko Mining Inc.
2417618	32G04	56,36	2014-12-01	2023-11-30	Osisko Mining Inc.
2417619	32G04	56,36	2014-12-01	2023-11-30	Osisko Mining Inc.
2417620	32G04	56,36	2014-12-01	2023-11-30	Osisko Mining Inc.
2417621	32G04	56,36	2014-12-01	2023-11-30	Osisko Mining Inc.



Title	NTS	Area (ha)	Staking Date	Expiration Date	Owner (According to GESTIM)
2417622	32G04	56,35	2014-12-01	2023-11-30	Osisko Mining Inc.
2417623	32G04	56,35	2014-12-01	2023-11-30	Osisko Mining Inc.
2417624	32G04	56,35	2014-12-01	2023-11-30	Osisko Mining Inc.
2417625	32G04	56,35	2014-12-01	2023-11-30	Osisko Mining Inc.
2417626	32G04	56,35	2014-12-01	2023-11-30	Osisko Mining Inc.
2417627	32G04	56,34	2014-12-01	2023-11-30	Osisko Mining Inc.
2417628	32G04	56,34	2014-12-01	2023-11-30	Osisko Mining Inc.
2417629	32G04	56,34	2014-12-01	2023-11-30	Osisko Mining Inc.
2417630	32G04	56,34	2014-12-01	2023-11-30	Osisko Mining Inc.
2417631	32G04	56,34	2014-12-01	2023-11-30	Osisko Mining Inc.
2417655	32G03	56,40	2014-12-01	2023-11-30	Osisko Mining Inc.
2417656	32G03	56,40	2014-12-01	2023-11-30	Osisko Mining Inc.
2417657	32G03	56,40	2014-12-01	2023-11-30	Osisko Mining Inc.
2417658	32G03	56,40	2014-12-01	2023-11-30	Osisko Mining Inc.
2417659	32G03	56,40	2014-12-01	2023-11-30	Osisko Mining Inc.
2417660	32G03	56,40	2014-12-01	2023-11-30	Osisko Mining Inc.
2417661	32G03	56,39	2014-12-01	2023-11-30	Osisko Mining Inc.
2417662	32G03	56,39	2014-12-01	2023-11-30	Osisko Mining Inc.
2417663	32G03	56,39	2014-12-01	2023-11-30	Osisko Mining Inc.
2417664	32G03	56,39	2014-12-01	2023-11-30	Osisko Mining Inc.
2417665	32G03	56,39	2014-12-01	2023-11-30	Osisko Mining Inc.
2417666	32G03	56,39	2014-12-01	2023-11-30	Osisko Mining Inc.
2417667	32G03	56,39	2014-12-01	2023-11-30	Osisko Mining Inc.
2417668	32G03	56,39	2014-12-01	2023-11-30	Osisko Mining Inc.
2417669	32G03	56,39	2014-12-01	2023-11-30	Osisko Mining Inc.
2417670	32G03	56,39	2014-12-01	2023-11-30	Osisko Mining Inc.
2417671	32G03	56,39	2014-12-01	2023-11-30	Osisko Mining Inc.
2417672	32G03	56,39	2014-12-01	2023-11-30	Osisko Mining Inc.
2417673	32G03	56,38	2014-12-01	2023-11-30	Osisko Mining Inc.
2417674	32G03	56,38	2014-12-01	2023-11-30	Osisko Mining Inc.
2417675	32G03	56,38	2014-12-01	2023-11-30	Osisko Mining Inc.
2417676	32G03	56,38	2014-12-01	2023-11-30	Osisko Mining Inc.
2417677	32G03	56,38	2014-12-01	2023-11-30	Osisko Mining Inc.
2417678	32G03	56,37	2014-12-01	2023-11-30	Osisko Mining Inc.
2417679	32G03	56,37	2014-12-01	2023-11-30	Osisko Mining Inc.
2417680	32G03	56,37	2014-12-01	2023-11-30	Osisko Mining Inc.
2417681	32G03	56,37	2014-12-01	2023-11-30	Osisko Mining Inc.



Title	NTS	Area (ha)	Staking Date	Expiration Date	Owner (According to GESTIM)
2417682	32G03	56,37	2014-12-01	2023-11-30	Osisko Mining Inc.
2417683	32G03	56,37	2014-12-01	2023-11-30	Osisko Mining Inc.
2417684	32G03	56,36	2014-12-01	2023-11-30	Osisko Mining Inc.
2417685	32G03	56,36	2014-12-01	2023-11-30	Osisko Mining Inc.
2417686	32G03	56,36	2014-12-01	2023-11-30	Osisko Mining Inc.
2417687	32G03	56,36	2014-12-01	2023-11-30	Osisko Mining Inc.
2417688	32G03	56,36	2014-12-01	2023-11-30	Osisko Mining Inc.
2417689	32G03	56,35	2014-12-01	2023-11-30	Osisko Mining Inc.
2417690	32G03	56,35	2014-12-01	2023-11-30	Osisko Mining Inc.
2417691	32G03	56,35	2014-12-01	2023-11-30	Osisko Mining Inc.
2417692	32G03	56,35	2014-12-01	2023-11-30	Osisko Mining Inc.
2417693	32G03	56,35	2014-12-01	2023-11-30	Osisko Mining Inc.
2417694	32G03	56,34	2014-12-01	2023-11-30	Osisko Mining Inc.
2418096	32G03	56,40	2014-12-02	2023-12-01	Osisko Mining Inc.
2418097	32G03	56,40	2014-12-02	2023-12-01	Osisko Mining Inc.
2418098	32G03	56,40	2014-12-02	2023-12-01	Osisko Mining Inc.
2418099	32G03	56,40	2014-12-02	2023-12-01	Osisko Mining Inc.
2418100	32G03	56,40	2014-12-02	2023-12-01	Osisko Mining Inc.
2418101	32G03	56,40	2014-12-02	2023-12-01	Osisko Mining Inc.
2418102	32G03	56,40	2014-12-02	2023-12-01	Osisko Mining Inc.
2418103	32G03	56,39	2014-12-02	2023-12-01	Osisko Mining Inc.
2418104	32G03	56,39	2014-12-02	2023-12-01	Osisko Mining Inc.
2418105	32G03	56,39	2014-12-02	2023-12-01	Osisko Mining Inc.
2418106	32G03	56,39	2014-12-02	2023-12-01	Osisko Mining Inc.
2418107	32G03	56,39	2014-12-02	2023-12-01	Osisko Mining Inc.
2418108	32G03	56,39	2014-12-02	2023-12-01	Osisko Mining Inc.
2418109	32G03	56,39	2014-12-02	2023-12-01	Osisko Mining Inc.
2418110	32G03	56,39	2014-12-02	2023-12-01	Osisko Mining Inc.
2418111	32G03	56,39	2014-12-02	2023-12-01	Osisko Mining Inc.
2418112	32G03	56,39	2014-12-02	2023-12-01	Osisko Mining Inc.
2418113	32G03	56,39	2014-12-02	2023-12-01	Osisko Mining Inc.
2418114	32G03	56,39	2014-12-02	2023-12-01	Osisko Mining Inc.
2418115	32G03	56,39	2014-12-02	2023-12-01	Osisko Mining Inc.
2418116	32G03	56,39	2014-12-02	2023-12-01	Osisko Mining Inc.
2418117	32G03	56,38	2014-12-02	2023-12-01	Osisko Mining Inc.
2418118	32G03	56,38	2014-12-02	2023-12-01	Osisko Mining Inc.
2418119	32G03	56,38	2014-12-02	2023-12-01	Osisko Mining Inc.



Title	NTS	Area (ha)	Staking Date	Expiration Date	Owner (According to GESTIM)
2418120	32G03	56,38	2014-12-02	2023-12-01	Osisko Mining Inc.
2418121	32G03	56,38	2014-12-02	2023-12-01	Osisko Mining Inc.
2418122	32G03	56,38	2014-12-02	2023-12-01	Osisko Mining Inc.
2418123	32G03	56,38	2014-12-02	2023-12-01	Osisko Mining Inc.
2418124	32G03	56,38	2014-12-02	2023-12-01	Osisko Mining Inc.
2418125	32G03	56,37	2014-12-02	2023-12-01	Osisko Mining Inc.
2418126	32G03	56,37	2014-12-02	2023-12-01	Osisko Mining Inc.
2418127	32G03	56,37	2014-12-02	2023-12-01	Osisko Mining Inc.
2418128	32G03	56,37	2014-12-02	2023-12-01	Osisko Mining Inc.
2418129	32G03	56,37	2014-12-02	2023-12-01	Osisko Mining Inc.
2418130	32G03	56,37	2014-12-02	2023-12-01	Osisko Mining Inc.
2418131	32G03	56,36	2014-12-02	2023-12-01	Osisko Mining Inc.
2418133	32G03	56,45	2014-12-02	2023-12-01	Osisko Mining Inc.
2418134	32G03	56,43	2014-12-02	2023-12-01	Osisko Mining Inc.
2418135	32G03	56,41	2014-12-02	2023-12-01	Osisko Mining Inc.
2418136	32G03	56,40	2014-12-02	2023-12-01	Osisko Mining Inc.
2418137	32G03	56,40	2014-12-02	2023-12-01	Osisko Mining Inc.
2418138	32G03	56,38	2014-12-02	2023-12-01	Osisko Mining Inc.
2418139	32G03	56,38	2014-12-02	2023-12-01	Osisko Mining Inc.
2418140	32G03	56,38	2014-12-02	2023-12-01	Osisko Mining Inc.
2418141	32G03	56,37	2014-12-02	2023-12-01	Osisko Mining Inc.
2418142	32G03	56,37	2014-12-02	2023-12-01	Osisko Mining Inc.
2418143	32G03	56,37	2014-12-02	2023-12-01	Osisko Mining Inc.
2418144	32G03	56,37	2014-12-02	2023-12-01	Osisko Mining Inc.
2418145	32G03	56,36	2014-12-02	2023-12-01	Osisko Mining Inc.
2418146	32G03	56,36	2014-12-02	2023-12-01	Osisko Mining Inc.
2418147	32G03	56,36	2014-12-02	2023-12-01	Osisko Mining Inc.
2418148	32G03	56,36	2014-12-02	2023-12-01	Osisko Mining Inc.
2418149	32G03	56,36	2014-12-02	2023-12-01	Osisko Mining Inc.
2418150	32G03	56,36	2014-12-02	2023-12-01	Osisko Mining Inc.
2418151	32G03	56,36	2014-12-02	2023-12-01	Osisko Mining Inc.
2418152	32G03	56,36	2014-12-02	2023-12-01	Osisko Mining Inc.
2418153	32G03	56,36	2014-12-02	2023-12-01	Osisko Mining Inc.
2418154	32G03	56,36	2014-12-02	2023-12-01	Osisko Mining Inc.
2418155	32G03	56,36	2014-12-02	2023-12-01	Osisko Mining Inc.
2418156	32G03	56,35	2014-12-02	2023-12-01	Osisko Mining Inc.
2418157	32G03	56,35	2014-12-02	2023-12-01	Osisko Mining Inc.



Title	NTS	Area (ha)	Staking Date	Expiration Date	Owner (According to GESTIM)
2418158	32G03	56,35	2014-12-02	2023-12-01	Osisko Mining Inc.
2418159	32G03	56,35	2014-12-02	2023-12-01	Osisko Mining Inc.
2418160	32G03	56,35	2014-12-02	2023-12-01	Osisko Mining Inc.
2418161	32G03	56,35	2014-12-02	2023-12-01	Osisko Mining Inc.
2418162	32G03	56,35	2014-12-02	2023-12-01	Osisko Mining Inc.
2418163	32G03	56,35	2014-12-02	2023-12-01	Osisko Mining Inc.
2418164	32G03	56,35	2014-12-02	2023-12-01	Osisko Mining Inc.
2418165	32G03	56,35	2014-12-02	2023-12-01	Osisko Mining Inc.
2418166	32G03	56,35	2014-12-02	2023-12-01	Osisko Mining Inc.
2418167	32G03	56,35	2014-12-02	2023-12-01	Osisko Mining Inc.
2418168	32G03	56,35	2014-12-02	2023-12-01	Osisko Mining Inc.
2418169	32G03	56,35	2014-12-02	2023-12-01	Osisko Mining Inc.
2418170	32G03	56,35	2014-12-02	2023-12-01	Osisko Mining Inc.
2418370	32G03	56,41	2014-12-03	2023-12-02	Osisko Mining Inc.
2418371	32G03	56,40	2014-12-03	2023-12-02	Osisko Mining Inc.
2418372	32G03	56,40	2014-12-03	2023-12-02	Osisko Mining Inc.
2418373	32G03	56,40	2014-12-03	2023-12-02	Osisko Mining Inc.
2418374	32G03	56,40	2014-12-03	2023-12-02	Osisko Mining Inc.
2418375	32G03	56,38	2014-12-03	2023-12-02	Osisko Mining Inc.
2418376	32G03	56,37	2014-12-03	2023-12-02	Osisko Mining Inc.
2418377	32G03	56,37	2014-12-03	2023-12-02	Osisko Mining Inc.
2418378	32G03	56,34	2014-12-03	2023-12-02	Osisko Mining Inc.
2418379	32G03	56,34	2014-12-03	2023-12-02	Osisko Mining Inc.
2418380	32G03	56,34	2014-12-03	2023-12-02	Osisko Mining Inc.
2418381	32G03	56,34	2014-12-03	2023-12-02	Osisko Mining Inc.
2418382	32G03	56,34	2014-12-03	2023-12-02	Osisko Mining Inc.
2418383	32G03	56,34	2014-12-03	2023-12-02	Osisko Mining Inc.
2418384	32G03	56,34	2014-12-03	2023-12-02	Osisko Mining Inc.
2418385	32G03	56,34	2014-12-03	2023-12-02	Osisko Mining Inc.
2418386	32G03	56,33	2014-12-03	2023-12-02	Osisko Mining Inc.
2418387	32G03	56,33	2014-12-03	2023-12-02	Osisko Mining Inc.
2418388	32G03	56,33	2014-12-03	2023-12-02	Osisko Mining Inc.
2418389	32G03	56,33	2014-12-03	2023-12-02	Osisko Mining Inc.
2418390	32G03	56,33	2014-12-03	2023-12-02	Osisko Mining Inc.
2418391	32G03	56,32	2014-12-03	2023-12-02	Osisko Mining Inc.
2418392	32G03	56,32	2014-12-03	2023-12-02	Osisko Mining Inc.
2418393	32G03	56,32	2014-12-03	2023-12-02	Osisko Mining Inc.



Title	NTS	Area (ha)	Staking Date	Expiration Date	Owner (According to GESTIM)
2418394	32G03	56,32	2014-12-03	2023-12-02	Osisko Mining Inc.
2418395	32G03	56,32	2014-12-03	2023-12-02	Osisko Mining Inc.
2418396	32G03	56,32	2014-12-03	2023-12-02	Osisko Mining Inc.
2418397	32G03	56,32	2014-12-03	2023-12-02	Osisko Mining Inc.
2418398	32G03	56,32	2014-12-03	2023-12-02	Osisko Mining Inc.
2418399	32G03	56,32	2014-12-03	2023-12-02	Osisko Mining Inc.
2418400	32G03	56,32	2014-12-03	2023-12-02	Osisko Mining Inc.
2418401	32G03	56,31	2014-12-03	2023-12-02	Osisko Mining Inc.
2418402	32G03	56,31	2014-12-03	2023-12-02	Osisko Mining Inc.
2418403	32G03	56,31	2014-12-03	2023-12-02	Osisko Mining Inc.
2418404	32G03	56,31	2014-12-03	2023-12-02	Osisko Mining Inc.
2418405	32G03	56,31	2014-12-03	2023-12-02	Osisko Mining Inc.
2418406	32G03	56,31	2014-12-03	2023-12-02	Osisko Mining Inc.
2418407	32G03	56,31	2014-12-03	2023-12-02	Osisko Mining Inc.
2418408	32G03	56,31	2014-12-03	2023-12-02	Osisko Mining Inc.
2418409	32G03	56,31	2014-12-03	2023-12-02	Osisko Mining Inc.
2418433	32G03	56,43	2014-12-03	2023-12-02	Osisko Mining Inc.
2418434	32G03	56,42	2014-12-03	2023-12-02	Osisko Mining Inc.
2418435	32G03	56,42	2014-12-03	2023-12-02	Osisko Mining Inc.
2418436	32G03	56,39	2014-12-03	2023-12-02	Osisko Mining Inc.
2418437	32G03	56,39	2014-12-03	2023-12-02	Osisko Mining Inc.
2418438	32G03	56,39	2014-12-03	2023-12-02	Osisko Mining Inc.
2418439	32G03	56,35	2014-12-03	2023-12-02	Osisko Mining Inc.
2418440	32G03	56,35	2014-12-03	2023-12-02	Osisko Mining Inc.
2418441	32G03	56,35	2014-12-03	2023-12-02	Osisko Mining Inc.
2418442	32G03	56,35	2014-12-03	2023-12-02	Osisko Mining Inc.
2418444	32G03	56,34	2014-12-03	2023-12-02	Osisko Mining Inc.
2418445	32G03	56,34	2014-12-03	2023-12-02	Osisko Mining Inc.
2418450	32G03	56,42	2014-12-03	2023-12-02	Osisko Mining Inc.
2418451	32G03	56,41	2014-12-03	2023-12-02	Osisko Mining Inc.
2418452	32G03	56,41	2014-12-03	2023-12-02	Osisko Mining Inc.
2418453	32G03	56,38	2014-12-03	2023-12-02	Osisko Mining Inc.
2418454	32G03	56,38	2014-12-03	2023-12-02	Osisko Mining Inc.
2418455	32G03	56,37	2014-12-03	2023-12-02	Osisko Mining Inc.
2418456	32G03	56,37	2014-12-03	2023-12-02	Osisko Mining Inc.
2418457	32G03	56,37	2014-12-03	2023-12-02	Osisko Mining Inc.
2418458	32G03	56,36	2014-12-03	2023-12-02	Osisko Mining Inc.



Title	NTS	Area (ha)	Staking Date	Expiration Date	Owner (According to GESTIM)
2418459	32G03	56,36	2014-12-03	2023-12-02	Osisko Mining Inc.
2418460	32G03	56,36	2014-12-03	2023-12-02	Osisko Mining Inc.
2418461	32G03	56,35	2014-12-03	2023-12-02	Osisko Mining Inc.
2418462	32G03	56,35	2014-12-03	2023-12-02	Osisko Mining Inc.
2418463	32G03	56,35	2014-12-03	2023-12-02	Osisko Mining Inc.
2418464	32G03	56,35	2014-12-03	2023-12-02	Osisko Mining Inc.
2418465	32G03	56,35	2014-12-03	2023-12-02	Osisko Mining Inc.
2418466	32G03	56,35	2014-12-03	2023-12-02	Osisko Mining Inc.
2418467	32G03	56,34	2014-12-03	2023-12-02	Osisko Mining Inc.
2418472	32G03	56,34	2014-12-03	2023-12-02	Osisko Mining Inc.
2418473	32G03	56,34	2014-12-03	2023-12-02	Osisko Mining Inc.
2418474	32G03	56,34	2014-12-03	2023-12-02	Osisko Mining Inc.
2418475	32G03	56,34	2014-12-03	2023-12-02	Osisko Mining Inc.
2418476	32G03	56,34	2014-12-03	2023-12-02	Osisko Mining Inc.
2418477	32G03	56,34	2014-12-03	2023-12-02	Osisko Mining Inc.
2418484	32G03	56,33	2014-12-03	2023-12-02	Osisko Mining Inc.
2418485	32G03	56,33	2014-12-03	2023-12-02	Osisko Mining Inc.
2418486	32G03	56,33	2014-12-03	2023-12-02	Osisko Mining Inc.
2418487	32G03	56,33	2014-12-03	2023-12-02	Osisko Mining Inc.
2418488	32G03	56,33	2014-12-03	2023-12-02	Osisko Mining Inc.
2418544	32G03	56,45	2014-12-04	2023-12-03	Osisko Mining Inc.
2418545	32G03	56,44	2014-12-04	2023-12-03	Osisko Mining Inc.
2418546	32G03	56,44	2014-12-04	2023-12-03	Osisko Mining Inc.
2418547	32G03	56,44	2014-12-04	2023-12-03	Osisko Mining Inc.
2418548	32G03	56,44	2014-12-04	2023-12-03	Osisko Mining Inc.
2418549	32G03	56,44	2014-12-04	2023-12-03	Osisko Mining Inc.
2418550	32G03	56,42	2014-12-04	2023-12-03	Osisko Mining Inc.
2418551	32G03	56,42	2014-12-04	2023-12-03	Osisko Mining Inc.
2418552	32G03	56,42	2014-12-04	2023-12-03	Osisko Mining Inc.
2418553	32G03	56,42	2014-12-04	2023-12-03	Osisko Mining Inc.
2418554	32G03	56,41	2014-12-04	2023-12-03	Osisko Mining Inc.
2418555	32G03	56,40	2014-12-04	2023-12-03	Osisko Mining Inc.
2418556	32G03	56,40	2014-12-04	2023-12-03	Osisko Mining Inc.
2418557	32G03	56,40	2014-12-04	2023-12-03	Osisko Mining Inc.
2418558	32G03	56,40	2014-12-04	2023-12-03	Osisko Mining Inc.
2418559	32G03	56,40	2014-12-04	2023-12-03	Osisko Mining Inc.
2418560	32G03	56,40	2014-12-04	2023-12-03	Osisko Mining Inc.



Title	NTS	Area (ha)	Staking Date	Expiration Date	Owner (According to GESTIM)
2418561	32G03	56,39	2014-12-04	2023-12-03	Osisko Mining Inc.
2418562	32G03	56,39	2014-12-04	2023-12-03	Osisko Mining Inc.
2418563	32G03	56,38	2014-12-04	2023-12-03	Osisko Mining Inc.
2418564	32G03	56,37	2014-12-04	2023-12-03	Osisko Mining Inc.
2418565	32G03	56,36	2014-12-04	2023-12-03	Osisko Mining Inc.
2418574	32G03	56,33	2014-12-04	2023-12-03	Osisko Mining Inc.
2418575	32G03	56,33	2014-12-04	2023-12-03	Osisko Mining Inc.
2418576	32G03	56,33	2014-12-04	2023-12-03	Osisko Mining Inc.
2418577	32G03	56,33	2014-12-04	2023-12-03	Osisko Mining Inc.
2418618	32B13	56,62	2014-12-04	2023-12-03	Osisko Mining Inc.
2418619	32B13	56,62	2014-12-04	2023-12-03	Osisko Mining Inc.
2418620	32B13	56,62	2014-12-04	2023-12-03	Osisko Mining Inc.
2418621	32B13	56,62	2014-12-04	2023-12-03	Osisko Mining Inc.
2418622	32B13	56,62	2014-12-04	2023-12-03	Osisko Mining Inc.
2418623	32B13	56,62	2014-12-04	2023-12-03	Osisko Mining Inc.
2418624	32B13	56,61	2014-12-04	2023-12-03	Osisko Mining Inc.
2418625	32B13	56,61	2014-12-04	2023-12-03	Osisko Mining Inc.
2418626	32B13	56,61	2014-12-04	2023-12-03	Osisko Mining Inc.
2418627	32B13	56,61	2014-12-04	2023-12-03	Osisko Mining Inc.
2418628	32B13	56,61	2014-12-04	2023-12-03	Osisko Mining Inc.
2418629	32B13	56,61	2014-12-04	2023-12-03	Osisko Mining Inc.
2418630	32B13	56,61	2014-12-04	2023-12-03	Osisko Mining Inc.
2418631	32B13	56,61	2014-12-04	2023-12-03	Osisko Mining Inc.
2418632	32B13	56,61	2014-12-04	2023-12-03	Osisko Mining Inc.
2418633	32B13	56,61	2014-12-04	2023-12-03	Osisko Mining Inc.
2418634	32B13	56,61	2014-12-04	2023-12-03	Osisko Mining Inc.
2418635	32B13	56,61	2014-12-04	2023-12-03	Osisko Mining Inc.
2418636	32B13	56,61	2014-12-04	2023-12-03	Osisko Mining Inc.
2418637	32B13	56,61	2014-12-04	2023-12-03	Osisko Mining Inc.
2418638	32B13	56,61	2014-12-04	2023-12-03	Osisko Mining Inc.
2418639	32B13	56,61	2014-12-04	2023-12-03	Osisko Mining Inc.
2418640	32B13	56,60	2014-12-04	2023-12-03	Osisko Mining Inc.
2418641	32B13	56,60	2014-12-04	2023-12-03	Osisko Mining Inc.
2418642	32B13	56,60	2014-12-04	2023-12-03	Osisko Mining Inc.
2418643	32B13	56,60	2014-12-04	2023-12-03	Osisko Mining Inc.
2418644	32B13	56,60	2014-12-04	2023-12-03	Osisko Mining Inc.
2418645	32B13	56,59	2014-12-04	2023-12-03	Osisko Mining Inc.



Title	NTS	Area (ha)	Staking Date	Expiration Date	Owner (According to GESTIM)
2418646	32B13	56,58	2014-12-04	2023-12-03	Osisko Mining Inc.
2418647	32B13	56,58	2014-12-04	2023-12-03	Osisko Mining Inc.
2418648	32B13	56,58	2014-12-04	2023-12-03	Osisko Mining Inc.
2418649	32B13	56,57	2014-12-04	2023-12-03	Osisko Mining Inc.
2418650	32B13	56,57	2014-12-04	2023-12-03	Osisko Mining Inc.
2418651	32B13	56,57	2014-12-04	2023-12-03	Osisko Mining Inc.
2418652	32B13	56,57	2014-12-04	2023-12-03	Osisko Mining Inc.
2418653	32B13	56,57	2014-12-04	2023-12-03	Osisko Mining Inc.
2418654	32B13	56,57	2014-12-04	2023-12-03	Osisko Mining Inc.
2418655	32B13	56,56	2014-12-04	2023-12-03	Osisko Mining Inc.
2418656	32B13	56,56	2014-12-04	2023-12-03	Osisko Mining Inc.
2418657	32B13	56,56	2014-12-04	2023-12-03	Osisko Mining Inc.
2418658	32B13	56,56	2014-12-04	2023-12-03	Osisko Mining Inc.
2418659	32B13	56,56	2014-12-04	2023-12-03	Osisko Mining Inc.
2418660	32B13	56,55	2014-12-04	2023-12-03	Osisko Mining Inc.
2418661	32B13	56,55	2014-12-04	2023-12-03	Osisko Mining Inc.
2418662	32B13	56,55	2014-12-04	2023-12-03	Osisko Mining Inc.
2418663	32B13	56,55	2014-12-04	2023-12-03	Osisko Mining Inc.
2418664	32B13	56,53	2014-12-04	2023-12-03	Osisko Mining Inc.
2418665	32B13	56,53	2014-12-04	2023-12-03	Osisko Mining Inc.
2418666	32B13	56,53	2014-12-04	2023-12-03	Osisko Mining Inc.
2418667	32B13	56,53	2014-12-04	2023-12-03	Osisko Mining Inc.
2418679	32F01	56,40	2014-12-04	2023-12-03	Osisko Mining Inc.
2418680	32F01	56,39	2014-12-04	2023-12-03	Osisko Mining Inc.
2418681	32F01	56,39	2014-12-04	2023-12-03	Osisko Mining Inc.
2418682	32F01	56,39	2014-12-04	2023-12-03	Osisko Mining Inc.
2418683	32F01	56,39	2014-12-04	2023-12-03	Osisko Mining Inc.
2418684	32F01	56,38	2014-12-04	2023-12-03	Osisko Mining Inc.
2418685	32F01	56,38	2014-12-04	2023-12-03	Osisko Mining Inc.
2418686	32F01	56,38	2014-12-04	2023-12-03	Osisko Mining Inc.
2418687	32F01	56,38	2014-12-04	2023-12-03	Osisko Mining Inc.
2418688	32F01	56,38	2014-12-04	2023-12-03	Osisko Mining Inc.
2418689	32F01	56,37	2014-12-04	2023-12-03	Osisko Mining Inc.
2418690	32F01	56,37	2014-12-04	2023-12-03	Osisko Mining Inc.
2418691	32F01	56,37	2014-12-04	2023-12-03	Osisko Mining Inc.
2418692	32F01	56,37	2014-12-04	2023-12-03	Osisko Mining Inc.
2418693	32F01	56,37	2014-12-04	2023-12-03	Osisko Mining Inc.



Title	NTS	Area (ha)	Staking Date	Expiration Date	Owner (According to GESTIM)
2418694	32F01	56,37	2014-12-04	2023-12-03	Osisko Mining Inc.
2418695	32F01	56,37	2014-12-04	2023-12-03	Osisko Mining Inc.
2418696	32F01	56,37	2014-12-04	2023-12-03	Osisko Mining Inc.
2418697	32F01	56,36	2014-12-04	2023-12-03	Osisko Mining Inc.
2418698	32F01	56,36	2014-12-04	2023-12-03	Osisko Mining Inc.
2418699	32F01	56,36	2014-12-04	2023-12-03	Osisko Mining Inc.
2418700	32F01	56,36	2014-12-04	2023-12-03	Osisko Mining Inc.
2418702	32F01	56,36	2014-12-04	2023-12-03	Osisko Mining Inc.
2418703	32F01	56,36	2014-12-04	2023-12-03	Osisko Mining Inc.
2418704	32F01	56,36	2014-12-04	2023-12-03	Osisko Mining Inc.
2418705	32F01	56,36	2014-12-04	2023-12-03	Osisko Mining Inc.
2418706	32F01	56,36	2014-12-04	2023-12-03	Osisko Mining Inc.
2418708	32G03	56,41	2014-12-04	2023-12-03	Osisko Mining Inc.
2418709	32G03	56,41	2014-12-04	2023-12-03	Osisko Mining Inc.
2418710	32G03	56,40	2014-12-04	2023-12-03	Osisko Mining Inc.
2418711	32G03	56,38	2014-12-04	2023-12-03	Osisko Mining Inc.
2418712	32G03	56,36	2014-12-04	2023-12-03	Osisko Mining Inc.
2418713	32G03	56,36	2014-12-04	2023-12-03	Osisko Mining Inc.
2418714	32G03	56,34	2014-12-04	2023-12-03	Osisko Mining Inc.
2418719	32G03	56,33	2014-12-04	2023-12-03	Osisko Mining Inc.
2418748	32G03	56,38	2014-12-04	2023-12-03	Osisko Mining Inc.
2418749	32G03	56,34	2014-12-04	2023-12-03	Osisko Mining Inc.
2418750	32G03	56,34	2014-12-04	2023-12-03	Osisko Mining Inc.
2418751	32G03	56,34	2014-12-04	2023-12-03	Osisko Mining Inc.
2418752	32G03	56,34	2014-12-04	2023-12-03	Osisko Mining Inc.
2418753	32G03	56,34	2014-12-04	2023-12-03	Osisko Mining Inc.
2418754	32G03	56,34	2014-12-04	2023-12-03	Osisko Mining Inc.
2418755	32G03	56,34	2014-12-04	2023-12-03	Osisko Mining Inc.
2418787	32G04	56,44	2014-12-04	2023-12-03	Osisko Mining Inc.
2418789	32G04	56,45	2014-12-04	2023-12-03	Osisko Mining Inc.
2418790	32G04	56,45	2014-12-04	2023-12-03	Osisko Mining Inc.
2418791	32G04	56,45	2014-12-04	2023-12-03	Osisko Mining Inc.
2418792	32G04	56,44	2014-12-04	2023-12-03	Osisko Mining Inc.
2418793	32G04	56,44	2014-12-04	2023-12-03	Osisko Mining Inc.
2418794	32G04	56,44	2014-12-04	2023-12-03	Osisko Mining Inc.
2418796	32G04	56,43	2014-12-04	2023-12-03	Osisko Mining Inc.
2418797	32G04	56,43	2014-12-04	2023-12-03	Osisko Mining Inc.



Title	NTS	Area (ha)	Staking Date	Expiration Date	Owner (According to GESTIM)
2418799	32G04	56,39	2014-12-04	2023-12-03	Osisko Mining Inc.
2418800	32G04	56,39	2014-12-04	2023-12-03	Osisko Mining Inc.
2418801	32G04	56,39	2014-12-04	2023-12-03	Osisko Mining Inc.
2418802	32G04	56,39	2014-12-04	2023-12-03	Osisko Mining Inc.
2418803	32G04	56,39	2014-12-04	2023-12-03	Osisko Mining Inc.
2418804	32G04	56,39	2014-12-04	2023-12-03	Osisko Mining Inc.
2418805	32G04	56,39	2014-12-04	2023-12-03	Osisko Mining Inc.
2418806	32G04	56,39	2014-12-04	2023-12-03	Osisko Mining Inc.
2418807	32G04	56,39	2014-12-04	2023-12-03	Osisko Mining Inc.
2418808	32G04	56,38	2014-12-04	2023-12-03	Osisko Mining Inc.
2418809	32G04	56,38	2014-12-04	2023-12-03	Osisko Mining Inc.
2418810	32G04	56,38	2014-12-04	2023-12-03	Osisko Mining Inc.
2418811	32G04	56,38	2014-12-04	2023-12-03	Osisko Mining Inc.
2418812	32G04	56,38	2014-12-04	2023-12-03	Osisko Mining Inc.
2418813	32G04	56,38	2014-12-04	2023-12-03	Osisko Mining Inc.
2418814	32G04	56,38	2014-12-04	2023-12-03	Osisko Mining Inc.
2418815	32G04	56,38	2014-12-04	2023-12-03	Osisko Mining Inc.
2418816	32G04	56,38	2014-12-04	2023-12-03	Osisko Mining Inc.
2418817	32G04	56,38	2014-12-04	2023-12-03	Osisko Mining Inc.
2418818	32G04	56,38	2014-12-04	2023-12-03	Osisko Mining Inc.
2418819	32G04	56,38	2014-12-04	2023-12-03	Osisko Mining Inc.
2418820	32G04	56,37	2014-12-04	2023-12-03	Osisko Mining Inc.
2418821	32G04	56,37	2014-12-04	2023-12-03	Osisko Mining Inc.
2418822	32G04	56,37	2014-12-04	2023-12-03	Osisko Mining Inc.
2418823	32G04	56,37	2014-12-04	2023-12-03	Osisko Mining Inc.
2418824	32G04	56,37	2014-12-04	2023-12-03	Osisko Mining Inc.
2418825	32G04	56,37	2014-12-04	2023-12-03	Osisko Mining Inc.
2418826	32G04	56,37	2014-12-04	2023-12-03	Osisko Mining Inc.
2418827	32G04	56,37	2014-12-04	2023-12-03	Osisko Mining Inc.
2418828	32G04	56,37	2014-12-04	2023-12-03	Osisko Mining Inc.
2418829	32G04	56,37	2014-12-04	2023-12-03	Osisko Mining Inc.
2418830	32G04	56,37	2014-12-04	2023-12-03	Osisko Mining Inc.
2418831	32G04	56,37	2014-12-04	2023-12-03	Osisko Mining Inc.
2418832	32G04	56,37	2014-12-04	2023-12-03	Osisko Mining Inc.
2418833	32G04	56,37	2014-12-04	2023-12-03	Osisko Mining Inc.
2418834	32G04	56,37	2014-12-04	2023-12-03	Osisko Mining Inc.
2418835	32G04	56,37	2014-12-04	2023-12-03	Osisko Mining Inc.



Title	NTS	Area (ha)	Staking Date	Expiration Date	Owner (According to GESTIM)
2418836	32G04	56,37	2014-12-04	2023-12-03	Osisko Mining Inc.
2418837	32G04	56,36	2014-12-04	2023-12-03	Osisko Mining Inc.
2418838	32G04	56,36	2014-12-04	2023-12-03	Osisko Mining Inc.
2418839	32G04	56,36	2014-12-04	2023-12-03	Osisko Mining Inc.
2418840	32G04	56,36	2014-12-04	2023-12-03	Osisko Mining Inc.
2418841	32G04	56,36	2014-12-04	2023-12-03	Osisko Mining Inc.
2418842	32G04	56,36	2014-12-04	2023-12-03	Osisko Mining Inc.
2418843	32G04	56,36	2014-12-04	2023-12-03	Osisko Mining Inc.
2418844	32G04	56,36	2014-12-04	2023-12-03	Osisko Mining Inc.
2418845	32G04	56,36	2014-12-04	2023-12-03	Osisko Mining Inc.
2418846	32G04	56,36	2014-12-04	2023-12-03	Osisko Mining Inc.
2418847	32G04	56,36	2014-12-04	2023-12-03	Osisko Mining Inc.
2418848	32G04	56,36	2014-12-04	2023-12-03	Osisko Mining Inc.
2418849	32G04	56,35	2014-12-04	2023-12-03	Osisko Mining Inc.
2418850	32G04	56,35	2014-12-04	2023-12-03	Osisko Mining Inc.
2418863	32G04	56,36	2014-12-04	2023-12-03	Osisko Mining Inc.
2418864	32G04	56,36	2014-12-04	2023-12-03	Osisko Mining Inc.
2418865	32G04	56,35	2014-12-04	2023-12-03	Osisko Mining Inc.
2418866	32G04	56,35	2014-12-04	2023-12-03	Osisko Mining Inc.
2418867	32G04	56,35	2014-12-04	2023-12-03	Osisko Mining Inc.
2418868	32G04	56,35	2014-12-04	2023-12-03	Osisko Mining Inc.
2418869	32G04	56,35	2014-12-04	2023-12-03	Osisko Mining Inc.
2418870	32G04	56,35	2014-12-04	2023-12-03	Osisko Mining Inc.
2418871	32G04	56,35	2014-12-04	2023-12-03	Osisko Mining Inc.
2418872	32G04	56,35	2014-12-04	2023-12-03	Osisko Mining Inc.
2418873	32G04	56,35	2014-12-04	2023-12-03	Osisko Mining Inc.
2418874	32G04	56,35	2014-12-04	2023-12-03	Osisko Mining Inc.
2418875	32G04	56,35	2014-12-04	2023-12-03	Osisko Mining Inc.
2418876	32G04	56,35	2014-12-04	2023-12-03	Osisko Mining Inc.
2418877	32G04	56,35	2014-12-04	2023-12-03	Osisko Mining Inc.
2418878	32G04	56,35	2014-12-04	2023-12-03	Osisko Mining Inc.
2418879	32G04	56,35	2014-12-04	2023-12-03	Osisko Mining Inc.
2418880	32G04	56,35	2014-12-04	2023-12-03	Osisko Mining Inc.
2418881	32G04	56,34	2014-12-04	2023-12-03	Osisko Mining Inc.
2418882	32G04	56,34	2014-12-04	2023-12-03	Osisko Mining Inc.
2418883	32G04	56,34	2014-12-04	2023-12-03	Osisko Mining Inc.
2418884	32G04	56,34	2014-12-04	2023-12-03	Osisko Mining Inc.



Title	NTS	Area (ha)	Staking Date	Expiration Date	Owner (According to GESTIM)
2418885	32G04	56,34	2014-12-04	2023-12-03	Osisko Mining Inc.
2418886	32G04	56,34	2014-12-04	2023-12-03	Osisko Mining Inc.
2418887	32G04	56,34	2014-12-04	2023-12-03	Osisko Mining Inc.
2418888	32G04	56,34	2014-12-04	2023-12-03	Osisko Mining Inc.
2418889	32G04	56,34	2014-12-04	2023-12-03	Osisko Mining Inc.
2418890	32G04	56,34	2014-12-04	2023-12-03	Osisko Mining Inc.
2418891	32G04	56,34	2014-12-04	2023-12-03	Osisko Mining Inc.
2418892	32G04	56,34	2014-12-04	2023-12-03	Osisko Mining Inc.
2418893	32G04	56,34	2014-12-04	2023-12-03	Osisko Mining Inc.
2418894	32G04	56,34	2014-12-04	2023-12-03	Osisko Mining Inc.
2418895	32G04	56,34	2014-12-04	2023-12-03	Osisko Mining Inc.
2418896	32G04	56,34	2014-12-04	2023-12-03	Osisko Mining Inc.
2418897	32G04	56,34	2014-12-04	2023-12-03	Osisko Mining Inc.
2418898	32G04	56,33	2014-12-04	2023-12-03	Osisko Mining Inc.
2418899	32G04	56,33	2014-12-04	2023-12-03	Osisko Mining Inc.
2418900	32G04	56,33	2014-12-04	2023-12-03	Osisko Mining Inc.
2418912	32G03	56,44	2014-12-05	2023-12-04	Osisko Mining Inc.
2418913	32G03	56,44	2014-12-05	2023-12-04	Osisko Mining Inc.
2418914	32G03	56,44	2014-12-05	2023-12-04	Osisko Mining Inc.
2418915	32G03	56,43	2014-12-05	2023-12-04	Osisko Mining Inc.
2418916	32G03	56,43	2014-12-05	2023-12-04	Osisko Mining Inc.
2418917	32G03	56,43	2014-12-05	2023-12-04	Osisko Mining Inc.
2418918	32G03	56,43	2014-12-05	2023-12-04	Osisko Mining Inc.
2418919	32G03	56,43	2014-12-05	2023-12-04	Osisko Mining Inc.
2418920	32G03	56,43	2014-12-05	2023-12-04	Osisko Mining Inc.
2418921	32G03	56,43	2014-12-05	2023-12-04	Osisko Mining Inc.
2418922	32G03	56,43	2014-12-05	2023-12-04	Osisko Mining Inc.
2418923	32G03	56,42	2014-12-05	2023-12-04	Osisko Mining Inc.
2418924	32G03	56,42	2014-12-05	2023-12-04	Osisko Mining Inc.
2418925	32G03	56,42	2014-12-05	2023-12-04	Osisko Mining Inc.
2418926	32G03	56,42	2014-12-05	2023-12-04	Osisko Mining Inc.
2418927	32G03	56,42	2014-12-05	2023-12-04	Osisko Mining Inc.
2418928	32G03	56,42	2014-12-05	2023-12-04	Osisko Mining Inc.
2418929	32G03	56,42	2014-12-05	2023-12-04	Osisko Mining Inc.
2418930	32G03	56,42	2014-12-05	2023-12-04	Osisko Mining Inc.
2418931	32G03	56,42	2014-12-05	2023-12-04	Osisko Mining Inc.
2418932	32G03	56,42	2014-12-05	2023-12-04	Osisko Mining Inc.



Title	NTS	Area (ha)	Staking Date	Expiration Date	Owner (According to GESTIM)
2418933	32G03	56,41	2014-12-05	2023-12-04	Osisko Mining Inc.
2418934	32G03	56,41	2014-12-05	2023-12-04	Osisko Mining Inc.
2418935	32G03	56,41	2014-12-05	2023-12-04	Osisko Mining Inc.
2418936	32G03	56,41	2014-12-05	2023-12-04	Osisko Mining Inc.
2418937	32G03	56,41	2014-12-05	2023-12-04	Osisko Mining Inc.
2418938	32G03	56,41	2014-12-05	2023-12-04	Osisko Mining Inc.
2418939	32G03	56,41	2014-12-05	2023-12-04	Osisko Mining Inc.
2418940	32G03	56,41	2014-12-05	2023-12-04	Osisko Mining Inc.
2418941	32G03	56,40	2014-12-05	2023-12-04	Osisko Mining Inc.
2418942	32G03	56,40	2014-12-05	2023-12-04	Osisko Mining Inc.
2418943	32G03	56,40	2014-12-05	2023-12-04	Osisko Mining Inc.
2418944	32G03	56,40	2014-12-05	2023-12-04	Osisko Mining Inc.
2418945	32G03	56,40	2014-12-05	2023-12-04	Osisko Mining Inc.
2418946	32G03	56,40	2014-12-05	2023-12-04	Osisko Mining Inc.
2418947	32G03	56,40	2014-12-05	2023-12-04	Osisko Mining Inc.
2418948	32G03	56,40	2014-12-05	2023-12-04	Osisko Mining Inc.
2418949	32G03	56,39	2014-12-05	2023-12-04	Osisko Mining Inc.
2418950	32G03	56,39	2014-12-05	2023-12-04	Osisko Mining Inc.
2418951	32G03	56,39	2014-12-05	2023-12-04	Osisko Mining Inc.
2418953	32B13	56,61	2014-12-05	2023-12-04	Osisko Mining Inc.
2418956	32B13	56,60	2014-12-05	2023-12-04	Osisko Mining Inc.
2418957	32B13	56,60	2014-12-05	2023-12-04	Osisko Mining Inc.
2418958	32B13	56,60	2014-12-05	2023-12-04	Osisko Mining Inc.
2418959	32B13	56,60	2014-12-05	2023-12-04	Osisko Mining Inc.
2418963	32B13	56,59	2014-12-05	2023-12-04	Osisko Mining Inc.
2418964	32B13	56,59	2014-12-05	2023-12-04	Osisko Mining Inc.
2418965	32B13	56,59	2014-12-05	2023-12-04	Osisko Mining Inc.
2418966	32B13	56,59	2014-12-05	2023-12-04	Osisko Mining Inc.
2418972	32B13	56,58	2014-12-05	2023-12-04	Osisko Mining Inc.
2418973	32B13	56,58	2014-12-05	2023-12-04	Osisko Mining Inc.
2418974	32B13	56,58	2014-12-05	2023-12-04	Osisko Mining Inc.
2418991	32B13	56,56	2014-12-05	2023-12-04	Osisko Mining Inc.
2419029	32G03	56,39	2014-12-05	2023-12-04	Osisko Mining Inc.
2419031	32G03	56,35	2014-12-05	2023-12-04	Osisko Mining Inc.
2419111	32G04	56,40	2014-12-05	2023-12-04	Osisko Mining Inc.
2419112	32G04	56,40	2014-12-05	2023-12-04	Osisko Mining Inc.
2419113	32G04	56,39	2014-12-05	2023-12-04	Osisko Mining Inc.



Title	NTS	Area (ha)	Staking Date	Expiration Date	Owner (According to GESTIM)
2419114	32G04	56,39	2014-12-05	2023-12-04	Osisko Mining Inc.
2419115	32G04	56,39	2014-12-05	2023-12-04	Osisko Mining Inc.
2419116	32G04	56,39	2014-12-05	2023-12-04	Osisko Mining Inc.
2419117	32G04	56,39	2014-12-05	2023-12-04	Osisko Mining Inc.
2419118	32G04	56,39	2014-12-05	2023-12-04	Osisko Mining Inc.
2419119	32G04	56,38	2014-12-05	2023-12-04	Osisko Mining Inc.
2419120	32G04	56,38	2014-12-05	2023-12-04	Osisko Mining Inc.
2419121	32G04	56,38	2014-12-05	2023-12-04	Osisko Mining Inc.
2419122	32G04	56,38	2014-12-05	2023-12-04	Osisko Mining Inc.
2419123	32G04	56,38	2014-12-05	2023-12-04	Osisko Mining Inc.
2419124	32G04	56,38	2014-12-05	2023-12-04	Osisko Mining Inc.
2419125	32G04	56,38	2014-12-05	2023-12-04	Osisko Mining Inc.
2419126	32G04	56,38	2014-12-05	2023-12-04	Osisko Mining Inc.
2419127	32G04	56,37	2014-12-05	2023-12-04	Osisko Mining Inc.
2419128	32G04	56,37	2014-12-05	2023-12-04	Osisko Mining Inc.
2419129	32G04	56,37	2014-12-05	2023-12-04	Osisko Mining Inc.
2419130	32G04	56,37	2014-12-05	2023-12-04	Osisko Mining Inc.
2419131	32G04	56,37	2014-12-05	2023-12-04	Osisko Mining Inc.
2419132	32G04	56,36	2014-12-05	2023-12-04	Osisko Mining Inc.
2419133	32G04	56,36	2014-12-05	2023-12-04	Osisko Mining Inc.
2419134	32G04	56,36	2014-12-05	2023-12-04	Osisko Mining Inc.
2419135	32G04	56,36	2014-12-05	2023-12-04	Osisko Mining Inc.
2419136	32G04	56,36	2014-12-05	2023-12-04	Osisko Mining Inc.
2419137	32G04	56,36	2014-12-05	2023-12-04	Osisko Mining Inc.
2419138	32G04	56,36	2014-12-05	2023-12-04	Osisko Mining Inc.
2419139	32G04	56,36	2014-12-05	2023-12-04	Osisko Mining Inc.
2419140	32G04	56,36	2014-12-05	2023-12-04	Osisko Mining Inc.
2419141	32G04	56,35	2014-12-05	2023-12-04	Osisko Mining Inc.
2419142	32G04	56,35	2014-12-05	2023-12-04	Osisko Mining Inc.
2419143	32G04	56,35	2014-12-05	2023-12-04	Osisko Mining Inc.
2419144	32G04	56,35	2014-12-05	2023-12-04	Osisko Mining Inc.
2419145	32G04	56,35	2014-12-05	2023-12-04	Osisko Mining Inc.
2419146	32G04	56,35	2014-12-05	2023-12-04	Osisko Mining Inc.
2419147	32G04	56,35	2014-12-05	2023-12-04	Osisko Mining Inc.
2419148	32G04	56,35	2014-12-05	2023-12-04	Osisko Mining Inc.
2419149	32G04	56,35	2014-12-05	2023-12-04	Osisko Mining Inc.
2419157	32B13	56,61	2014-12-05	2023-12-04	Osisko Mining Inc.



Title	NTS	Area (ha)	Staking Date	Expiration Date	Owner (According to GESTIM)
2419158	32B13	56,60	2014-12-05	2023-12-04	Osisko Mining Inc.
2419159	32B13	56,60	2014-12-05	2023-12-04	Osisko Mining Inc.
2419160	32B13	56,59	2014-12-05	2023-12-04	Osisko Mining Inc.
2419161	32B13	56,57	2014-12-05	2023-12-04	Osisko Mining Inc.
2419169	32B13	56,52	2014-12-05	2023-12-04	Osisko Mining Inc.
2419170	32B13	56,51	2014-12-05	2023-12-04	Osisko Mining Inc.
2419580	32G04	56,45	2014-12-08	2023-12-07	Osisko Mining Inc.
2419581	32G04	56,45	2014-12-08	2023-12-07	Osisko Mining Inc.
2419873	32G04	56,36	2014-12-15	2023-12-14	Osisko Mining Inc.
2419874	32G04	56,40	2014-12-15	2023-12-14	Osisko Mining Inc.
2419875	32G04	56,40	2014-12-15	2023-12-14	Osisko Mining Inc.
2419876	32G04	56,39	2014-12-15	2023-12-14	Osisko Mining Inc.
2419877	32G04	56,39	2014-12-15	2023-12-14	Osisko Mining Inc.
2420621	32B13	56,63	2014-12-30	2023-12-29	Osisko Mining Inc.
2420622	32B13	56,62	2014-12-30	2023-12-29	Osisko Mining Inc.
2420623	32B13	56,62	2014-12-30	2023-12-29	Osisko Mining Inc.
2420624	32B13	56,62	2014-12-30	2023-12-29	Osisko Mining Inc.
2420625	32B13	56,62	2014-12-30	2023-12-29	Osisko Mining Inc.
2420626	32B13	56,62	2014-12-30	2023-12-29	Osisko Mining Inc.
2420627	32B13	56,62	2014-12-30	2023-12-29	Osisko Mining Inc.
2420628	32B13	56,62	2014-12-30	2023-12-29	Osisko Mining Inc.
2420629	32B13	56,62	2014-12-30	2023-12-29	Osisko Mining Inc.
2420630	32B13	56,62	2014-12-30	2023-12-29	Osisko Mining Inc.
2420631	32B13	56,62	2014-12-30	2023-12-29	Osisko Mining Inc.
2420632	32B13	56,62	2014-12-30	2023-12-29	Osisko Mining Inc.
2420633	32B13	56,56	2014-12-30	2023-12-29	Osisko Mining Inc.
2420634	32B13	56,56	2014-12-30	2023-12-29	Osisko Mining Inc.
2420636	32B13	56,55	2014-12-30	2023-12-29	Osisko Mining Inc.
2420637	32B13	56,55	2014-12-30	2023-12-29	Osisko Mining Inc.
2420639	32B13	56,54	2014-12-30	2023-12-29	Osisko Mining Inc.
2420640	32B13	56,54	2014-12-30	2023-12-29	Osisko Mining Inc.
2420641	32B13	56,53	2014-12-30	2023-12-29	Osisko Mining Inc.
2420642	32B13	56,53	2014-12-30	2023-12-29	Osisko Mining Inc.
2420643	32B13	56,53	2014-12-30	2023-12-29	Osisko Mining Inc.
2420646	32B13	56,52	2014-12-30	2023-12-29	Osisko Mining Inc.
2420647	32B13	56,52	2014-12-30	2023-12-29	Osisko Mining Inc.
2420648	32B13	56,52	2014-12-30	2023-12-29	Osisko Mining Inc.



Title	NTS	Area (ha)	Staking Date	Expiration Date	Owner (According to GESTIM)
2420649	32B13	56,52	2014-12-30	2023-12-29	Osisko Mining Inc.
2420650	32B13	56,52	2014-12-30	2023-12-29	Osisko Mining Inc.
2420653	32B13	56,51	2014-12-30	2023-12-29	Osisko Mining Inc.
2420654	32B13	56,51	2014-12-30	2023-12-29	Osisko Mining Inc.
2420655	32B13	56,51	2014-12-30	2023-12-29	Osisko Mining Inc.
2420656	32B13	56,51	2014-12-30	2023-12-29	Osisko Mining Inc.
2420663	32F01	56,38	2014-12-30	2023-12-29	Osisko Mining Inc.
2420665	32G03	56,32	2014-12-30	2023-12-29	Osisko Mining Inc.
2420673	32G04	56,41	2014-12-30	2023-12-29	Osisko Mining Inc.
2420674	32G04	56,34	2014-12-30	2023-12-29	Osisko Mining Inc.
2420675	32G04	56,34	2014-12-30	2023-12-29	Osisko Mining Inc.
2420676	32G04	56,34	2014-12-30	2023-12-29	Osisko Mining Inc.
2420677	32G04	56,33	2014-12-30	2023-12-29	Osisko Mining Inc.
2420678	32G04	56,33	2014-12-30	2023-12-29	Osisko Mining Inc.
2420679	32G04	56,33	2014-12-30	2023-12-29	Osisko Mining Inc.
2420680	32G04	56,33	2014-12-30	2023-12-29	Osisko Mining Inc.
2420834	32G03	55,97	2014-12-30	2023-12-29	Osisko Mining Inc.
2424083	32G04	56,43	2015-03-05	2024-03-04	Osisko Mining Inc.
2424084	32G04	56,43	2015-03-05	2024-03-04	Osisko Mining Inc.
2424085	32G04	56,43	2015-03-05	2024-03-04	Osisko Mining Inc.
2424086	32G04	56,43	2015-03-05	2024-03-04	Osisko Mining Inc.
2424087	32G04	56,42	2015-03-05	2024-03-04	Osisko Mining Inc.
2424088	32G04	56,42	2015-03-05	2024-03-04	Osisko Mining Inc.
2424089	32G04	56,41	2015-03-05	2024-03-04	Osisko Mining Inc.
2424090	32G04	56,41	2015-03-05	2024-03-04	Osisko Mining Inc.
2424091	32G04	56,41	2015-03-05	2024-03-04	Osisko Mining Inc.
2424092	32G04	56,40	2015-03-05	2024-03-04	Osisko Mining Inc.
2424093	32G04	56,40	2015-03-05	2024-03-04	Osisko Mining Inc.
2424094	32G04	56,40	2015-03-05	2024-03-04	Osisko Mining Inc.
2424095	32G04	56,40	2015-03-05	2024-03-04	Osisko Mining Inc.
2424096	32G04	56,39	2015-03-05	2024-03-04	Osisko Mining Inc.
2426099	32B13	56,57	2015-04-10	2024-04-09	Osisko Mining Inc.
2426100	32B13	56,57	2015-04-10	2024-04-09	Osisko Mining Inc.
2426101	32B13	56,56	2015-04-10	2024-04-09	Osisko Mining Inc.
2426102	32B13	56,56	2015-04-10	2024-04-09	Osisko Mining Inc.
2426103	32B13	56,55	2015-04-10	2024-04-09	Osisko Mining Inc.
2427494	32G04	56,36	2015-05-11	2024-05-10	Osisko Mining Inc.



Title	NTS	Area (ha)	Staking Date	Expiration Date	Owner (According to GESTIM)
2427495	32G04	56,36	2015-05-11	2024-05-10	Osisko Mining Inc.
2427776	32G04	56,35	2015-05-19	2024-05-18	Osisko Mining Inc.
2428339	32G04	56,37	2015-06-02	2024-06-01	Osisko Mining Inc.
2428340	32G04	56,37	2015-06-02	2024-06-01	Osisko Mining Inc.
2428341	32G04	56,36	2015-06-02	2024-06-01	Osisko Mining Inc.
2428342	32G04	56,43	2015-06-02	2024-06-01	Osisko Mining Inc.
2429947	32B13	56,53	2015-07-08	2024-07-07	Osisko Mining Inc.
2429948	32B13	56,52	2015-07-08	2024-07-07	Osisko Mining Inc.
2429949	32B13	56,51	2015-07-08	2024-07-07	Osisko Mining Inc.
2431719	32G04	56,36	2015-07-30	2024-07-29	Osisko Mining Inc.
2432474	32G03	56,38	2015-08-21	2024-08-20	Osisko Mining Inc.
2432475	32G03	56,38	2015-08-21	2024-08-20	Osisko Mining Inc.
2440725	32G03	56,38	2016-04-12	2023-04-11	Osisko Mining Inc.
2443381	32G03	56,32	2016-04-26	2023-04-25	Osisko Mining Inc.
2443382	32G03	56,32	2016-04-26	2023-04-25	Osisko Mining Inc.
2443383	32G03	56,32	2016-04-26	2023-04-25	Osisko Mining Inc.
2443384	32G03	56,32	2016-04-26	2023-04-25	Osisko Mining Inc.
2443385	32G03	56,32	2016-04-26	2023-04-25	Osisko Mining Inc.
2443386	32G03	56,31	2016-04-26	2023-04-25	Osisko Mining Inc.
2443387	32G03	56,31	2016-04-26	2023-04-25	Osisko Mining Inc.
2443388	32G03	56,31	2016-04-26	2023-04-25	Osisko Mining Inc.
2443389	32G03	56,31	2016-04-26	2023-04-25	Osisko Mining Inc.
2443390	32G03	56,31	2016-04-26	2023-04-25	Osisko Mining Inc.
2443391	32G03	56,30	2016-04-26	2023-04-25	Osisko Mining Inc.
2443392	32G03	56,30	2016-04-26	2023-04-25	Osisko Mining Inc.
2443393	32G03	56,30	2016-04-26	2023-04-25	Osisko Mining Inc.
2443394	32G03	56,30	2016-04-26	2023-04-25	Osisko Mining Inc.
2443396	32G03	56,29	2016-04-26	2023-04-25	Osisko Mining Inc.
2443397	32G03	56,29	2016-04-26	2023-04-25	Osisko Mining Inc.
2443398	32G03	56,29	2016-04-26	2023-04-25	Osisko Mining Inc.
2443399	32G03	56,29	2016-04-26	2023-04-25	Osisko Mining Inc.
2443400	32G03	56,29	2016-04-26	2023-04-25	Osisko Mining Inc.
2443401	32G03	56,29	2016-04-26	2023-04-25	Osisko Mining Inc.
2443402	32G03	56,29	2016-04-26	2023-04-25	Osisko Mining Inc.
2443403	32G03	56,29	2016-04-26	2023-04-25	Osisko Mining Inc.
2443404	32G03	56,29	2016-04-26	2023-04-25	Osisko Mining Inc.
2443405	32G03	56,29	2016-04-26	2023-04-25	Osisko Mining Inc.



Title	NTS	Area (ha)	Staking Date	Expiration Date	Owner (According to GESTIM)
2443406	32G03	56,29	2016-04-26	2023-04-25	Osisko Mining Inc.
2443410	32G03	56,28	2016-04-26	2023-04-25	Osisko Mining Inc.
2443411	32G03	56,28	2016-04-26	2023-04-25	Osisko Mining Inc.
2443412	32G03	56,28	2016-04-26	2023-04-25	Osisko Mining Inc.
2443413	32G03	56,28	2016-04-26	2023-04-25	Osisko Mining Inc.
2443414	32G03	56,28	2016-04-26	2023-04-25	Osisko Mining Inc.
2443421	32G03	56,32	2016-04-26	2023-04-25	Osisko Mining Inc.
2443422	32G03	56,32	2016-04-26	2023-04-25	Osisko Mining Inc.
2443423	32G03	56,32	2016-04-26	2023-04-25	Osisko Mining Inc.
2443424	32G03	56,32	2016-04-26	2023-04-25	Osisko Mining Inc.
2443425	32G03	56,32	2016-04-26	2023-04-25	Osisko Mining Inc.
2443426	32G03	56,32	2016-04-26	2023-04-25	Osisko Mining Inc.
2443427	32G03	56,32	2016-04-26	2023-04-25	Osisko Mining Inc.
2443428	32G03	56,31	2016-04-26	2023-04-25	Osisko Mining Inc.
2443429	32G03	56,31	2016-04-26	2023-04-25	Osisko Mining Inc.
2443430	32G03	56,30	2016-04-26	2023-04-25	Osisko Mining Inc.
2443431	32G03	56,30	2016-04-26	2023-04-25	Osisko Mining Inc.
2443432	32G03	56,30	2016-04-26	2023-04-25	Osisko Mining Inc.
2443433	32G03	56,30	2016-04-26	2023-04-25	Osisko Mining Inc.
2443434	32G03	56,30	2016-04-26	2023-04-25	Osisko Mining Inc.
2443440	32G03	56,29	2016-04-26	2023-04-25	Osisko Mining Inc.
2443441	32G03	56,29	2016-04-26	2023-04-25	Osisko Mining Inc.
2444079	32G02	56,31	2016-05-05	2023-05-04	Osisko Mining Inc.
2444080	32G02	56,31	2016-05-05	2023-05-04	Osisko Mining Inc.
2450641	32G03	43,81	2016-06-22	2023-06-21	Osisko Mining Inc.
2450962	32G03	7,80	2016-06-23	2023-06-22	Osisko Mining Inc.
2450964	32G03	47,50	2016-06-23	2023-06-22	Osisko Mining Inc.
2450965	32G03	24,03	2016-06-23	2023-06-22	Osisko Mining Inc.
2450966	32G03	2,27	2016-06-23	2023-06-22	Osisko Mining Inc.
2450967	32G03	0,50	2016-06-23	2023-06-22	Osisko Mining Inc.
2450968	32G03	0,11	2016-06-23	2023-06-22	Osisko Mining Inc.
2450969	32G03	13,30	2016-06-23	2023-06-22	Osisko Mining Inc.
2450970	32G03	7,59	2016-06-23	2023-06-22	Osisko Mining Inc.
2454299	32G03	0,04	2016-07-22	2023-07-21	Osisko Mining Inc.
2454300	32G03	2,62	2016-07-22	2023-07-21	Osisko Mining Inc.
2454301	32G03	54,46	2016-07-22	2023-07-21	Osisko Mining Inc.
2457875	32G03	56,41	2016-08-17	2023-08-16	Osisko Mining Inc.



Title	NTS	Area (ha)	Staking Date	Expiration Date	Owner (According to GESTIM)
2458310	32G03	56,41	2016-08-17	2023-08-16	Osisko Mining Inc.
2458311	32G03	56,41	2016-08-17	2023-08-16	Osisko Mining Inc.
2459947	32F01	56,38	2016-08-31	2023-08-30	Osisko Mining Inc.
2459948	32F01	56,38	2016-08-31	2023-08-30	Osisko Mining Inc.
2459949	32F01	56,38	2016-08-31	2023-08-30	Osisko Mining Inc.
2459950	32F01	56,38	2016-08-31	2023-08-30	Osisko Mining Inc.
2459951	32F01	56,38	2016-08-31	2023-08-30	Osisko Mining Inc.
2459952	32F01	56,38	2016-08-31	2023-08-30	Osisko Mining Inc.
2459953	32F01	56,38	2016-08-31	2023-08-30	Osisko Mining Inc.
2459954	32F01	56,38	2016-08-31	2023-08-30	Osisko Mining Inc.
2459955	32F01	56,38	2016-08-31	2023-08-30	Osisko Mining Inc.
2459956	32F01	56,38	2016-08-31	2023-08-30	Osisko Mining Inc.
2459957	32F01	56,38	2016-08-31	2023-08-30	Osisko Mining Inc.
2459958	32F01	56,38	2016-08-31	2023-08-30	Osisko Mining Inc.
2459959	32F01	56,38	2016-08-31	2023-08-30	Osisko Mining Inc.
2459960	32F01	56,38	2016-08-31	2023-08-30	Osisko Mining Inc.
2459961	32F01	56,38	2016-08-31	2023-08-30	Osisko Mining Inc.
2459962	32F01	56,37	2016-08-31	2023-08-30	Osisko Mining Inc.
2459963	32F01	56,37	2016-08-31	2023-08-30	Osisko Mining Inc.
2459964	32F01	56,37	2016-08-31	2023-08-30	Osisko Mining Inc.
2459965	32F01	56,37	2016-08-31	2023-08-30	Osisko Mining Inc.
2459966	32F01	56,37	2016-08-31	2023-08-30	Osisko Mining Inc.
2459967	32F01	56,37	2016-08-31	2023-08-30	Osisko Mining Inc.
2459968	32F01	56,37	2016-08-31	2023-08-30	Osisko Mining Inc.
2459969	32F01	56,37	2016-08-31	2023-08-30	Osisko Mining Inc.
2459970	32F01	56,37	2016-08-31	2023-08-30	Osisko Mining Inc.
2459971	32F01	56,37	2016-08-31	2023-08-30	Osisko Mining Inc.
2459972	32F01	56,37	2016-08-31	2023-08-30	Osisko Mining Inc.
2459973	32F01	56,37	2016-08-31	2023-08-30	Osisko Mining Inc.
2459974	32F01	56,37	2016-08-31	2023-08-30	Osisko Mining Inc.
2459975	32F01	56,37	2016-08-31	2023-08-30	Osisko Mining Inc.
2459976	32F01	56,37	2016-08-31	2023-08-30	Osisko Mining Inc.
2459977	32F01	56,37	2016-08-31	2023-08-30	Osisko Mining Inc.
2459978	32F01	56,37	2016-08-31	2023-08-30	Osisko Mining Inc.
2459979	32F01	56,37	2016-08-31	2023-08-30	Osisko Mining Inc.
2459980	32F01	56,37	2016-08-31	2023-08-30	Osisko Mining Inc.
2459981	32F01	56,37	2016-08-31	2023-08-30	Osisko Mining Inc.



Title	NTS	Area (ha)	Staking Date	Expiration Date	Owner (According to GESTIM)
2459982	32F01	56,37	2016-08-31	2023-08-30	Osisko Mining Inc.
2459983	32F01	56,37	2016-08-31	2023-08-30	Osisko Mining Inc.
2459984	32F01	56,37	2016-08-31	2023-08-30	Osisko Mining Inc.
2459985	32F01	56,37	2016-08-31	2023-08-30	Osisko Mining Inc.
2459986	32F01	56,37	2016-08-31	2023-08-30	Osisko Mining Inc.
2459987	32F01	56,37	2016-08-31	2023-08-30	Osisko Mining Inc.
2459988	32F01	56,36	2016-08-31	2023-08-30	Osisko Mining Inc.
2459989	32F01	56,36	2016-08-31	2023-08-30	Osisko Mining Inc.
2459990	32F01	56,36	2016-08-31	2023-08-30	Osisko Mining Inc.
2459991	32F01	56,36	2016-08-31	2023-08-30	Osisko Mining Inc.
2459992	32F01	56,36	2016-08-31	2023-08-30	Osisko Mining Inc.
2459993	32F01	56,36	2016-08-31	2023-08-30	Osisko Mining Inc.
2459994	32F01	56,36	2016-08-31	2023-08-30	Osisko Mining Inc.
2459995	32F01	56,36	2016-08-31	2023-08-30	Osisko Mining Inc.
2459996	32F01	56,36	2016-08-31	2023-08-30	Osisko Mining Inc.
2459997	32F01	56,36	2016-08-31	2023-08-30	Osisko Mining Inc.
2459998	32F01	56,36	2016-08-31	2023-08-30	Osisko Mining Inc.
2459999	32F01	56,36	2016-08-31	2023-08-30	Osisko Mining Inc.
2460000	32F01	56,36	2016-08-31	2023-08-30	Osisko Mining Inc.
2460001	32F01	56,36	2016-08-31	2023-08-30	Osisko Mining Inc.
2460002	32F01	56,36	2016-08-31	2023-08-30	Osisko Mining Inc.
2460003	32F01	56,36	2016-08-31	2023-08-30	Osisko Mining Inc.
2460004	32F01	56,36	2016-08-31	2023-08-30	Osisko Mining Inc.
2460005	32F01	56,36	2016-08-31	2023-08-30	Osisko Mining Inc.
2460006	32F01	56,36	2016-08-31	2023-08-30	Osisko Mining Inc.
2460007	32F01	56,36	2016-08-31	2023-08-30	Osisko Mining Inc.
2460008	32F01	56,35	2016-08-31	2023-08-30	Osisko Mining Inc.
2460009	32F01	56,35	2016-08-31	2023-08-30	Osisko Mining Inc.
2460010	32F01	56,35	2016-08-31	2023-08-30	Osisko Mining Inc.
2460011	32F01	56,35	2016-08-31	2023-08-30	Osisko Mining Inc.
2460012	32F01	56,35	2016-08-31	2023-08-30	Osisko Mining Inc.
2460013	32F01	56,35	2016-08-31	2023-08-30	Osisko Mining Inc.
2460014	32F01	56,35	2016-08-31	2023-08-30	Osisko Mining Inc.
2460015	32F01	56,35	2016-08-31	2023-08-30	Osisko Mining Inc.
2460019	32F01	56,35	2016-08-31	2023-08-30	Osisko Mining Inc.
2460020	32F01	56,35	2016-08-31	2023-08-30	Osisko Mining Inc.
2460021	32F01	56,35	2016-08-31	2023-08-30	Osisko Mining Inc.



Title	NTS	Area (ha)	Staking Date	Expiration Date	Owner (According to GESTIM)
2460022	32F01	56,35	2016-08-31	2023-08-30	Osisko Mining Inc.
2460023	32F01	56,35	2016-08-31	2023-08-30	Osisko Mining Inc.
2460024	32F01	56,35	2016-08-31	2023-08-30	Osisko Mining Inc.
2460025	32F01	56,35	2016-08-31	2023-08-30	Osisko Mining Inc.
2460026	32F01	56,35	2016-08-31	2023-08-30	Osisko Mining Inc.
2460305	32F01	56,37	2016-08-31	2023-08-30	Osisko Mining Inc.
2460306	32F01	56,36	2016-08-31	2023-08-30	Osisko Mining Inc.
2460307	32F01	56,36	2016-08-31	2023-08-30	Osisko Mining Inc.
2460308	32F01	56,36	2016-08-31	2023-08-30	Osisko Mining Inc.
2460309	32F01	56,36	2016-08-31	2023-08-30	Osisko Mining Inc.
2460310	32F01	56,35	2016-08-31	2023-08-30	Osisko Mining Inc.
2460311	32F01	56,35	2016-08-31	2023-08-30	Osisko Mining Inc.
2460312	32F01	56,35	2016-08-31	2023-08-30	Osisko Mining Inc.
2460313	32F01	56,35	2016-08-31	2023-08-30	Osisko Mining Inc.
2460314	32F01	56,35	2016-08-31	2023-08-30	Osisko Mining Inc.
2460315	32F01	56,35	2016-08-31	2023-08-30	Osisko Mining Inc.
2460316	32F01	56,35	2016-08-31	2023-08-30	Osisko Mining Inc.
2460317	32F01	56,35	2016-08-31	2023-08-30	Osisko Mining Inc.
2460318	32F01	56,34	2016-08-31	2023-08-30	Osisko Mining Inc.
2460319	32F01	56,34	2016-08-31	2023-08-30	Osisko Mining Inc.
2460320	32F01	56,34	2016-08-31	2023-08-30	Osisko Mining Inc.
2460321	32F01	56,34	2016-08-31	2023-08-30	Osisko Mining Inc.
2460322	32F01	56,34	2016-08-31	2023-08-30	Osisko Mining Inc.
2460323	32F01	56,34	2016-08-31	2023-08-30	Osisko Mining Inc.
2460324	32F01	56,34	2016-08-31	2023-08-30	Osisko Mining Inc.
2460325	32F01	56,34	2016-08-31	2023-08-30	Osisko Mining Inc.
2460329	32F01	56,33	2016-08-31	2023-08-30	Osisko Mining Inc.
2460330	32F01	56,33	2016-08-31	2023-08-30	Osisko Mining Inc.
2460331	32F01	56,33	2016-08-31	2023-08-30	Osisko Mining Inc.
2460332	32F01	56,33	2016-08-31	2023-08-30	Osisko Mining Inc.
2460333	32F01	56,33	2016-08-31	2023-08-30	Osisko Mining Inc.
2460334	32F01	56,33	2016-08-31	2023-08-30	Osisko Mining Inc.
2460338	32F01	56,32	2016-08-31	2023-08-30	Osisko Mining Inc.
2460339	32F01	56,32	2016-08-31	2023-08-30	Osisko Mining Inc.
2460340	32F01	56,32	2016-08-31	2023-08-30	Osisko Mining Inc.
2460341	32F01	56,32	2016-08-31	2023-08-30	Osisko Mining Inc.
2460342	32F01	56,32	2016-08-31	2023-08-30	Osisko Mining Inc.



Title	NTS	Area (ha)	Staking Date	Expiration Date	Owner (According to GESTIM)
2460343	32F01	56,32	2016-08-31	2023-08-30	Osisko Mining Inc.
2460344	32F01	56,32	2016-08-31	2023-08-30	Osisko Mining Inc.
2460355	32F01	56,34	2016-08-31	2023-08-30	Osisko Mining Inc.
2460356	32F01	56,34	2016-08-31	2023-08-30	Osisko Mining Inc.
2460357	32F01	56,34	2016-08-31	2023-08-30	Osisko Mining Inc.
2460358	32F01	56,34	2016-08-31	2023-08-30	Osisko Mining Inc.
2460359	32F01	56,34	2016-08-31	2023-08-30	Osisko Mining Inc.
2460360	32F01	56,34	2016-08-31	2023-08-30	Osisko Mining Inc.
2460361	32F01	56,34	2016-08-31	2023-08-30	Osisko Mining Inc.
2460362	32F01	56,34	2016-08-31	2023-08-30	Osisko Mining Inc.
2460363	32F01	56,34	2016-08-31	2023-08-30	Osisko Mining Inc.
2460365	32F01	56,34	2016-08-31	2023-08-30	Osisko Mining Inc.
2460368	32F01	56,34	2016-08-31	2023-08-30	Osisko Mining Inc.
2460369	32F01	56,34	2016-08-31	2023-08-30	Osisko Mining Inc.
2460370	32F01	56,34	2016-08-31	2023-08-30	Osisko Mining Inc.
2460371	32F01	56,34	2016-08-31	2023-08-30	Osisko Mining Inc.
2460372	32F01	56,34	2016-08-31	2023-08-30	Osisko Mining Inc.
2460373	32F01	56,34	2016-08-31	2023-08-30	Osisko Mining Inc.
2460374	32F01	56,34	2016-08-31	2023-08-30	Osisko Mining Inc.
2460375	32F01	56,33	2016-08-31	2023-08-30	Osisko Mining Inc.
2460376	32F01	56,33	2016-08-31	2023-08-30	Osisko Mining Inc.
2460377	32F01	56,33	2016-08-31	2023-08-30	Osisko Mining Inc.
2460378	32F01	56,33	2016-08-31	2023-08-30	Osisko Mining Inc.
2460379	32F01	56,33	2016-08-31	2023-08-30	Osisko Mining Inc.
2460380	32F01	56,33	2016-08-31	2023-08-30	Osisko Mining Inc.
2460381	32F01	56,33	2016-08-31	2023-08-30	Osisko Mining Inc.
2460382	32F01	56,33	2016-08-31	2023-08-30	Osisko Mining Inc.
2460383	32F01	56,33	2016-08-31	2023-08-30	Osisko Mining Inc.
2460390	32F01	56,33	2016-08-31	2023-08-30	Osisko Mining Inc.
2460391	32F01	56,33	2016-08-31	2023-08-30	Osisko Mining Inc.
2460392	32F01	56,33	2016-08-31	2023-08-30	Osisko Mining Inc.
2460393	32F01	56,33	2016-08-31	2023-08-30	Osisko Mining Inc.
2460394	32F01	56,33	2016-08-31	2023-08-30	Osisko Mining Inc.
2460404	32F01	56,39	2016-08-31	2023-08-30	Osisko Mining Inc.
2460405	32F01	56,39	2016-08-31	2023-08-30	Osisko Mining Inc.
2460406	32F01	56,39	2016-08-31	2023-08-30	Osisko Mining Inc.
2460407	32F01	56,38	2016-08-31	2023-08-30	Osisko Mining Inc.



Title	NTS	Area (ha)	Staking Date	Expiration Date	Owner (According to GESTIM)
2460408	32F01	56,38	2016-08-31	2023-08-30	Osisko Mining Inc.
2460409	32F01	56,38	2016-08-31	2023-08-30	Osisko Mining Inc.
2460410	32F01	56,38	2016-08-31	2023-08-30	Osisko Mining Inc.
2460411	32F01	56,38	2016-08-31	2023-08-30	Osisko Mining Inc.
2460412	32F01	56,38	2016-08-31	2023-08-30	Osisko Mining Inc.
2460413	32F01	56,38	2016-08-31	2023-08-30	Osisko Mining Inc.
2460414	32F01	56,38	2016-08-31	2023-08-30	Osisko Mining Inc.
2460415	32F01	56,38	2016-08-31	2023-08-30	Osisko Mining Inc.
2460416	32F01	56,38	2016-08-31	2023-08-30	Osisko Mining Inc.
2460417	32F01	56,38	2016-08-31	2023-08-30	Osisko Mining Inc.
2460418	32F01	56,38	2016-08-31	2023-08-30	Osisko Mining Inc.
2460419	32G04	56,39	2016-08-31	2023-08-30	Osisko Mining Inc.
2460420	32G04	56,39	2016-08-31	2023-08-30	Osisko Mining Inc.
2460421	32G04	56,38	2016-08-31	2023-08-30	Osisko Mining Inc.
2460422	32G04	56,38	2016-08-31	2023-08-30	Osisko Mining Inc.
2460423	32G04	56,38	2016-08-31	2023-08-30	Osisko Mining Inc.
2471661	32B13	56,66	2017-01-05	2024-01-04	Osisko Mining Inc.
2471662	32B13	56,66	2017-01-05	2024-01-04	Osisko Mining Inc.
2471663	32B13	56,65	2017-01-05	2024-01-04	Osisko Mining Inc.
2471664	32B13	56,65	2017-01-05	2024-01-04	Osisko Mining Inc.
2471665	32B13	56,65	2017-01-05	2024-01-04	Osisko Mining Inc.
2471666	32B13	56,65	2017-01-05	2024-01-04	Osisko Mining Inc.
2471667	32B13	56,64	2017-01-05	2024-01-04	Osisko Mining Inc.
2471668	32B13	56,64	2017-01-05	2024-01-04	Osisko Mining Inc.
2471669	32B13	56,64	2017-01-05	2024-01-04	Osisko Mining Inc.
2471670	32B13	56,64	2017-01-05	2024-01-04	Osisko Mining Inc.
2471671	32B13	56,63	2017-01-05	2024-01-04	Osisko Mining Inc.
2471672	32B13	56,63	2017-01-05	2024-01-04	Osisko Mining Inc.
2471673	32B13	56,63	2017-01-05	2024-01-04	Osisko Mining Inc.
2471674	32B13	56,63	2017-01-05	2024-01-04	Osisko Mining Inc.
2471675	32B13	56,63	2017-01-05	2024-01-04	Osisko Mining Inc.
2472018	32B13	56,55	2017-01-05	2024-01-04	Osisko Mining Inc.
2472019	32B13	56,55	2017-01-05	2024-01-04	Osisko Mining Inc.
2472020	32B13	56,55	2017-01-05	2024-01-04	Osisko Mining Inc.
2472152	32G03	56,33	2017-01-09	2024-01-08	Osisko Mining Inc.
2472153	32G03	56,33	2017-01-09	2024-01-08	Osisko Mining Inc.
2475586	32G03	56,44	2017-01-31	2024-01-30	Osisko Mining Inc.



Title	NTS	Area (ha)	Staking Date	Expiration Date	Owner (According to GESTIM)
2475587	32G03	56,38	2017-01-31	2024-01-30	Osisko Mining Inc.
2475588	32G03	56,37	2017-01-31	2024-01-30	Osisko Mining Inc.
2475589	32G03	56,36	2017-01-31	2024-01-30	Osisko Mining Inc.
2479157	32G03	56,41	2017-02-15	2024-02-14	Osisko Mining Inc.
2479158	32G03	56,41	2017-02-15	2024-02-14	Osisko Mining Inc.
2479159	32G03	56,41	2017-02-15	2024-02-14	Osisko Mining Inc.
2479160	32G03	56,41	2017-02-15	2024-02-14	Osisko Mining Inc.
2480169	32B13	56,52	2017-02-21	2024-02-20	Osisko Mining Inc.
2483699	32B13	56,63	2017-03-08	2024-03-07	Osisko Mining Inc.
2483704	32B13	56,63	2017-03-08	2024-03-07	Osisko Mining Inc.
2483705	32B13	56,63	2017-03-08	2024-03-07	Osisko Mining Inc.
2483710	32B13	56,62	2017-03-08	2024-03-07	Osisko Mining Inc.
2491514	32G04	56,40	2017-05-04	2024-05-03	Osisko Mining Inc.
2491515	32G04	56,39	2017-05-04	2024-05-03	Osisko Mining Inc.
2491516	32G04	56,39	2017-05-04	2024-05-03	Osisko Mining Inc.
2491517	32G04	56,38	2017-05-04	2024-05-03	Osisko Mining Inc.
2491518	32G04	56,38	2017-05-04	2024-05-03	Osisko Mining Inc.
2491519	32G04	56,35	2017-05-04	2024-05-03	Osisko Mining Inc.
2491520	32G04	56,35	2017-05-04	2024-05-03	Osisko Mining Inc.
2491610	32B13	56,56	2017-05-05	2024-05-04	Osisko Mining Inc.
2491611	32B13	56,55	2017-05-05	2024-05-04	Osisko Mining Inc.
2491612	32B13	56,56	2017-05-05	2024-05-04	Osisko Mining Inc.
2491613	32B13	56,55	2017-05-05	2024-05-04	Osisko Mining Inc.
2492749	32G04	56,42	2017-05-24	2024-05-23	Osisko Mining Inc.
2499643	32G04	56,38	2017-08-11	2024-08-10	Osisko Mining Inc.
2499645	32G04	56,41	2017-08-11	2024-08-10	Osisko Mining Inc.
2499646	32G04	56,41	2017-08-11	2024-08-10	Osisko Mining Inc.
2499647	32G04	56,40	2017-08-11	2023-08-10	Osisko Mining Inc.
2499648	32G04	56,39	2017-08-11	2023-08-10	Osisko Mining Inc.
2499651	32G04	56,39	2017-08-11	2024-08-10	Osisko Mining Inc.
2499653	32G04	56,40	2017-08-11	2024-08-10	Osisko Mining Inc.
2499654	32G04	56,38	2017-08-11	2024-08-10	Osisko Mining Inc.
2499655	32G04	56,45	2017-08-11	2024-08-10	Osisko Mining Inc.
2499656	32G04	56,44	2017-08-11	2024-08-10	Osisko Mining Inc.
2499660	32G03	56,35	2017-08-11	2024-08-10	Osisko Mining Inc.
2499661	32G03	56,35	2017-08-11	2024-08-10	Osisko Mining Inc.
2499684	32G04	56,43	2017-08-11	2024-08-10	Osisko Mining Inc.



Title	NTS	Area (ha)	Staking Date	Expiration Date	Owner (According to GESTIM)
2505919	32G03	56,39	2017-11-21	2024-11-20	Osisko Mining Inc.
2505921	32G03	56,40	2017-11-21	2024-11-20	Osisko Mining Inc.
2505922	32G03	56,39	2017-11-21	2024-11-20	Osisko Mining Inc.
2514697	32G03	56,41	2018-03-15	2023-03-14	Osisko Mining Inc.
2518170	32G03	56,36	2018-05-18	2023-05-17	Osisko Mining Inc.
2518171	32G03	56,35	2018-05-18	2023-05-17	Osisko Mining Inc.
2519774	32G04	56,42	2018-06-18	2023-06-17	Osisko Mining Inc.
2520781	32G03	56,34	2018-07-17	2023-07-16	Osisko Mining Inc.
2520782	32G03	56,33	2018-07-17	2023-07-16	Osisko Mining Inc.
2520783	32G03	56,33	2018-07-17	2023-07-16	Osisko Mining Inc.
2520784	32G03	56,33	2018-07-17	2023-07-16	Osisko Mining Inc.
2520785	32G03	56,33	2018-07-17	2023-07-16	Osisko Mining Inc.
2520786	32G03	56,33	2018-07-17	2023-07-16	Osisko Mining Inc.
2520787	32G03	56,33	2018-07-17	2023-07-16	Osisko Mining Inc.
2520788	32G03	56,33	2018-07-17	2023-07-16	Osisko Mining Inc.
2520789	32G03	56,33	2018-07-17	2023-07-16	Osisko Mining Inc.
2528426	32F01	56,36	2018-12-03	2023-12-02	Osisko Mining Inc.
2528427	32F01	56,36	2018-12-03	2023-12-02	Osisko Mining Inc.
2528428	32F01	56,36	2018-12-03	2023-12-02	Osisko Mining Inc.
2528429	32F01	56,35	2018-12-03	2023-12-02	Osisko Mining Inc.
2528430	32F01	56,35	2018-12-03	2023-12-02	Osisko Mining Inc.
2528431	32F01	56,35	2018-12-03	2023-12-02	Osisko Mining Inc.
2528432	32F01	56,35	2018-12-03	2023-12-02	Osisko Mining Inc.
2528433	32F01	56,35	2018-12-03	2023-12-02	Osisko Mining Inc.
2528434	32F01	56,34	2018-12-03	2023-12-02	Osisko Mining Inc.
2528435	32F01	56,34	2018-12-03	2023-12-02	Osisko Mining Inc.
2528436	32F01	56,34	2018-12-03	2023-12-02	Osisko Mining Inc.
2528437	32F01	56,34	2018-12-03	2023-12-02	Osisko Mining Inc.
2543515	32G04	56,34	2019-09-23	2023-09-22	Osisko Mining Inc.
2543516	32G04	56,33	2019-09-23	2023-09-22	Osisko Mining Inc.
2543581	32G04	56,40	2019-09-24	2023-09-23	Osisko Mining Inc.
2613330	32G03	56,40	2021-06-17	2024-06-16	Osisko Mining Inc.
2637072	32F01	56,35	2022-02-22	2025-02-21	Osisko Mining Inc.
2637073	32F01	56,35	2022-02-22	2025-02-21	Osisko Mining Inc.
2637074	32F01	56,35	2022-02-22	2025-02-21	Osisko Mining Inc.
2637075	32F01	56,34	2022-02-22	2025-02-21	Osisko Mining Inc.
2637076	32F01	56,34	2022-02-22	2025-02-21	Osisko Mining Inc.



Title	NTS	Area (ha)	Staking Date	Expiration Date	Owner (According to GESTIM)
2637077	32F01	56,34	2022-02-22	2025-02-21	Osisko Mining Inc.
2542260	32G04	56,39	2019-08-02	2023-08-01	Osisko Mining Inc.
2542261	32G04	56,39	2019-08-02	2023-08-01	Osisko Mining Inc.



Appendix C:

List of claims 2022 – Urban Duke

The following table presents the status of the claims as of October 11, 2022. All claims that have not been renewed are kilometres away from the limit of the Mineral Resource Estimate.



Title	NTS	Area (ha)	Staking Date	Expiration Date	Owner (According to GESTIM)
2369502	32G04	3.37	2012-12-03	2023-07-12	Osisko Mining Inc. 30 % / Bonterra Resources Inc. 70 %
2369503	32G04	25.53	2012-12-03	2023-07-12	Osisko Mining Inc. 30 % / Bonterra Resources Inc. 70 %
2369504	32G04	24.83	2012-12-03	2023-07-12	Osisko Mining Inc. 30 % / Bonterra Resources Inc. 70 %
2369505	32G04	15.00	2012-12-03	2023-07-12	Osisko Mining Inc. 30 % / Bonterra Resources Inc. 70 %
2369506	32G04	56.45	2012-12-03	2023-07-12	Osisko Mining Inc. 30 % / Bonterra Resources Inc. 70 %
2369507	32G04	56.44	2012-12-03	2023-07-12	Osisko Mining Inc. 30 % / Bonterra Resources Inc. 70 %
2369508	32G04	0.37	2012-12-03	2023-07-12	Osisko Mining Inc. 30 % / Bonterra Resources Inc. 70 %
2369509	32G04	1.77	2012-12-03	2023-07-12	Osisko Mining Inc. 30 % / Bonterra Resources Inc. 70 %
2369510	32G04	4.97	2012-12-03	2023-07-12	Osisko Mining Inc. 30 % / Bonterra Resources Inc. 70 %
2369511	32G04	56.44	2012-12-03	2023-07-12	Osisko Mining Inc. 30 % / Bonterra Resources Inc. 70 %
2369512	32G04	4.98	2012-12-03	2023-07-12	Osisko Mining Inc. 30 % / Bonterra Resources Inc. 70 %
2387580	32G04	56.45	2013-07-18	2023-11-10	Osisko Mining Inc. 30 % / Bonterra Resources Inc. 70 %
2387581	32G04	56.45	2013-07-18	2023-11-10	Osisko Mining Inc. 30 % / Bonterra Resources Inc. 70 %
2387582	32G04	56.45	2013-07-18	2023-11-10	Osisko Mining Inc. 30 % / Bonterra Resources Inc. 70 %
2387583	32G04	56.45	2013-07-18	2023-11-10	Osisko Mining Inc. 30 % / Bonterra Resources Inc. 70 %
2387584	32G04	56.45	2013-07-18	2023-11-10	Osisko Mining Inc. 30 % / Bonterra Resources Inc. 70 %
2387585	32G04	56.45	2013-07-18	2023-11-10	Osisko Mining Inc. 30 % / Bonterra Resources Inc. 70 %
2387586	32G04	56.45	2013-07-18	2023-11-10	Osisko Mining Inc. 30 % / Bonterra Resources Inc. 70 %
2387587	32G04	56.45	2013-07-18	2023-11-10	Osisko Mining Inc. 30 % / Bonterra Resources Inc. 70 %
2387588	32G04	56.45	2013-07-18	2023-11-10	Osisko Mining Inc. 30 % / Bonterra Resources Inc. 70 %
2387589	32G04	56.44	2013-07-18	2023-11-10	Osisko Mining Inc. 30 % / Bonterra Resources Inc. 70 %
2387590	32G04	56.44	2013-07-18	2023-11-10	Osisko Mining Inc. 30 % / Bonterra Resources Inc. 70 %
2387591	32G04	56.44	2013-07-18	2023-11-10	Osisko Mining Inc. 30 % / Bonterra Resources Inc. 70 %
2387592	32G04	56.44	2013-07-18	2023-11-10	Osisko Mining Inc. 30 % / Bonterra Resources Inc. 70 %



Title	NTS	Area (ha)	Staking Date	Expiration Date	Owner (According to GESTIM)
2387593	32G04	56.44	2013-07-18	2023-11-10	Osisko Mining Inc. 30 % / Bonterra Resources Inc. 70 %
2387594	32G04	56.44	2013-07-18	2023-11-10	Osisko Mining Inc. 30 % / Bonterra Resources Inc. 70 %
2387595	32G04	56.44	2013-07-18	2023-11-10	Osisko Mining Inc. 30 % / Bonterra Resources Inc. 70 %
2387596	32G04	56.44	2013-07-18	2023-11-10	Osisko Mining Inc. 30 % / Bonterra Resources Inc. 70 %
2387597	32G04	56.44	2013-07-18	2023-11-10	Osisko Mining Inc. 30 % / Bonterra Resources Inc. 70 %
2387598	32G04	56.44	2013-07-18	2023-11-10	Osisko Mining Inc. 30 % / Bonterra Resources Inc. 70 %
2387599	32G04	56.44	2013-07-18	2023-11-10	Osisko Mining Inc. 30 % / Bonterra Resources Inc. 70 %
2387600	32G04	56.44	2013-07-18	2023-11-10	Osisko Mining Inc. 30 % / Bonterra Resources Inc. 70 %
2387603	32G04	56.43	2013-07-18	2023-11-10	Osisko Mining Inc. 30 % / Bonterra Resources Inc. 70 %
2387604	32G04	56.43	2013-07-18	2023-11-10	Osisko Mining Inc. 30 % / Bonterra Resources Inc. 70 %
2387605	32G04	56.43	2013-07-18	2023-11-10	Osisko Mining Inc. 30 % / Bonterra Resources Inc. 70 %
2387606	32G04	56.43	2013-07-18	2023-11-10	Osisko Mining Inc. 30 % / Bonterra Resources Inc. 70 %
2387607	32G04	56.43	2013-07-18	2023-11-10	Osisko Mining Inc. 30 % / Bonterra Resources Inc. 70 %
2387608	32G04	56.43	2013-07-18	2023-11-10	Osisko Mining Inc. 30 % / Bonterra Resources Inc. 70 %
2387609	32G04	56.43	2013-07-18	2023-11-10	Osisko Mining Inc. 30 % / Bonterra Resources Inc. 70 %
2387610	32G04	56.43	2013-07-18	2023-11-10	Osisko Mining Inc. 30 % / Bonterra Resources Inc. 70 %
2387611	32G04	56.43	2013-07-18	2023-11-10	Osisko Mining Inc. 30 % / Bonterra Resources Inc. 70 %
2387620	32G04	56.42	2013-07-18	2023-11-10	Osisko Mining Inc. 30 % / Bonterra Resources Inc. 70 %
2387621	32G04	56.42	2013-07-18	2023-11-10	Osisko Mining Inc. 30 % / Bonterra Resources Inc. 70 %
2387622	32G04	56.42	2013-07-18	2023-11-10	Osisko Mining Inc. 30 % / Bonterra Resources Inc. 70 %
2387623	32G04	56.42	2013-07-18	2023-11-10	Osisko Mining Inc. 30 % / Bonterra Resources Inc. 70 %
2387624	32G04	56.42	2013-07-18	2023-11-10	Osisko Mining Inc. 30 % / Bonterra Resources Inc. 70 %
2387625	32G04	56.42	2013-07-18	2023-11-10	Osisko Mining Inc. 30 % / Bonterra Resources Inc. 70 %
2387633	32G04	56.42	2013-07-18	2023-11-10	Osisko Mining Inc. 30 % / Bonterra Resources Inc. 70 %



Title	NTS	Area (ha)	Staking Date	Expiration Date	Owner (According to GESTIM)
2387634	32G04	56.42	2013-07-18	2023-11-10	Osisko Mining Inc. 30 % / Bonterra Resources Inc. 70 %
2387650	32G04	56.44	2013-07-18	2023-11-10	Osisko Mining Inc. 30 % / Bonterra Resources Inc. 70 %
2387651	32G04	56.44	2013-07-18	2023-11-10	Osisko Mining Inc. 30 % / Bonterra Resources Inc. 70 %
2387652	32G04	56.43	2013-07-18	2023-11-10	Osisko Mining Inc. 30 % / Bonterra Resources Inc. 70 %
2387653	32G04	56.43	2013-07-18	2023-11-10	Osisko Mining Inc. 30 % / Bonterra Resources Inc. 70 %
2387656	32G04	56.45	2013-07-18	2023-11-10	Osisko Mining Inc. 30 % / Bonterra Resources Inc. 70 %
2387663	32G04	54.90	2013-07-18	2023-11-10	Osisko Mining Inc. 30 % / Bonterra Resources Inc. 70 %
2387668	32G04	39.58	2013-07-18	2023-11-10	Osisko Mining Inc. 30 % / Bonterra Resources Inc. 70 %
2387669	32G04	56.43	2013-07-18	2023-11-10	Osisko Mining Inc. 30 % / Bonterra Resources Inc. 70 %
2387670	32G04	9.54	2013-07-18	2023-11-10	Osisko Mining Inc. 30 % / Bonterra Resources Inc. 70 %
2387674	32G04	56.42	2013-07-18	2023-11-10	Osisko Mining Inc. 30 % / Bonterra Resources Inc. 70 %
2387676	32G04	39.24	2013-07-18	2023-11-10	Osisko Mining Inc. 30 % / Bonterra Resources Inc. 70 %
2387679	32G04	45.34	2013-07-18	2023-11-10	Osisko Mining Inc. 30 % / Bonterra Resources Inc. 70 %
2387680	32B13	44.58	2013-07-18	2023-11-10	Osisko Mining Inc. 30 % / Bonterra Resources Inc. 70 %
2387683	32G04	56.42	2013-07-18	2023-11-10	Osisko Mining Inc. 30 % / Bonterra Resources Inc. 70 %
2387684	32G04	0.65	2013-07-18	2023-11-10	Osisko Mining Inc. 30 % / Bonterra Resources Inc. 70 %
2387686	32G04	3.49	2013-07-18	2023-11-10	Osisko Mining Inc. 30 % / Bonterra Resources Inc. 70 %
2387688	32G04	40.40	2013-07-18	2023-11-10	Osisko Mining Inc. 30 % / Bonterra Resources Inc. 70 %
2387689	32G04	29.34	2013-07-18	2023-11-10	Osisko Mining Inc. 30 % / Bonterra Resources Inc. 70 %
2387691	32G04	55.67	2013-07-18	2023-11-10	Osisko Mining Inc. 30 % / Bonterra Resources Inc. 70 %
2387693	32B13	56.47	2013-07-18	2023-11-10	Osisko Mining Inc. 30 % / Bonterra Resources Inc. 70 %
2387694	32G04	6.04	2013-07-18	2023-11-10	Osisko Mining Inc. 30 % / Bonterra Resources Inc. 70 %
2387695	32G04	18.77	2013-07-18	2023-11-10	Osisko Mining Inc. 30 % / Bonterra Resources Inc. 70 %
2387696	32G04	6.01	2013-07-18	2023-11-10	Osisko Mining Inc. 30 % / Bonterra Resources Inc. 70 %



Title	NTS	Area (ha)	Staking Date	Expiration Date	Owner (According to GESTIM)
2387697	32G04	53.14	2013-07-18	2023-11-10	Osisko Mining Inc. 30 % / Bonterra Resources Inc. 70 %
2387698	32G04	6.32	2013-07-18	2023-11-10	Osisko Mining Inc. 30 % / Bonterra Resources Inc. 70 %
2387700	32G04	54.93	2013-07-18	2023-11-10	Osisko Mining Inc. 30 % / Bonterra Resources Inc. 70 %
2387705	32G04	6.36	2013-07-18	2023-11-10	Osisko Mining Inc. 30 % / Bonterra Resources Inc. 70 %
2387708	32G04	39.41	2013-07-18	2023-11-10	Osisko Mining Inc. 30 % / Bonterra Resources Inc. 70 %
2387709	32B13	23.47	2013-07-18	2023-11-10	Osisko Mining Inc. 30 % / Bonterra Resources Inc. 70 %
2387710	32G04	5.05	2013-07-18	2023-11-10	Osisko Mining Inc. 30 % / Bonterra Resources Inc. 70 %
2387711	32G04	48.50	2013-07-18	2023-11-10	Osisko Mining Inc. 30 % / Bonterra Resources Inc. 70 %
2431684	32G04	56.45	2015-07-29	2024-07-28	Osisko Mining Inc. 30 % / Bonterra Resources Inc. 70 %