



A gold producer in the Americas,
expanding for tomorrow

July 1, 2024





This presentation contains “forward-looking information” or “forward-looking statements” within the meaning of Canadian securities legislation. All statements included herein, other than statements of historical fact, including without limitation statements relating to: estimated production and cost guidance in 2024, targeted production and cost guidance in 2026, the 2024 exploration program and the details and objectives thereof, benefits of contract mining partners and the Company’s plans related thereto, the plant expansion at Segovia and the details and timing thereof, the Marmato Lower Mine expansion and the details and timing thereof, the potential of and plans pertaining to the Company’s growth projects, the repositioning of Aris Mining within peer group, future Soto Norte studies and the details and timing thereof, plans pertaining to the Soto Norte Project and the benefits and timing thereof, the Company’s ESG objectives, the growth potential of the Company’s projects, and the Company’s goals and objectives. Generally, the forward-looking information and forward-looking statements can be identified by the use of forward-looking terminology such as “become”, “believe”, “estimate”, “expect”, “forward”, “intend”, “plan”, “potential” or variations of such words and phrases or state that certain actions, events or results “may”, “could”, “would”, “might” or “will” be taken, “occur” or “be achieved”. Statements concerning mineral reserve estimates and mineral resource estimates may also be deemed to constitute forward looking information to the extent that they involve estimates of the mineralization that will be encountered. The material factors or assumptions used to develop forward looking information or statements are disclosed throughout this presentation.

Forward looking information and forward looking statements, while based on management’s best estimates and assumptions, are subject to known and unknown risks, uncertainties and other factors that may cause the actual results, level of activity, performance or achievements of Aris Mining to be materially different from those expressed or implied by such forward-looking information or forward looking statements, including but not limited to: local environmental and regulatory requirements and delays in obtaining required environmental and other licenses, changes in national and local government legislation, taxation, controls and regulations, political or economic developments and permits, uncertainties and hazards associated with gold exploration, development and mining, risks associated with tailings management, risks associated with operating in foreign jurisdictions, risks associated with capital cost estimates, dependence of operations on infrastructure, costs associated with the decommissioning of the Company’s properties, fluctuations in foreign exchange or interest rates and stock market volatility, operational and technical problems, the ability to maintain good relations with employees and labour unions, competition; reliance on key personnel, litigation risks, uncertainties relating to title to property and mineral resource and mineral reserve estimates, risks associated with acquisitions and integration, risks associated with the Company’s ability to meet its financial obligations as they fall due, volatility in the price of gold, or certain other commodities, risks that actual production may be less than estimated, risks associated with servicing indebtedness, additional funding requirements, risks associated with general economic factors, risks associated with secured debt, changes in the accessibility and availability of insurance for mining operations and property, environmental, sustainability and governance practices and performance, risks associated with climate change, risks associated with the reliance on experts outside of Canada, pandemics, epidemics and public health crises, potential conflicts of interest, uncertainties relating to the enforcement of civil liabilities outside of Canada, cyber-security risks, risks associated with operating a joint venture, volatility of the share price, the ability to pay dividends in the future, as well as those factors discussed in the section entitled “Risk Factors” in Aris Mining’s most recent AIF and Management’s Discussion and Analysis available on SEDAR+ at www.sedarplus.ca and in the Company’s filings with the U.S. Securities and Exchange Commission (“SEC”) at www.sec.gov.

Although Aris Mining has attempted to identify important factors that could cause actual results to differ materially from those contained in forward-looking information and forward-looking statements, there may be other factors that cause results not to be as anticipated, estimated or intended. There can be no assurance that such information or statements will prove to be accurate, as actual results and future events could differ materially from those anticipated in such information or statements. The Company has

and continues to disclose in its Management’s Discussion and Analysis and other publicly filed documents, changes to material factors or assumptions underlying the forward-looking information and forward-looking statements and to the validity of the information, in the period the changes occur.

The forward-looking statements and forward-looking information are made as of the date hereof and Aris Mining disclaims any obligation to update any such factors or to publicly announce the result of any revisions to any of the forward-looking statements or forward-looking information contained herein to reflect future results. Accordingly, readers should not place undue reliance on forward-looking statements and information.

Free cash flow, Cash costs (\$ per oz sold), AISC (\$ per oz sold), EBITDA, adjusted EBITDA, adjusted (loss)/earnings and additions to mining interests are non-IFRS financial measures and non-IFRS ratios in this document. These measures do not have any standardized meaning prescribed under IFRS, and therefore may not be comparable to other issuers. For full details on these measures and ratios refer to the Non-IFRS Measures section of the Company’s Management’s Discussion and Analysis for the three months ended March 31, 2024, which is incorporated by reference into this presentation and is available on SEDAR+ at www.sedarplus.ca and in the Company’s filings with the SEC at www.sec.gov.

Certain information contained in this presentation includes market and industry data that has been obtained from or is based upon estimates derived from third party sources. Although the data is believed to be reliable, Aris Mining has not independently verified such information and cannot provide any assurance of its accuracy, currency, reliability, or completeness.

This presentation contains information that may constitute future-orientated financial information or financial outlook information (collectively, “FOFI”) about the Company’s prospective financial performance, financial position or cash flows, all of which is subject to the same assumptions, risk factors, limitations and qualifications as set forth above. Readers are cautioned that the assumptions used in the preparation of such information, although considered reasonable at the time of preparation, may prove to be imprecise or inaccurate and, as such, undue reliance should not be placed on FOFI. The Company’s actual results, performance and achievements could differ materially from those expressed in, or implied by, FOFI. The Company has included FOFI in order to provide readers with a more complete perspective on the Company’s future operations and management’s current expectations relating to the Company’s future performance. Readers are cautioned that such information may not be appropriate for other purposes. FOFI contained herein was made as of the date of this presentation. Unless required by applicable laws, the Company does not undertake any obligation to publicly update or revise any FOFI statements, whether as a result of new information, future events or otherwise.

Qualified Person

Pamela De Mark, P. Geo, Senior Vice President Geology and Exploration for Aris Mining, is a Qualified Person under NI 43-101, and has reviewed and approved the technical contents of this presentation. All technical information related to the Segovia Operations, Marmato Mine, Soto Norte Project, Toroparu Project, and Juby Project is available at www.aris-mining.com, on SEDAR+ at www.sedarplus.ca and in the Company’s filings with the SEC at www.sec.gov.

Aris Mining – gold producer expanding for tomorrow



<p>Two mines with expansions underway</p>	<p>~230,000 oz <i>2024E consolidated production¹</i></p> <p>\$149 million in adjusted EBITDA² <i>12 month trailing from current operations</i></p>	<p><i>growing to</i></p>	<p>500,000 oz/year <i>Target H2 2026E production, following expansions³</i></p> <p>\$300+ million EBITDA⁴ <i>2026E Target</i></p>
<p>High-grade resource base</p>	<p>9.6 Moz at operating assets <i>Segovia: M&I resource of 3.6 Moz at 14.3 g/t⁵</i> <i>Marmato: M&I resource of 6.0 Moz at 3.0 g/t⁵</i></p>	<p><i>and</i></p>	<p>9.7 Moz at development projects <i>PSN: attr. indicated resources of 4.3 Moz at 5.5 g/t⁵</i> <i>Toroparu: M&I resources of 5.4 Moz at 1.5 g/t⁵</i></p>
<p>Exploration success</p>	<p>+114% to 3.6 Moz at 14.3 g/t <i>M&I resource growth in 2023 at Segovia⁵</i></p>	<p><i>and</i></p>	<p>+75% to 1.3 Moz at 11.6 g/t <i>P&P reserve growth in 2023 at Segovia⁵</i></p>
<p>Two projects for long-term growth</p>	<p>Soto Norte Project <i>51% Joint-Venture interest in 8.5 Moz^{5,6} of indicated mineral resources</i></p>	<p><i>and</i></p>	<p>Toroparu Project <i>Gold exploration and development project in western Guyana</i></p>
<p>Strong cash position \$147 million at Mar 31, 2024</p>		<p>Cash flow from operations contributing to growth funding</p>	<p>Experienced team with track record of success</p>

1. See Appendix for 2024 guidance details

2. EBITDA is a non-IFRS measure, refer to the MD&A for the periods ended December 31, 2023 and March 31, 2024 for a reconciliation of adjusted EBITDA

3. Aris Mining is targeting a production rate of 500,000 ounces of gold per year in the second half of 2026, following a ramp-up period after the Segovia mill expansion scheduled for completion in Q1 2025 and the Marmato Lower Mine's first gold pour in late 2025

4. Estimated consolidated EBITDA based on Marmato PFS and increased production following completion of Segovia plant expansion

5. See Appendix for details of technical disclosures and full disclosure of

Mineral Reserve and Mineral Resource estimates

6. 100% basis

Aris Mining is repositioning within our peer group



Aris Mining ranks near the top of peers for Mineral Resources

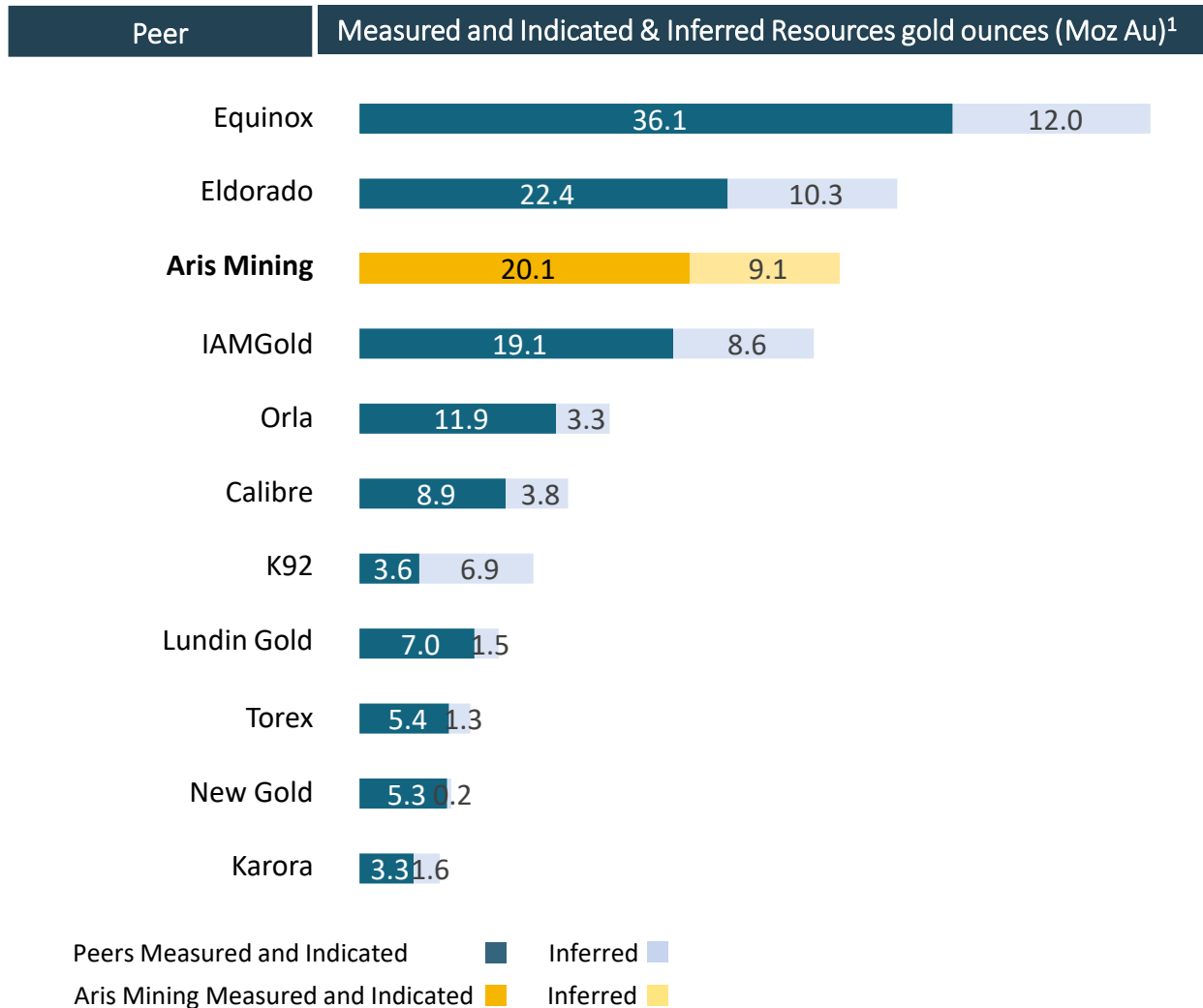

Aris Mining is climbing the ranks based on gold production

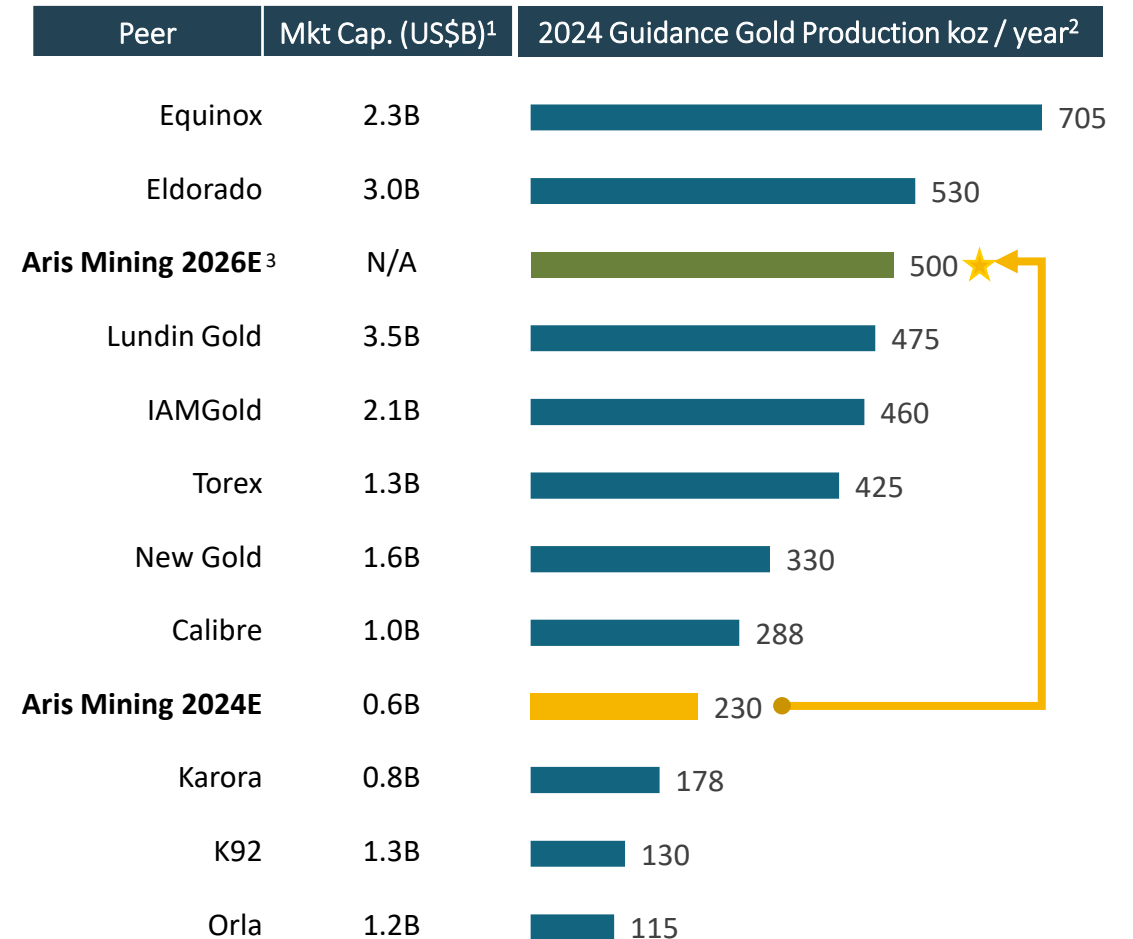

Notes:

1. Per data available in S&P Capital Markets as of June 27, 2024.
2. 2024 gold production guidance estimates used for peer companies.
3. Aris Mining is targeting a production rate of 500,000 ounces of gold per year in the second half of 2026, following a ramp-up period after the Segovia mill expansion scheduled for completion in Q1 2025 and the Marmato Lower Mine's first gold pour in late 2025



Location of our mines and development projects in Latin America

Aris Mining has a corporate office in Bogotá and an operations office in Medellín

Benefits of Colombia:

- Colombia is rich in high-grade gold deposits and is underexplored
- Colombia ranks as a Top 10 gold producer in the world based on (i) official production, (ii) unofficial production and (iii) estimates of unauthorized production – Emerging gold industry together with an active artisanal mining sector presents a sizeable collaboration opportunity
- Well-developed infrastructure
- Economic stability
- Skilled workforce
- Strategic location within Latin America



● Operating mines, with expansions underway ● Development projects ● Aris Mining offices

Segovia – ranks as a leading high-grade mine globally



Operating Mine ^{1,2}	Owner	Reserve Tonnes (kt)	Reserve Grade (Au g/t)	Contained Gold (koz)
Macassa	Agnico Eagle	5,067	13.1	2,136
Segovia³	Aris Mining	3,531	11.6	1,320
Island	Alamos Gold	5,210	10.3	1,725
Obuasi	Anglo Gold Ashanti	22,830	9.7	7,110
Mponeng	Harmony	6,000	9.2	1,779
Fruta del Norte	Lundin Gold	21,700	8.9	5,500
Pogo	Northern Star	5,867	8.6	1,618
Brucejack	Newmont	14,000	8.4	3,700
Driefontein	Sibanye Stillwater	11,600	7.9	2,900
Mayskoye	Polymetal	8,576	7.0	1,753
Red Lake	Evolution	7,740	6.9	2,748
Fosterville	Agnico Eagle	12,400	6.1	1,682

Segovia, at 11.6 g/t reserve grade³, is one of the highest-grade gold operations in the world.

Notes:

1. Per data available in S&P Capital Markets as of April 5, 2024.
2. List of high-grade operations is derived from publicly available information and is illustrative and may not be exhaustive or up to date.
3. See Appendix for details of technical disclosures and full disclosure of Mineral Reserve and Mineral Resource estimates.

Segovia – our cash flow engine, being expanded by 50%



Status quo

- 2024 guidance range of 200,000 to 220,000 oz gold production at AISC/oz of \$1,225 to \$1,325
- 1.7 million ounces gold produced since 2011 at an average grade of 12.2 g/t, since 2018 Segovia has produced approximately 200,000 ounces per year
- Reserve-only mine life extended to nearly 7 years based on 2023 production rates following 2023 interpretation changes and exploration success¹
- 2024's \$18.5M exploration program of 93,300 metres to: (1) upgrade high-grade inferred to indicated mineral resources adjacent to our active mine workings, (2) maintain a pipeline of prospective inferred resources, and (3) support our contract partner miners (CMPs)
- Primary product is a gold-silver doré and a polymetallic plant produces zinc and lead concentrates, extracting valuable metals from tailings waste

Processing Plant Expansion

- Plant to be expanded by 50%, from 2,000 tpd to 3,000 tpd from installation of ball mill and new receiving facility for Contract Mining Partners (CMPs) mined material, expected completion in early 2025
- Expected capex of \$11M for plant expansion
- Potential to gradually increase annual gold production from 200-220 koz to over 300 koz, as new capacity used by (1) increasing our mining rates and (2) providing more processing solutions for CMPs

Segovia specific KPIs:

201koz

Trailing 12 month production at Q1'24

\$1,247/oz

Trailing 12 month AISC at Q1'24²

\$139M

Trailing 12 month Free Cash Flow before growth capital and taxes at Q1'24^{2,3}

\$44M

Trailing 12 month Free Cash Flow after taxes and growth capital at Q1'24²

Notes:

1. See "Technical Disclosure and Qualified Person" in the Appendix for full disclosure of technical and scientific details.
2. Non-IFRS measure, refer to the MD&As for the period ended December 31, 2023 and March 31, 2024 for a reconciliation of AISC, free cash flow before growth capital and taxes and cash flow after taxes and growth capital for Segovia Operations.

3. Calculated as AISC margin per the MD&A, less working capital movements and foreign exchange movements.

Segovia Processing Plant Expansion – Designs

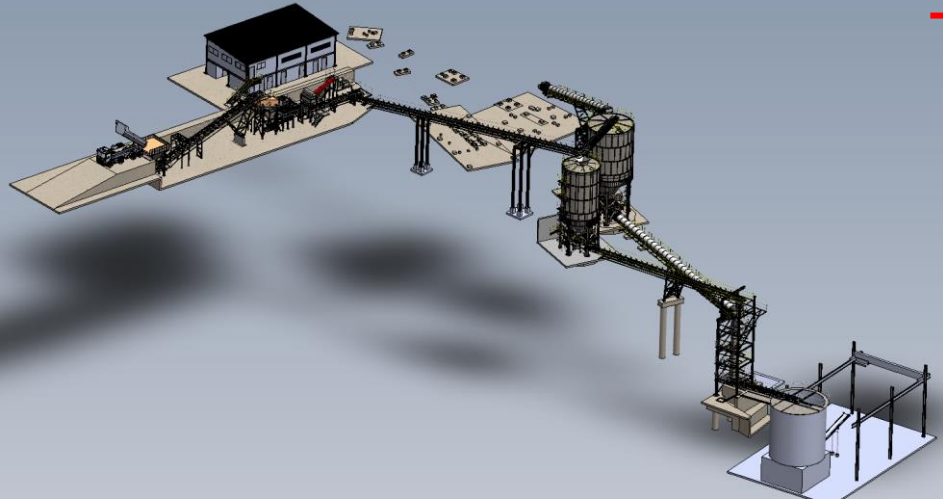
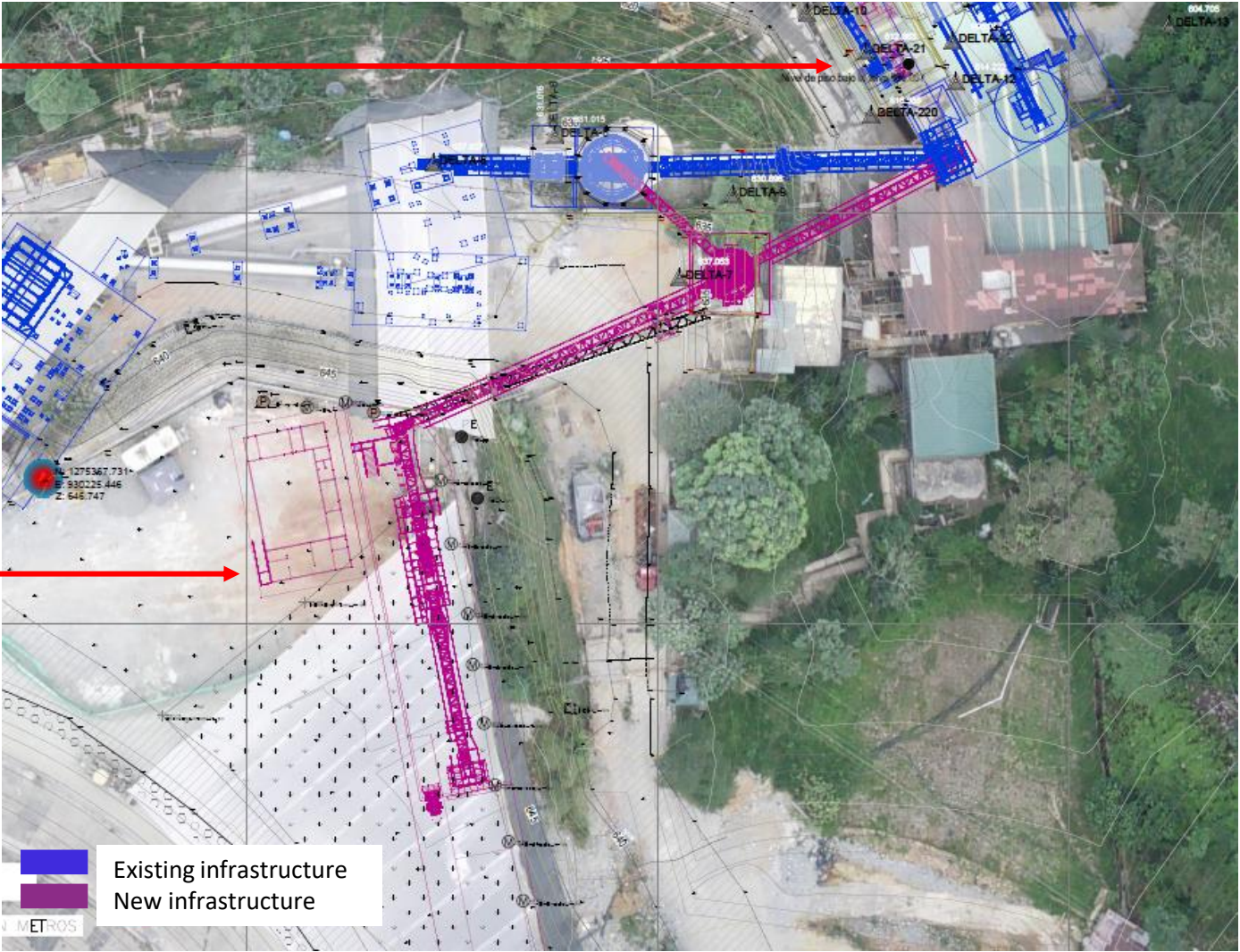
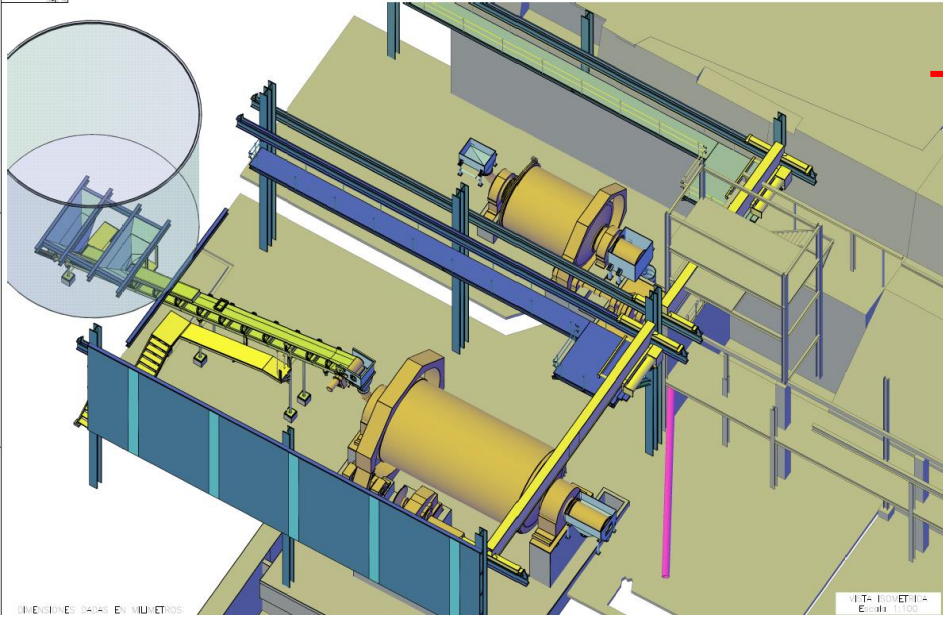

Segovia, Contract Mining Partners (CMPs) – operating model

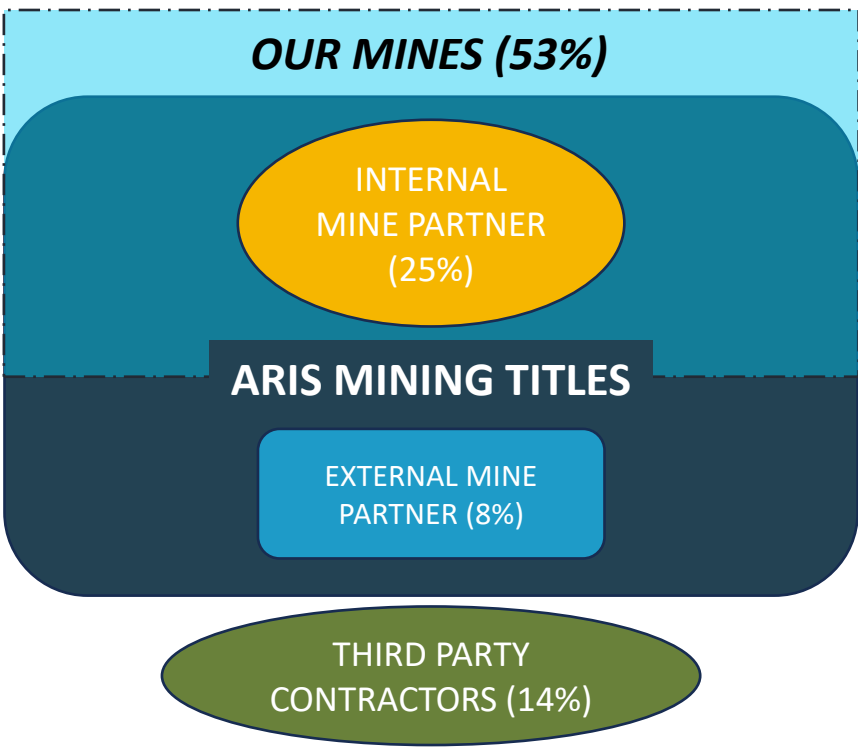
Overview	Benefits of CMP collaboration	
<p>~40-45% of production from CMPs, where cost is based on % of the US dollar gold price, ensuring a relatively fixed margin</p>	<p>Aris Mining</p>	<ul style="list-style-type: none"> • Unique opportunity to unlock and share value, our facilities recover >95% of gold versus <50% recovered by traditional methods • Profit & cash flow enhancing by using full plant capacity with high-grade mill feed from CMP • Safeguarding our social license by building partnerships
<p>Illustration of CMP collaboration¹</p>	<p>CMP</p>	<ul style="list-style-type: none"> • Concentrate on mining operations and receive payment based on a higher metallurgical recovery rate • Enter the formal economy, gaining access to legal protections, financial services, and broader market opportunities • Access to technical, operational, and safety know-how, as well as working capital financing • Access to training programs in health and safety, environmental stewardship, accounting, compliance and business management • Access to social security and other benefits
 <p>The diagram shows a large light blue box labeled 'OUR MINES (53%)'. Inside this box, there is a yellow oval labeled 'INTERNAL MINE PARTNER (25%)' and a dark blue box labeled 'ARIS MINING TITLES'. Inside the 'ARIS MINING TITLES' box, there is a smaller light blue box labeled 'EXTERNAL MINE PARTNER (8%)'. Below the 'OUR MINES' box, there is a green oval labeled 'THIRD PARTY CONTRACTORS (14%)'.</p>	<p>Government</p>	<ul style="list-style-type: none"> • Formalizing the artisanal mining sector is a priority of the current Government • Transitions artisanal miners into the formal economy, contributing to tax revenues • Enhanced safety for communities and compliance with labor laws
	<p>Environment</p>	<ul style="list-style-type: none"> • Mitigation of environmental damage (avoidance of mercury, which is used by artisanal miners to extract gold) • Responsible and efficient use of natural resources (water, etc) • Commitment to ongoing rehabilitation

Notes:
1. Contribution to 2023 production

Marmato – Transformation through Lower Mine Expansion¹



- Upper Mine currently producing ~25 koz/year; historic narrow vein mine with small scale, labour intensive mining
- The new Lower Mine will access wider porphyry mineralization and increase total production to 162 koz per year with a 20-year mine life
- Avg \$74M of net cash flow / year before tax once Lower Mine is fully operational^{1,2}
- Lower Mine is a \$280M capex project which includes building a new 4,000 tpd processing facility; construction is underway and first gold is expected in late 2025
- \$122M of capex funded by committed stream financing³

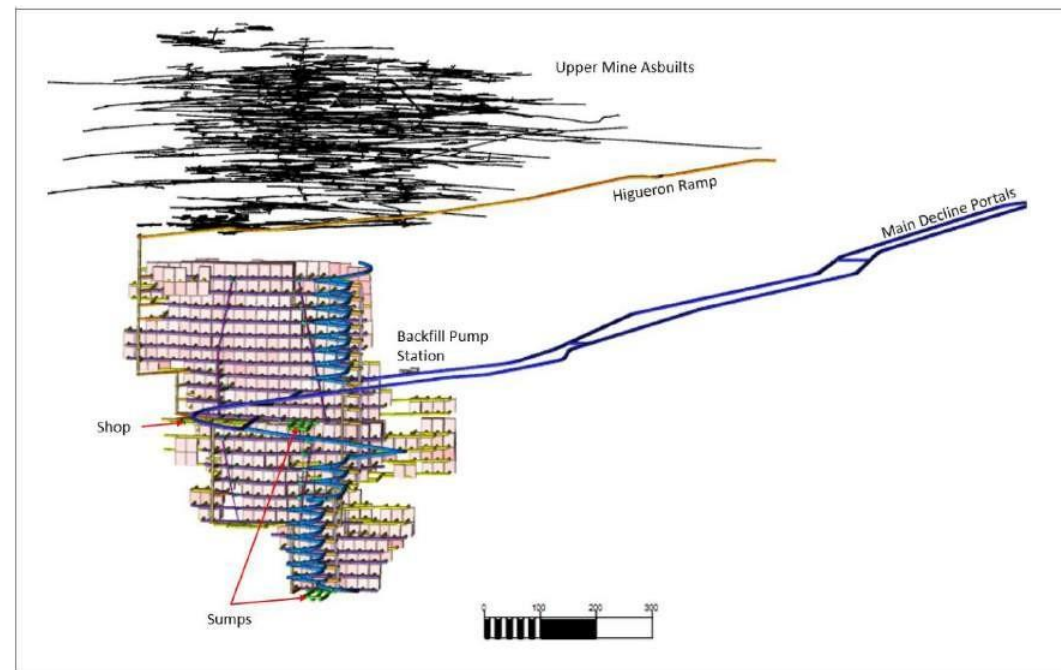
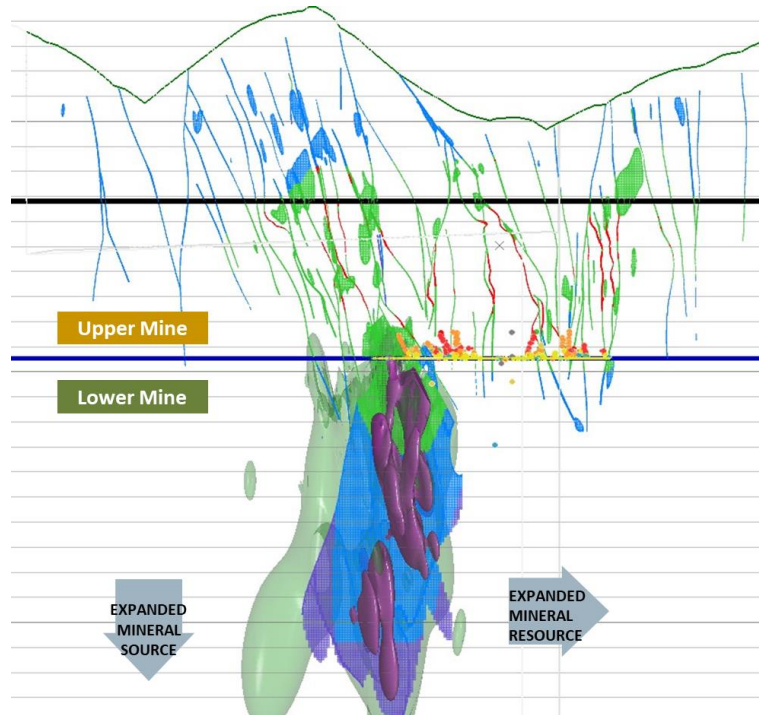

Notes:

1. Refer to the pre-feasibility study (PFS) on the Marmato Lower Mine Project with an effective date of June 30, 2022, see “Technical Disclosure and Qualified Person” in the Appendix for full disclosure of technical and scientific details.

2. Non-IFRS measure. Net cash flow defined as operating margin less sustaining and non-sustaining capex after working capital adjustments, before tax.

3. US\$122M remaining payable in three installments based on project completion: \$40M at 25% complete, \$40M at 50% complete and \$42M at 75% complete.

Marmato Lower Mine – timeline to first gold in late 2025

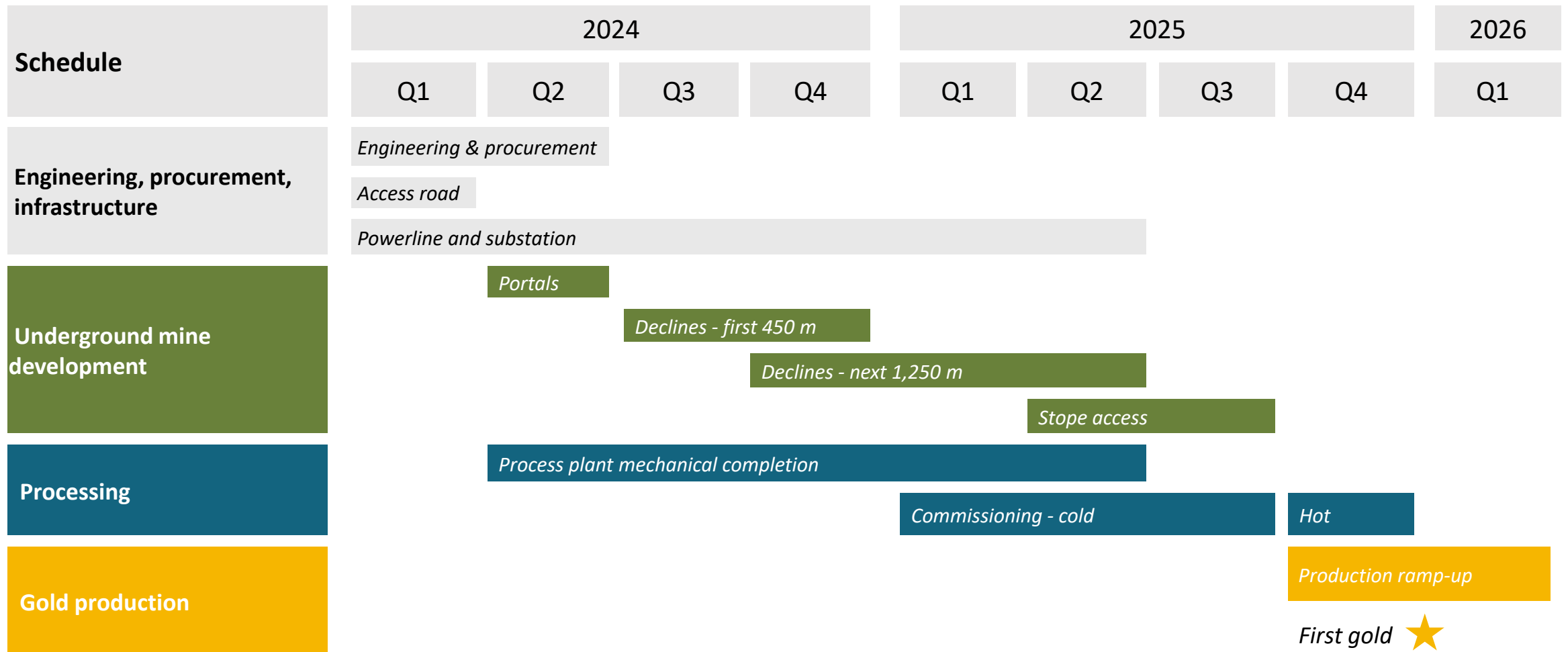

Visit [Marmato Mine - Aris Mining Corporation \(aris-mining.com\)](https://www.aris-mining.com) for visual updates on the Marmato Lower Mine construction progress.

Two additional large-scale growth projects



Soto Norte Gold-Copper Project (PSN)

- Soto Norte is a tier 1, high-grade gold asset with significant Indicated & Inferred Resources
- In June 2024, Aris Mining increased JV interest to a controlling 51%, with Mubadala retaining a 49% interest
 - Mubadala become a ~9.3% shareholder of Aris Mining, in exchange for 31% JV interest in PSN
 - Aris Mining and Mubadala have mutual right-of-first-offer (ROFO) rights, should either choose to exit the JV
 - Aris Mining is integrating the Soto Norte development team into its management structure and procedures
- Feasibility level studies underway on a new, smaller scale development plan with optimizations including a smaller environmental footprint; results are expected in early 2025

Toroparu Gold Project

- Gold exploration and development project in western Guyana
- Currently working to optimize road access routes and other site infrastructure

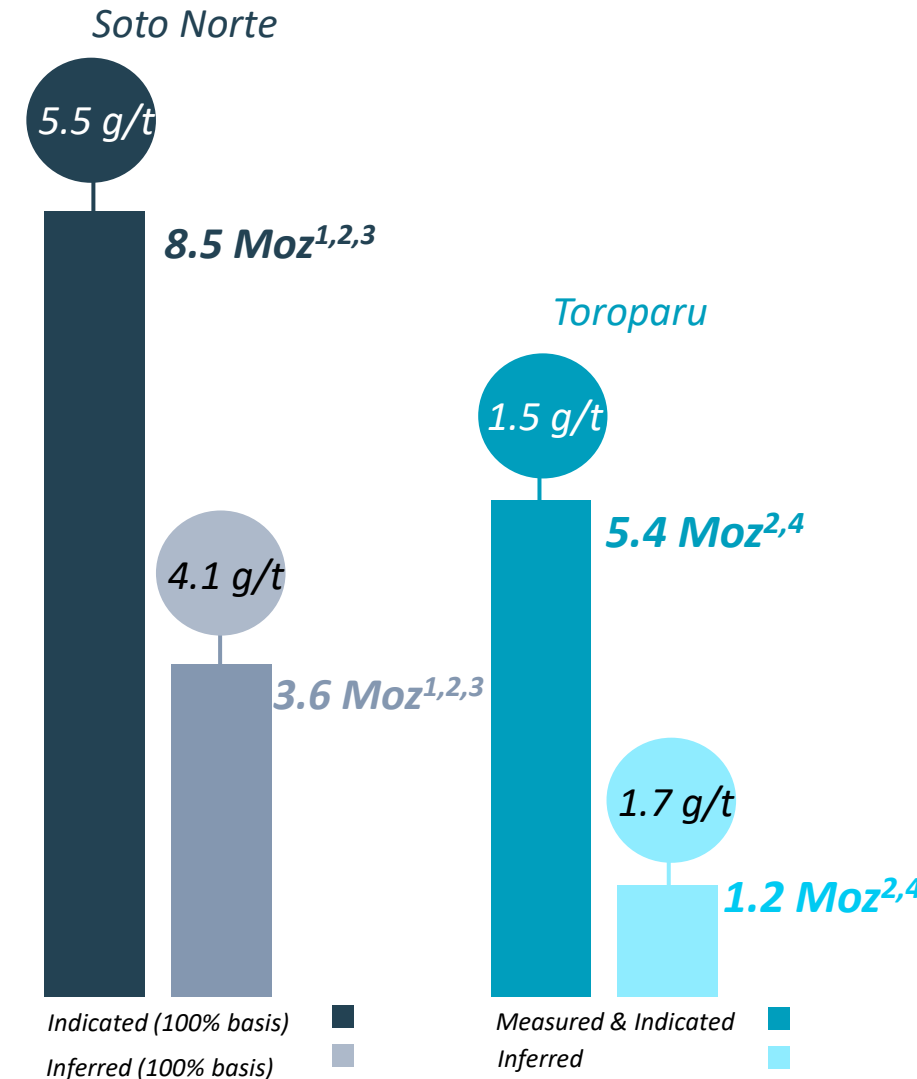

Notes: 1. Refer to the Soto Norte Technical Report with an effective date of January 1, 2021, see “Technical Disclosure and Qualified Person” in the Appendix for full disclosure of technical and scientific details.
 2. See Appendix for full disclosure of Mineral Reserve and Mineral Resource estimates and source information.
 3. Soto Norte on a 100% basis.

4. Refer to the Toroparu Technical Report with an effective date of February 10, 2023, see “Technical Disclosure and Qualified Person” in the Appendix for full disclosure of technical and scientific details.



Optimized underground mining strategy, prioritizing initial access to a higher-grade zone

- There are two main parallel mineralized zones at PSN and each has a strike length of approximately 2.0 km
- The revised mining strategy prioritizes initial access to the higher-grade zone, which can be quickly accessed from an existing portal
- The revised plan is expected to sustain a mining rate approaching 2.0 million tonnes of mill feed and waste per year

Change of mining method

- The proposed mining method is now long hole open stoping (LHOS) targeting higher grade stopes in the upper levels of the mine early in the mine life and utilizing pillars for support in the first stage of mining
- Paste backfill will be utilized in the second stage of mining while the support pillars are systematically extracted

Defer underground paste fill plant

- After installation of the paste fill plant, the mining method is proposed to change to LHOS and paste fill, to increase overall mining recovery while reducing the upfront capital requirement

Smaller processing plant

- The proposed processing plant is expected to have a 2,750 tpd capacity, approximately 60% smaller than the 2022 Feasibility Study design, with a longer operating life

Aerial ropeway to move mill feed from the existing portal to the processing plant

- A ropeway will haul mill feed to the processing plant, and move tailings from the processing plant to the underground paste fill plant
- Elimination of the 6.9 km tunnel, which was to be created by way of a tunnel boring machine (TBM), accelerating construction timelines and reducing capital costs
- Ropeway technology is currently in use in Colombia, requires minimal land use, and is easily removed at the end of the mine life



Reduced size of tailings storage facility	<ul style="list-style-type: none">• The new PSN design considers the use of process tailings as backfill in the underground stopes, significantly reducing the surface tailings storage capacity requirements and environmental footprint
Shortened construction period	<ul style="list-style-type: none">• The 2022 Feasibility Study estimated a 3.5-year construction period, with the critical path highly dependent on the TBM advance rate• The new PSN development plan will not utilize a TBM, resulting in an accelerated construction period
Environmental studies	<ul style="list-style-type: none">• The new, smaller-scale development plan is expected to reduce the environmental impact of PSN and is expected to remain mostly within the 2022 Feasibility Study project footprint covered by the existing environmental baseline studies and datasets
Páramo proximity	<ul style="list-style-type: none">• PSN remains outside the Santurbán Páramo delimitation area
Opportunity for Contract Mining Partners (CMPs)	<ul style="list-style-type: none">• Aris Mining intends to incorporate processing solutions for CMPs into the design and development of PSN, with the potential to formalize miners in the Soto Norte region in addition to Calimineros, an existing partner at PSN with about 160 miners• Aris Mining’s CMP model eliminates the use of mercury and illegal explosives by artisanal miners, creating an ecosystem that benefits CMPs, local communities, the Colombian government, the environment, and Aris Mining

Why invest in Aris Mining?



Experienced team

- Demonstrated ability to enhance operations, increase mineral resources, obtain permits and deliver construction/expansion projects
- Track record of value creation, operational excellence, financial discipline, and good corporate governance

Expanding Quality Gold Assets

- Established high-grade and profitable operations in Colombia's emerging gold industry
- Expansions at Segovia & Marmato support production target of 500,000 ounces/year in H2 2026¹
- Additional long-term production growth potential from Soto Norte and Toroparu

Smart Entry Point

- Attractive blend of current production + exploration + growth projects
- Repositioning of Aris Mining within gold producer peer group is underway

Notes:

1. Aris Mining is targeting a production rate of 500,000 ounces of gold per year in the second half of 2026, following a ramp-up period after the Segovia mill expansion scheduled for completion in Q1 2025 and the Marmato Lower Mine's first gold pour in late 2025



ARIS MINING

Appendix

Oliver Dachsel SVP Capital Markets
odachsel@aris-mining.com

Kettina Cordero VP Investor Relations
kcordero@aris-mining.com

www.aris-mining.com

info@aris-mining.com





Operation	Segovia Operations	Marmato Upper Mine
Gold production (oz)	200,000 to 220,000	20,000 – 25,000
Cash cost (US\$/oz) ¹	\$975 to \$1,075	n/a
AISC (US\$/oz) ¹	\$1,225 to \$1,325	n/a
Exploration budget (US\$ million)	\$18.5M	\$2.2M

- During 2024, Aris Mining expects consolidated gold production of between **220,000 and 240,000 oz**, with in-progress expansion projects to contribute to production growth in 2025 and beyond.

Notes:

1. Cash cost and AISC forecasts are based on a gold price of US\$2,000/oz and a USD-COP exchange rate of 3,900. Non-IFRS measure, see Slide 2 for cautionary language.



Board of Directors

Extensive mining industry experience and several Colombian business leaders

Ian Telfer, Chair

Founder and former Chair of Goldcorp (now Newmont), former Chair World Gold Council.

Neil Woodyer, CEO

Founder and former CEO of Leagold Mining and Endeavour Mining.

Daniela Cambone

Well-known financial journalist covering global markets and commodities.

Mónica de Greiff

Former Board member of the UN Global Compact and former Minister of Justice and Law in Colombia. Currently a director of Ecopetrol, Colombia's largest petroleum company.

David Garofalo

Former CEO of Goldcorp and Hudbay, former CFO of Agnico Eagle. Chair and CEO of Gold Royalty Corp.

Gonzalo Hernández Jiménez

Former Technical Vice Minister of Finance and Public Credit. Currently a director of Ecopetrol and Financiera de Desarrollo Nacional, a Colombian development bank.

Attie Roux

Experienced mining operations executive. Former COO of Endeavour Mining and Leagold Mining.

Germán Arce Zapata

Former Minister of Colombia's Mines and Energy (2016-2018) and Vice Minister of Finance (2011-2013). Former director of Colombian National Mining Agency.

Management

Experienced team with a track record of success in the mining industry

Neil Woodyer

CEO

Doug Bowlby

EVP

Richard Thomas

COO

Richard Oraziotti

CFO

Oliver Dachsels

SVP, Capital Markets

Alejandro Jimenez

Country Manager, Colombia

Ashley Baker

General Counsel and Corporate Secretary

Corné Lourens

SVP, Technical Services

Giovanna Romero

SVP, Corporate Affairs and Sustainability

Pamela De Mark

SVP, Geology and Exploration

Strategic Advisor

Frank Giustra

Mining financier, philanthropist. Co-Chair International Crisis Group

Marmato – Expanding and modernizing



Marmato is becoming a modern long-life, low-cost, 162 koz/year gold operation¹

- ✓ Historic mine with an established social license in a secure, mining-friendly region of Colombia
- ✓ Opportunity to materially expand and modernize the mine following the discovery of a large porphyry mineralized zone below the existing operation
- ✓ Strong community support with ongoing social investment commitment
- ✓ Pre-feasibility study complete with optimization studies and final engineering in progress
- ✓ Expansion financed through cash balance, operating cash flow and \$122M Wheaton Stream
- ✓ Construction started in Q3 2023

Avg \$74M of net cash flow / year before tax once Lower Mine is fully operational^{1,2}

Marmato 2022 expansion PFS highlights^{1,2}

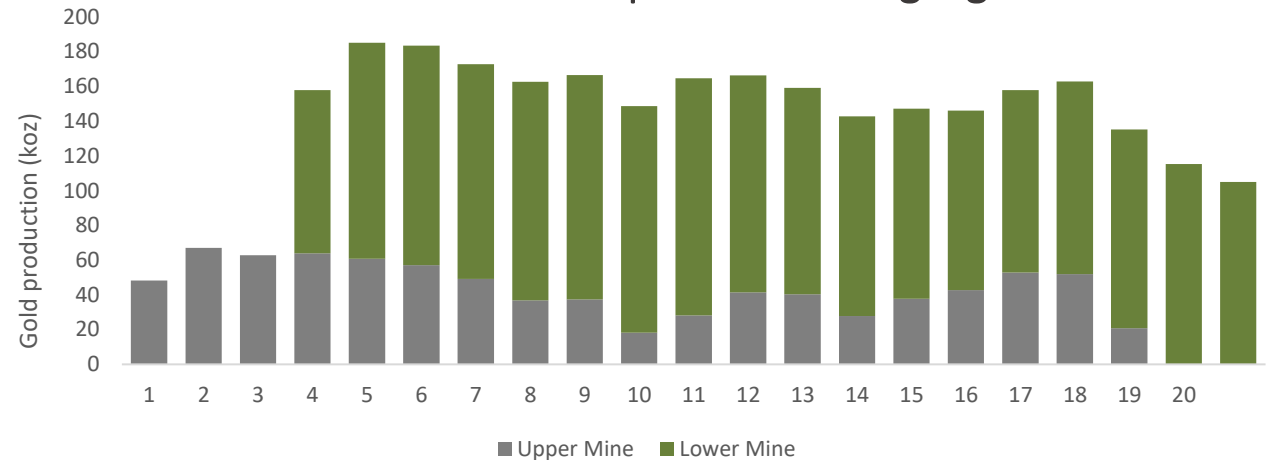

P&P gold Mineral Reserves
3.2Moz @ 3.2 g/t

M&I gold Mineral Reserves
6.0Moz @ 3.0 g/t

Inferred gold Mineral Reserves
2.8Moz @ 2.4 g/t

Total processing capacity
5,250 tpd

Gold production³
162 koz per year

Lower Mine construction capex
\$280M

AISC (LOM average)⁴
\$1,003/oz

Post-Tax IRR at \$1,600/oz
29.7%

Post-Tax NPV5% at \$1,600/oz
\$341M

Notes:

1. Refer to the PFS on the Marmato Lower Mine Project with an effective date of June 30, 2022. See Appendix for full disclosure of Mineral Reserve and Mineral Resource estimates and source information.

2. Net cash flow defined as operating margin less sustaining and non-sustaining capex after working capital adjustments, before tax.

3. Average estimated gold production from the Marmato Upper and Lower mines following construction of the Lower Mine.

4. Non-IFRS measure, see PFS on the Marmato Lower Mine Project with an effective date of June 30, 2022.

Delivering growth responsibly



Aris Mining works with local governments, communities and other stakeholders

Highlighting some of our key ESG initiatives

Communities

- Committed to social spending at both Segovia Operations and Marmato.
- Education as a key development driver: we fund the bilingual La Salada school, educating over 800 students from the Segovia area and impacting a further 2,500 in other programs.

People

- Empowering women in mining through training programs and focused recruitment.
- CMP training programs in health and safety, environmental stewardship, accounting, compliance, and business management.
- Positive union engagement, with collective bargaining agreements in full force and effect
- Vision Zerooo program to raise employee, contractor and CMP awareness in safety.

Environment

- Segovia Operations ranked as a leading global gold mine, based on low carbon emissions per ounce produced.
- Water use in Segovia Plant is 75% recycled, aiming to improve to 90% by end of 2024.
- An historic TSF at Segovia has been transformed into a community park.
- Electricity at Segovia comes from renewable sources, including hydroelectric.

Ethics & Governance

- Priorities aligned with U.N. Sustainable Development Goals (SDGs).
- Selected six SDGs to track our performance in annual reporting.
- Whistleblower and grievance mechanisms available for all of our stakeholders.

Sustainability Report

To promote our ongoing commitment to transparency and social responsibility Aris Mining publishes a sustainability report available at www.aris-mining.com



Strong financial position to fund growth



Share Capital Structure as of June 27, 2024

	<i>Current</i>
Issued and outstanding shares ¹	169.2M
Share price – as of June 27, 2024	C\$5.21 / US\$3.77
Market capitalization (issued share basis)	C\$882M / US\$638M
Cash balance (as at March 31, 2024)	US\$147M
Shares issuable on exercise of options & warrants	38.7M
Potential proceeds, exercise of options & warrants	C\$205M / US\$150M
Fully diluted shares	208M

Exchange-traded Debt

	<i>ISIN ID</i>	<i>Principal (US\$M)²</i>	<i>Maturity</i>
Senior Unsecured 6% ³ Notes (Singapore exchange), Rated B+ by S&P and Fitch	USC41069AA01 USC38501DAR6	300.0	Aug 9, 2026
Gold-Linked Secured 7½% ³ Notes (Cboe Canada exchange)	CA04041BAA67	51.2	Aug 26, 2027

Exchange Traded Warrants

	<i>Outstanding Warrants</i>	<i>Effective exercise price</i>	<i>Potential proceeds</i>	<i>Expiry</i>
ARIS.WT.A	58.1M ³	C\$5.50 ³	C\$160M / US\$117M	Jul 29, 2025

Other Share Purchase Warrants

Unlisted Warrants – tranche 1	0.8M	C\$4.03 ⁴	C\$3.3M / US\$2.4M	Aug 27, 2024
Unlisted Warrants – tranche 2	1.7M	C\$6.00 ⁵	C\$9.9M / US\$7.2M	Dec 31, 2024

Notes:

- Does not include the additional 6,000,000 contingent shares issuable to Mubadala on receipt of the environmental license to develop PSN – refer to news release dated June 28, 2024 for details.
- Principal amounts outstanding as of March 31, 2024.
- Two Aris Mining Holdings Corp. warrants can be exercised to acquire one Aris Mining common share

3. (cont.) for an aggregate exercise price of C\$5.50 per Aris Mining common share. The acceleration terms were removed pursuant to the terms of the Third Supplemental Warrant Indenture made as of the 26th day of September 2022.

4. Each share purchase warrant is converted to Aris Mining shares purchase warrants at a ratio of 0.6948:1.

5. Two Aris Mining Holdings Corp. warrants can be exercised to acquire one Aris Mining common share for an aggregate exercise price of C\$6.00 per Aris Mining common share.

Marmato US\$175M streaming agreement



- \$122M remaining payable in three ~\$40M installments based on 25%, 50% and 75% project completion
- Stream of 10.5% of Au production, with step-down to 5.25% and 100% of Ag production, with step-down to 50%.
- WPMI pays 18% of the spot gold and silver prices with step up to 22% of spot prices once the initial deposit is repaid.



NYSE Closing Bell Ceremony - January 22, 2024

Aris Mining – asset portfolio summary¹



	Segovia	Marmato	Soto Norte	Toroparu	Juby	Total (Attributable)
Location	Colombia	Colombia	Colombia	Guyana	Canada	
Ownership (%)	100%	100%	51%	100%	100%	
Gold production 2024 guidance	200-220 koz	20-25 koz	-	-	-	220-240 koz
Estimated production (Life of mine average)	+300 koz ²	162 koz ³	-	-	-	Target of ~500 koz ²
AISC⁵	\$1,225 to 1,325/oz ⁶	\$1,003/oz	-	-	-	
Reserves (Contained Au, Au grade)	1.3 Moz at 11.6 g/t	3.2 Moz at 3.2 g/t	2.5 Moz ⁴ at 6.2 g/t	-	-	7.0 Moz ⁴
M&I resources (Contained Au, Au grade)	3.6 Moz at 14.3 g/t	6.0 Moz at 3.0 g/t	4.3 Moz ⁴ at 5.5 g/t	5.4 Moz at 1.5 g/t	0.7 Moz at 1.1 g/t	20.1 Moz ⁴
Inferred resources (Contained Au, Au grade)	1.8 Moz at 12.1 g/t	2.8 Moz at 2.4 g/t	1.8 Moz ⁴ at 4.1 g/t	1.2 Moz at 1.7 g/t	1.5 Moz at 1.0 g/t	9.1 Moz ⁴

1. See Appendix for full disclosure of technical information and Mineral Reserve and Mineral Resource estimates.

2. Estimated consolidated 2026 annual production in H2 2026, based on Marmato PFS and increased production following completion of Segovia plant expansion.

3. Estimated Lower Mine life of mine; refer to the PFS on the Marmato Lower Mine Project with an effective date of June 30, 2022, see Appendix for full source details.

4. Soto Norte at Aris Mining's 51% attributable basis..

5. AISC is a non-IFRS measure; see slide 2 for cautionary language.

6. Segovia 2024 AISC guidance based on gold price of US\$2,000/oz and USD-COP exchange rate of 3,900 assumptions.

Aris Mining mineral reserves & resources



Property	Proven			Probable			Proven & Probable		
	Tonnes (kt)	Gold grade (g/t)	Contained gold (koz)	Tonnes (kt)	Gold grade (g/t)	Contained gold (koz)	Tonnes (kt)	Gold grade (g/t)	Contained gold (koz)
Marmato	2,196	4.31	304	29,082	3.08	2,874	31,277	3.16	3,178
Soto Norte (51%)	-	-	-	12,631	6.22	2,525	12,631	6.22	2,525
Segovia	1,515	12.25	597	2,017	11.16	723	3,531	11.63	1,320
Total			901			6,122			7,023

Notes: Totals may not add due to rounding. Mineral reserve estimates for Soto Norte represent the portion of mineral reserves attributable to Aris Mining based on its 51% ownership interest. Mineral reserves were estimated using a gold price of US\$1,500 per ounce at Marmato, US\$1,300 at Soto Norte, and US\$1,700 at Segovia. The mineral reserve effective dates are June 30, 2022 at Marmato, January 1, 2021 at Soto Norte, and September 30, 2023 at Segovia. This disclosure of mineral reserve estimates has been approved by Pamela De Mark, P.Geol, Senior Vice President Geology and Exploration of Aris Mining, who is a Qualified Person as defined by National Instrument 43-101.

Property	Measured			Indicated			Measured & Indicated			Inferred		
	Tonnes (Mt)	Gold grade (g/t)	Contained gold (koz)	Tonnes (Mt)	Gold grade (g/t)	Contained gold (koz)	Tonnes (Mt)	Gold grade (g/t)	Contained gold (koz)	Tonnes (Mt)	Gold grade (g/t)	Contained gold (koz)
Marmato	2.8	6.04	545	58.7	2.89	5,452	61.5	3.03	5,997	35.6	2.43	2,787
Soto Norte (51%)	-	-	-	24.5	5.47	4,312	24.5	5.47	4,312	13.9	4.06	1,821
Segovia	4.1	14.31	1,893	3.8	14.38	1,736	7.9	14.34	3,629	4.7	12.11	1,823
Toroparu	42.4	1.45	1,975	72.6	1.46	3,398	115.0	1.50	5,373	21.2	1.71	1,168
Juby	-	-	-	21.3	1.13	773	21.3	1.13	773	47.1	0.98	1,488
Total			4,413			15,671			20,084			9,087

Notes: Mineral resources are not mineral reserves and do not have demonstrated economic viability. Mineral resource estimates are reported inclusive of mineral reserves. Totals may not add due to rounding. Mineral resource estimates for Soto Norte represent the portion of mineral resources attributable to Aris Mining based on its 51% ownership interest. Mineral resources were estimated using a gold price of US\$1,700 per ounce at Marmato, US\$1,300 at Soto Norte, US\$1,850 at the Segovia Operations, US\$1,650 at Toroparu, and US\$1,450 at Juby. The mineral resource effective dates are June 30, 2022 at Marmato, May 29, 2019 at Soto Norte, September 30, 2023 at Segovia, February 10, 2023 at Toroparu, and July 14, 2020 at Juby. This disclosure of mineral resource estimates has been approved by Pamela De Mark, P.Geol, Senior Vice President Geology and Exploration of Aris Mining, who is a Qualified Person as defined by National Instrument 43-101.



Unless otherwise indicated, the scientific disclosure and technical information included in this presentation are based upon information included in the NI 43-101 compliant technical reports entitled:

1. “Technical Report for the Marmato Gold Mine, Caldas Department, Colombia, PFS of the Lower Mine Expansion Project” dated November 23, 2022 with an effective date of June 30, 2022 (the 2022 Marmato Pre-Feasibility Study). The 2022 Marmato Pre-Feasibility Study was prepared by Ben Parsons, MAusIMM (CP), Anton Chan, Peng, Brian Prosser, PE, Joanna Poeck, SME-RM, Eric J. Olin, SME-RM, MAusIMM, Fredy Henriquez, SME, ISRM, David Hoekstra, PE, NCEES, SME-RM, Mark Allan Willow, CEM, SME-RM, Vladimir Ugorets, MMSA, Colleen Crystal, PE, GE, Kevin Gunesch, PE, Tommaso Roberto Raponi, P.Eng, David Bird, PG, SME-RM, and Pamela De Mark, P.Geo., each of whom is a “Qualified Person” as such term is defined in NI 43-101, and with the exception of Pamela De Mark of Aris Mining, are independent of Aris Mining within the meaning of NI 43-101. The 2022 Marmato Pre-Feasibility Study is available for download on Aris Mining's website at www.aris-mining.com and on Aris Mining's SEDAR+ profile at www.sedarplus.ca and in Aris Mining's filings with the SEC at www.sec.gov.
2. “NI 43-101 Technical Report Feasibility Study of the Soto Norte Gold Project, Santander, Colombia”, dated March 21, 2022 with an effective date of January 1, 2021 (the Soto Norte Technical Report). The Soto Norte Technical Report was prepared by Ben Parsons, MSc, MAusIMM (CP), Chris Bray, BEng, MAusIMM (CP), and Dr John Willis PhD, BE (MET), MAusIMM (CP), and Dr Henri Sangam, Ph.D., P.Eng., each of whom is independent of Aris Mining within the meaning of NI 43-101 and is a “Qualified Person” as such term is defined in NI 43-101. The report was also prepared by Robert Anderson, P.Eng., a Qualified Person who is considered non-independent of Aris Mining. The Soto Norte Technical Report is available for download on Aris Mining's website at www.aris-mining.com and on Aris Mining Holdings Corp's (Aris Holdings) SEDAR+ profile at www.sedarplus.ca and in Aris Mining's filings with the SEC at www.sec.gov. Aris Holdings is a subsidiary of Aris Mining.
3. “NI 43-101 Technical Report for the Segovia Operations, Antioquia, Colombia” dated December 5, 2023 with an effective date of September 30, 2023 (the Segovia Technical Report). The Segovia Technical Report was prepared by Pamela De Mark, P.Geo., Inivaldo Diaz, CP and Cornelius Lourens, FAusIMM, each of whom is a “Qualified Person” as such term is defined in NI 43-101 and Cornelius Lourens was independent of Aris Mining within the meaning of NI 43-101 as of the date of the Segovia Technical Report. The Segovia Technical Report is available for download on Aris Mining's website at www.aris-mining.com and on Aris Mining's SEDAR+ profile at www.sedarplus.ca and in Aris Mining's filings with the SEC at www.sec.gov.
4. “Updated Mineral Resource Estimate NI 43-101 Technical Report for the Toroparu Project, Cuyuni-Mazaruni Region, Guyana” dated March 31, 2023 with an effective date of February 10, 2023 (the Toroparu Technical Report). The Toroparu Technical Report was prepared by Ekow Taylor, FAusIMM (CP), Maria Muñoz, MAIG, and Karl Haase, P.Eng., each of whom is independent of Aris Mining within the meaning of NI 43-101 and is a “Qualified Person” as such term is defined in NI 43-101. The Toroparu Technical Report is available for download on Aris Mining's website at www.aris-mining.com and on Aris Mining's SEDAR+ profile at www.sedarplus.ca and in Aris Mining's filings with the SEC at www.sec.gov.
5. “Technical Report on the Updated Mineral Resource Estimate for the Jubu Gold Project, Tyrrell Township, Shining Tree Area, Ontario” dated October 5, 2020 with an effective date of July 14, 2020 (the Jubu Technical Report). The Jubu Technical Report was prepared by Joe Campbell, B.Sc., P.Geo., Alan Sexton, M.Sc., P.Geo., Duncan Studd, M.Sc., P.Geo. and Allan Armitage, Ph.D., P.Geo., each of whom is independent of Aris Mining within the meaning of NI 43-101 and is a “Qualified Person” as such term is defined in NI 43-101. The Jubu Technical Report is available for download on Aris Mining's website at www.aris-mining.com and on Aris Holding's SEDAR+ profile at www.sedarplus.ca and in Aris Mining's filings with the SEC at www.sec.gov.