



NI 43-101 TECHNICAL REPORT
for the Mineral Resources Estimation
of the Miller Project 2022 update, Grenville, Quebec
Canada Carbon Inc.

Prepared by:

SGS Canada Inc.

Marc-Antoine Laporte, M.Sc., P.Ge

Yann Camus, P.Eng

SGS Canada – Geological Services

Issues Date:

December 30, 2022

Effective Date:

November 8, 2022

9 **Geological Services**

10 boul. de la Seigneurie Est, Suite 203, Blainville, Quebec Canada, J7C3V5

t (450) 433 1050 f (450) 433 1048 www.sgs.com
Member of SGS Group (SGS SA)

Disclaimer:

This document is issued by SGS Canada Inc. under its General Conditions of Service accessible at [http://www.sgs.com/terms and conditions.htm](http://www.sgs.com/terms_and_conditions.htm) . Attention is drawn to the limitation of liability, indemnification and jurisdiction issues defined therein. Any holder of this document is advised that information contained herein reflects the Company's findings at the time of its intervention only and within the limits of the Client's instructions, if any. The Company's sole responsibility is to its Client and this document does not exonerate parties to a transaction from exercising their rights and obligations under the transaction documents. Any unauthorized alteration, forgery or falsification of the content or appearance of this document is unlawful and offenders may be prosecuted to the fullest extent of the law.

Table of Content

1	EXECUTIVE SUMMARY	15
2	INTRODUCTION.....	18
2.1	UNITS AND ABBREVIATIONS.....	18
3	RELIANCE ON OTHER EXPERTS	19
4	PROPERTY DESCRIPTION AND LOCATION	20
4.1	LOCATION	20
4.2	PROPERTY DESCRIPTION.....	4-20
4.3	OWNERSHIP	4-20
4.4	RESTRICTIONS	4-22
5	ACCESSIBILITY, CLIMATE, LOCAL RESOURCES, INFRASTRUCTURE AND PHYSIOGRAPHY 5-	
24		
5.1	ACCESS	5-24
5.1.1	<i>Miller Property</i>	5-24
5.2	CLIMATE	5-24
5.3	LOCAL RESOURCES AND INFRASTRUCTURES	5-24
5.4	PHYSIOGRAPHY.....	5-25
6	HISTORY.....	6-27
6.1	2016 PRELIMINARY ECONOMIC ASSESSMENT	6-28
7	GEOLOGICAL SETTING AND MINERALIZATION.....	7-31
7.1	REGIONAL GEOLOGY	7-31
7.2	LOCAL GEOLOGY.....	7-32
7.2.1	<i>Marbles</i>	7-35
7.2.2	<i>Skarns</i>	7-36

7.2.3 *Paragneiss* 7-36

7.2.4 *Meta-arkose* 7-37

7.2.5 *Dykes* 7-37

7.2.6 *Breccia* 7-37

7.2.7 *Pegmatite* 7-37

7.3 MINERALIZATION 7-40

7.3.1 *Graphite Mineralization* 7-40

7.3.1.1 Wollastonite Pods 7-40

7.3.1.2 Banded Graphite Formation 7-40

7.3.1.3 Graphite Pods (Marble) 7-40

7.3.1.4 Disseminated Graphite (Marble) 7-40

7.3.1.5 Disseminated Graphite (Skarn) 7-41

7.3.1.6 Graphite Veins 7-41

7.3.2 *Marble* 7-42

8 DEPOSIT TYPE 8-43

8.1 GRAPHITE 8-43

8.1.1 *Disseminated Graphite* 8-43

8.1.2 *Banded Graphite* 8-44

8.1.3 *Graphite Pods Associated with Restites* 8-44

8.1.4 *Vein-type Graphite* 8-44

8.2 MARBLE ARCHITECTURAL STONE 8-44

9 EXPLORATION 9-45

9.1 INITIAL PROSPECTING WORK 9-45

9.2 GEOPHYSICS..... 9-46

 9.2.1 *Ground Electromagnetic (2013)*..... 9-46

 9.2.2 *Airborne Versatile Time-domain Electromagnetic Survey (2013)* 9-46

 9.2.3 *IMAGEM Survey (2013)*..... 9-48

 9.2.4 *PhiSpy Survey (2013)*..... 9-49

 9.2.5 *PhiSpy Survey E1 (2014)* 9-49

 9.2.6 *IP Survey (2014–2015)*..... 9-51

 9.2.7 *VN1-2*..... 9-55

 9.2.8 *VN3*..... 9-56

 9.2.9 *VN4*..... 9-57

 9.2.10 *VN6*..... 9-57

 9.2.11 *VN7*..... 9-59

 9.2.12 *VN8*..... 9-59

 9.2.13 *VN9*..... 9-59

 9.2.14 *Anomalies EM-16 and EM-17*..... 9-59

 9.2.15 *Anomaly EM-22* 9-60

 9.2.16 *Anomalies EM-22 and EM-23*..... 9-60

 9.2.17 *Anomaly E3-19* 9-60

9.3 CHANNEL SAMPLING..... 9-60

 9.3.1 *VN1– VN2*..... 9-61

 9.3.2 *VN4*..... 9-61

 9.3.3 *VN6*..... 9-61

9.3.4 VN8 9-62

9.3.5 Marble 9-63

9.4 BULK SAMPLING 9-65

10 DRILLING 10-67

10.1 DRILLING CAMPAIGN, JULY 2013..... 10-70

10.2 DRILLING CAMPAIGN, NOVEMBER 2013..... 10-71

10.3 DRILLING CAMPAIGN, 2014..... 10-72

10.4 DRILLING CAMPAIGN, AUGUST 2014 10-72

10.5 DRILLING CAMPAIGN, SEPTEMBER 2014..... 10-72

10.6 DRILLING CAMPAIGN, OCTOBER 2014 10-72

10.7 DRILLING CAMPAIGN, NOVEMBER 2014..... 10-73

10.8 DRILLING CAMPAIGN, FEBRUARY 2015..... 10-73

10.9 DRILLING CAMPAIGN, JAN-FEB 2016..... 10-73

10.10 DRILLING CAMPAIGN SUMMER 2017..... 10-73

10.11 DRILLING CAMPAIGN NOV-DEC 2021 10-73

10.12 CHANNEL SAMPLES 10-74

11 SAMPLE PREPARATION, ANALYSIS AND SECURITY..... 11-75

11.1 SAMPLE PREPARATION 11-75

 11.1.1 Core Drilling Sampling..... 11-76

 11.1.2 Channel Sampling..... 11-76

11.2 QA/QC..... 11-77

11.3 VERIFICATION OF THE QA/QC DATA..... 11-77

 11.3.1 Blank Material Results 11-78

11.3.1.1 Blank Material between the 2013 and 2017 drill campaign..... 11-78

11.3.1.2 Blank Material 2021 drill campaign 11-78

11.3.2 Duplicate Material Results 11-79

11.3.3 Standard Material Results 11-80

11.4 QA/QC OBSERVATIONS AND CONCLUSIONS 11-83

12 DATA VERIFICATION 12-84

12.1 DRILLING DATABASE..... 12-84

12.2 CONTROL SAMPLING 12-88

12.3 CONCLUSION..... 12-91

13 MINERAL PROCESSING AND METALLURGICAL TESTING 13-92

13.1 INTRODUCTION 13-92

13.2 GRAPHITE 13-92

13.2.1 Head Sample Chemical Analysis..... 13-92

13.2.2 Grindability Test..... 13-92

13.2.3 Flotation Concentration Test..... 13-93

13.2.3.1 Batch Flotation Test..... 13-93

13.2.4 Concentrate Upgrading Tests..... 13-110

13.2.4.1 Hydrometallurgical Upgrading..... 13-110

13.2.4.2 Alkaline Roasting + Hydrofluoric Acid Leaching..... 13-111

13.2.4.3 Thermal Upgrading 13-113

13.2.5 Other Graphite Characterization Tests 13-115

13.3 MARBLE 13-118

13.4 CONCLUSIONS..... 13-118

14 MINERAL RESOURCES ESTIMATION.....	14-120
14.1 DATABASE	14-120
14.2 GEOLOGICAL MODEL	14-122
14.3 MINERALIZED INTERVALS AND MINERALIZED SOLIDS	14-126
14.4 COMPOSITING OF ASSAYS.....	14-129
14.4.1 <i>Graphite Mineralization</i>	14-129
14.5 GEOSTATISTICS AND VARIOGRAPHY	14-130
14.5.1.1 GraphiteLG Variable	14-132
14.5.1.2 GraphiteHG Variable.....	14-133
14.5.1.3 Indicator Variable	14-134
14.6 DENSITY	14-137
14.7 BLOCK MODEL	14-138
14.7.1 <i>Search Ellipsoids</i>	14-139
14.8 BLOCK MODEL INTERPOLATION	14-139
14.8.1 <i>Graphite Mineralization Interpolation</i>	14-140
14.9 BLOCK MODEL CLASSIFICATION	145
14.10 OPTIMIZATION PROCEDURES AND PARAMETERS	148
14.11 MINERAL RESOURCES	150
14.11.1 <i>Graphite Resources</i>	150
15 ADJACENT PROPERTIES.....	15-151
16 INTERPRETATIONS AND CONCLUSIONS.....	16-152
16.1 MINERAL RESOURCES	16-152
17 RECOMMENDATIONS.....	17-154

18 REFERENCES..... 156

19 QUALIFICATION CERTIFICATES..... 159

 19.1 QUALIFICATION CERTIFICATE – MARC-ANTOINE 159

 19.2 QUALIFICATION CERTIFICATE – YANN CAMUS 160

APPENDIX 1: CLAIM LIST..... 161

List of Figures

Figure 4-1: Property Location 4-22

Figure 4-2: Claim Block Location and Access 4-23

Figure 4-3: Restrictions Affecting the Miller Property 4-23

Figure 5-1: Average Yearly Weather in the Project Area 5-25

Figure 6-1: Mineralization Found in the Historic Miller Mine Wall 6-28

Figure 7-1: Regional Geological Map 7-32

Figure 7-2: Regional Geology Map over the Project Area with Mapping Point Observations 7-35

Figure 7-3: Typical Rock Units Found on the Property 7-39

Figure 7-4: Typical Types of Mineralization Found on the Property..... 7-42

Figure 7-5: Typical White Marble Found on the Property 7-42

Figure 9-1: Miller Property Airborne TDEM Anomaly Map 9-47

Figure 9-2: IMAGEM Anomalies Map (2016 Pit Outline) 9-48

Figure 9-3: Ground TDEM PhiSpy Interpretation over Airborne TDEM 9-50

Figure 9-4: Resistivity and IP Interpretation over Airborne TDEM on the southern IP grid 9-52

Figure 9-5: Resistivity and IP Interpretation over Airborne TDEM on the northern IP grid 9-53

Figure 9-6: Location of Showings 9-54

Figure 9-7: Example of a Trenched Area with Banded Mineralization at VN6 9-55

Figure 9-8: Preliminary Mapping of VN6 from Vertical Photos..... 9-58

Figure 9-9: Location of Channel Samples 9-61

Figure 10-1: Location of Drillholes..... 10-68

Figure 10-2: Core Storage Area on Site..... 10-69

Figure 10-3: Example of Drillhole Markers 10-70

Figure 10-4: Example of Channel Sample Witness (left) and Channel (right) 10-74

Figure 11-1: Laboratory Results for Blank Samples 11-78

Figure 11-2: Laboratory Results for Blank Material 2021..... 11-79

Figure 11-3: Laboratory Results for the Duplicate Samples 2013-2017 11-80

Figure 11-4: Laboratory Results for the Standard Samples..... 11-82

Figure 11-5: Laboratory Results for the GCC-07 Standard Samples 11-82

Figure 12-1: Holes DDH15-86, 87 and 88 as Found in the Database (Top) and in the Field (Bottom) . 12-88

Figure 12-2: Independent Sampling : Scatter / QQ Plot / Differences Histogram..... 12-90

Figure 12-3: Independent Sampling: Difference per Grade 12-90

Figure 13-1: Conceptual Flowsheet for Miller Graphite Mineralization (14185-003, Test F7) 13-95

Figure 13-2: Flowsheet for Plant Runs from PP-08 to PP-22 13-100

Figure 13-3: Reagent Consumption – Pilot Plant Runs 13-101

Figure 13-4: Carbon Recovery vs. Carbon Grade –Combined Graphite Concentrate 13-102

Figure 13-5: Final Concentrate Mass Distribution by Size Fraction 13-103

Figure 13-6: Final Concentrate Grades by Size Fraction..... 13-104

Figure 13-7: Final Cleaner Concentrate Grade Profiles from Grab Samples 13-106

Figure 13-8: Combined Concentrate Grade Profile (+48, +65, and +80 mesh) 13-108

Figure 13-9: Combined Concentrate Grade Profile (+100, +150, -200 and +200 mesh)..... 13-108

Figure 13-10: Raman Spectrum from a Flake of Miller Graphite 13-116

Figure 13-11: Scanning Electron Microscope Images 13-117

Figure 14-1: Drillhole Collar Positioning 14-121

Figure 14-2: Topographic Surface where Resources are Modelled with Miller Property 14-121

Figure 14-3 Topographic Surface where Resources are Modelled with Drillhole Collars 14-122

Figure 14-4: Magnetic Inversion with Surface Geology Points 14-123

Figure 14-5: Magnetic Susceptibility of the Different Rock Types 14-124

Figure 14-6: Modelled Contact between Marbles (+Skarn) and Arkose-Paragneiss 14-124

Figure 14-7: Sectional Interpretation of the Marble Unit 14-125

Figure 14-8: Interpretation of Key Paragneiss Bands within the Marble Unit. 14-125

Figure 14-9: Graphitic Carbon Value Distribution for all Rock Types..... 14-126

Figure 14-10: 3D Isocontours Model of the Graphite Mineralization..... 14-127

Figure 14-11: Mineralized Solid for Graphite..... 14-128

Figure 14-12: Assays Length Statistics 14-129

Figure 14-13: Graphite Composite set with paragneiss host rock 14-130

Figure 14-14: Statistical Distribution of Graphite Values..... 14-131

Figure 14-15: GraphiteLG Statistics and Variographic Model..... 14-133

Figure 14-16: Graphite HG Statistics and Variographic Model 14-135

Figure 14-17: Indicator Statistics and Variographic Model..... 14-136

Figure 14-18: Statistical Distribution of the Density Measurements..... 14-137

Figure 14-19: Block Model Used for Interpolation (≥ 0.45 % Cg Model) 14-138

Figure 14-20: Search Ellipsoids..... 14-139

Figure 14-21: Block Model Images - GraphiteLG (Top), Indicator (Middle) and GraphiteHG (Bottom)14-142

Figure 14-22: Resulting CgTOTAL Interpolation Result..... 14-143

Figure 14-23: Validation of block model on sections..... 14-144

Figure 14-24: Results from the Block Model Validation Process 145

Figure 14-25: Surface Map of the Classified Block Model with Drill Hole Collars 148

Figure 14-26: Optimized Pit Shell from the Graphite Scenario 149

List of Tables

Table 5-1: Summary of Lachute Weather Station Climate..... 5-26

Table 9-1: Channels and Grab Samples for the VN's 9-62

Table 9-2: Marble Channels 9-64

Table 10-1..... 10-67

Table 12-1: 2022 Visit GPS and Compass Verification of 13 Collars (Suspicious Values in Colors) 12-86

Table 12-2: Raw 2022 Geode GPS data vs Database 12-86

Table 12-3: 2017 Visit GPS and Compass Verification of 33 Collars (Suspicious Values in Colors) 12-87

Table 12-4: Mineralized Interval Comparison between Canada Carbon and SGS..... 12-89

Table 13-1: Head Grade Analysis 13-92

Table 13-2: Size Fraction Analysis of 10th Cleaner Concentrate (14185-001 F2) 13-93

Table 13-3: Size Fraction Analysis Results for Test F7 (14185-003)..... 13-96

Table 13-4: Size Fraction Analysis of Combined Concentrate for 0.53% Graphitic Carbon Feed Sample (14185-005, F2) 13-97

Table 13-5: Head Assay – Pilot Plant Test Composite 13-98

Table 13-6: Average Particle Size of Feed Streams 13-99

Table 13-7: Total Carbon Assay on Different Size Fractions of Combined Concentrate from Eight Surveys 13-105

Table 13-8: Results of Analysis of Combined Concentrate by Leco and GDMS 13-109

Table 13-9: Acid Leaching Test Conditions..... 13-110

Table 13-10: Acid Leaching Test Results..... 13-111

Table 13-11: Alkaline Roasting + Hydrofluoric Acid Leaching Test Conditions 13-111

Table 13-12: Alkaline Roasting + Hydrofluoric Acid Leaching Test Results 13-111

Table 13-13: Alkaline Roasted Concentrate Fraction Assay Results by GDMS..... 13-113

Table 14-1: General Statistics of the Graphite Composites 14-131

Table 14-2: Block Model Grid Parameters 14-138

Table 14-3: Block Model Interpolation Parameters 14-140

Table 14-4: Graphite Mineral Resources Open Pit Optimization Parameters 149

Table 14-5: Graphite Mineral Resources 150

Table 17-17-1: Estimated Budget for Geological Recommendations 154

1 EXECUTIVE SUMMARY

Canada Carbon Inc. (“Canada Carbon”) retained SGS Canada Inc. (“SGS”) to prepare this resources estimation technical report under the National Instrument 43-101 (NI 43-101) format for the Miller Graphite Project (the Project), located in the developed Outaouais region of southern Quebec, Canada. This study is intended to assist Canada Carbon in determining potential future plans for the Project, and the approach to high-purity graphite production.

The effective date of this report is November 8, 2022 and the effective date of the Mineral Resource estimate is November 8, 2022.

The Miller Property is composed of 54 contiguous claims located on the eastern side of the Rouge River and covers an area of 3,244.93 ha. Canada Carbon is the 100% owner of the claims. SL Exploration Inc. has been conducting exploration work on the Miller Property since its acquisition. The 17 claims on the western side of the Rouge River that make up the Miller West Property and 6 other claims located further to the west belonging to Canada Carbon are not included in this report.

The Miller Property is located in the well-developed Outaouais region of southern Quebec, approximately 75 km west of Montreal, Quebec, and 90 km east of Ottawa, Ontario. The approximate geographic centre of the Miller Property is located at 530,385 m east and 5,056,900 m north. The closest communities are Grenville, Quebec (5 km south of the Property to the south), and Hawkesbury, Ontario (8 km south of the Property to the south). The Project Miller Property is located within the boundaries of the Argenteuil Regional County Municipality and is within the territory of Grenville-sur-la-Rouge Municipality.

All-year access roads are available to access the Project site. The site is easily accessible from Highway 50, which runs approximately 2 km south of the Property deposit boundary. Highway 50 is a provincial road linking the greater Montreal area to the greater Ottawa area. A railroad passes through the Ottawa Valley near the town of Grenville.

A local paved road, Scotch Road, traverses the Miller Property from south to north. The Miller Property is accessible from Scotch Road via a network of bush trails, which run more or less east to west. Many existing forestry roads are present in, and around the Miller Property, which allow alternate access routes.

The Project area lies in the Grenville Geological Province, which is recognized as a deeply exhumed Mesoproterozoic Himalayan-type collision orogenic belt that extends over thousands of kilometres and is interpreted as a collage of gneissic terranes that were subjected to high-grade metamorphism. The Project area is included in the south portion of the Morin Terrane, composed of supracrustal rocks, commonly at granulite metamorphic facies, and intruded by several bodies of granitic to anorthositic composition. The well-banded quartzo-feldspathic gneisses were divided into two groups and quartzites were documented as very massive, well-jointed, white or pinkish rocks. Crystalline limestone (marble) appeared to correspond

to two large beds. Graphite is observed as dissemination and pods/veins in the marble, skarn, and paragneiss units of the Miller Property. Several pods and veins have been identified and explored by Canada Carbon. Canada Carbon has discovered multiple new graphite mineralized showings. These include nine high-grade surface graphite showings, and large, lower-grade disseminations of graphite in marble and skarn units.

Canada Carbon performed a number of drilling campaigns between 2013 and 2021. The different drilling campaigns were designed to test geophysical targets (conductors), to extend identified surface graphite mineralization to depth, and to provide core samples for mineral resource estimation. A total of 348 drill holes and channels were conducted on the Miller Property to date.

The Mineral Resource estimate was conducted following the Canadian Institute of Mining, Metallurgy and Petroleum (CIM) Definitions Standards for Mineral Resources in accordance with NI 43-101 Standards of Disclosure for Mineral Projects. Mineral Resources, which are not Mineral Reserves, do not have demonstrated economic viability. Inferred Mineral Resources are exclusive of the Indicated Mineral Resources. The Mineral Resource estimation work for the Project was conducted by Marc-Antoine Laporte, P.Geo, M.Sc., of SGS. The 3D modelling was performed using Leapfrog© and geostatistics, and grade interpolation of the block model was conducted using Genesis© software. The optimized pit shell and cut-off grade estimation were conducted by SGS using updated parameters from the Miller Project Preliminary Economic Assessment (PEA) published by TetraTech, which was filed to SEDAR April 14, 2016.

Cut-off Grade (%Cg)	Resource Category	Tonnage* (Mt)	Average Grade (%Cg)	Contained Graphite (t)
0.50	Indicated	3,338,000	0.75	25,200
0.50	Inferred	10,478,000	0.72	75,400

Notes: The mineral resource estimate has been conducted using the CIM Definitions Standards for mineral resources in accordance with National Instrument 43-101, Standards of Disclosure for Mineral Projects. Mineral Resources, which are not mineral reserves, do not have demonstrated economic viability. Inferred mineral resources are exclusive of the Indicated resources.
 A fixed density of 2.81 t/m³ was used to estimate the tonnage from block model volumes.
 The results from the pit optimization are used solely for the purpose of testing the “reasonable prospects for economic extraction” by an open pit and do not represent an attempt to estimate mineral reserves. There are no mineral reserves on the Property. The results are used as a guide to assist in the preparation of a Mineral Resource statement and to select an appropriate resource reporting cut-off grade
 Resources are constrained by the pit shell and the topography of the overburden layer
 All figures are rounded to reflect the relative accuracy of the estimate and numbers may not add due to rounding
 The estimate of Mineral Resources may be materially affected by environmental, permitting, legal, title, taxation, socio-political, marketing and other relevant issues
 Effective date November 8th, 2022

Five flotation metallurgical test programs were conducted on samples originating from the Miller Deposit, covering a range of head grades from 0.53% graphitic carbon to 61.2% graphitic carbon. The five programs consisted of four laboratory scale evaluations including a flowsheet development program and one pilot plant campaign processing approximately 127 t of a bulk sample.

The laboratory and pilot scale flotation programs demonstrated that the Miller graphite mineralization is amenable to processing using typical mineral processing technologies such as grinding and flotation. A simple reagent regime consisting of fuel oil no. 2 as the graphite collector and methyl isobutyl carbinol (MIBC) as the frother proved suitable to achieve good graphite concentrate grades and overall carbon recoveries.

The laboratory and pilot scale programs produced graphite concentrates that consistently exceeded combined concentrate grades of 95% total carbon. The majority of the impurities reported to the small size fractions and the medium and large graphite flakes yielded concentrate grades of approximately 97% total carbon or higher. This metallurgical performance was consistent for all samples tested despite the large range of head grades.

The pilot plant campaign reached steady state operation in a short period of time, thus attesting to the overall robustness of the proposed flowsheet. The pilot plant campaign helped to identify a number of areas for optimization to further enhance the metallurgical results.

Preliminary graphite concentrate upgrading tests, including hydrometallurgical and thermal purification, were conducted on graphite flotation concentrates that were generated on a laboratory or pilot scale. The flotation concentrate samples responded well to both purification processing methods, although the samples yielded higher purities with the thermal treatment. The thermal purification tests employing a proprietary thermal treatment process indicate that a graphite concentrate produced from the pilot plant trials can be directly upgraded to a high-purity specialty graphite containing 99.9998% graphitic carbon.

A block of marble weighing approximately 1 t was extracted and shipped to a local architectural stone processor for cutting, polishing, and assessment. There are no detailed physical and chemical characteristic test work reports available from this review.

Based on the results of this report, it is recommended that Canada Carbon continue with the next phase of the Project, determined by the Company to be a Feasibility Study, in order to better identify economic opportunities and to further assess the Project's viability.

A detailed list of recommendations, along with the estimated costs to execute each recommendation, is outlined in Section 17.

2 INTRODUCTION

In July 2018, Canada Carbon retained SGS Canada Inc. (hereafter “SGS”) to complete a resource update Technical Report under the NI 43-101 format for the Miller Project, located in Grenville Township, Quebec.

This technical report on resource estimation provides the reader with a thorough review of the exploration activities and the independent resource estimation carried out by SGS based on 316 holes totaling more than 12,130 meters and a total of 9605 assay results for graphitic carbon, as well as a quality control program.

This report was requested by Mr. Ellerton Castor (current CEO) at Canada Carbon. The author and qualified person met regularly with Canada Carbon staff by telephone and at the Grenville site. Canada Carbon provided the necessary technical data in electronic and paper format. The author visited the Miller Project site on October 7-8, 2016, on August 1st, 2018 and on December 9 2022.

This technical report has been prepared in accordance with industry best practices as described by the Canadian Institute of Mining, Metallurgy and Petroleum (CIM) "Best Practices and Reporting Guidelines" for the disclosure of mineral exploration information, The Canadian Securities Regulators Revised Regulation 43-101 (Disclosure Standards for Mining Projects), Supplemental Instrument 43-101 and the CIM Definitions and Standards for Mineral Resources and Mineral Reserves (December 11, 2005, November 2011).

The effective date of this report is November 8, 2022 and the effective date of the Mineral Resource estimate is November 8, 2022.

2.1 Units and Abbreviations

All units of measurement used in this technical report are in metric.

All currency is in Canadian dollars, unless otherwise noted.

3 RELIANCE ON OTHER EXPERTS

Marc-Antoine Laporte, P.Geo., M.Sc., relied on:

1. Steven Lauzier, P.Geo., Consultant Geologist of Canada Carbon on matters relating to:
 - mineral tenure and mining rights permits and surface rights
 - pricing and unverifiable parameters for open pit optimization scenario

2. Jianhui (John) Huang, Ph.D., P.Eng. on:
 - summary of the metallurgical work presented in section 13 of the report
 - pit optimization parameters.

4 PROPERTY DESCRIPTION AND LOCATION

4.1 Location

The Miller Property is located in the Outaouais Region of southern Quebec about 75 km west of Montreal, Quebec and 90 km east of Ottawa, Ontario (Figure 4-1). The Miller Property is located in a highly accessible area of the Quebec province; the closest cities are Grenville (5 km to the south) and Hawkesbury, Ontario (8 km to the south). The Miller Property is easily accessible from Highway 50, which runs on the southern part of the Property, and Scotch Road, which traverses the Miller Property from south to north (Figure 4-2). Highway 50 is a provincial road linking the greater Montreal area to the greater Ottawa area. The immediate vicinity of the Property is thinly populated and the settlements are mainly concentrated along Scotch Road with relatively limited local traffic. The deposit is accessible from Scotch Road via a network of bush trails, which run more or less east-west. Many existing forestry roads are also present in and around the Miller Property, which allow alternate access routes. The Property is located within the boundaries of the Argenteuil Regional County Municipality and is within the territory of Grenville-sur-la-Rouge Municipality.

4.2 Property Description

The Miller Property is located within the National Topographic Series (NTS) Map references 31G10. The approximate geographic centre of the Miller Property is located at 530,385 m east and 5,056,900 m north, Zone 18.

The Miller Property is composed of 54 contiguous claims located on the eastern side of the Rouge River and covers an area of 3,244.93 ha. The surface footprint for the proposed optimized pits, processing plant and infrastructure utilizes 100 ha of the Miller Property with the exploration work conducted to-date limited to 29 ha of that area. The 15 claims on the western side of the Rouge River that make up the Miller West Property and 6 others claims located further to the West are not included in the report.

4.3 Ownership

The Miller Property is 100% held by Canada Carbon and exploration work has been conducted by SL Exploration Inc. since its acquisition. SGS verified the Miller Property title and mineral rights on the Ministère de l'Énergie et des Ressources Naturelles's (MERN) website. The 54 claims associated with the Property, as registered with the MERN, are 100% owned by Canada Carbon and are in good standing with expiry dates ranging from May 10, 2023 to December 8, 2024.

In September 2013, Canada Carbon entered into a surface access agreement (the Agreement) with two landholders who are affiliated with each other. The Agreement provides Canada Carbon with surface access for an initial period of five years and allows Canada Carbon to carry out regular graphite

prospecting and exploration programs including, but not limited to, conducting topographic, geological, geochemical and geophysical surveys, conducting underground or surface excavations, exploration and drilling, digging and trenching, and obtaining and testing geochemical or metallurgical samples. The Agreement covers most of the area of interest on which Canada Carbon is working at this time. The Agreement grants Canada Carbon an exclusive and irrevocable option to acquire from the landholder all or part of the Miller Property deemed reasonably necessary for the extraction of mineral substances. If Canada Carbon exercises this option, by either acquiring or leasing all or part of the Miller Property prior to the expiry of the five-year term, the term will be extended through the period of commercial production.

Pursuant to the Agreement, Canada Carbon has agreed to issue 40,000 common shares in the capital of Canada Carbon to the landholders for the first year of the term, and for each subsequent year of the term and until Canada Carbon begins operating in commercial operation (not including milling for the purposes of testing, e.g. pilot plant testing), either 40,000 additional common shares or \$5,000 payable in cash, at the option of the landholder. Should Canada Carbon begin commercial production during the term, the payments outlined above will cease and the landholder will be entitled to a 2.5% net smelter royalty (NSR) upon and subject to the terms of definitive royalty agreements. The NSR is applicable to all mineral commodities, including marble.

The initial acquisition of Miller claims from 9228-6202 Quebec Inc. (nine claims) included a 2% net production return (NPR) that was later reduced to 1.5% with an exchange of 100,000 shares. The NPR is applicable to graphite production only and is not applicable to other mineral extraction or production (e.g. marble). This claimed land has been explored for potential graphite and marble values to date and hosts the major discoveries.

Canada Carbon acquired five claims from Nouveau-Monde Mining Enterprises Inc. (Nouveau-Monde). Two Nouveau-Monde claims are currently pending due to exploration restrictions and will be transferred once the MERN allows it. Canada Carbon has also granted Nouveau-Monde a 2% NSR royalty which can be reduced at any time to 1% by paying \$1,000,000 to Nouveau-Monde.

Eight claims (4.8 km²) belonging to Caribou King were acquired. The latter claims are subject to an existing 2% net of processed material returns royalty in favor of a third party, which can be reduced at any time to 1% by paying \$1,000,000 to the royalty holder. Canada Carbon also entered into agreements with Marksman Geological Ltd. to purchase 14 other claims. The NSR is applicable to all mineral commodities, including marble. The Project is not located on any of the claims acquired from Caribou King or Marksman Geological Ltd.

Certain claims, designated in the claims list located in Appendix 1, are limited by a fauna habitat conservation area and hydroelectric lines that pass through the Miller Property (Figure 4-2). Other than those listed in the claims list (Appendix 1), there are no other encumbrances on the Property.

4.4 Restrictions

The Miller Property is located on private land and the surface right owners must be kept informed about upcoming exploration programs. Additionally, Canada Carbon must obtain their permission before initiating any exploration program. Canada Carbon has been meeting these requirements successfully to date and maintains an open and positive relationship with the land owners.

Four land category statuses' can be found in the Grenville area (Figure 4-3). Certain restrictions may be imposed on exploration activities:

- Large areas dedicated to resort and recreational activities (“territoire affecté à la villégiature”) that are not available for map staking: land affected by those restrictions surrounds and limits the staking play.
- Ecological reserve areas where exploration is prohibited: the Rivière-Rouge ecological reserve occupy small areas on the west side of the Rouge River.

Wildlife habitat areas in which activities are forbidden (with exceptions) to any activities that can modify a biological, physical or chemical component associated with the habitat (only applicable to public land): a large area of white-tailed deer (*Odocoileus virginianus*) habitat overlaps a large part of the Miller Property. The restriction is however not applicable to the Project’s exploration work because this particular area is on private land.



Figure 4-1: Property Location

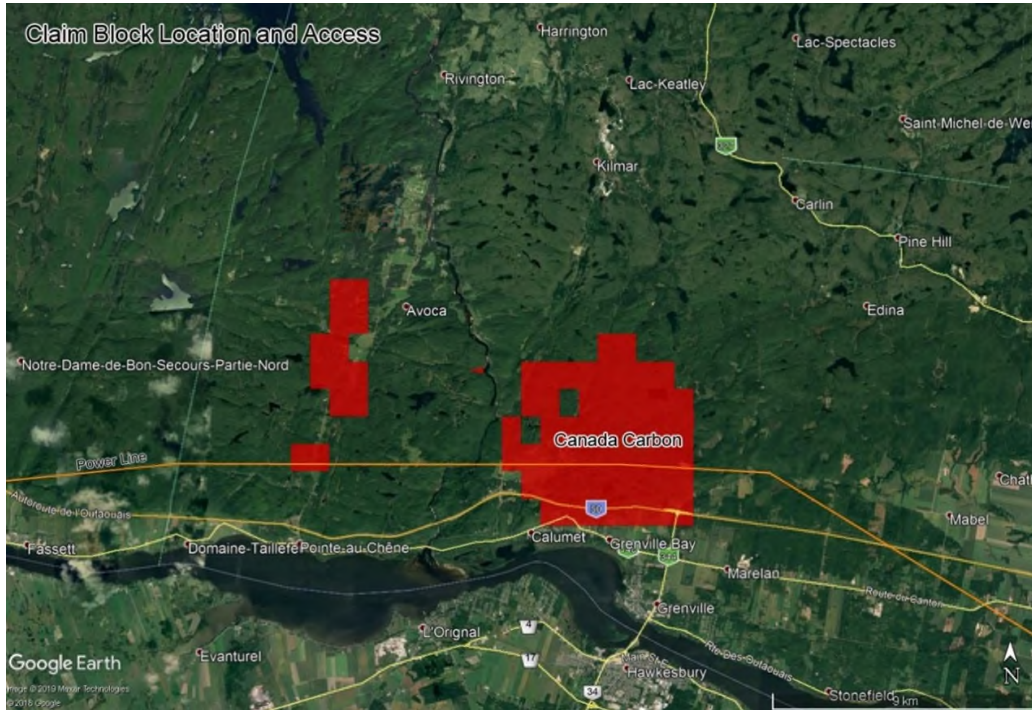

Figure 4-2: Claim Block Location and Access

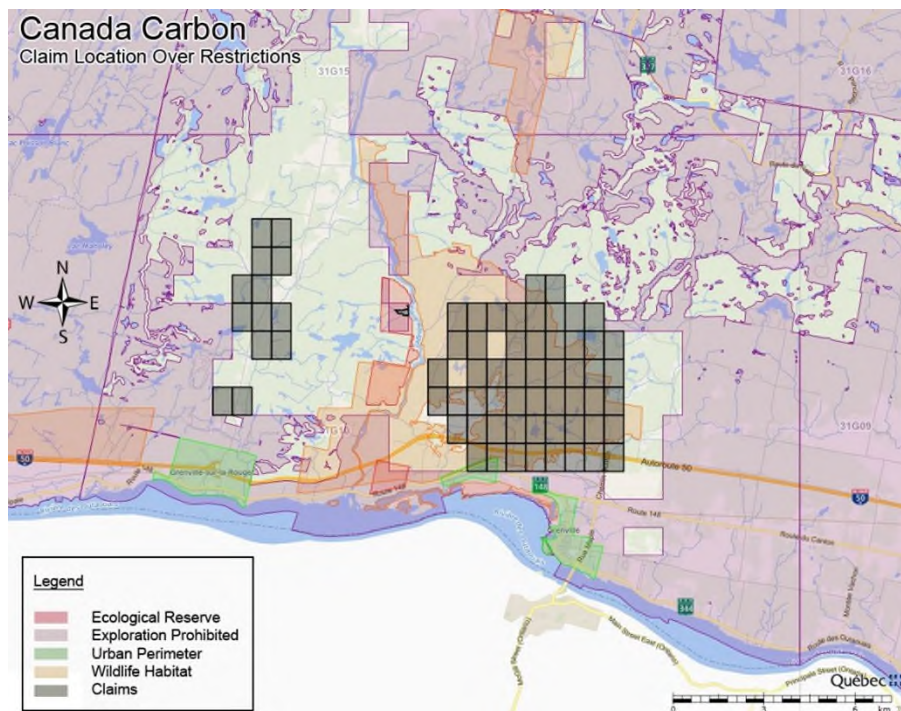

Figure 4-3: Restrictions Affecting the Miller Property

5 ACCESSIBILITY, CLIMATE, LOCAL RESOURCES, INFRASTRUCTURE AND PHYSIOGRAPHY

5.1 Access

5.1.1 Miller Property

The Property is well served by a public and private road network (Figure 4-2), owing to its proximity to Highway 50, Road 148, and the municipality of Grenville. The Property is accessible year-round by a network of maintained arterial and forest service roads, as well as unmaintained logging roads, skid trails, deactivated roads, and various other access roads. The Miller Property is accessible from Scotch Road connecting from Grenville town to McGillivray Lake, approximately 7 km away. From this public access, a private road leads westward for approximately half a kilometre and provides full access to the Miller project. During the winter season, vehicle access via the private road only requires a snow removal service, which is currently supplied by the land owner.

5.2 Climate

Southern Quebec is characterized by a continental climate (Figure 5-1 and Table 5-1). The land is usually free of snow from May to November. The summer lasts from June to September with average temperatures from 15°C to 20°C. Precipitation in the summer months averages 106 mm per month with extreme events capable of dumping 80 mm of rain in a day. The soil is normally frost free for 140 consecutive days after May 12 on average. As the autumn progresses, colder days are more frequent, and snow may start as early as late September. More commonly, snow only stays on the ground after mid-November. Autumn is quite variable with abrupt shifts from almost summery conditions to frost and back in 48 hours. Winter is cold with very short daylight and temperatures reaching as cold as -40°C, but averaging -7°C from December to end of March. Snow may come in storms with up to 50 cm snowfalls. The spring months (April to June) see an increase in temperatures coinciding with the thaw, with average temperatures from 6°C to 13°C.

5.3 Local Resources and Infrastructures

A wide range of local resources are available in the town of Grenville and in the nearby cities of Hawkesbury (Ontario) or Lachute, located respectively 10 km south and 20 km east of the Property. Specific activities such as tree cutting, excavating, drilling, blasting, as well as other main services (emergency services, equipment maintenance shops, transport companies, mobile electricians, mobile mechanics, security firms, IT firms, engineering, environmental and geological consultants, restaurants and hotel rooms) are available near the Property. Transportation and housing are available nearby and the local skilled labor force would be able to support a mining operation. A power line crosses the southern part of the Property and a railroad passes through the Ottawa Valley near Grenville.

The Uniroc Quarry, which owns excavation equipment and operates in a syenite rock body, is also located on Scotch Road. Uniroc produces ballast, abrasives, high performance rock, crushed rock and manufactured sand. Four other quarries are located in the vicinity of the Property. These quarries are operated using mobile equipment. Two additional limestone quarries are located on the Quebec and Ontario side of the Outaouais River. Canada Carbon has developed business partnerships with all of these quarries for equipment supply and expertise that were needed for the production of the bulk samples for its pilot plant program. Two of the quarries are owned by Foucault Excavation, a company with whom Canada Carbon has signed a contract to operate the proposed Miller Mine and part of the proposed marble quarry. Most of these quarries operate year round, and inclement weather does not stop their activities.

5.4 Physiography

The Property is characterized by rolling to steep topographic relief consisting of smooth-sided hills with altitudes ranging from 100 to 240 masl. It is primarily vegetated by leafy trees which mainly consist of maple, birch and aspen, with a few fir trees that have been partly cleared or selectively logged and replanted. Small swamps and peat lands are scattered all over the flat areas, whereas steeper hillsides and ridge tops display large rock outcrops. Valley areas are largely covered by extensive glacial or fluvial deposits up to 4 m thick. The drainage is dominated by the south-flowing Rouge River that runs west of the Property, and by the Calumet River that passes immediately north of the former Miller Mine. Some small lakes are found within and in the neighbourhood of the Property (e.g., Ogilvy Lake). Hillsides and ridges displaying ice flow indicators are observed throughout the Property and provide good evidence for south-east ice flow in the last glacial event.

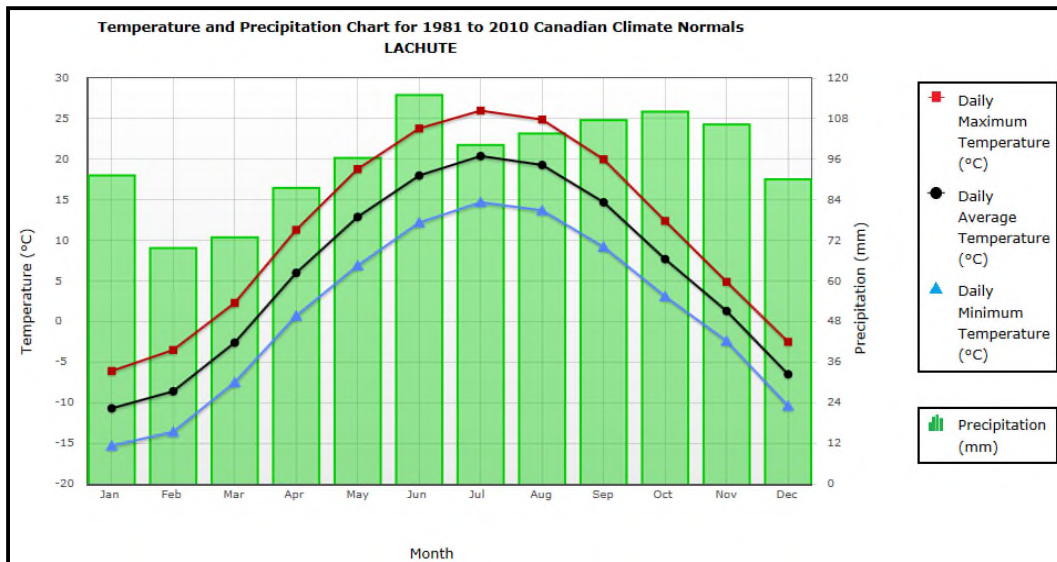

Source: http://climate.weather.gc.ca/climate_normals/ on January 15, 2016

Figure 5-1: Average Yearly Weather in the Project Area

Table 5-1: Summary of Lachute Weather Station Climate

	Jan	Feb	Mar	Apr	May	Jun	Jul	Aug	Sep	Oct	Nov	Dec	Year
Temperature													
Daily Average (°C)	-10.7	-8.6	-2.6	6.0	12.9	18.0	20.4	19.3	14.7	7.7	1.3	-6.5	6.0
Daily Maximum (°C)	-6.1	-3.5	2.3	11.3	18.8	23.8	26.0	24.9	20.0	12.4	4.9	-2.5	11.0
Daily Minimum (°C)	-15.4	-13.6	-7.5	0.7	6.9	12.2	14.7	13.7	9.2	3.1	-2.4	-10.4	0.9
Extreme Maximum (°C)	10.5	12.5	22.0	31.5	34.8	35.0	35.0	35.5	34.0	27.5	20.0	13.5	-
Extreme Minimum (°C)	-37.0	-35.0	-30.5	-15.0	-6.7	-1.5	3.5	0.0	-5.0	-8.9	-20.6	-34.5	-
Precipitation													
Rainfall (mm)	35.3	29.7	38.3	80.7	95.8	115.0	100.2	103.6	107.6	108.1	88.4	37.6	940.1
Snowfall (cm)	55.9	40.0	34.6	6.9	0.0	0.0	0.0	0.0	0.0	2.0	17.9	52.5	209.9
Precipitation (mm)	91.2	69.7	72.9	87.5	96.4	115.0	100.2	103.6	107.6	110.1	106.3	90.1	1150.5
Average Snow Depth (cm)	30.0	39.0	33.0	3.0	0.0	0.0	0.0	0.0	0.0	0.0	2.0	15.0	10.0
Extreme Daily Rainfall (mm)	56.9	51.1	38.4	38.1	49.8	62.2	68.0	56.0	81.8	69.4	57.0	34.6	-
Extreme Daily Snowfall (cm)	29.5	41.1	45.0	22.6	14.0	0.0	0.0	0.0	0.0	16.0	26.7	48.8	-
Extreme Daily Precipitation (mm)	62.2	51.1	45.0	40.0	49.8	62.2	68.0	56.0	81.8	69.4	57.0	48.8	-
Extreme Snow Depth (cm)	91.0	92.0	140.0	92.0	0.0	0.0	0.0	1.0	0.0	16.0	32.0	75.0	-



6 HISTORY

The graphite occurrence on Lot 10 of Range V of the Grenville Township was described by Sir William Logan in 1845-1846, and mining operations were subsequently initiated by R.V. Harwood of Vaudreuil (Ells 1904; Cirkel 1907). This initial period of exploitation may be the first graphite operation in Canada (Ells 1904; Spence 1920). Following a 25-year period of inactivity, the site was operated again for a short period of time around 1870 as the Miller Mine (Cirkel 1907) and was taken over in 1889 by Messrs. Rae & Co. without extensive work (Spence 1920). The most important episode of mining apparently occurred from 1899 to 1900, as reported in Obalski 1900:

Keystone Graphite Co.-This Company, composed of Americans, began last year to work on lot 10, range V of Grenville (county of Argenteuil) at a distance of 6 miles from Calumet station (C.P.R.). The deposit worked was formerly known under the name of the McVeity Mine. The graphite is found in a pretty pure state, in small veins or masses, in a crystalline rock. It is hand-picked on the spot and put in bags for shipment to the United States where it is treated and concentrated. The lots sent contain an average of 35 to 55 per cent of pure graphite and it is paid for according to the grade. Since the company has been working, about 25 carloads have been shipped; from 16 to 22 men have been employed throughout the year. The work consists of a cutting about thirty feet deep joining the main deposit where, it is stated, a thickness of 2½ feet of solid graphite has been found at times. The work is done by hand without the aid of machinery. The same company has done some other prospecting on a small scale.

Later in his report, Obalski reported that a total of 388 short tons of raw graphite were produced in 1900 in Quebec, while other graphite companies were almost inactive (Obalski 1900, p. 15-16); suggesting that an important part of this total production was derived from the Miller operations.

A database search for “McVeity” yielded several mentions of a prospector actively exploring for iron and mica in the late 1800s in the Ottawa region. One former phosphate mine near Gatineau (Quebec) also bears that same name and it is thus possible that an episode of activity at Miller took place under the name “McVeity”. It is also reported that graphite was mined in 1900 on adjacent Lot 9 of the same range by the National Graphite Co. (Ells 1904) and further south, near the Pacific railroad station by the Calumet Graphite Co. (Obasky 1900; Ells 1904).



Figure 6-1: Mineralization Found in the Historic Miller Mine Wall

The Miller Property was claimed by Glen Blair (independent prospector) in the late 1980s, who performed limited ground geophysics and found a new occurrence of graphite on the southwest corner of Lot 10 as well as some graphite boulders, about 100 m to the east (Blair 1988, 1989).

No previous work has ever been done on the Miller Property regarding quarrying marble for monument purposes or any other use.

6.1 2016 Preliminary Economic Assessment

In 2015, Canada Carbon Inc retained Tetra Tech to prepare a Preliminary Economic Assessment (PEA) for the Miller Project, titled “Technical Report and Preliminary Economic Assessment for the Miller Graphite and Marble Property, Grenville Township, Quebec, Canada”, with an effective date of March 4, 2016. The Mineral Resources estimates reported therein were conducted by SGS Canada Inc the CIM Definition Standards for Mineral Resources in accordance with NI 43-101 Standards of Disclosure for Mineral Projects, whereas the optimized pit shell and cut-off grade estimation were conducted by Tetra-Tech.

The Mineral Resource estimates from 2016 totalled 952,000 t of Inferred graphite at an average grade of 2.00% Cg from within two graphite pit shells at a cut-off grade of 0.50% Cg, and 1,180,000 t of Inferred graphite at an average grade of 0.53% Cg from within the marble pit, using a cut off grade of 0.40% Cg. There was also estimated to be an Inferred resource of 1,519,000 t of ornamental marble.

Five flotation metallurgical test programs were conducted on samples from the Miller Deposit with head grade from 0.53% graphitic carbon to 61.2% graphitic carbon from 4 laboratory scale evaluation and one pilot plan processing approximately 127 t from a bulk sample. These programs produced graphite concentrates that consistently exceeded combined concentrate grades of 95% total carbon or higher. The flotation concentrate samples responded well to both hydrometallurgical and thermal purification processing methods, with the best results from thermal treatment. By means of commercially available thermal treatment, graphite concentrate produced from the pilot plan trial can be directly upgraded to high-purity specialty graphite containing 99.9998% graphitic carbon.

Tetra Tech prepared an open pit mining study for the project based on an annual target production of 1500 t of refined graphite. The PEA proposed 19 years life-of-mine (LOM) for graphite recovery, including 1 year of preproduction, 11 years of active mining operations and 7 years of stockpile re-handling. The graphite pit will be mined using conventional truck/loader open pit mining. The proposed graphite concentration plant will process the Miller graphite mineralization using conventional froth flotation as proposed by SGS Canada in Lakefield, Ontario. The final concentrate will be bagged and shipped to Asbury site for further purification treatment.

The Miller site will consist of open pit and equipment, a mill, a processing complex and water treatment plant. Electrical power will be supplied from grid power available along the main municipal road. The Asbury site will consist of a thermal upgrading facility, a water treatment plant and a final graphite production stage.

Environmental baseline studies were conducted in 2015 and 2016 on both sites and the various permitting processes are ongoing. Characterisations of soils, vegetation, water, wildlife were conducted, and mining operations will have limited impact on the project site. Risk avoidance, mitigation and compensation measures will be evaluated, developed and implemented to minimize impacts from project development and operations on the environmental and social conditions at the Miller and Asbury sites. Complete monitoring will be done on each at each stage and will be used to develop suitable environmental management and closure plans.

Mine development and operations are expected to have a positive effect on local employment and the economy. Supplies and labour are expected to be sourced from southern Quebec with a priority to local citizens. Combined mine and treatment site operations should require an estimated 100 person workforce.

Capital expenditure is estimated around \$44.4 million (CAD) with a total LOM average operating cost for purified graphite at \$8,300/t (CAD). Mine closure and rehabilitation costs are estimated at \$1 million, primarily for the rehabilitation of the tailing disposal area and the sedimentation pond. There will be no waste rock left to manage on site at the time of closure.

Tetra Tech prepared an economic evaluation of the Project based on a pre-tax financial model and the following pre-tax financial results were calculated:

- 100.2% internal rate of return (IRR)
- 1.9-year payback on \$44.4 million initial capital cost
- \$149.7 million NPV at an 8% discount rate

Analyses were conducted to evaluate the sensitivity of the Project's merits (NPV, IRR and payback periods) to the following key variables: graphite price, exchange rate, capital cost and operating cost.

Following the drilling and exploration work conducted in 2016, the geological model of the mineralization has changed significantly from the model presented in the PEA. It has been decided to present this report as a resource estimate, and to proceed with a Feasibility Study in the near future, which will better identify economic opportunities and further assess the Project's viability.

7 GEOLOGICAL SETTING AND MINERALIZATION

7.1 Regional Geology

The Project area lies in the same locality where observations by Sir William Logan (1863) led to the recognition of the “Grenville Series”, which was later extended and redefined as a geological province.

The Grenville Province is recognized as a deeply exhumed Mesoproterozoic Himalayan-type collision orogenic belt that extends over thousands of kilometres and is interpreted as a collage of gneissic terranes that were subjected to high-grade metamorphism (Martignole and Friedman 1998; Corriveau and van Breemen 2000; Corriveau et al. 2007). High-grade metamorphic terrane stacking occurred along deep-level ductile shear zones and resulted in the main crustal build-up.

The Project area is included in the south portion of the Morin Terrane (Figure 7-1), composed of supracrustal rocks, commonly at granulite metamorphic facies, and intruded by several bodies of granitic to anorthositic composition (1.14 Ga). The intrusive suite is grouped into the Morin Anorthosite-Mangerite-Charnockite-Granite (AMCG) Suite (Corriveau et al 1998), as depicted in Figure 7-1. To the west, the Morin Terrane is bounded by the Central Metasedimentary Belt along the Labelle deformation zone, which runs more or less north-south (Martignole et al. 2000). The Morin Terrane is bounded to the south along a major normal fault by the St Lawrence Lowlands, which constitutes a younger (early Paleozoic to the end of the Ordovician) geological province.

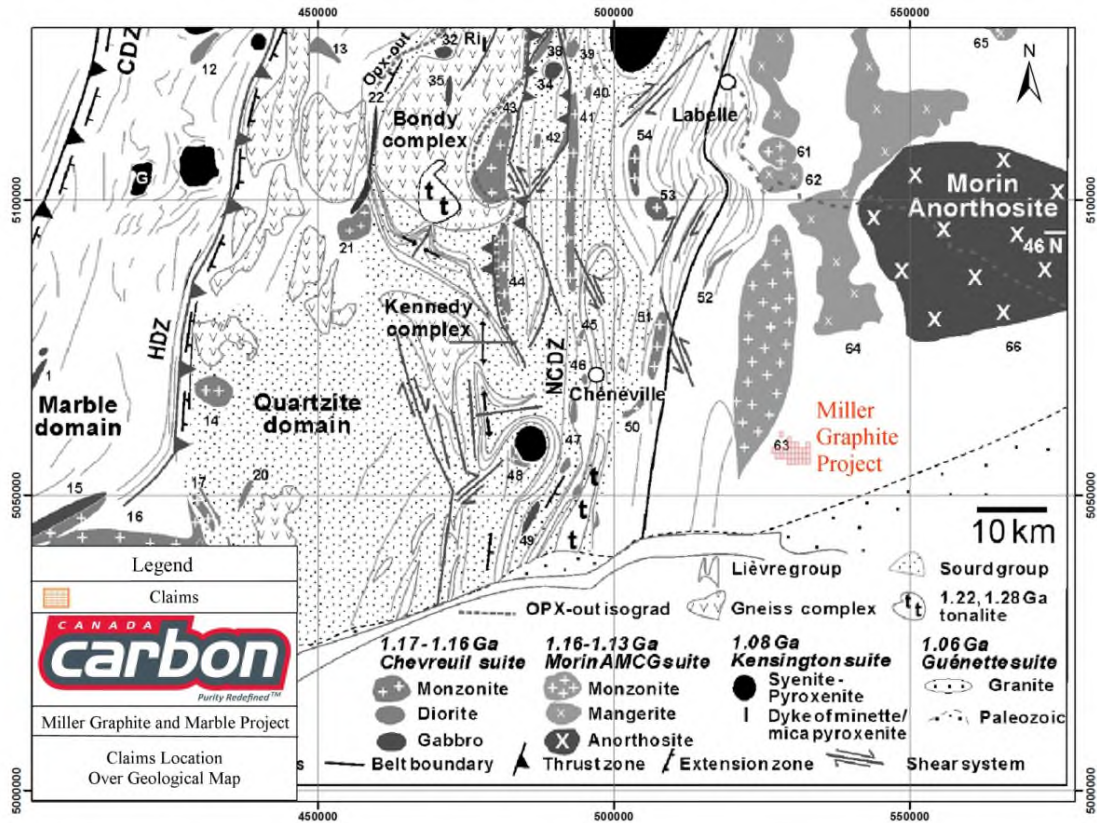

Figure 7-1: Regional Geological Map

7.2 Local Geology

The southern portion of the Grenville Township was mapped by Philpotts (1961) who detailed the folded sequence of quartzo-feldspathic gneiss, quartzite and crystalline limestone (marble); this sequence is characteristic of the Grenville Series from Logan (1863).

The well-banded quartzo-feldspathic gneisses were divided into two groups on the basis of whether they contain biotite or pyroxene, which rarely occur together in the area. Philpotts determined that gneisses are not the dominant lithology, occurring as remnants between the various intrusives of the Morin Series, which includes gabbro, monzonite, mangerite, granite and syenite. Quartzites were documented as very massive, well jointed, white or pinkish rocks. Crystalline limestone appeared to correspond to two large beds (Figure 7-2).

Microscope examination of the marble unit revealed twinned calcite, sphene, zircon, diopside, serpentine (after olivine), graphite, quartz, microcline and grossularite. Wollastonite was only noted near igneous contacts. Various pegmatite units were observed and seem to be affected by scapolite alteration of feldspar where they intrude crystalline limestone. Finally, Philpotts also noted younger diabase and lamprophyre dykes cutting through all units.

Graphite is observed as dissemination and pods/veins in the marble, skarn and paragneiss units of the property (Figure 7-2), several pods and veins have been identified and explored by Canada Carbon and are named with the VN prefix (Figure 7-2). Each of these showings are described in greater details in Section 9.2 of this report.

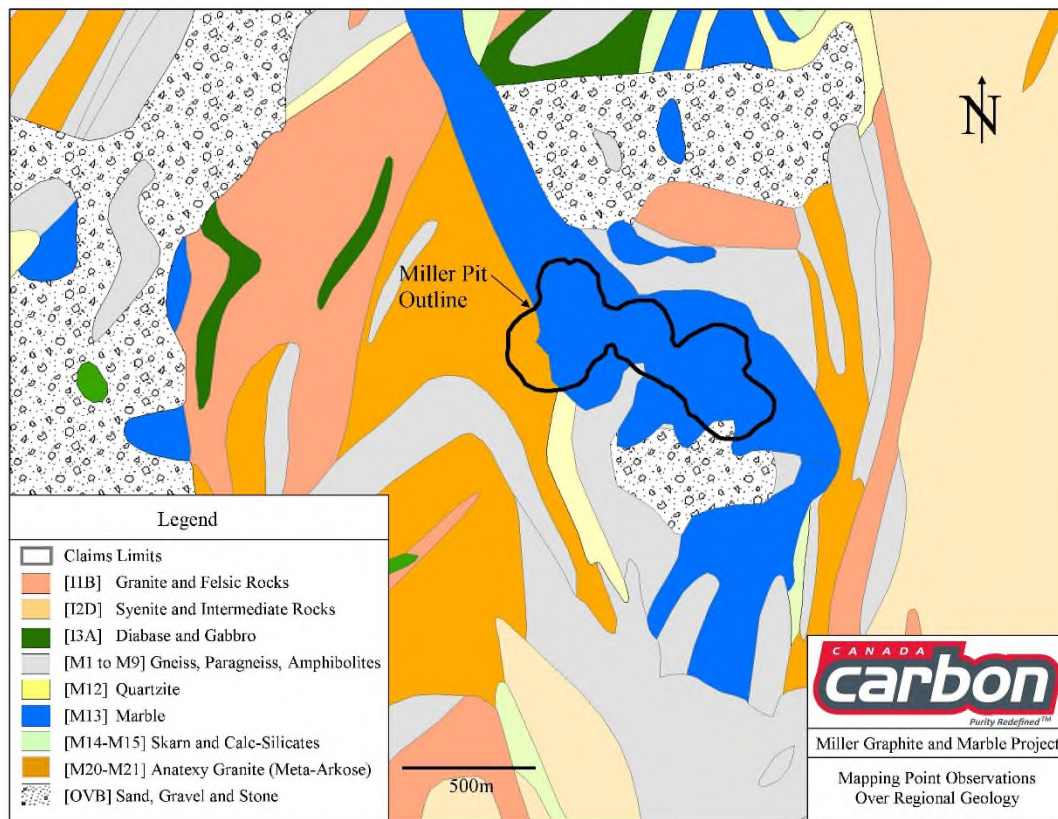

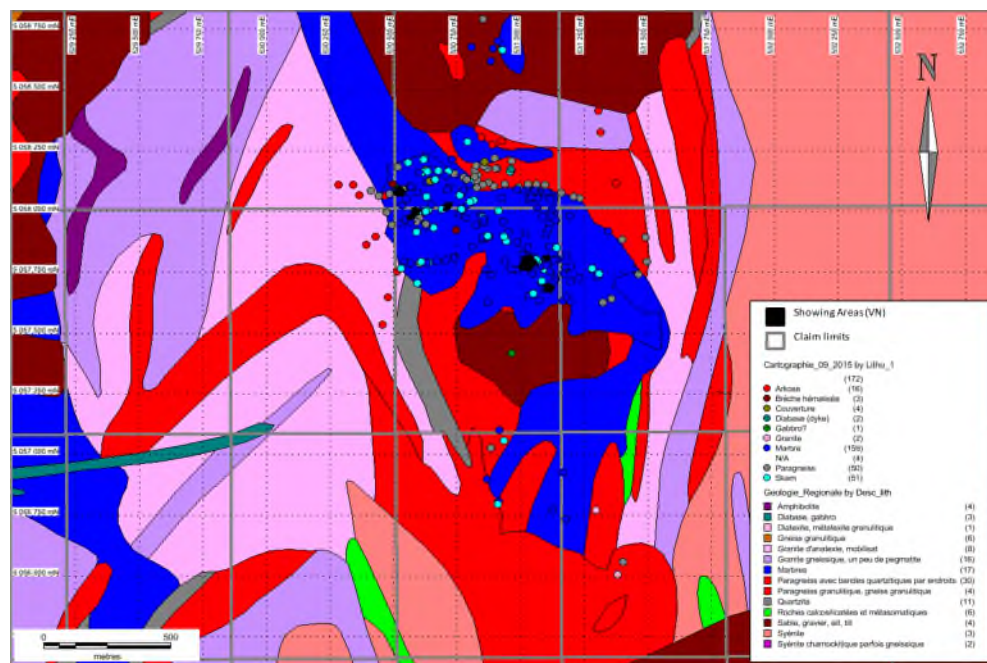
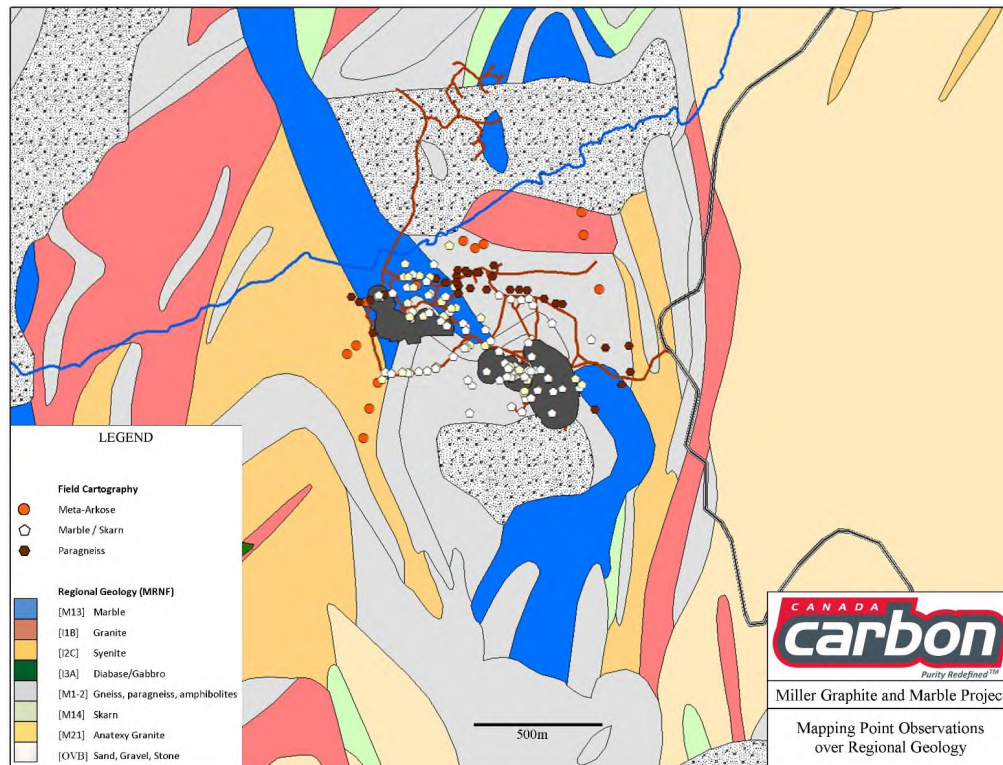

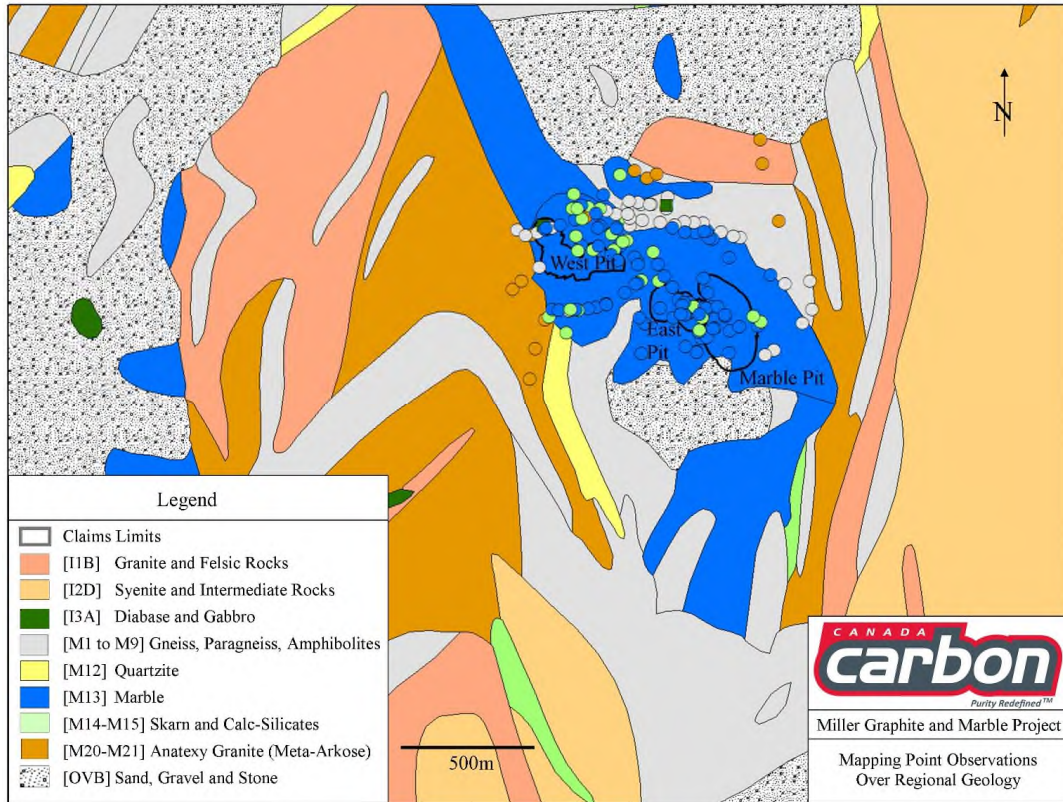

Figure 7-2: Regional Geology Map over the Project Area with Mapping Point Observations

7.2.1 Marbles

The protolith of the marbles are interpreted to be sandy limestones, with variable amounts of organic matter (which might be the origins of graphite and sulfides observed on the Property). Canada Carbon’s interpretation is that the limestone might have reacted with quartz grains within the unit during metamorphism to form marble and calc-silicate dominated rocks. The presence of sand in the marble might have allowed the following reaction: $CaCO_3 + SiO_2 = CaSiO_2 + CO_2$. Presence of contaminants (clay) within the limestone unit could have provided lead, magnesium, sodium, aluminum, and other elements.

The white marbles are medium to coarse grained (1 to 10 mm) and are white to silver-grey (Figure 7-3). Surface alteration has affected the marble for a depth of a few centimeters to half meter, creating a yellowish color and friable layer, which turns easily into sand. Disseminated coarse graphite (about 0.5% in abundance and 1 to 5 mm in size) is present in most of the marble unit. Accessory minerals include apatite (blue or green), chondrodite and diopside (Figure 7-3).

Enclaves are sometime present in the marble (referred to as "dead snakes"; Figure 7-3). They were interpreted by Canada Carbon's as skarn layers (quartz-rich horizon or pods in the marble that reacted to create calc-silicates dominated rocks) or skarn shear-zones (units created by the reaction between the marble and fluids brought by shear zones) that were folded and twisted by subsequent convection. The dead snakes are often seen near skarn horizons and they have a similar mineralogical and geochemical composition. Enclaves often contain sulfide and graphite, reaching up to 5% graphitic carbon and/or sulfur. The dead snakes range in size from 5 to 25 cm, yet they can reach up to 10 m in length. However, the dead snakes could also represent deformed, partially melted interbeds of detrital rocks (sandstone and clay rich sedimentary rocks) in the initial carbonate sequence (Figure 7-3), typical of a marine to continental shelf environment. These interbeds are better preserved at the Property (Figure 7-3).

Silicified marbles are also observed and are fine to medium grained (1 to 5 mm), with a white to yellowish color. Slight to intensive silicification of the rock is present. Silicified marbles present a very gradual alteration (rarely sharp contacts). This unit contains little to no graphite or sulfides and is much harder than regular marble units.

7.2.2 Skarns

Skarns represent the main alteration product of the marble unit. Possible small-scale zoning has been identified, but no large-scale zoning was observed so far. Light chlorite-epidote alteration areas are also observed within the skarn units. The skarn units present many variations in texture, varying in size, content and spatial relationships with other lithologies (Figure 7-3).

Coarse skarns comprise 1 to 25 cm or larger grains. They are primarily composed of quartz and feldspar, with frequent wollastonite pods (5 to 15 cm), pyroxene (up to 25 cm), titanite (up to 5 cm), zircon (1 to 100 mm) and chondrodite. The coarse skarns form long, thin zones (meter-long, 10 cm in width) inside white fine skarn units. No sulfides are observed in this unit. Grey skarns are fine grained (less than 3 mm) and form salt-and-pepper looking rocks. They contain quartz, feldspar and pyroxene with little to no accessory minerals (titanite, zircon). Sulfides are often present (less than 1%) in this unit. Green skarns are fine to medium grained (1 to 5 mm). More than 50% of the mineral content of this rock unit is composed of pyroxene (anhedral diopside), with small amounts of quartz, feldspar and sulfides. The interpreted protolith might have contained the exact amount of limestone and sand to create a complete reaction and modification of the unit to massive diopside. Pink skarns are fine grained (less than 1 mm) and mainly comprise pink feldspar and quartz. They are often present in banded graphite formations.

7.2.3 Paragneiss

The phlogopite paragneiss comprises significant amounts of phlogopite that can reach up to 15 cm or more in size. The phlogopite paragneiss has been historically exploited for micas. The paragneiss

itself is fine grained (1 to 2 mm) with variable amounts of feldspar, quartz and other mafic minerals (pyroxene, amphiboles, biotite, etc). The paragneiss ranges from dark brown to black in color (Figure 7-3). The protolith is interpreted to be composed of metamorphosed claystone and siltstone deposited in a shallow environment. White paragneiss is a quartz-feldspar rich gneiss, often partially melted, extruding large quartz-rich veins. The quasi absence of mafic minerals results in a white-to-grey colored gneiss.

7.2.4 Meta-arkose

Meta-arkose units are composed of red-orange rocks that seem to be composed of fused grains of sand (Figure 7-3). Magnetite crystals are locally observed within the meta-arkose. Pegmatite veins formed by partial fusion of this unit are observed. The protolith is interpreted to be sandstone comprising quartz and potassic feldspar (hence the meta-arkose name).

7.2.5 Dykes

Large lamprophyre dykes (20 to 150 cm) are observed on the Property, oriented northwest-southeast and sometime with east-west offshoots. The dykes often cut through the mineralization and other lithologies. The dykes are sometimes kinked and/or foliated.

Coarse diabase dykes appear to be composed of large feldspar crystals in an aphanitic mafic matrix (Figure 7-3). Sulphides are locally present in filled fractures. Fine diabase dykes are dark-green to green, composed of a mafic aphanitic matrix. Quartz-filled vacuoles are sometime observed near the center of the dykes. Sulfides are sometimes present as fracture filling material. Yellow diabase dykes form khaki to yellow-green aphanitic units. Evidence of numerous intrusive pulses are observed; including layers of different colors near the borders. Sulphides have never been observed in the yellow dykes.

7.2.6 Breccia

Hematized breccias have been found near the Du Calumet River. The breccias are mostly composed of iron-manganese carbonates, with the presence of large pyrites and fluorine crystals (Figure 7-3).

7.2.7 Pegmatite

Conventional pegmatites are rarely observed in the Project area. The only pegmatites might have been observed at VN7 and from 10 to 50 cm wide by 0.5 to 5 m long intrusive bodies (Figure 7-3). The origin of these bodies is interpreted to be local fusion of rocks, producing large pinkish feldspar, in a quartz-feldspar matrix. Zoned vesuvianite has been identified and confirmed by geochemical analysis. The pegmatites are heavily folded and dismembered.

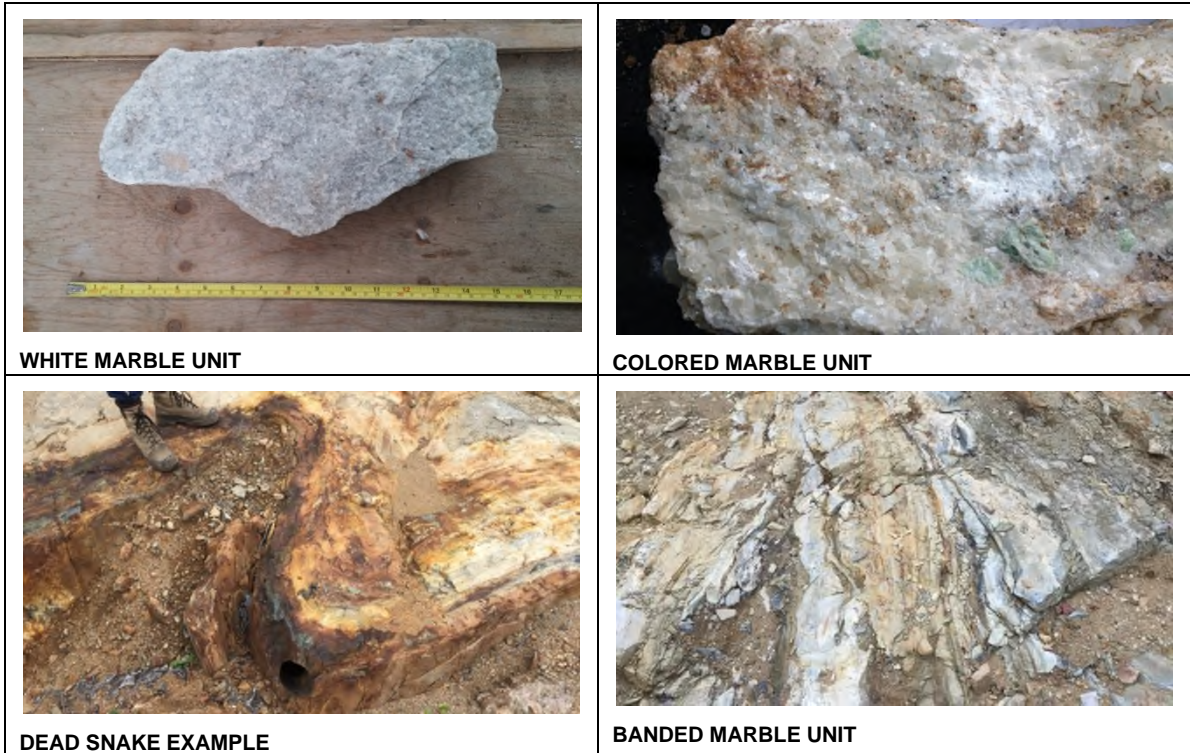



Figure 7-3: Typical Rock Units Found on the Property

7.3 Mineralization

Graphite has been found as disseminations in marble, in sulphide-bearing paragneiss, in pods and veins on the Property. In known occurrences, graphite can be alone or in association with other minerals, including pyroxene, scapolite, titanite, zircon and wollastonite (Spence 1920). Through trenching, Canada Carbon has identified many examples of graphite mineralization associated with marble and detrital rock sequences. Numerous variations of the graphite mineralization are observed within the Project area. Graphite primarily occurs in well crystallized euhedral flakes.

7.3.1 Graphite Mineralization

7.3.1.1 Wollastonite Pods

Wollastonite-graphite mineralization is a frequent association on the Property. This mineralization form often appears in small pods of tens of centimeters in diameter and can reach up to 1.6 m in thickness at the VN1 showing. Both wollastonite and graphite form well crystallized minerals (Figure 7-3) and graphite assays around 15% in these pods. On the VN2 showing, wollastonite appears as a nucleus around which the graphite appears to accumulate.

7.3.1.2 Banded Graphite Formation

Banded graphite formations are thin (1 to 5 mm) bands of graphite sandwiched between thin (1 to 10 mm) layers of graphite-quartz-feldspar, stacked closely, and reaching thicknesses of many metres (Figure 7-4). The grain sizes of this mineralization type are small (less than or equal to 1 mm). The banded formations are continuous over long distances (10 m and longer) and affected by intense folding. The average graphite content of this unit is between 5 and 10%.

7.3.1.3 Graphite Pods (Marble)

Small pods (tens of centimetres long to a couple of centimetres wide) of pure graphite are often present in the white marble units (Figure 7-4). Pods of metric scales are also present on the VN2 and VN3 showings. The graphite grains are coarse (5 to 50 mm) and form euhedral flakes. Many of the pods are observed along an east-west alignment direction.

7.3.1.4 Disseminated Graphite (Marble)

In all the marble units observed, graphite occurs frequently in well crystallized, euhedral, small (1 to 5 mm) disseminated crystals (Figure 7-4). The chemical reaction between carbonate and silica might have produced calc-silicates and graphite, which seems to precipitate at the boundary of the calc-silicate and marble grains. The average graphite content in the marble is approximately 0.5% graphite.

7.3.1.5 Disseminated Graphite (Skarn)

Similar to disseminated graphite in marble, disseminated graphite in skarn occurs almost everywhere, more frequently close to marble units (Figure 7-4). In skarn units farther from marble units, sulfides are more abundant. Graphite in skarn units is often found in clumps instead of flakes and is far less homogenously distributed than in the marble units.

7.3.1.6 Graphite Veins

Graphite veins seem to follow shear or fault zones, which might be evidence of structural control of metamorphic hydrothermal fluids (Figure 7-4). They are thin, centimeter-wide, sheets of aphanitic graphite that can cover many square metres. Directions of movement of faults are registered in the graphite veins as strikes and kinks. No general directions have been observed, as they are often following folded structures.



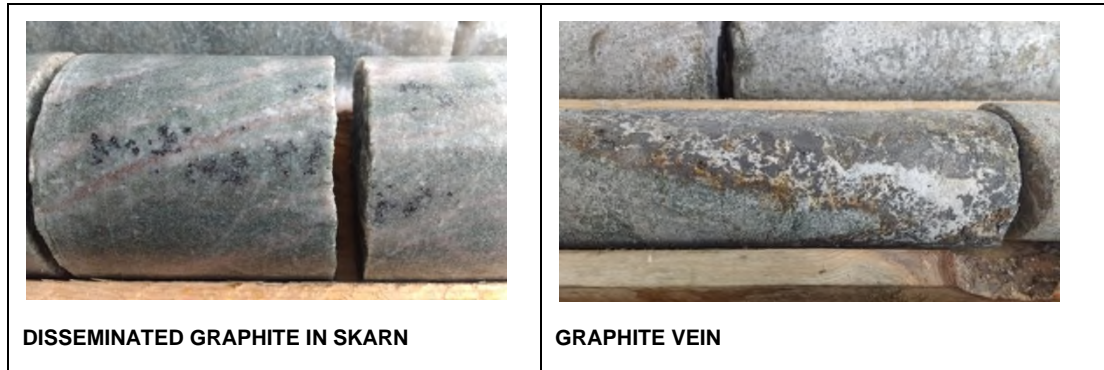

Figure 7-4: Typical Types of Mineralization Found on the Property

7.3.2 Marble

The medium to coarse grained white marbles on the Property has demonstrated its visual quality for architectural stone (Figure 7-5). The suitable white color marbles are overlain by a 1 to 4 m-thick surface alteration that creates a yellowish color and friable layer, which is unsuitable for production. Disseminated graphite (less than 0.5% in abundance) and other accessory minerals include apatite (blue or green), chodrodite and diopside, which give an interesting color for the architectural stone market.



Figure 7-5: Typical White Marble Found on the Property

8 DEPOSIT TYPE

8.1 Graphite

Canada Carbon is actively exploring for metamorphic-hosted vein-type and disseminated graphite deposits, long known to occur in the Outaouais region of southern Quebec (Cirkel 1907; Simandl and Kenan 1997). Other typical examples, mostly in granulite terrains, are found in Sri-Lanka (Weis et al. 1981, Glassley 1982, Katz87), south India (Radhika et al. 1995, Baiju et al. 2005) and Spain (Rodas et al. 2000), among others.

Generally, graphite occurrences can be grouped into two categories: 1) syngenetic, which are derived from carbonaceous matter in host rocks and 2) epigenetic, which originates from precipitation of solid carbon derived from carbonic content in fluids (mainly carbon dioxide and methane). The latter form of deposit is less common in nature, but represents the more interesting of the two from an economical perspective (Rodas et al. 2000).

The Project represents an example of a granulite-hosted, high temperature graphite deposit, which could be paralleled to the Sierra de Aracena metamorphic belt described by Rodas et al. (2000), where the same type of graphite occurrences are found: I) stratiform graphite associated with gneiss and quartzite interbedded with calc-silicate series; II) disseminated graphite; III) graphite associated with anatectic tonalities and their restitic enclaves and IV) graphite veins. Graphite in all types of occurrences shows high crystallinity as revealed by the x-ray diffraction (XRD) study and thermal properties (Rodas et al. 2000).

Within the Outaouais region of Quebec (Tremblay and Cummings 1987), and particularly at the Miller deposit (Ells 1904, Spence 1920), the mineralogical association of graphite and calc-silicate rocks suggests a proximal source of carbon-rich fluids generated by silicification of nearby carbonate-rich rocks. Many studies have recognized that metasomatism, or more specifically skarnification, is efficient at producing carbon-rich fluids through the following reaction (Rodas et al. 2000; Pope 2004):

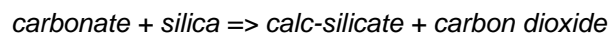

The geological sequences at the Miller deposit and the geological setting also suggest the presence of a continental margin type environment, which has been affected by high-grade metamorphism. Detritic sedimentary sequences; comprising meta-arkoses and gneiss rocks are interbedded with marble sequences, presenting restites; deformed and dismembered enclaves.

8.1.1 Disseminated Graphite

Disseminated graphite in carbonate sequences (marble) could be explained by both syngenetic and possible epigenetic processes. The presence of small amounts of organic matter in the marble protolith

could explain the formation of disseminated graphite in this sequence. However, local skarnification and metasomatic reactions could have produced carbon-rich fluids which percolated through the marble, hence depositing graphite in the grain interstices.

8.1.2 Banded Graphite

Graphite is also observed as banded flakes within gneiss sequences, which have resulted from the metamorphic transformation of organic matter within detritic sequences composed of limestones, sandstones and clay sediments rich in organic matter, within a carbonate sequence.

8.1.3 Graphite Pods Associated with Restites

Some graphite pods are observed in close association with paragneiss enclaves within a carbonate sequence. The anatectic paragneiss shows typical igneous textures and include quartz, alkaline feldspar, plagioclase, biotite, sillimanite, cordierite and a variety of accessory minerals, such as muscovite, zircon, apatite and rutile. The graphite deposition is interpreted to be associated with organic matter rich clay sediments interbedded with limestone. High-grade metamorphism caused partial melting of the rock sequences and partial remobilization of the organic matter to graphite pods.

8.1.4 Vein-type Graphite

Graphite vein deposits are interpreted to have originated from the remobilization of carbon as carbon dioxide and methane in metamorphic fluids at the base of the crust or deeper within the mantle (Glassley 1982, Katz 1987, Skippen and Marshall 1991, Simandl and Kenan 1997). The fluids are channelled upward along major fractures where deposition as graphite is triggered by chemical changes in the fluids in response to cooling and dewatering (Luque et al. 2013). Fluid transport and graphite deposition imply that structures played a major role in the location and shape of the resulting deposit. The precipitation of carbon in veins takes place at high temperatures, from 700 to 800°C, which favor the formation of large and well crystallized graphite flakes. Graphite veins are characterized by coarse flakes with a high degree of crystallinity, which is suitable for new technological applications (Luque et al. 2013).

8.2 Marble Architectural Stone

The transformation of limestone to marble by high-grade metamorphism results in a crystalline calcite dominated rock with variable amounts of accessory minerals, depending on the quantity of heterogeneities in the protolith.

Marbles offer different colors and texture with variable amounts of veining and fractures. In the case of the Miller Property, the marble sought by potential buyers is white in color with as few fractures as possible.

9 EXPLORATION

Since the acquisition of the Miller Property in 2013, Canada Carbon has discovered multiple new graphite mineralized showings, including nine high-grade surface graphite showings, and large, lower-grade disseminations of graphite in marble and skarn units. Induced polarization (IP) surveys indicate that multiple anomalies are located along the trends of the current area subject to exploration, most of which were drilled in 2014 and 2015. The geophysical anomalies are open on strike at both extremities and regional airborne geophysics revealed additional targets elsewhere on the Miller Property.

9.1 Initial Prospecting Work

After acquiring the Miller Property in February 2013, Canada Carbon hired SL Exploration Inc. to perform prospecting work. The objective was to locate the old mine site and proceed with an initial assessment of the Miller Property's accessibility and the historical mineralization. The field crew located the mine site approximately 150 m north of the position reported in the MERN database. Field observations in the old mine pit revealed that graphite veins occur in a marble unit near skarn and paragneiss rocks. The larger graphite veins appear to have been at least partially mined in the past and their orientation corresponds to the mine pit's north-south orientation.

Canada Carbon carried out initial prospecting in 2013 to verify historical data and a later prospecting phase to verify ground (MaxMin, very-low frequency (VLF), IP, ground time-domain electromagnetics (TDEM)) and airborne (TDEM) geophysical anomalies. The geophysical surveys were performed by different geophysics companies. Following the prospecting phase on the known anomalies, Canada Carbon proceeded to trench the ground anomalies and test some of them by performing drilling campaigns. Trenching and drilling on a coincident IP – IMAGEM anomaly (in 2013) detected two graphite veins (named VN1 and VN2) along a contact zone. The main focus of Canada Carbon's exploration work then became the investigation of these showings and the contact zone.

The objective of the follow-up prospecting work in March and April 2013 was to obtain samples from the graphite veins for metallurgical testing (Section 13.0) and to better characterize the grade of the vein material. The melted snow cover allowed additional geological mapping in the mine pit and structural measurements were also taken. Veins exposed in the east part of the mine pit were sampled.

9.2 Geophysics

9.2.1 Ground Electromagnetic (2013)

Géosig Inc. of Quebec City was contracted to perform a ground electromagnetic (EM) survey to test the immediate area of the historical mine pit using various methods, including Max-Min, IMAGEM, IP and Beep Mat. The objective of this work phase was to test the ability of the different methods to detect graphite veins (Simoneau and Boivin 2013). The methods were locally tested over a 500 by 400 m grid consisting of eleven east-west lines spaced 50 m apart, centered over the Miller pit. The various surveys were carried out during the last two weeks of May 2013 by various teams of two to three people including experienced geophysicists, one of which was the creator of the IMAGEM detector.

This initial orientation study revealed several small anomalies, most of them overlapping two or more of the applied EM methods. The IMAGEM method detected near-surface anomalies that were followed-up by Beep Mat surveys, allowing individual graphite veins to be pinpointed and exposed after removing the thin cover of glacial till. The most significant results from this initial EM survey is a series of anomalies located about 200 m west of the pit where subsequent mechanical trenching revealed new graphite occurrences (VN-1 and VN-2), as detailed in Section 9.4.1.

9.2.2 Airborne Versatile Time-domain Electromagnetic Survey (2013)

In the spring of 2013, Canada Carbon commissioned Geotech Ltd. of Aurora, Ontario to complete a helicopter-borne versatile time-domain electromagnetic survey (VTEM Plus) and a Horizontal Magnetic Gradiometer (HGrad) geophysical survey over the two claim blocks of the Miller Property. The survey was flown on June 13, 2013 over an area of 25 km², yielding a total of 336 line-km of geophysical data. Positioning was provided by a global positioning system (GPS) navigation and radar altimeter. The survey lines were oriented northeast-southwest and generally spaced 100 m apart, with a tighter spacing of 50 m in the central part of the East Block over the areas of historical mining and recent graphite discoveries. The survey lines were flown with an AStar 350 B3 helicopter at an elevation of 91 m above ground at an average speed of 80 km per hour, producing an average terrain clearance of 60 m for the EM bird and a magnetic sensor clearance of 67 m.

Following the interpretation work, Geotech identified six conductors (three on the East Block and three on the West Block) based mainly on the Tau decay parameter evaluated from time domain EM data and vertical magnetic gradient contours (Figure 9-1 and Canada Carbon press releases of September 12 and October 8, 2013). All anomalies were later subjected to detailed modelling to determine the orientation and depth of the associated conductors (see Canada Carbon press release of November 14, 2013).

The East Block contains three major anomalies, E1 to E3. Anomaly E1 is located 800 m north of the mine pit, with an approximate diameter of 400 m; E2 is 280 m southeast of the mine pit and 150 m

south of Trench #3; E3 is located 545 m southeast of the Miller pit (Figure 9-1). Anomalies E1 and E3 and the north part of E2 are on land covered by Canada Carbon’s access agreement for exploration work. Based on the modelling work, anomalies E1 and E2 occur at depths of 100 m and 80 to 100 m, respectively. Anomalies E1 and E2 occur in marble units that are known to contain graphite elsewhere on the Miller Property. Magnetic maps show that E1 is located at the contact of two magnetic anomalies which may correspond to the contact between two geological units, suggesting a potentially similar context to that of the Miller mineralization.

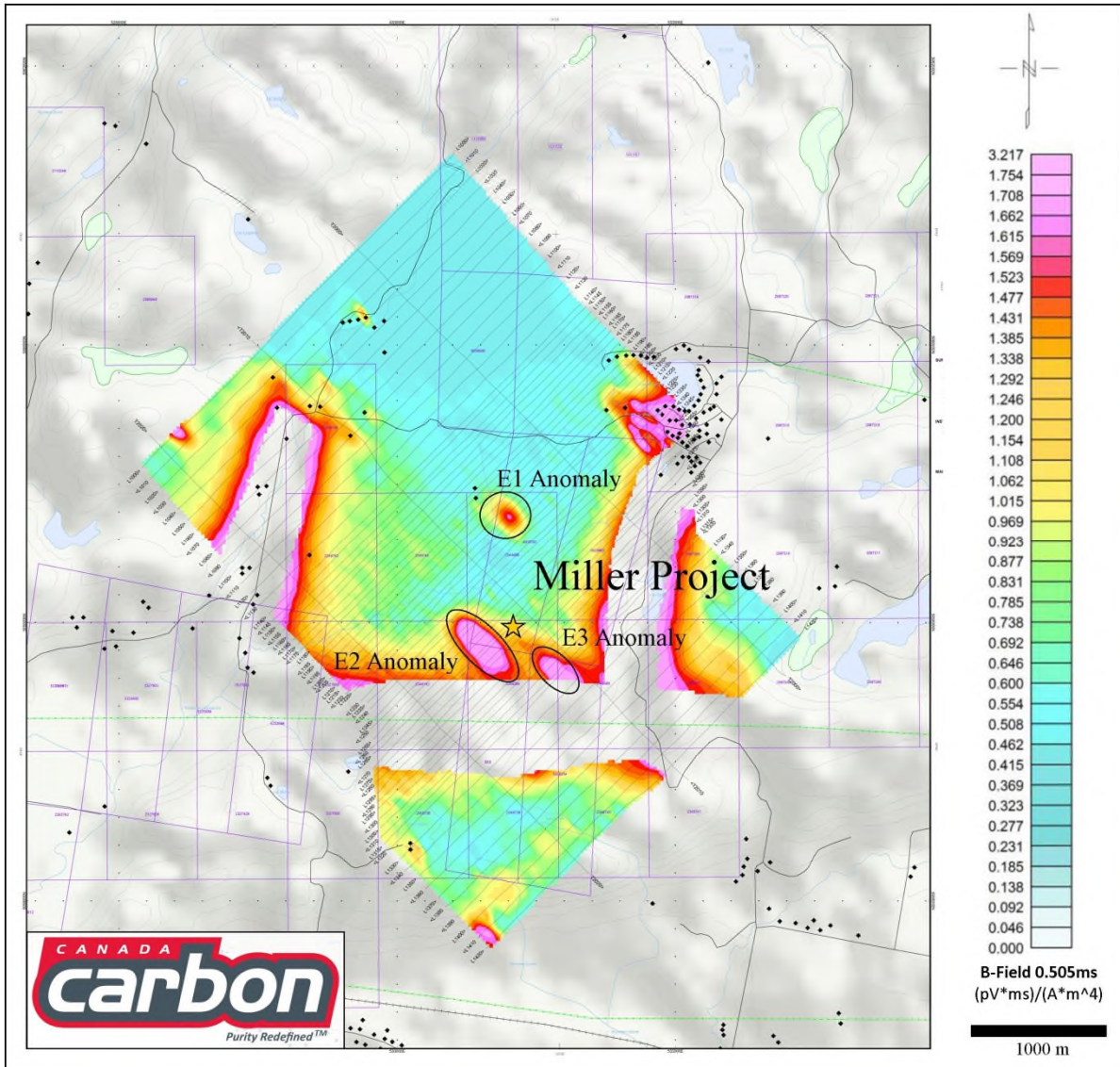

Figure 9-1: Miller Property Airborne TDEM Anomaly Map

9.2.3 IMAGEM Survey (2013)

In September 2013, Géosig was contracted to perform a second IMAGEM survey in the vicinity of Trench #3. The detailed mobile TDEM geophysical survey was completed from September 18 to 22, 2013, to investigate in greater detail the previously identified EM anomalies associated with graphite occurrences. The survey operators could not follow the grid lines due to the presence of the trench, and instead followed a meandering path that was precisely recorded by a GPS unit integrated with the IMAGEM detector. This provided complete coverage of the planned area (300 by 150 m) with an irregular spacing of 50 to 200 m. This method increased the density of readings near positive responses, resulting in a better definition of the anomalies. A total of 9.55 line-km were completed with an average spacing of 20 readings per metre. The survey was successful in delineating well-defined anomalies over the known graphite occurrence and revealed new anomalies that required further investigation (Figure 9-2). Although under development, the IMAGEM method appears very promising for the detection of near-surface conductors and seems particularly efficient for graphite vein mineralization.

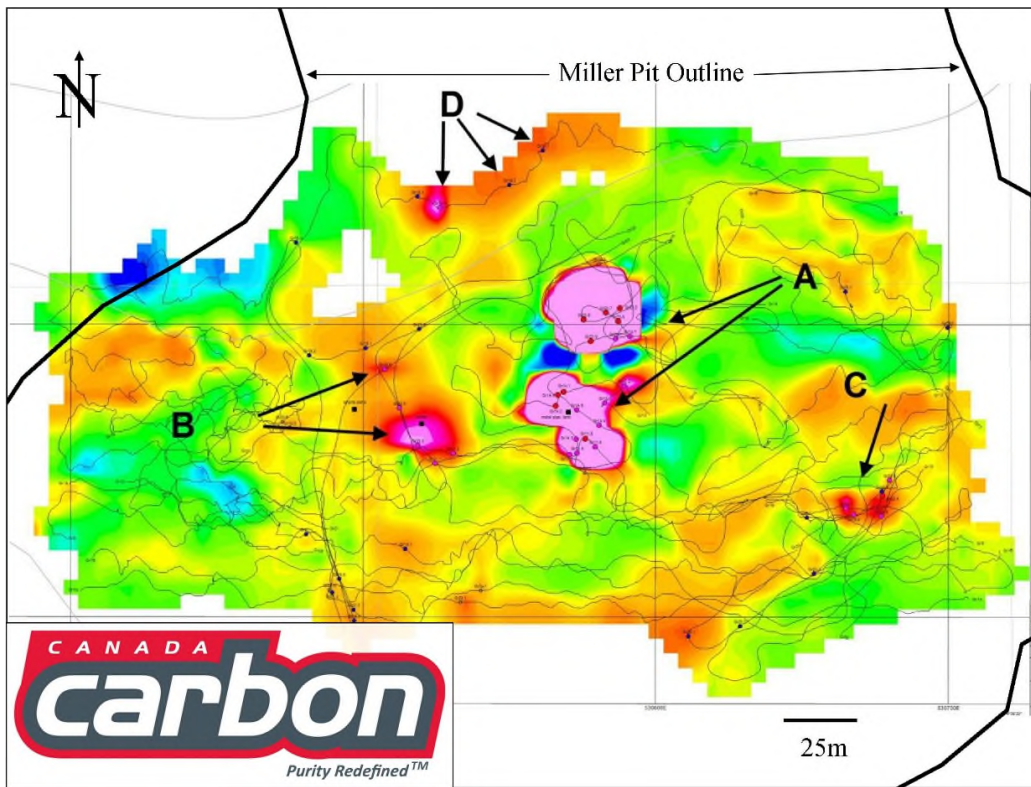

Figure 9-2: IMAGEM Anomalies Map (2016 Pit Outline)

9.2.4 PhiSpy Survey (2013)

Following the second drilling campaign and the trenching of the VN3 showing, a PhiSpy survey was performed in December 2013 and March 2014 over the vicinity of the VN3 showing, the E3 anomaly, the mine pit and the Trench #3 area. The PhiSpy system is a versatile exploration tool similar to the IMAGEM method used in the past by Géosig. During the survey, shallow anomalies can then be dug out, investigated, and sampled immediately. Unlike small EM devices such as the Beep Mat, which are usually limited to an investigation depth of about 1 m, PhiSpy can reach much deeper conductors and records full TDEM decay curves that can be post-processed and analyzed to retrieve information about the conductance and geometry of the conductors. Paper letter and map reports on the PhiSpy work have been produced by the contractor.

The PhiSpy survey performed between December and March 2013 revealed 14 anomalies of varying size. Beep Mat prospecting was carried out on each anomaly. Five anomalies of significant size were detected. Two of the anomalies are related to the VN1 and VN2 showings, while another corresponds to the target of the third drill program (Section 10.3) that revealed two graphitic horizons. The results of the survey on Trench #3 detected the southern and eastern extensions to the VN1 and VN2 showings.

9.2.5 PhiSpy Survey E1 (2014)

In May 2014, a 320 by 320 m geophysics survey was completed over priority target E1, which had been identified by aerial geophysics (VTEM) conducted in 2013. The ground EM survey consisted of a PhiSpy grid with a line spacing of 20 m. This target is located 900 m north of the Miller Mine pit. The area surveyed is centered over a 180 m by 100 m strongly conductive VTEM anomaly that lies at the heart of the 400 m (radius) E1 VTEM target previously reported. The EM PhiSpy resulted in the identification of seven anomalies, ranging in size from a few meters up to 25 m. The near-surface anomalies are primarily located on the southwest part of the grid, whereas the structural features and airborne anomalies are located toward the northeast part of the grid (Figure 9-3).

A portable ground TDEM PhiSpy survey was performed on November 26th, 2014. Given the sparse forest in the area, it was possible to carry out this survey through the bush with no need for a network of lines to be cut. On the day of, a total of 5.6 km of PhiSpy data was acquired. This PhiSpy data was combined with previous PhiSpy data to provide a more robust geophysical interpretation (Figure 9-3).

The survey results show interpreted models of conductivity and chargeability. A total of 28 ground TDEM anomalies located in close proximity to the interpreted structural features were identified, 7 of which are of particular interest (EM-1; EM-3; EM-7; EM-8; EM-9; EM-25; EM-26). The others (EM-2; EM-12; EM-13; EM-14; EM-20 and EM-19) are respectively VN3, VN6, VN5, VN4, VN1 and VN2. Anomalies EM-5; EM-6; EM-21; EM-22 and EM-23 are onto historic pit or stockpiles. Trenching over EM-10, EM-11, EM-15, EM-16, EM-17, EM-18, and EM-24 revealed no visible graphite veins. Anomalies EM-4; EM-27 and EM-28 are in swamp areas and could not be accessed. The eight

interesting anomalies revealed either veins of graphite tens of centimeters thick (EM-3; EM-7; EM-8; EM-9; EM-25, EM-26) or metric pods of graphite (EM-1).

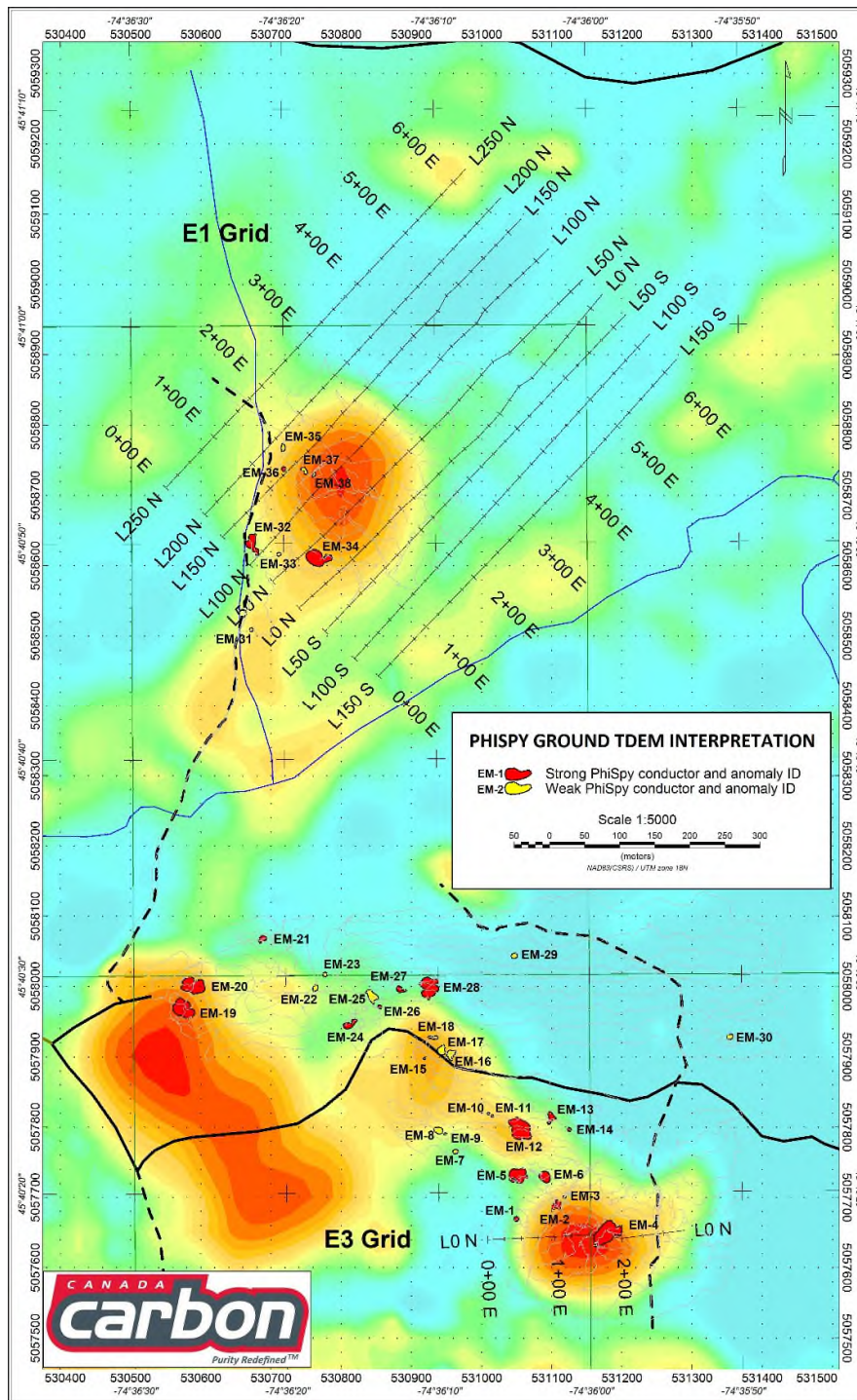

Figure 9-3: Ground TDEM PhiSpy Interpretation over Airborne TDEM

9.2.6 IP Survey (2014–2015)

IP survey was performed in two different phases. A first phase was performed from September 4 to 7, 2014, over the southern part of the area, and a second phase aimed at covering the northern extensions of several open anomalies occurred from May 3 to 5, 2015. The E3 south grid consists of 14 lines varying from 225 to 475 m in length, for a total of 4.725 km, and the E3 north grid consists of 5 lines of 750 m, for a total of 3.75 km.

The southern IP survey consisted of 14 lines, oriented in a southwest-northeast direction that covered an area of 650 m by 450 m. To fit to the Miller Property, the line lengths varied from 225 m to 475 m long, for a total of 4,725 m. The spacing between the grid lines was 50 m and the distance between pole and dipole was 12.5 m to obtain optimal resolution and depth of penetration. A total of 20 IP anomalies located in close proximity to the interpreted structural features were identified, 8 of which are of particular interest (E3-1; E3-2; E3-9; E3-10; E3-24; E3-25; E3-21 and E3-22; Figure 9-4). They all intersect known showings (VN1 to VN9) and seem to follow large conductors.

The northern IP survey consisted of four 480 m lines oriented in a southwest-northeast direction that covered an area of 500 m by 150 m. The spacing between the grid lines was 50 m and the distance between pole and dipole was 12.5 m to obtain optimal resolution and depth of penetration. The survey results show interpreted models of conductivity and chargeability. A total of eight IP anomalies located in close proximity to the interpreted structural features were identified, four of which are of particular interest (E1-4, E1-6, E1-7 and E1-8; Figure 9-5). Anomaly E1-4 is centered over the airborne VTEM anomaly, suggesting that its source could be common to both anomalies. Both the VTEM and the IP anomaly are located within a marble unit which is of interest since both the historic Miller Mine and the VN3 showing are hosted in marble. This anomaly connects at depth, with other anomalies present, and extends the width of the entire grid (150 m) in a northwest-southeast direction. Initial trenching has revealed graphite veins in the exposed bedrock surface. Anomaly E1-6 seems to come close to surface on line L150 (Figure 9-5). This anomaly lies on the contact between marble and paragneiss units. It follows the structural feature over the width of the whole grid (150 m). Both anomaly E1-7 and E1-8 are located in paragneiss outcrops, where graphite exposures were observed (Figure 9-5). Anomaly E1-7 is strong on lines L0 and L100, and seems to be sub-cropping on line 100, but appears to lie at a greater depth on line L0. Anomaly E1-8 is also of interest, but is only poorly defined since it is at the edge of the surveyed grid and its size remains undefined (Figure 9-5).

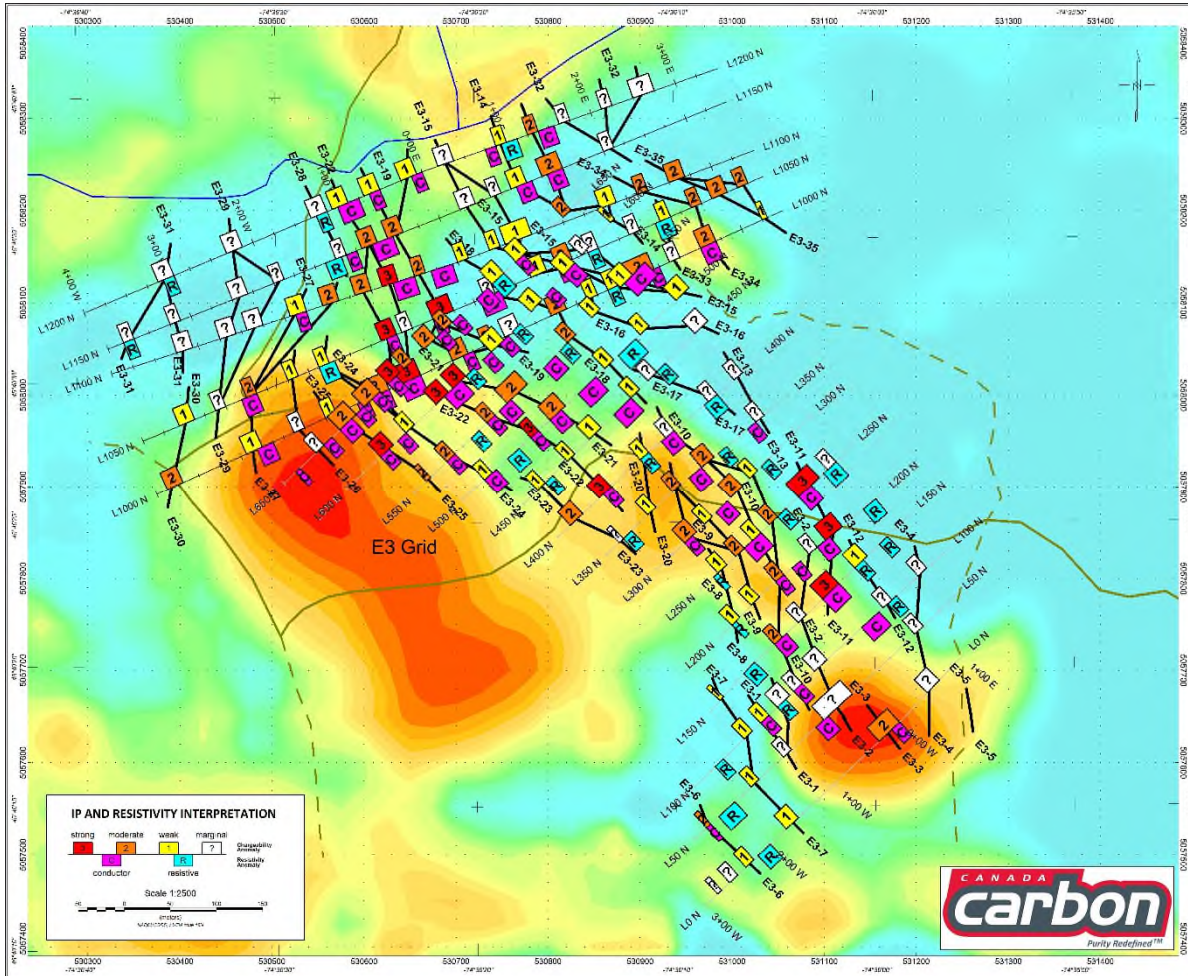

Figure 9-4: Resistivity and IP Interpretation over Airborne TDEM on the southern IP grid

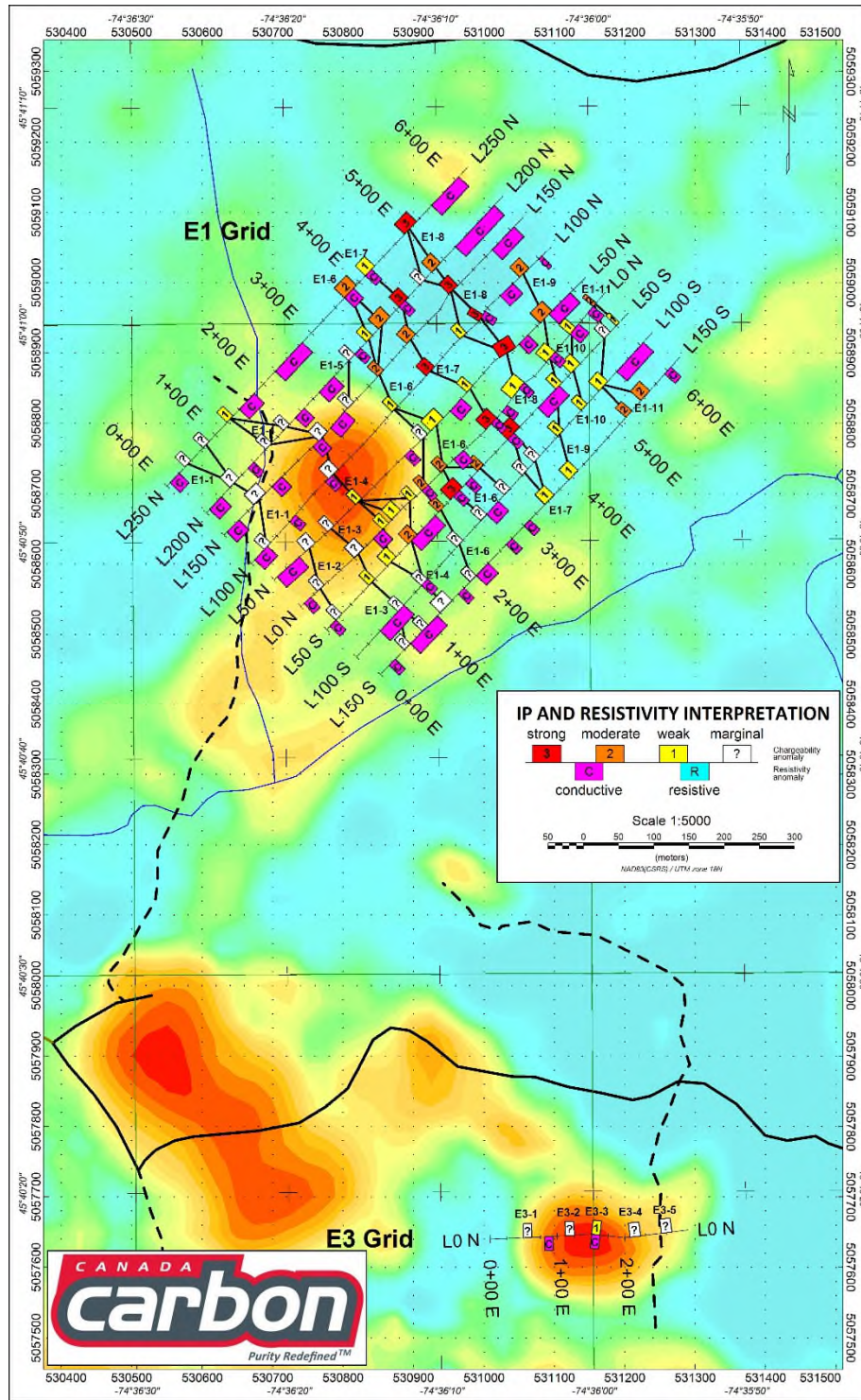

Figure 9-5: Resistivity and IP Interpretation over Airborne TDEM on the northern IP grid

Based on the IP, IMAGEM, Max-Min and other results provided by the geophysics surveys, Canada Carbon trenched every exploration anomaly to expose the bedrock. Additional ground EM surveying and trenching led to the identification of eight high-interest showings (VN1 to VN9, skipping VN5); (Figure 9-6, and Figure 9-7).

Although few outcrops are found on the Miller Property, numerous graphite mineralization examples were uncovered during prospecting phases. Numerous closely-spaced graphite veins ranging in width from several centimetres to tens of centimetres were discovered under the overburden. Some veins occur at the marble-paragneiss contact, in an identical geological context to that of the Miller Mine site and trench area. Several historic exploration pits were also located, with graphite-bearing blocks adjacent to them, apparently sourced from the pits. lists the location of trenches completed since 2014. Occasionally, the trench did not reach bedrock and therefore no observations could be made. Some anomalies also remain unexplained and require additional investigation.

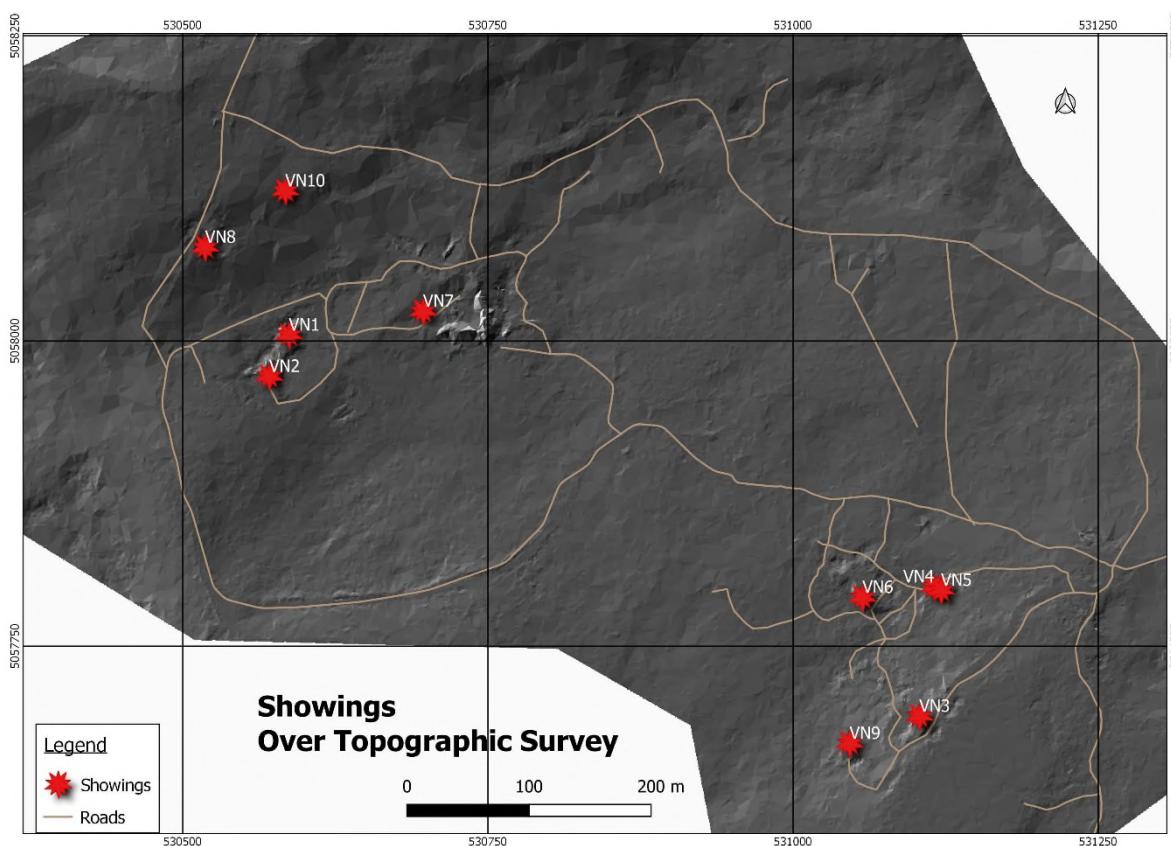

Figure 9-6: Location of Showings



Figure 9-7: Example of a Trenched Area with Banded Mineralization at VN6

9.2.7 VN1-2

Trenching on the combined IMAGEM, Beep-Mat and IP-1 anomalies in 2013 yielded some of the most interesting mineralization on the Miller Property. Graphite vein mineralization was exposed by mechanical stripping; revealing two high-grade showings (VN1 and VN2) located 200 m west of the Miller Mine pit. One of the two smaller initial trenches was extended to reveal the bedrock between the VN2 and the VN1 showings.

Subsequent trenching exposed the contact between marble and a paragneiss unit in the northeast part of the trench and between marble and a banded marble-paragneiss unit in the central and southeast parts. Coarse-grained skarns mark the contact and are spatially associated with mineralization: wide graphite veins and metre-scale graphite-wollastonite pods. The distinction between marble and skarn was based on diopside content. The marble displays variable degrees of silicification, increasing in intensity closer to the coarse skarn, to the point where marble at the contact forms a zone of “quartzite”. In the banded marble-paragneiss unit, the marble is visibly altered whereas

the paragneiss does not show signs of alteration at the macroscopic scale. The paragneiss unit at the northeast end of the trench also does not show visible signs of alteration.

A diabase dyke cuts across the other rock units. The diabase dyke is locally cut by graphite-filled faults. Coarse skarn completely fills the contact zone in the northeast part. The contact zone in the southeast part displays intense alteration and could not be described in detail because it corresponds to a depression filled with soil and calcite grains resulting from surface weathering.

Other metre-scale pods of graphite were also found scattered in the marble unit some distance away from any contact.

The VN1 showing is characterized by an irregular vein of semi-massive coarse graphite. The graphite vein is exposed along a strike length of 12.8 m, oriented northeast-southeast (148°) with a sub-vertical dip. From southeast to northwest, the vein ranges in width from 1 m to 1.7 m over a distance of 7.9 m, and of that length, the vein maintains a width of 1.6 m over 2.5 m. Toward the northwest, the vein is truncated where it encounters a 1.2 m zone of more competent host rocks. The width of the vein on the other side of the competent zone ranges from 10 cm to 1 m over a strike length of 3.7 m. Smaller graphite veins can be observed on both sides of the main vein, on available exposures. Finer grained graphite is locally present in the surrounding carbonate host rocks. The VN1 showing was covered by 1 to 3 m of glacial till.

Semi-massive coarse-grained graphite occurs within a coarse skarn-mineral envelope, which includes large crystals of white feldspar, diopside and wollastonite. Local geology consists of a complex intermixing of banded paragneiss and medium-grained carbonate rock (historically referred to as a marble unit), where contorted fragments of gneiss appear to float within an equigranular carbonate matrix.

The VN2 showing is characterized by a massive graphite vein up to 1.5 m thick that can be followed for more than 3 m at surface, several graphite pods, and multiple secondary graphite veins. The high-grade graphite veins and pods are aligned northeast-southwest and follow the contact between marble and paragneiss.

From the southern border of the trench, the contact can be followed at surface for more than 50 m and becomes folded toward the east. At depth, the mineralized contact was encountered 39.3 m below the VN2 showing.

9.2.8 VN3

A make-shift trench was excavated at the VN3 showing in the southern area of the Miller Property, close to a targeted VTEM anomaly. The showing was discovered when a vein was exposed while

moving the rig to the E3 drill site during the second drilling campaign. The bedrock was subsequently stripped to reveal a vein over 2 m wide that could be followed along strike for 5 m before pinching out.

9.2.9 VN4

The VN4 showing was exposed 120 m north of VN3 at PhiSpy anomalies EM-13 and EM-14. Excavation led to the discovery of two mineralized zones a few metres away from a contact between the marble and skarn. A sub-vertical diabase dyke is visible at the southern part of the outcrop, striking west at 80°.

The mineralization consists of two pods of coarse grained graphite. The first pod is about 1.5 m in size and is oriented northwest-southeast. It is a mix of amphibole, wollastonite, graphite and re-crystallized calcite, encased in the highly altered marble. Channel samples 61501 to 61504 are surface grabs that include material from both mineralization and host rock.

The second pod is located 3 m south and 2 m lower (topographically) and is 0.50 m in size. It is composed of coarse graphite in fine grained grey skarn.

9.2.10 VN6

The VN6 showing was exposed 120 m NNW of VN3 and 60m west of VN4, at PhiSpy anomaly EM-12. Trenching on VN6 has uncovered marble and graphite-rich skarn bands with widths over 7 m, which can be followed in the newly exposed bedrock surfaces for over 40 m (Figure 9-9). Similar mineralization is found in the VN6 Extension trench located 45 m along strike, suggesting that the skarn unit is continuous for at least 90 m (Figure 9-9).

The VN6 showing is characterized by a 2 m-large, 30 m long sheet mineralized horizon. Similar to a banded-iron formation, the sheet is layered graphite in a pyroxene-wollastonite-feldspar matrix (skarn). The surface expression of the mineralized layer is kinked and folds toward the northeast. Interpretations of drill core logs indicate a westward dip at a low angle. The mineralization is at a contact between the marble and skarn (Figure 9-9). Mineralization consists of coarse-grained graphite, from 1 mm to 10 mm in size.

At the northeast end of the outcrop is a diabase dyke, 50 cm wide, oriented 80° west (Figure 9-9). The projection of the dyke strike and dip is concordant with the dyke near VN4. Small kinks at the wall seem to indicate post-intrusion constraints.

At the southeast end is an important fault that cross-cuts the mineralization (Figure 9-9). The orientation is N090° similar to many other structures on the Miller Property. The actual displacement is not clear; the VN4 showing or an old pit tens of metres away could both be candidates of the extension.

Channel samples are surface grabs that include material from both mineralization and host rock. Graphite content varies from 0.3 to 19.8%. Results are summarized in Table 9-2.

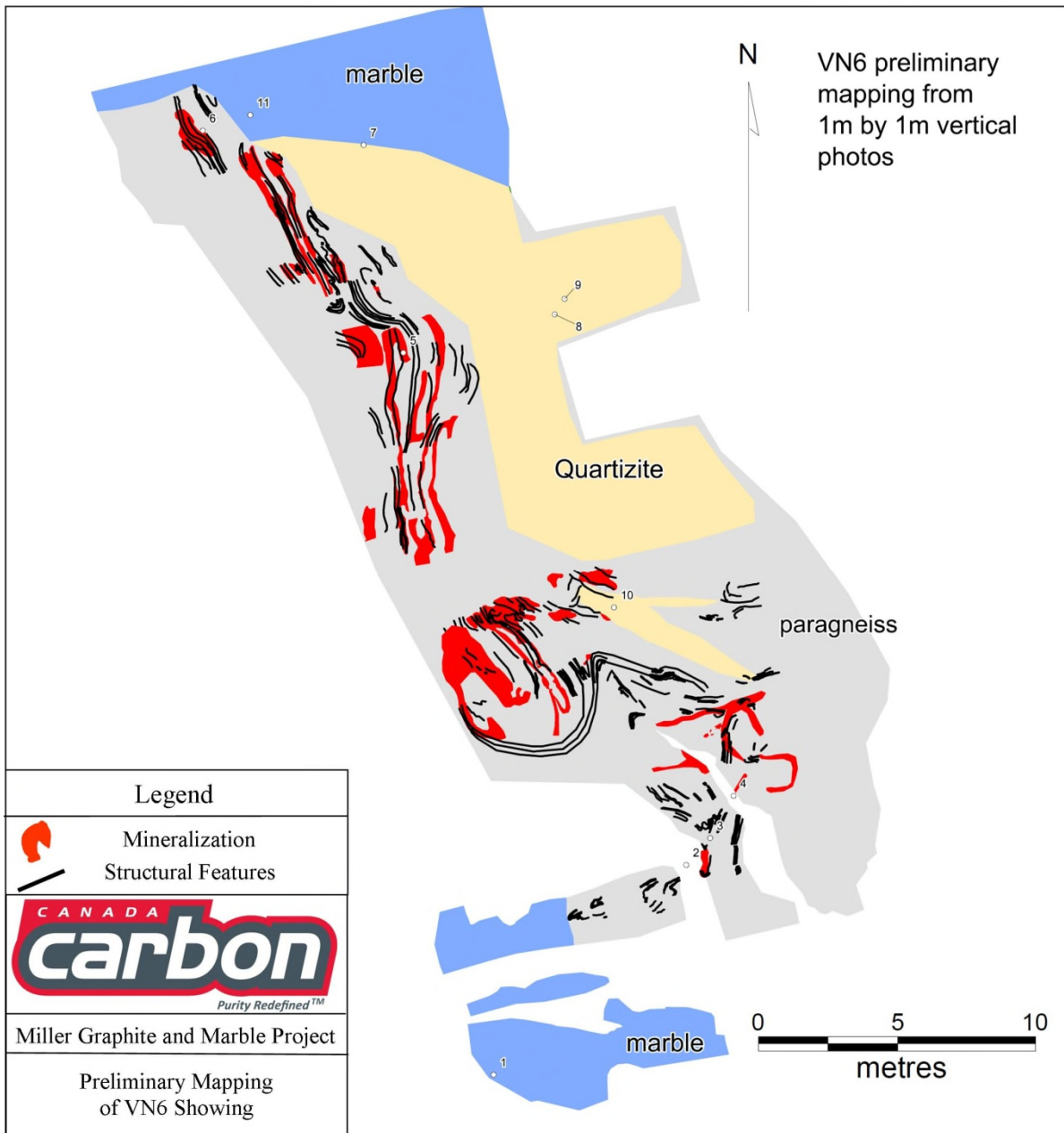

Figure 9-8: Preliminary Mapping of VN6 from Vertical Photos

9.2.11 VN7

The VN7 showing was exposed at the southeast tip of the right arm of the Miller Mine. The showing is located at conductive and chargeable anomalies E3-21 and E3-22. Excavation led to the discovery of a 2 by 5 m large mineralized horizon. The showing is a superposition of graphite and skarn layers, each of varying thicknesses (from 0.5 cm to tens of centimetres). The mineralization is at a contact between vertical layers of marble and skarns. The horizons are layered graphite in an amphibole-diopside-feldspar matrix (skarn). Mineralization consists of coarse grained graphite, from 1 to 10 mm in size. Several centimetre thick graphite veins are observed. The surface expression of the mineralized layer is oriented 45° and dips sharply.

9.2.12 VN8

The VN8 showing is located northwest of VN1, near the access road to the river. Excavation led to the discovery of a 2 by 20 m long mineralized horizon under about 1 m of soil. Both extensions are lost under the overburden, so the exact length is not well known. The host rock is the recrystallized marble unit, with disseminated millimetric grains of graphite. The mineralization is a stacking of graphite and skarn layers, each a few centimetres thick. It is heavily folded and arcing greatly. A very large (2 m) diabase dyke is visible, cutting across the mineralization. At least two shearing episodes are visible, cutting through both the graphite/skarn and the dyke.

9.2.13 VN9

West of VN3 is a small anomaly (EM-1). Drillhole DDH15-76 intersected only minor mineralization, so a larger trench was dug around the casing. Coarse feldspars with large crystals of graphite have been found at the northern tip of the trench while at the east is a 1 m pod of graphite.

9.2.14 Anomalies EM-16 and EM-17

At location L350N 000E to L350N 065E on the geophysical grid are two small EM anomalies (EM-16 and EM-17). Two trenches were done to make observations. The western part (from 000E to 025E) is a marble horizon with underlying fine-grained skarn. In the eastern part (from 050E to 065E), the bedrock is a fine grained green and white skarn. Centimetric veins of graphite are also visible in the skarn horizon.

Using the orientation and position of the diabase dyke at VN4/VN6, as well as the one at L600N 015E and in using a geophysical pseudosection, the dyke extension was inferred to be around L350 25E. The portion between the two outcrops was trenched but it filled with water in a matter of minutes, preventing direct cartography. Visual observation of blocs removed showed the presence of the diabase dyke.

9.2.15 Anomaly EM-22

An old pit, roughly 2 m in diameter is located at coordinate L400N 50W on the geophysics grid. Graphitic mineralization is observed in a skarn exposed by trenching on a small conductive anomaly (E3-22) located less than 10 m away. Folding has been observed on the outcrop.

9.2.16 Anomalies EM-22 and EM-23

Two small EM anomalies (EM-22 and EM-23) are located at L550N 035W on the geophysical grid. Trenching was done to record observations prior to drilling. The overburden is composed of mineralized blocks from ancient stockpile and soil approximately one metre thick. The bedrock is a 2 m marble cap, with disseminated graphite and millimetric graphite veins. An underlying skarn horizon was exposed. A coarse grained wollastonite and amphibole pod is visible in the fine grained silicate skarn. Disseminated graphite is also visible in the skarn horizon.

9.2.17 Anomaly E3-19

Location L600 015E was trenched to place a drillhole to reach a subsurface conductive anomaly (E3-19). A large amount of mineralized (disseminated graphite) marble was found. A diabase dyke 1.20 m thick oriented N130 and sub-vertical was observed. The orientation of S0 is interpreted to be N290°. Thin millimetric veinlets of graphite in the marble are oriented N315°. White skarn with large feldspars are located at the eastern end of the outcrop (at L600N 025E). No mineralization is visible in the skarn.

9.3 Channel Sampling

All channel samples were taken perpendicular to the orientation of the stratigraphy, schistosity, mineralization and/or any other visible continuous structure. Channel samples were between 2 to 3 cm in width, approximately 10 cm in depth and one metre long. Sample weights were between 5 to 10 kg. Channels were placed to sample marble where no nearby drillholes existed. They spanned the longest length possible within the trenches, with the objective of sampling both the mineralization and host rock. Figure 9-9 displays the location of the channel samples.

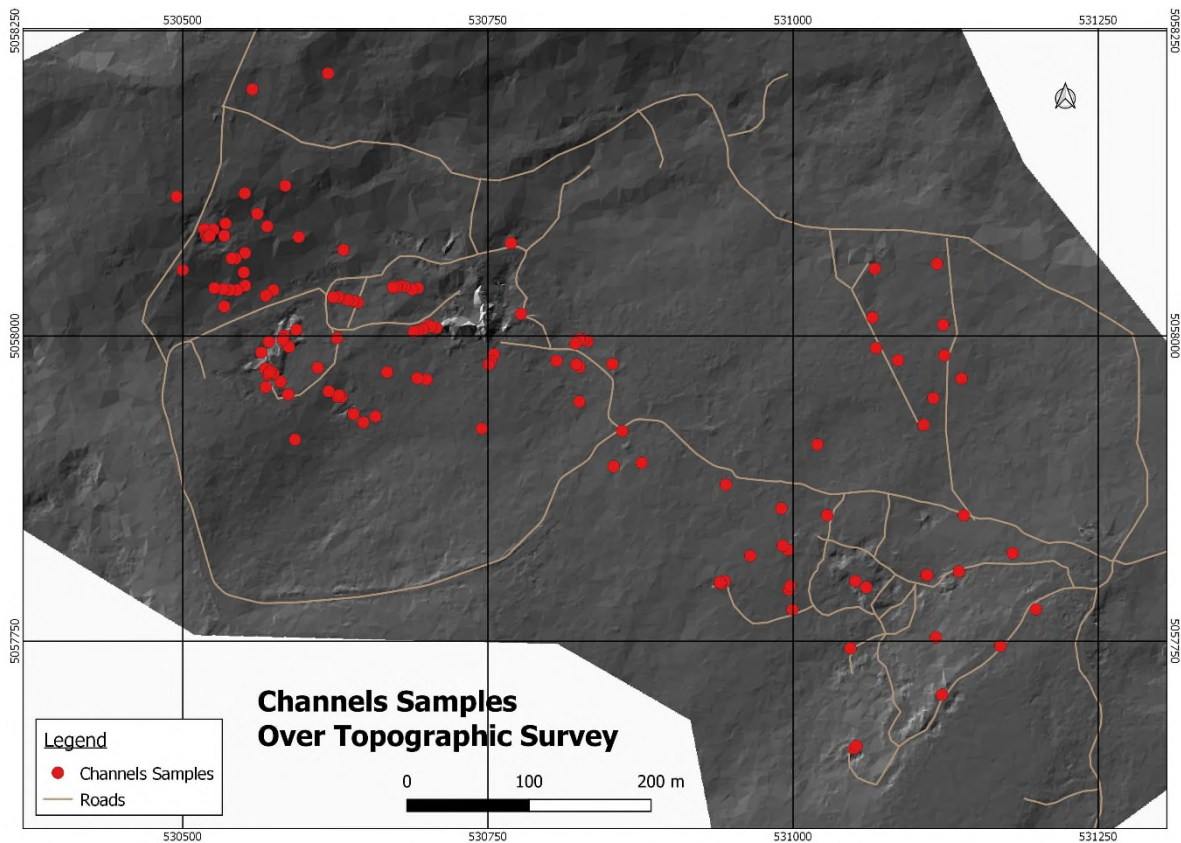

Figure 9-9: Location of Channel Samples

9.3.1 VN1-VN2

Four channels were taken at the VN1-VN2 showings (Table 9-1). They were aimed directly at the pods in an attempt to intersect the thickest part of the mineralization, perpendicular to the length.

9.3.2 VN4

Two channels were completed directly on the VN4 showing (Table 9-1), measuring about 1.5 m and 0.5 m in length. RN4-1 intersected coarse amphibole-wollastonite-graphite mineralization and RN4-1b, situated half a meter to the south, was placed on a richer part of the pod.

9.3.3 VN6

Two long channel samples (Table 9-1) were taken perpendicular to the mineralized layers. The locations were chosen as the thickest parts of the apparent section. Lengths in the rock were identified and pre-cut, 7 m long for the first one and 3.5 m long for the second. By the time the channels were completely cut, the water table had moved up and over the first metres, hampering their recovery.

They both cross-cut the lithologies near a contact between the marble and skarn. The horizon consisted of layered graphite in a fine-grained pyroxene-wollastonite-feldspar matrix (skarn). Mineralization consisted of coarse grained graphite, from 1 to 10 mm in size.

9.3.4 VN8

Small, metre-long channel samples were taken randomly along the mineralized sheet (Table 9-1). They were placed perpendicular to the lithologies at the contact between the marble and skarn. The mineralized horizon is layered graphite in a fine-grained pyroxene-wollastonite-feldspar matrix (skarn). Mineralization consisted of coarse grained graphite, from 1 to 10 mm in size.

Table 9-1: Channels and Grab Samples for the VN's

Hole ID	Azimuth (°)	From (m)	To (m)	Length (m)	Certificate No.	Assay Graphite (Gp%)	Sample No.
Pod #1	Grab	0.0	0.60	0.60	A13-11616	10.100	C18835
Pod VN1	N140	0.0	1.00	1.00	A13-11616	18.600	C18836
Pod VN1	N140	0.0	1.30	1.30	A13-11616	22.200	C18837
Pod VN1	N140	0.0	0.58	0.58	A13-11616	6.570	C18838
Pod #2	Grab	0.0	0.44	0.44	A13-11616	42.000	C18839
VN2	N220	0.0	1.30	1.30	A13-11616	28.200	C18841
VN2	N220	0.0	0.25	0.25	A13-11616	49.700	C18840
Pod #3 (VN2)	N270	0.0	0.65	0.65	A13-11616	12.500	C18842
Pod #3 (VN2)	N270	0.0	0.50	0.50	A13-11616	24.400	C18843
Pod #3 (VN2)	N270	0.0	0.50	0.50	A13-11616	17.700	C18844
Pod #4	Grab	0.0	0.50	0.50	A13-11616	33.000	C18845
Pod #4	Grab	-	-	-	A13-11616	5.590	18846
Pod #4	Grab	-	-	-	A13-11616	2.840	18847
RN4-1	N300	0	0.50	0.50	A14-10103	11.900	61501
RN4-1	N300	0.5	1.00	0.50	A14-10103	3.910	61502
RN4-1	N300	1.0	1.50	0.50	A14-10103	2.650	61503
RN4-1b	N300	0.0	0.50	0.50	A14-10103	9.720	61504
Channel 1 VN6	N070	0.0	0.50	0.50	N/A	N/A	N/A
Channel 1 VN6	N070	0.5	1.00	0.50	N/A	N/A	N/A
Channel 1 VN6	N070	1.0	2.00	1.00	A14-10103	0.330	61803
Channel 1 VN6	N070	2.0	3.00	1.00	A14-10103	19.800	61804
Channel 1 VN6	N070	3.0	4.00	1.00	A14-10103	8.080	61805
Channel 1 VN6	N070	4.0	5.00	1.00	A14-10103	7.610	61806
Channel 1 VN6	N070	5.0	6.00	1.00	A14-10103	10.000	61807

Hole ID	Azimuth (°)	From (m)	To (m)	Length (m)	Certificate No.	Assay Graphite (Gp%)	Sample No.
Channel 1 VN6	N070	6.0	7.00	1.00	A14-10103	8.430	61808
Channel 1 VN6	N070	7.0	8.00	1.00	A14-10103	0.470	61809
Channel RN6-1b	N070	0.0	1.00	1.00	N/A	N/A	N/A
Channel RN6-2	N070	0.0	0.50	0.50	A14-10103	7.560	61811
Channel RN6-2	N070	0.5	1.50	1.00	A14-10103	6.100	61812
Channel RN6-2	N070	1.5	2.50	1.00	A14-10103	7.320	61813
Channel RN6-2	N070	2.5	3.50	1.00	A14-10103	6.080	61814
Channel VN8-R1	Grab	0.0	1.00	1.00	A15-04793	6.480	77204
Channel VN8-R2	Grab	0.0	1.00	1.00	A15-04793	13.400	77205
Channel VN8-R3	Grab	0.0	1.00	1.00	A15-04793	4.300	77206
Channel VN8-R4	Grab	0.0	1.00	1.00	A15-04793	15.200	77207
R2017-VN10	N225	1	2	1	A17-08776	0.35	492451
R2017-VN10	N225	2	3	1	A17-08776	0.42	492452
R2017-VN10	N225	3	4	1	A17-08776	0.38	492453
R2017-VN10	N225	4	5	1	A17-08776	0.34	492454
R2017-VN10	N225	5	6	1	A17-08776	5.39	492455
R2017-VN10	N225	6	7	1	A17-08776	0.72	492456
R2017-VN10	N225	7	8	1	A17-08776	0.64	492457
R2017-VN10	N225	8	9	1	A17-08776	0.32	492458

9.3.5 Marble

An important part of the 2015 summer campaign focused on the determination of graphite content of the marble unit. Trenches were dug and channel samples were taken systematically in trenches (Table 9-2). They were placed directly above the horizontal projection of the end of a near diamond drill hole, between drillholes that intersected important lengths of marble and where the density of information was lower, or simply in any visible marble horizon at the surface, inside previously opened trenches.

Logging of diamond drill core and channel samples revealed a significant amount of white marble, with little alteration or color variation. This marble poses significant architectural stone potential. The area northeast of VN3 has been identified as the best sector for potential quarrying. Two large test samples (greater than 100 kg each) were collected with a Tramac in the VN3 area. They were sent to a monument builder in the Stanstead area to be cut and polished. They were deemed of sufficient quality to be of commercial value. Two larger blocks were collected, about two cubic meters each, and were sent for further testing and assaying.

Table 9-2: Marble Channels

ID	Easting	Northing	Target	Direction	Length (m)	Lithology	MX
R001	531086	5057980	T016	N025	2.0	Marble	GP
R002	531068	5077990	T017	N015	3.0	Marble	GP
R003	531065	5058015	T019	N020	2.0	Marble	GP
R004	531067	5058055	T023	N000	19.0	Marble	GP
R005	530769	5058076	-	N030	11.0	Marble	GP
R006	531118	5058059	-	N025	4.0	Marble	GP
R007	531123	5058009	-	N030	2.0	Marble	GP
R008	531124	5057984	-	N030	2.0	Marble	GP
R009	531138	5057965	T007	N020	1.5	Marble	GP
R010	531115	5057949	T006	N030	2.0	Marble	GP
R011	531107	5057927	T017	N030	6.0	Marble	GP
R012	530582	5057997	VN1	N060	4.0	Marble	GP
R013	530568	5057958	VN2	N090	8.0	Marble	GP
R014	530853	5057893	-	N110	1.0	Marble	GP
R015	530745	5057924	-	N135	9.0	Hematized Breccia	-
R016	530495	5058114	-	N005	2.0	Hematized Breccia	-
R017	530619	5058215	L1200-55w	N080	2.0	Skarn	-
R018	530557	5058202	L1200-125W	N000	2.0	Hematized Breccia	-
R019a	530557	5058202	L1200-125W	N120	2.0	Skarn	-
R019b	530557	5058202	VN7	N120	0.5	Skarn	-
R020a	530535	5058092	VN7	N090	6.0	Marble	GP
R20b	530535	5058092	VN8	N080	8.0	Skarn	-
R021a	531050	5057662	VN8	~N000	0.5	Skarn	-
R021b	531050	5057662	VN9	~N000	0.6	Skarn	-
R022	531047	5057744	VN9	N090	2.0	Marble	GP
R024	530852	5057977	-	N070	5.0	Skarn	-
R025	531028	5057853	-	N180	2.0	Marble	GP
R026	531140	5057853	-	N020	2.0	Skarn	-
R027	531199	5057776	-	N150	2.0	Marble	GP
R028	531136	5057807	-	N050	3.0	Marble	GP
R029	531180	5057822	-	N090	2.0	Marble	GP
R030	531117	5057753	-	N110	2.0	Marble	GP
R031	531170	5057746	-	N110	2.0	Marble	GP
R032	531122	5057706	-	N315	2.0	Marble	GP
R033	531020	5057911	-	N170	2.0	Marble	GP

ID	Easting	Northing	Target	Direction	Length (m)	Lithology	MX
R035	530945	5057878	-	N050	2.0	Skarn	-
R036	530876	5057896	-	N120	2.0	Marble	GP
R037	530825	5057946	-	N080	2.0	Marble	GP
R038	530658	5057934	-	N100	2.0	Skarn	-
R039	530592	5057915	-	N020	2.0	Skarn	-
R040	530627	5057950	-	N110	2.0	Marble	GP
R040b	530627	5057950	-	N110	1.0	Paragneiss	-
R041	530534	5058024	-	N070	2.0	Marble	GP
R042	530550	5058052	-	N170	2.0	Marble	GP
R043	530595	5058081	-	N020	2.0	Marble	GP
R044	530561	5058100	-	N080	2.0	Marble	GP

9.4 Bulk Sampling

In March 2013, Canada Carbon received permission to collect and ship up to 480 t of graphite-bearing material from its Miller Property in Quebec. According to the authorization granted by the MRN, the material could be extracted for mineralogical testing as well as for distribution to potential purchasers. The sample was to be collected between March 15 and September 15, 2014, and the results of the treatment were to be reported to the MERN by September 15, 2015. The objective of the bulk sample was to test the historically mined trench area of the Miller Property, along with multiple veins of graphite mineralization found over the area during field exploration by Canada Carbon. Stockpiles of graphitic material from historical production were also found in various areas around the former mine and could be sent out for the purpose of bulk sampling. The removal of surface material in the trench would also assist Canada Carbon to understand the distribution of graphite pods and veins along the mineralized contact.

Canada Carbon, in association with SGS (Lakefield) began pilot-scale processing of graphite material from the Miller Property. The primary objectives of the pilot plant operation were to generate larger quantities of graphite flotation concentrate for downstream evaluation, and to provide process data to facilitate future engineering studies. An initial 25 t composite was shipped to SGS Lakefield in mid-August 2014 for commissioning purposes. An additional 102 t of material from the Miller graphite mineralization was received by SGS on September 9, 2014 for pilot plant-scale flotation optimization.

The initial 25 t sample was selected for purposes of commissioning the pilot plant equipment at SGS (Lakefield). This sample was composed of graphitic material from multiple sites, selected by visual examination. Approximately 5 t of the material (20% of the bulk sample) were comprised of metre-

scale graphitic blocks excavated during the trenching over the VN1 and VN2 showings, which lie about 150 m west of the Miller pit. A further approximate 5 t (20%) of the material comprised of 0.3 to 1 m graphitic blocks excavated during the trenching over the VN3 showing, which lies about 500 m to the southeast of the Miller pit. The remaining approximate 15 t (60%) were obtained from the historic Miller stockpiles; hand-sorting and mechanical removal of gangue mineralization yielded blocks of 0.15 to 1 m dimensions.

The 102 t bulk sample comprised of graphitic blocks which were visually estimated to have graphite concentrations of 5% or more, intended to be representative of the lower grade material present on the Miller Property. Approximately 61 t of the material were obtained from the historic Miller stockpiles. A further 26 t (approximate) were provided by blocks excavated during trenching over the VN6 showing. The remaining 15 t (approximate) were provided by blocks excavated during trenching over the VN4 showing. Block sizes ranged from 10 cm to 2 m. The bulk sample processed includes material from all known significant surface exposures of graphite, and is therefore fully representative of the lower grade Miller hydrothermal graphite mineralization. Results were reported in Canada Carbon's press releases of September and October 2014.

In late 2014, a second bulk sample of about 20 t was taken. Emile Foucault Excavation Inc., a local business specializing in excavation and demolition, was contracted to use machines to excavate mineralization on the VN6 showing for bulk sampling. Under the supervision of a geologist, the Tramac demolished the layered graphite horizon, measuring approximately 1 m deep by 20 m long and 5 m wide. Large blocks (above 30 cm) were subsequently broken into smaller pieces until the largest blocks measured a maximum of 20 to 30 cm in diameter. Approximately 30 t of mobile material, mineralized or sterile, was created. Under the supervision of a geologist, the best material was hand-sorted and put into industrial bags (36 inch by 36 inch x 48 inch, 1,500 kg capacity). Each bag was about 1 t and 22 bags were filled. To measure the exact total amount of material, bags were loaded on a truck and weighed. The total mass was 21,500 kg of selected material to be sent for metallurgic testing by a private purchaser. The shipment was sent in early 2015 due to weather conditions. The issuer and the receiver signed a confidentiality agreement restricting the disclosure of the metallurgical results.

Marc-Antoine Laporte of SGS is of the opinion that hand sorting blocks of 20 to 30 cm could result in high grading the material compared to sampling an entire load closer to the smallest mining unit (SMU). However, metallurgical tests were also performed on lower grade mineralization.

10 DRILLING

Canada Carbon performed a number of drilling campaigns between 2013 and 2022 to test geophysical targets (conductors) and to extend identified surface graphite mineralization to depth. A total of 348 holes (including channels) were drilled on the Miller Property for a total 15,137 m. Four additional drill holes (VN1-01, VN1-02, VN2-01, VN2-02) were done in 2013, using a winky drill that targeted near surface mineralization. The results from the winky drill holes were not used in the resource estimate.

Table 10-1

Drill Program Year	Meterage of Drilling (m)
2013	1,145
2014	2,072
2015	2,525
2016	3,380
2017	2,315
2021	3,022
Channels	677
Total	15,137

The witness drill core boxes are stored onsite (Figure 10-2), in wooden racks. This site is accessible from the main road via a gated trail. A database of drill box locations is kept on site. Drill cores are transferred from the drill to a temporary core shack by the drillers. The boxes are opened by a technician, measured and photographed. Each hole is logged, registering the different lithologies, marble quality and assay intervals.

The drillholes are planned using geographic information system (GIS) software and the drillhole collar locations are placed on the field using a chaining method based on known location (differential global positioning system (DGPS) surveyed drillholes or base station). Front sights and back sights are placed using a magnetic compass. Drilling directions vary from one area to another (Figure 10-1) and no established grid has been used on the Miller Property. The drillholes were set on dips varying from -45 to -90°.

The drilling campaigns were planned by Steven Lauzier, P.Geo OGQ#1430. and the execution of the drilling, logging and sampling was conducted by SL Exploration Inc., with Downing Drilling and Foradrill performing the drill work. Final drill logs were reviewed by Steven Lauzier, P.Geo and the drilling data

was compiled in a Microsoft® Excel database by Steven Lauzier, P.Geo and Pierre-Alexandre Pelletier, P.Geo.

A total of 11,978 samples were initially taken from the different drillholes and sent for assay. The assays represent 14,546 m, which corresponds to 96% of the total length of the drillholes. All samples were assayed for graphitic carbon and the assay results were registered in a Microsoft® Excel database, which was later transferred to an Access based logging software. The initial sampling programs focused on high grade visible graphite mineralization. Following a change of exploration scope to both high grade and low grade disseminated mineralization, Canada Carbon resampled the missing length of drill core according to SGS’s recommendations.

The drilling companies have left some of the casings in the drillholes (Figure 10-3). Markers with drillhole identification, direction and dip are left in each hole when drilling is completed (Figure 10-3). The final drilling locations were surveyed using a DGPS and the surveying work was conducted by J L Corriveau & Assoc Inc.

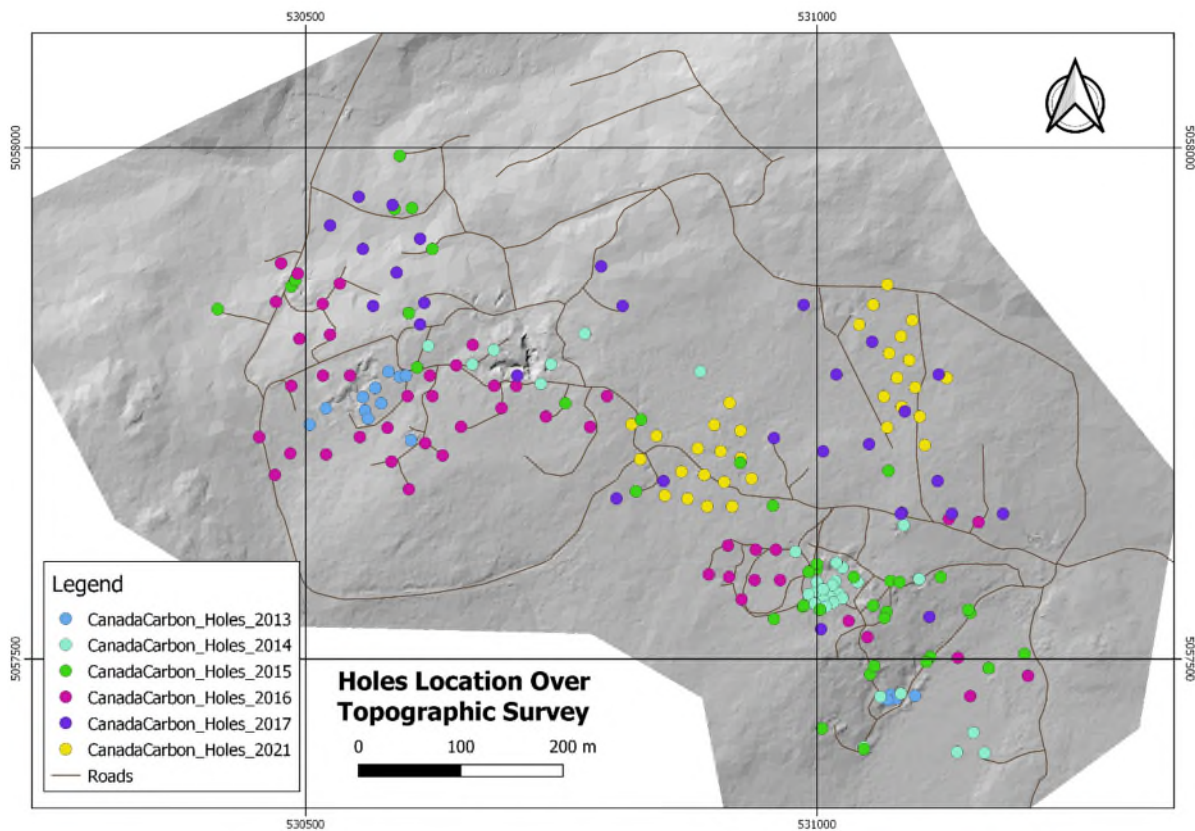

Figure 10-1: Location of Drillholes



Figure 10-2: Core Storage Area on Site



Figure 10-3: Example of Drillhole Markers

10.1 Drilling Campaign, July 2013

Canada Carbon's first drilling campaign of 12 holes totalling 594.9 m was carried out from late July to early August of 2013. The objective was to test the depth and lateral extent of the various veins. Downing Drilling was contracted to drill the VN1 and VN2 showings in August 2013. The firm used NQ size drilling rods for DDH13-01 to DDH13-08. One hole was attempted using a small portable drill (VN1-01) but was terminated in the first metre of drilling due to the hardness of the pegmatite. An on-track drill was then used to complete the other three planned short holes (VN1-02, VN2-01, and VN2-02).

The results of the drilling campaign demonstrate that the graphitic vein system extends to a depth of at least 39 m beneath the VN2 surface occurrences. Drilling intersected a graphite-wollastonite pod at 39.3 m (vertically) beneath the VN2 showing in hole DDH13-03, returning assays similar to the surface results, with 15.14% graphitic carbon over 0.9 m. Drill hole DDH13-04 laterally extended the graphite-wollastonite mineralization 14 m toward the east, and intersected 14.5% graphitic carbon over 0.5 m at 33.8 m (vertically) underground.

Some drillholes also tested the VN2 showing near surface. Drillhole VN02-01 encountered 32.45% graphitic carbon over 2 m from 1 to 3 m downhole, including two veins assaying 53.6% graphitic carbon over 0.3 m and 51.7% graphitic carbon over 0.9 m, respectively.

Many lower grade intersections were also encountered. Some of the lower grade mineralization includes graphitic marble or paragneiss grading between 0.46% and 5.27% graphitic carbon. Many rock units were crosscut by thin veins (2 to 5 cm).

10.2 Drilling Campaign, November 2013

Canada Carbon contracted George Downing Estate Drilling Ltd. in mid-November 2013 (Grenville-sur-la-Rouge, Quebec) to complete a 10-hole (551 m) NQ-sized diamond drilling program. The firm used a BoartLongyear LF70 rig with Interlock system. The objective was to extend the VN2 graphite mineralization at depth and along strike, and to drill-test three VTEM anomalies identified by the VTEM anomaly modelling. This hole was intended to sample below the graphite veins and pods observed in the trench area since previous drilling had already tested the continuity of the graphite veins. The winter campaign encountered bad weather, which slowed down drilling production.

Diamond drillhole (DDH)13-09 explained the E2 VTEM anomaly when it encountered a sulphide-rich intersection with minor disseminated graphite. DDH13-10 targeted the E3 anomaly and encountered a wide intersection of minor and disseminated graphite in marble.

While moving the rig to the E3 drill site, a graphite-rich vein (VN3) was exposed over a width of 2 m and a strike length of 5 m before pinching out. The VN3 discovery was drilled during the third campaign with six shallow drill holes that targeted the projected strike and depth extensions of the vein (see next section for details).

The most significant results were from the new vein discovery VN3 with 48.60% graphitic carbon over 1.8 m in DDH13-15, including 63.20% graphitic carbon over 0.5 m. This intersection of graphite mineralization occurs 4.6 m (vertically) below the VN3 showing. In turn, DDH13-14 intersected a graphite vein grading 50.50% over 0.30 m within a 3.50 m interval grading 6.80% graphitic carbon between the surface and the DDH13-15 graphite mineralization. The VN3 showing remained open at depth at the end of the drill campaign and was closed by subsequent drilling.

The other hole of interest is DDH13-11, which targeted the depth extension of a wollastonite-graphite pod located 22.5 m southeast of the VN2 showing in the trench area. The hole encountered another pod, thereby extending the mineralized contact hosting the pods to a vertical depth of 8.19 m below the surface showing. The hole yielded grades similar to other wollastonite-graphite pods, specifically 8.10% graphitic carbon over 2.3 m including 11.00% graphitic carbon over 0.90 m. The pod southeast of the VN2 showing is suspected to be within the same mineralized contact that extends to at least 39.3 m (vertically) beneath the VN2 showing. The mineralized contact also remains open at depth.

Many lower-grade intersections were also sampled during drilling. The best results were graphitic marble grading 2.00% over 10.50 m including 4.50 m at 3.50% graphitic carbon, and 1.00% over 13.00 m including 4.30 m at 1.6% graphitic carbon. Isolated values range between trace amounts of graphite and 4.00% graphitic carbon. No significant gold or base metal assays were obtained. Canada Carbon will use the litho-geochemistry data to establish alteration patterns and to better interpret the lithologies.

10.3 Drilling Campaign, 2014

Drilling of the new target revealed by the PhiSpy survey and the Geotech E3 target was done using a small portable drill (Gopher drill) from Downing Drilling due to the swampy nature of the drill pad. Two holes were drilled for a total of 64.5 m, targeting two anomalies provided by the PhiSpy survey. The anomalies are parallel, oriented north-south. The holes were drilled with a dip of 48° to the east.

10.4 Drilling Campaign, August 2014

Canada Carbon's August 2014 drilling campaign consisted of eight holes totaling 441.5 m. The objective was to test the depth and lateral extent of the various anomalies E1-4, E1-6, E1-7 and E1-9. Downing Drilling was contracted to drill the northern block about 800 m north of VN1. They completed drillholes DDH14-21 to DDH14-28 and produced BQ diameter core.

10.5 Drilling Campaign, September 2014

Canada Carbon contracted Downing Drilling in September 2014 (Grenville-sur-la-Rouge, Quebec) to complete a nine-hole (408 m) BQ-sized diamond drilling program. The objective was to extend the VN3 graphite mineralization at depth and along strike, and to drill-test three TDEM anomalies identified by the PhiSpy survey.

10.6 Drilling Campaign, October 2014

Canada Carbon contracted ForaDrill in October 2014 (Grenville-sur-la-Rouge, Quebec) to complete a 13-hole (640 m) BTW-sized diamond drilling program. The objective was to extend the VN6 graphite mineralization at depth and along strike, and to drill-test three TDEM anomalies identified by the PhiSpy survey.

Contrary to all the previous holes drilled parallel to the geophysical grid, a preferred orientation of 70° toward the north was chosen. Extensive trenching done during the summer combined with information from previous holes (DDH14-35, DDH14-36 and DDH14-37) revealed more details about the direction and schistosity of the rocks.

10.7 Drilling Campaign, November 2014

Canada Carbon contracted ForaDrill in November 2014 (Grenville-sur-la-Rouge, Quebec) to complete a 12-hole (518 m) BTW-sized diamond drilling program. The objective was to extend the VN6 graphite mineralization at depth and along strike, and to drill-test five TDEM and conductive anomalies identified by the previous survey.

10.8 Drilling Campaign, February 2015

Canada Carbon contracted ForaDrill in February 2015 to complete a 42-hole (2,525 m) BTW-sized diamond drilling program. The objective was to extend the VN6 graphite mineralization at depth and along strike, and to drill-test TDEM and conductive anomalies identified by the previous survey.

10.9 Drilling Campaign, Jan-Feb 2016

Canada Carbon contracted ForaDrill and Downing drilling in 2016 to complete a 47-hole (3,380 m) BTW-sized diamond drilling program. The objective was to extend and delineate graphite mineralization resources at depth and along strike, and to drill-test TDEM and conductive anomalies identified by the previous survey.

10.10 Drilling Campaign Summer 2017

Canada Carbon contracted ForaDrill and Downing drilling in 2017 to complete a 31-hole (2,315 m) BTW-sized diamond drilling program. The objective was to extend and delineate graphite mineralization resources at depth and along strike, and to drill-test TDEM and conductive anomalies identified by the previous survey. Great part of the drilling was to extend the VN8 mineralization and successfully revealed high grade graphite zone along strike and at depth.

10.11 Drilling Campaign Nov-Dec 2021

Canada Carbon contracted Downing drilling in 2021 to complete a 32-hole (3,022 m) NQ-sized diamond drilling program between November 29 and December 20. The objective was to delineate the marble unit and the graphite-rich skarn. Two zones were targeted: the eastern zone, for a definition of the marble pit as well as the western zone for a better definition of the graphite-rich skarn.

10.12 Channel Samples

During the different exploration campaigns, Canada Carbon conducted different phases of trenching and stripping in which channel samples were taken. The channel samples range in size from 0.5 to 1.5 m and are oriented according to the azimuth of the sampling direction and dip to follow the terrain features.

Channels were treated as drillholes, with each sample plotted along the trace of the channel. Normally, the channel sampling is conducted over known mineralization with the beginning and end of the channel being in the host rock (Figure 10-4). However, some channel samples only cover the mineralization portion of the rock formation.

A total of 519 channel samples were taken on the Miller Property, for a total of 677.58 m. Samples were photographed, described and bagged to be sent for assaying. In some cases, witness half channel samples were left in place (Figure 10-4).

The channel sampling program was planned by SL Exploration Inc. and executed under supervision of Steven Lauzier, P.Geo. The channel locations were surveyed using a regular GPS or the geophysics grid location. No identification markers are left in place at channel sampling sites.



Figure 10-4: Example of Channel Sample Witness (left) and Channel (right)

11 SAMPLE PREPARATION, ANALYSIS AND SECURITY

11.1 Sample Preparation

Prospecting work followed a protocol determined by Canada Carbon's technical team. To ensure samples and data were collected properly, a clear chain of custody of samples was established from the collection site to the laboratory.

Between 2013 and 2021, Canada Carbon sampled select intervals of drill core to assay, with the intent of highlighting high grade mineralization. One metre samples were taken over visibly graphitic mineralized core. Shorter samples were also taken in the richest zone to determine zonation within graphite pods. Longer samples were also taken when recovery was poor.

In 2015, Canada Carbon conducted a systematic drill core re-sampling campaign to obtain assays for the lower grade graphite mineralization that had not been sampled initially. The objective of this additional sampling was to generate a more complete graphite grade dataset for the Miller Deposit and ensure continuous sampling throughout the deposit. Sample preparation procedures for Canada Carbon are described in the following subsection. Quality assurance (QA)/quality control (QC) is described in Section 11.2.

Drill core was transported from the drill to the camp logging area with an all-terrain vehicle. Sample intervals were determined by the geologist during the geological logging process. Sample intervals were labelled with unique sequential sample identification numbers, on white plasticized paper tags, which were: 1) put into the sample bags; 2) left in the sample booklet, and 3) stapled to the core box.

Sample intervals were determined by the geological relationships observed in the core and limited to a 3 m maximum length with no minimum length. An attempt was made to terminate sample intervals at lithological and mineralization boundaries. Sampling was generally continuous from the top to the bottom of the drill hole following the 2015 core sampling program. 2016 and 2021 sampling program follow the same methodology.

Geological parameters were recorded based on defined sample intervals and/or drill run intervals (defined by the placement of a wooden block at the end of a core run). Drill logs were converted to a digital format and added to the database.

The drill core was photographed and then brought into the core shack where it was divided into sample intervals, split in half by a hydraulic splitter, and bagged by the core cutters. If core was not competent, it was split by using a spoon to transfer half of the core into the sample bag.

- Once the core was split, half was sent to Actlabs facility in Ancaster, Ontario, for analysis and the other half was initially stored at the camp. Shipment of core samples from the Miller camp occurred after completion of the splitting campaign. Rice bags, containing 10

to 15 poly-bagged core samples each, were marked and labelled with the Canada Carbon name, bag number, and sample numbers enclosed. Rice bags were secured with a tie-wrap for transport by courier or by truck directly to the Actlabs facility.

- In addition to the core, control samples were inserted into the shipments at the approximate rate of three standards (3%), one blank (1%) and four duplicates (4%) per 100 core samples:
- Standards: four different standards were used at the Miller Deposit. The core cutter inserted a sachet of the appropriate standard, as well as the sample tag, into the sample bag.
- Blanks: were composed of a standard void of mineralization. The core cutter inserted a sachet of the blank material, as well as the sample tag, into the sample bag.
- Duplicates: the core cutter split the sample in half, split the half again, and placed two quarter-splits in two separate bags with unique tags and left the witness half in the core box.

11.1.1 Core Drilling Sampling

Core samples were split in half on site and sent to Actlabs. Richer intersections were subdivided into vein and non-vein material. Quarter-splits of the non-vein material were sent to SGS in Lakefield, Ontario, for additional assaying and quarter-splits of the rest (vein material) were sent to Actlabs, which reported their results according to protocol 5D-C.

At Actlabs, the samples underwent preparation RX1-Graphitic, which is drying, crushing with up to 90% passing through a #10 square-mesh screen, riffle splitting (250 gram) and pulverizing to 95% passing a 105 µm square-mesh screen. Graphitic carbon was determined by multistage furnace treatment and infrared absorption, with a 0.05% detection limit using analysis package 4F-C-Graphitic.

SGS prepared the samples by crushing to 75% passing 2 mm, splitting (250 g) and pulverizing to 85% passing 75 µm square-mesh screen. Graphitic carbon was determined by calculating the difference from the carbon assay (after ashing) by tube furnace/coulometer minus the carbonate carbon (after ashing) by coulometry. The remainder of the core was tagged and stored on site.

11.1.2 Channel Sampling

All channel samples were taken perpendicular to the orientation of the veins or pods. Channel samples were sent to Actlabs. Actlabs' results are reported using preparation RX1-Graphitic in which the samples underwent drying, crushing with up to 90% passing through a #10 square-mesh screen, riffle splitting (250 g) and pulverizing to 95% passing a 105 µm square-mesh screen. Graphitic carbon was determined by multi-stage furnace treatment and infrared absorption, with a 0.05% detection limit using analysis package 4F-C-Graphitic.

11.2 QA/QC

Actlabs is an accredited laboratory meeting international standards International Organization for Standardization (ISO) 9001:2000 with certification:

- No. CERT-0032482
- The Canadian Association for Laboratory Accreditation Inc. Standard ISO/IFC170252005 accreditation No. A3200.

At the laboratory, samples are prepared using preparation RX1-Graphitic by drying, crushing (less than 7 kg) up to 90% passing 10 mesh, riffle splitting (250 g) and pulverizing (mild steel) to 95% passing 105 µm. Graphitic carbon assaying was completed by multistage furnace treatment and infrared absorption using analysis package 4F-C-Graphitic. A suite of 49 elements were also analyzed in select samples by aqua regia digestion and Varian inductively coupled plasma (ICP) analysis. The multi-element package 1E3 (AR+ICP) comprised gold, cadmium, copper, manganese, molybdenum, nickel, lead, zinc, aluminum, arsenic, boron, barium, beryllium, bismuth, calcium, cobalt, chromium, iron, gallium, mercury, potassium, lanthanum, magnesium, sodium, phosphorus, sulphur, antimony, scandium, strontium, titanium, tellurium, thallium, uranium, vanadium, tungsten, yttrium, and zirconium. Duplicate analyses were performed at the laboratory for the purposes of quality assurance and quality control. No other QA or QC program was established.

11.3 Verification of the QA/QC Data

The database transmitted by Canada Carbon contained graphite assay results for 179 blank samples, 471 field duplicates and 308 standards for the 2013 to 2021 exploration programs. The results were compiled and verified by the author to assess the laboratory performance and assay data reliability. It is noteworthy that, for the 2021 exploration program, no blank samples, only 19 field duplicates and 14 standards were received for 5 of the drillholes and no QAQC was received for the 26 other drillholes.

11.3.1 Blank Material Results

11.3.1.1 Blank Material between the 2013 and 2017 drill campaign

A total of 128 analytical blanks were analyzed during the 2013 to 2017 exploration programs. The blank chosen by Canada Carbon is composed of two standard materials (GS912-5 and CDN-BL-10: pulverized granite) with 0.1% total carbon and void of graphitic carbon.

From the 128 blanks analyzed, 99% of them returned values less than 0.3% total carbon (0% graphitic carbon), which is three times the methods detection limit. Figure 11-1 shows a plot of the variation of the analytical blanks with time. A total of 21 blank samples returned graphite carbon between 0.05 and 0.25% and one sample returned a value of 2.66% Cg that is not shown in the Figure 11-1.

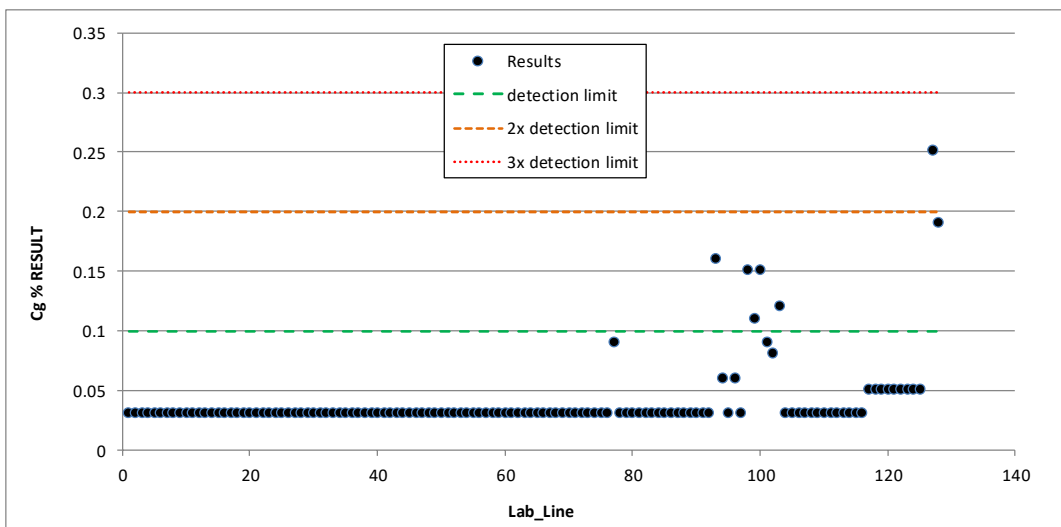

*A value of 2.66% Cg is not shown in the figure.

Figure 11-1: Laboratory Results for Blank Samples

11.3.1.2 Blank Material 2021 drill campaign

From the 51 blanks analyzed, 99% of them returned values less than 0.15% total carbon (0% graphitic carbon), which is three times the methods detection limit. Figure 11-2 shows a plot of the variation of the analytical blanks with time. A total of 2 blank samples returned graphite carbon between 0.05 and 0.27%. Figure 11-2 shows the blank sample results for 2021.

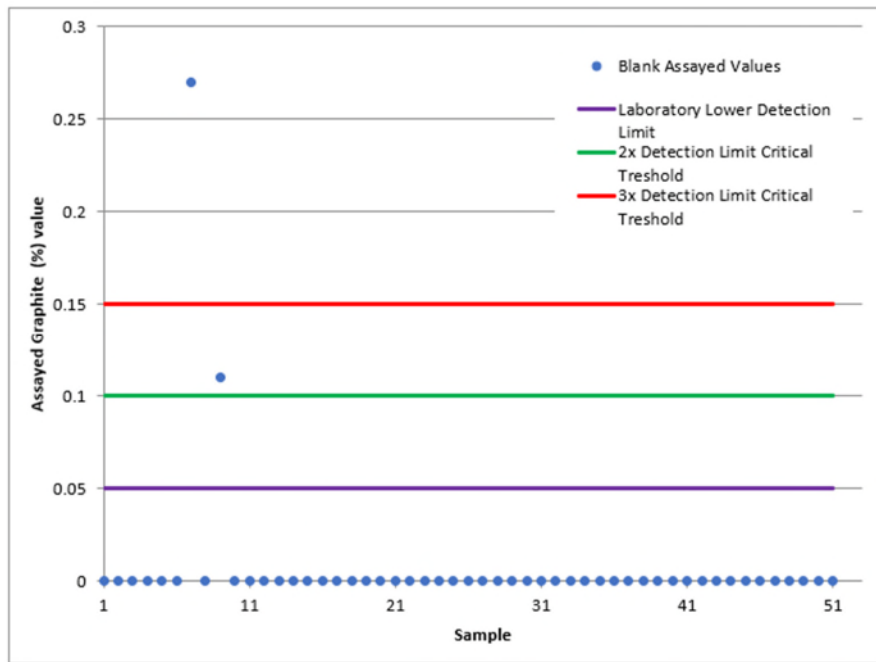

Figure 11-2: Laboratory Results for Blank Material 2021

11.3.2 Duplicate Material Results

Sample duplicates were inserted in the sample stream as part of Canada Carbon’s internal QA/QC protocol. The sample duplicates correspond to a quarter NQ or BTW core from the sample left behind for reference, or a representative channel sample from the secondary channel cut parallel to the main channel. Figure 11-3 shows correlation plots for the core duplicates.

From 2013 to 2017, a total of 338 duplicates results analyzed by Actlabs are available. From the 338 core duplicates analyzed only seven or 2.07% of the samples fall outside the $\pm 20\%$ range (Figure 11-3). The sign test for the duplicates does not show any bias (43% original < duplicate, 40% original > duplicate, and 17% original = duplicate). The mean of the percentages of difference is 0.49% (Figure 11-3).

From 2021, a total of 19 duplicates results are available. From the 19 core duplicates analyzed, six or 32% of the samples fall outside the $\pm 20\%$ range. The sign test for the duplicates does not show any bias. The relative difference of the averages is of -19%. (Original average is 0.71% graphitic carbon and the Duplicate average is 0.58% graphitic carbon) This is due to a single duplicate returning 2.56% graphitic carbon when the original was of 5.01% graphitic carbon. Without this sample, the average grade of the originals and the duplicates are the same.

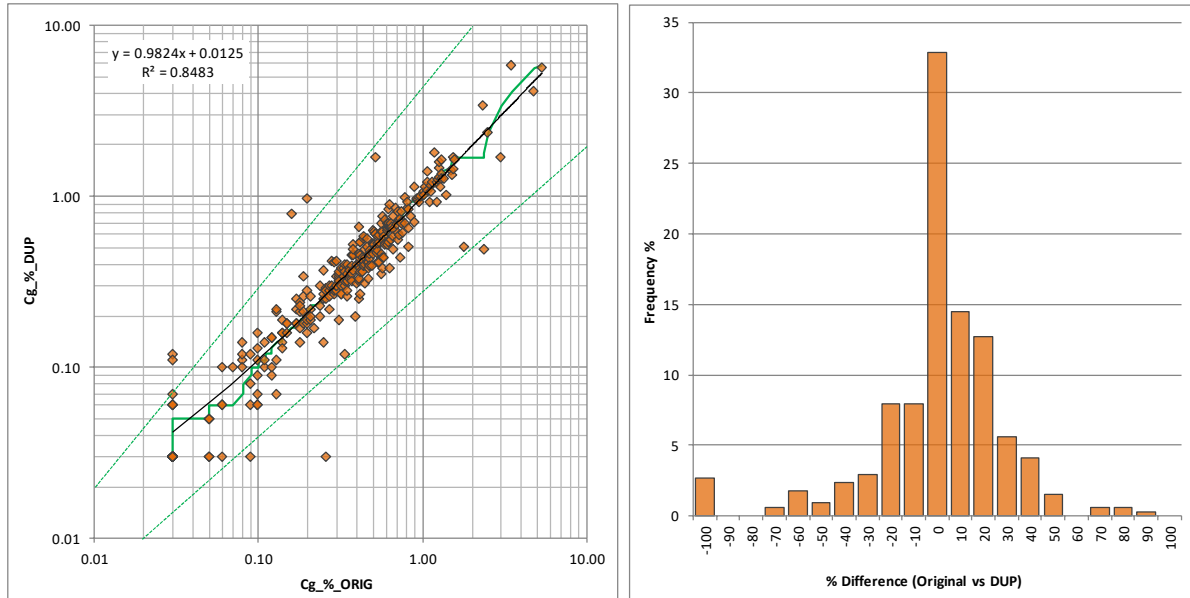

Figure 11-3: Laboratory Results for the Duplicate Samples 2013-2017

11.3.3 Standard Material Results

Four different standards were used by Canada Carbon for the internal QA/QC program: two low-grade graphitic carbon (less than 0.4% graphitic carbon; GCC-08 and GCC-07) and two high-grade graphitic carbon (greater than 2.4% graphitic carbon; GGC-04 and GGC-09) standards. All four standards were taken from reference materials bought on the market (Geostats PTY Ltd.) and are certified for using a leach process (for graphitic carbon) and a carbon/sulphur analyzer. There is 122 results for standard GCC-07 between 2013 and 2021 and no QA/QC failures observed.

A total of 103 high-grade standards and 127 low-grade standards were analyzed during the 2013 to 2017 exploration campaigns, representing 2.4% of the samples analyzed, which is under the industry’s standard for QA/QC. In order to determine the QC warning ($\pm 2x$ standard deviation) and QC failure ($\pm 3x$ standard deviation) intervals for the standards, the standard deviation parameters are derived from the certificates of the reference material.

From the 25 GGC-04 standards analyzed, none of the results fall outside the QC warning and QC failure intervals, as set by the certificate (Figure 11-4). The mean value of the reported grade is 13.48% graphitic carbon, which is slightly lower of the expected value of this standard (13.53%).

The GGC-09 standard was inserted a total of 76 times in the sample stream. Only one of the results from this standard is outside the QC warning ($\pm 2x$ standard deviation) limit but none of the results are

outside the fail QA/QC performance gates (Figure 11-4). However, a bias is observed in the results from GGC-09 standard. The mean value of the assay result is 2.70% graphitic carbon, with a standard deviation of 0.07, which is 12% higher than the expected value. This difference in results and expected value could be due to the different assaying method used in standard certification (leaching) and Canada Carbon’s assays (multi-stage furnace).

Standard GCC-08 was assayed 80 times and no QA/QC failures are observed (Figure 11-4). However, a bias is observed in the values; where the mean value of the assays is 0.44% graphitic carbon for an expected value of 0.39% graphitic carbon. One hundred percent of the assays are overestimated by an average of 12% (Figure 11-4). As for the GGC-09 standard, this bias could be due the different assay methods.

There are 44 results for standard GCC-07 and no QA/QC failures are observed (Figure 11-4). No bias is observed and the average value of the standards is 0.14% graphitic carbon, for an expected value of 0.13% graphitic carbon.

The 2021 data contained 14 more results for standard GCC-07 and no QA/QC failures are observed. The results range from 0.09 to 0.13% graphitic carbon with an average of 0.11% graphitic carbon.

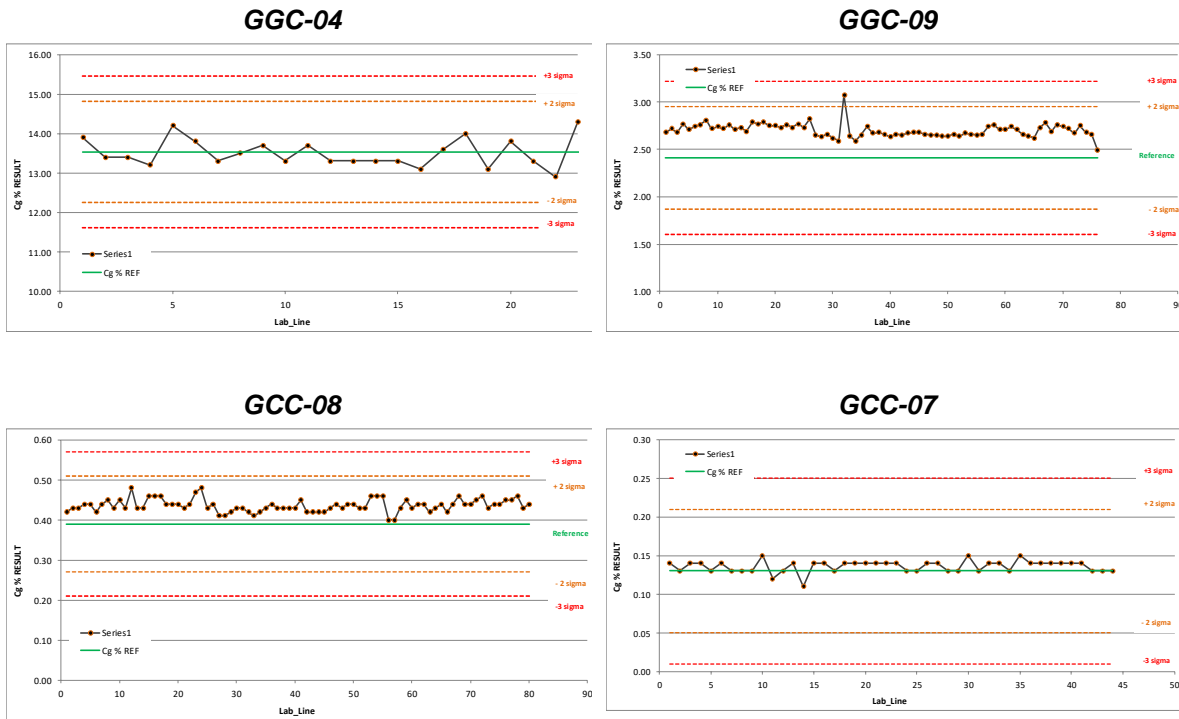

Figure 11-4: Laboratory Results for the Standard Samples

For 2021, a total of 78 low-grade standards were analyzed during the 2021 exploration campaign, representing 3.3% of the samples analyzed, which is under the industry’s standard for QA/QC. In order to determine the QC warning ($\pm 2x$ standard deviation) and QC failure ($\pm 3x$ standard deviation) intervals for the standards, the standard deviation parameters are derived from the certificates of the reference material.

For the 2021 campaign, there is 78 results for standard GCC-07. Expected results from the standard are $0.13\%Cg \pm 0.08\%Cg$ (equal to 2 times one standard deviation of $0.04\%Cg$). One of the results from this standard is outside the QC warning ($\pm 2x$ standard deviation) limit with a < 0.05 C-graphite content which is under the detection limit and probably due to a sample mix. All the other reported values fall within the expected threshold (Figure 11-5).

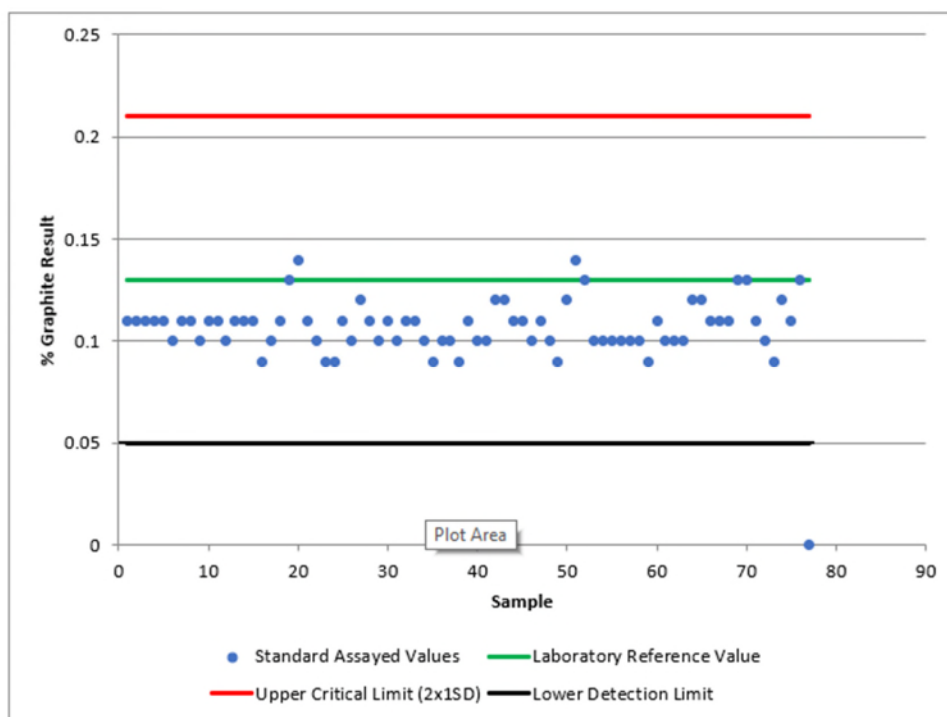

Figure 11-5: Laboratory Results for the GCC-07 Standard Samples

11.4 QA/QC Observations and Conclusions

Internal QA/QC results from Canada Carbon indicate good correlation ($R^2 = 0.85$) for the same core duplicates for the principal mineral of economic interest (graphite) for the 2013, 2014, 2015, 2016, 2017 and 2021 drill programs. All values derived from the insertion of blanks into the sample stream by Canada Carbon were within acceptable ranges. No assay values exceeded the QA/QC performance gate. However, biases are observed in two of the standards used in the QA/QC process. In both cases, the values seem to be overestimated by an average of 12%.

In SGS's opinion, the Project will benefit from more QA/QC samples included in the sample stream. The biases caused by possible assay method differences between standard certification and Canada Carbon assays should be investigated and corrected. The 12% overestimation of graphite grade could prove problematic especially for samples close to the economic cut-off grades.

The 2021 drilling campaign suffered from a lack of QA/QC samples and this is not to be repeated in the next drilling campaigns.

The data is considered acceptable for the estimation of Mineral Resources, but could affect the classification of the Mineral Resources as the QA/QC quantity is limited and the performance of the standards shows bias in two of the four standards.

12 DATA VERIFICATION

Marc-Antoine Laporte P.Geo., M.Sc of SGS visited the Miller Project on 7-8 of October, 2016, to obtain geological and structural information, followed by a second visit on August 1st 2018 to confirm the presence and GPS location of the 2017 drillholes. A site visit to the Miller Project was conducted by Yann Camus, P.Eng. on October 13, 2017 and on December 9, 2022. The observations and comments from those site visits are included in this part of the report. The visit enabled the author to become familiar with the exploration methods used by Canada Carbon, the field conditions, the position of the drillhole collars, the core storage and logging facilities and the different exploration targets. During the site visit, Yann Camus of SGS collected a total of 42 control samples from witness core stored on site.

The data validation was conducted from three fronts:

- validation of the drilling database
- validation of the QA/QC data (see Section 11.0)
- control sampling program.

12.1 Drilling Database

The database, which contained values for:

- 1) collar locations;
- 2) downhole surveys;
- 3) lithologies; and
- 4) assays with a graphitic carbon percentage

Was originally provided to SGS in Microsoft® Excel format with the 2013 to 2015 data. The drill campaign of 2016, was directly logged in the Geobase® software, creating a Microsoft® Access file. Then, a new file was provided for the 2017 data. Finally, a new file containing the 2021 data was provided in Microsoft® Access format. Upon importation of the data into the modeling and mineral resources estimation software (Genesis©), SGS conducted a second phase of data validation. Up to the day of the resource estimation, all the major discrepancies found were removed from the database. That said, some more questions were raised during the writing of this report and will have to be addressed in the future.

During the 2017 site visit, SGS gathered the location of 33 drillhole collars including 2 from 2014, 9 from 2015, 6 from 2016 and 16 from 2017. The azimuth and dip of the drillholes were also measured (taking into account the magnetic declination) for 12 of these holes. During the 2022 site visit, SGS gathered the location of 13 drillhole collars all from the 2021 drillhole batch along with the azimuth and dip for all of them. A handheld GPS device from Garmin was used with the WAAS correction always

available for the location readings. The XYZ were slightly adjusted on both visits to get a median shift of 0 in Easting, Northing and Elevation. A Silva Ranger Type15 compass was used to measure the azimuth and dip.

The Table 12-1 shows some discrepancies with the location of the drillhole DDH21-229 (highlighted in orange). The SGS reading with the GPS located the drillhole 25m away from the database location. Following the finding of the coordinate's discrepancy for the DDH21-229 hole, the Geode differential GPS from Canada Carbon containing the raw survey data was sent to SGS to assess the situation. The Geode coordinates seem to be correct and should be used until proven wrong. As seen in Table 12-2, the holes DDH21-228, DDH21-229, DDH21-230, DDH21-231, and DDH21-232 need most probably to have their coordinates corrected for the next resource estimation. Using the same table, we see that the collar DDH17-M06 also need to be verified since there might be a confusion with DDH17-M05.

The Table 12-1 also shows some discrepancies for holes DDH21-201, 205, 208, 209, 210, 218, 220, 224, 226 and 229 with the azimuths (highlighted in yellow). These 10 holes have important differences for some of the azimuths: usually the SGS-measured azimuth is very different from either the collar or the "first deviation" azimuth. This should be sorted out for the next resource estimation on the project. We also note that the collar azimuths are the "planned" azimuths and these should be replaced by some measured azimuths.

The Table 12-3 shows some discrepancies with the location of the drillholes DDH16-138, DDH17-158, and DDH16-148 (highlighted in orange). These collars need to be verified before the next resource estimation. SGS recommends that all casings that can be found in the field be surveyed using a GPS with enough precision like the Geode Sub-meter GPS Receiver or other similar or better.

The Table 12-3 also shows some discrepancies with the location of the drillholes DDH15-86, 87 and 88 (highlighted in blue). There seem to be a confusion between the 3 holes coordinates. The Figure 12-1 shows maps of the 3 holes as found in the database compared to how they are found in the field. Note that the azimuth and dip of the DDH15-87 was not measured in the field so it is assumed it would be confirmed in the field as it was the case with DDH15-86 and 88.

The Table 12-3 also shows some discrepancies for holes DDH15-88, DDH16-107, 111, 117, 138, DDH17-151, 152, 153, 158, 161, 195, 198, 203, M03, M04, M05, M06, M08, and M11 with the azimuths (highlighted in yellow). These 19 holes have important differences for some of the azimuths: usually the SGS-measured azimuth is very different from either the collar or the "first deviation" azimuth. This should be sorted out for the next resource estimation on the project. We also note that the collar azimuths are the "planned" azimuths and these should be replaced by some measured azimuths.

Table 12-1: 2022 Visit GPS and Compass Verification of 13 Collars (Suspicious Values in Colors)

GPS #	Hole Name	Database Collar					First Deviation			SGS GPS and Compass					Differences				
		X	Y	Z	Azi	Dip	Depth	Azi	Dip	X	Y	Z	Azi	Dip	Dist. (XY)	Diff.Z	Azi	Dip	3D angle
38	DDH21-201	531,086	5,057,957	213	215	-60	15	205	-58	531,081	5,057,952	210	222	-58	7	(2.59)	6.5	2	3.9
39	DDH21-208	531,080	5,057,979	214	215	-45	12	224	-44	531,079	5,057,980	211	243	-46	1	(2.74)	27.5	-1	19.2
40	DDH21-209	531,101	5,057,993	216	215	-45	15	216	-45	531,103	5,057,991	216	227	-45	2	0.14	11.5	0	8.1
41	DDH21-210	531,113	5,058,012	218	215	-45	12	219	-44	531,114	5,058,012	215	238	-45	1	(2.43)	22.5	0	15.9
42	DDH21-205	531,151	5,058,006	219	215	-45	12	217	-45	531,150	5,058,003	217	231	-44	2	(1.80)	15.5	1	11.1
43	DDH21-204	531,131	5,057,952	216	215	-45	51	220	-43	531,129	5,057,950	211	220	-44	2	(4.33)	4.5	1	3.4
44	DDH21-207	531,130	5,057,931	215	35	-60	12	38	-60	531,130	5,057,931	213	33	-60	1	(1.89)	-2.5	0	1.2
45	DDH21-218	530,952	5,057,870	212	215	-45	15	222	-43	530,952	5,057,869	212	229	-44	1	-	13.5	1	9.7
46	DDH21-220	530,928	5,057,872	213	215	-45	12	220	-44	530,928	5,057,876	215	232	-45	4	2.32	16.5	0	11.6
47	DDH21-224	530,920	5,057,901	213	215	-45	12	219	-44	530,917	5,057,900	213	228	-45	3	0.84	12.5	0	8.8
48	DDH21-226	530,884	5,057,886	213	215	-45	15	218	-45	530,882	5,057,887	215	226	-45	2	2.31	10.5	0	7.4
49	DDH21-225	530,941	5,057,926	212	215	-45	15	212	-45	530,941	5,057,928	216	222	-45	2	4.40	6.5	0	4.6
50	DDH21-229	530,903	5,057,908	212	215	-45	NA	NA	NA	530,917	5,057,928	222	230	-44	25	10.28	14.5	1	10.4

Table 12-2: Raw 2022 Geode GPS data vs Database

Hole Name	Geode			Database			Difference			Note
	X	Y	Z	X	Y	Z	X	Y	Z	
DDH17-M07	531,151	5,057,895	216	531,152	5,057,894	214	1	0	-2	
DDH17-M08	531,127	5,058,059	224	531,128	5,058,058	221	1	0	-3	
DDH17-M06	531,079	5,058,039	219	531,115	5,057,965	215	35	-74	-4	Geode XYZ fits DDH17-M05. To be verified
DDH17-M11	531,148	5,058,001	222	531,149	5,058,001	219	1	0	-3	
DDH21-201	531,086	5,057,957	213	531,086	5,057,957	213	0	0	0	
DDH21-202	531,112	5,057,977	217	531,112	5,057,977	215	0	0	-2	
DDH21-203	531,127	5,057,990	219	531,127	5,057,990	217	0	0	-3	
DDH21-204	531,131	5,057,952	219	531,131	5,057,952	216	0	0	-3	
DDH21-205	531,151	5,058,006	222	531,151	5,058,006	219	0	0	-3	
DDH21-207	531,130	5,057,931	216	531,130	5,057,931	215	0	0	-1	
DDH21-208	531,080	5,057,979	214	531,080	5,057,979	214	0	0	0	
DDH21-209	531,101	5,057,993	218	531,101	5,057,993	216	0	0	-2	
DDH21-210	531,113	5,058,012	219	531,113	5,058,012	218	0	0	-1	
DDH21-212	531,127	5,058,060	222	531,127	5,058,060	220	0	0	-2	
DDH21-213	531,116	5,058,052	222	531,116	5,058,052	219	0	0	-3	
DDH21-214	531,097	5,058,025	220	531,097	5,058,025	217	0	0	-3	
DDH21-215	531,071	5,058,054	219	531,071	5,058,054	217	0	0	-2	
DDH21-216	531,081	5,058,077	221	531,081	5,058,077	219	0	0	-3	
DDH21-217	531,096	5,058,093	224	531,096	5,058,093	222	0	0	-3	
DDH21-218	530,952	5,057,870	214	530,952	5,057,870	212	0	0	-1	
DDH21-219	530,964	5,057,892	215	530,964	5,057,892	212	0	0	-3	
DDH21-220	530,928	5,057,872	215	530,928	5,057,872	213	0	0	-2	
DDH21-221	530,946	5,057,903	212	530,946	5,057,903	212	0	0	0	
DDH21-222	530,953	5,057,918	212	530,953	5,057,918	212	0	0	0	
DDH21-223	530,906	5,057,885	215	530,906	5,057,885	213	0	0	-2	
DDH21-224	530,920	5,057,901	214	530,920	5,057,901	213	0	0	-1	
DDH21-225	530,941	5,057,926	214	530,941	5,057,926	212	0	0	-2	
DDH21-226	530,884	5,057,886	215	530,884	5,057,886	213	0	0	-2	
DDH21-228	530,903	5,057,908	214	530,950	5,057,949	213	47	41	-1	Errors in the database, use the Geode XYZ
DDH21-229	530,919	5,057,927	215	530,903	5,057,908	212	-16	-20	-3	
DDH21-230	530,934	5,057,960	214	530,919	5,057,927	212	-14	-33	-1	
DDH21-231	530,940	5,057,969	214	530,934	5,057,960	212	-6	-9	-1	
DDH21-232	530,859	5,057,918	216	530,940	5,057,969	214	81	51	-2	
DDH21-233	530,878	5,057,935	214	530,878	5,057,935	213	0	0	-1	
DDH21-236	530,851	5,057,942	216	530,851	5,057,942	214	0	0	-2	
DDH21-234	530,950	5,057,949	213	530,950	5,057,949	213	0	0	0	

Table 12-3: 2017 Visit GPS and Compass Verification of 33 Collars (Suspicious Values in Colors)

GPS #	Hole Name	Database Collar					First Deviation				SGS GPS and Compass					Differences				
		X	Y	Z	Azi	Dip	Depth	Azi	Dip	X	Y	Z	Azi	Dip	Dist. (XY)	Diff.Z	Azi	Dip	3D angle	
78	DDH16-138	530,513	5,057,924	200	215	-60	15	233	-61	530,517	5,057,916	183			9	(16.8)				
79	DDH16-111	530,548	5,057,923	202	215	-60	15	229	-61	530,544	5,057,920	204			5	2.1				
80	DDH17-203	530,554	5,058,142	169	215	-60	15	230	-59	530,553	5,058,147	161			5	(8.0)				
81	DDH17-151	530,579	5,058,171	167	215	-60	30	231	-61	530,579	5,058,170	167			1	(0.2)				
82	DDH17-152	530,612	5,058,159	171	215	-60	30	232	-62	530,609	5,058,165	169			6	(2.3)				
83	DDH17-153	530,641	5,058,135	178	215	-60	30	233	-61	530,642	5,058,138	172	217	-54	3	(6.4)	2	6	6	
84	DDH17-198	530,582	5,058,122	175	215	-60	30	223	-60	530,577	5,058,128	181	207	-58	8	5.7	-9	2	5	
85	DDH15-101	530,620	5,058,215	164	0	-90	51	0	-90	530,623	5,058,214	172	No Cas.		3	8.1				
86	DDH17-195	530,810	5,058,118	210	215	-60	14	232	-61	530,808	5,058,127	206	219	-59	9	(3.8)	4	1	2	
87	DDH17-188	530,837	5,058,069	217	215	-60	18	217	-60	530,839	5,058,074	217	207	-60	6	(0.4)	-9	0	4	
88	DDH14-56	530,801	5,058,041	210	225	-45	26	225	-45	530,799	5,058,044	213	No Cas.		4	2.7				
89/92	DDH16-108	530,734	5,057,990	211	0	-90	21	322	-88	530,732	5,057,996	215	0	-90	6	3.6	0	0	0	
90/91	DDH17-158	530,714	5,057,990	212	0	-60	30	12	-60	530,728	5,057,998	213	359	-60	16	1.7	-2	0	1	
93	DDH16-107	530,712	5,057,990	212	215	-60	45	233	-58	530,713	5,057,991	216			1	4.2				
94	DDH16-117	530,680	5,057,950	215	180	-60	15	200	-62	530,684	5,057,956	224			7	9.0				
102	DDH15-90	531,083	5,057,775	211	70	-45	70	70	-45	531,084	5,057,774	206			1	(4.9)				
103	DDH15-88	530,782	5,057,973	213	340	-45	72	340	-45	531,096	5,057,760	208	316	-45	379	(5.3)	-25	0	17	
104	DDH14-31	531,074	5,057,637	200	45	-45	51	45	-45	531,076	5,057,638	195	No Cas.		2	(4.7)				
105	DDH15-65	531,074	5,057,635	200	40	-50	69	40	-50	531,074	5,057,635	200	No Cas.		0	0.4				
106	DDH15-76	531,033	5,057,655	209	45	-45	71	45	-45	531,034	5,057,653	206	No Cas.		2	(2.9)				
107	DDH17-161	531,034	5,057,753	213	35	-70	30	44	-67	531,037	5,057,751	214	15	-65	3	1.0	-21	5	9	
108	DDH15-87	531,094	5,057,763	208	225	-45	72	225	-45	531,098	5,057,907	210			144	2.0				
109	DDH17-M02	531,076	5,057,936	213	45	-55	30	51	-60	531,076	5,057,937	208			1	(4.9)				
110	DDH17-M06	531,115	5,057,965	215	45	-55	24	57	-54	531,110	5,057,964	213	37	-52	5	(1.7)	-9	3	6	
111	DDH17-M11	531,149	5,058,001	219	45	-55	24	56	-54	531,147	5,058,001	223	33	-54	2	4.0	-13	1	7	
112	DDH17-M08	531,128	5,058,058	221	45	-55	24	56	-55	531,126	5,058,057	221	32	-55	3	0.0	-14	0	8	
113	DDH17-M05	531,081	5,058,038	221	45	-55	24	54	-54	531,080	5,058,038	216			1	(4.8)				
114	DDH17-M04	531,030	5,058,053	219	45	-55	30	62	-56	531,030	5,058,047	214			6	(5.2)				
115	DDH17-M03	531,054	5,058,004	214	45	-55	24	56	-55	531,057	5,058,003	220			3	6.4				
116	DDH15-89	531,020	5,057,808	211	70	-45	71	70	-45	531,022	5,057,811	209			4	(1.8)				
117	DDH15-86	531,098	5,057,907	213	135	-45	51	135	-45	530,787	5,057,979	218	163	-45	319	5.4	28	0	19	
118	DDH15-85	530,953	5,057,915	212	45	-45	48	45	-45	530,949	5,057,914	212			4	0.2				
119	DDH16-148	530,675	5,058,010	208	180	-60	9	185	-59	530,686	5,058,004	220	171	-58	12	11.9				

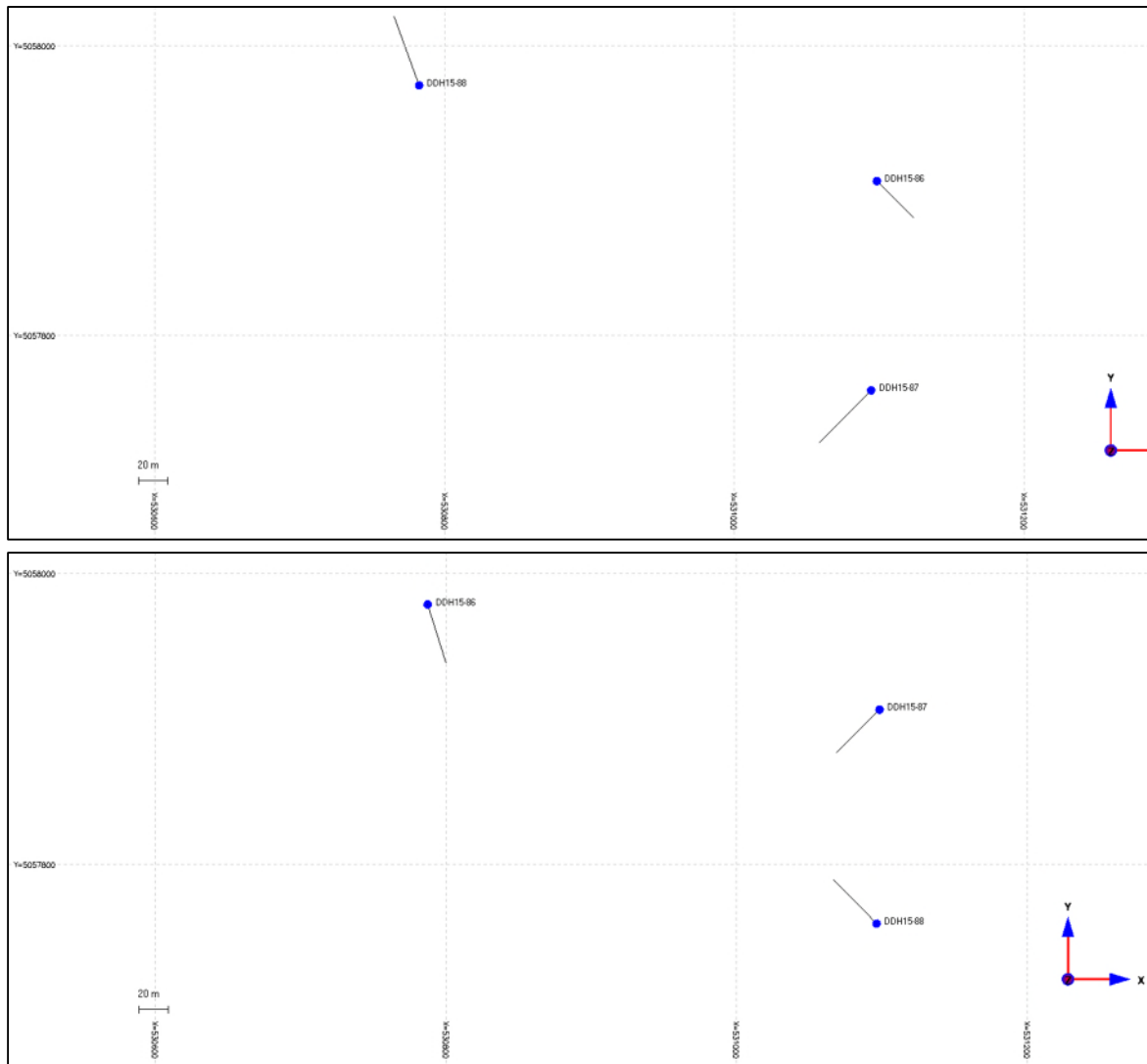

Figure 12-1: Holes DDH15-86, 87 and 88 as Found in the Database (Top) and in the Field (Bottom)

12.2 Control Sampling

During the 2015 site visit, SGS conducted a check sampling program, re-sampling a total of 41 core samples to verify the presence of graphite mineralization on the Miller Property. The conclusion presented in the previous technical report is that there is some variability in the results but no bias was identified.

During the 2017 site visit, Yann Camus gathered 42 samples from 2 mineralized intervals in the 2017 drillholes. The independent sampling was conducted by Canada Carbon’s technician under the

supervision of Yann Camus. The independent samples were taken back to SGS laboratories by Yann Camus.

A total of two mineralized intervals were sampled containing 42 samples (Table 12-4) to compare the average grade of the independent sample compared to the database grade. The difference in average grade varies by 5% overall with the database being conservative. There is a high variability on a sample per sample basis but it is mainly for samples below 2 %Cg as shown on Figure 12-3.

A bias is identified by the sign-test method but the Student-T test is inconclusive. The averages show that the grades used for the resource estimation are conservative so it is not a problem that could question the numbers. The high sample per sample variance could be explained by a sampling reason or the natural variance of the deposit. Further testing should be conducted in a further QA/QC program to establish the reason underlying this variance.

Table 12-4: Mineralized Interval Comparison between Canada Carbon and SGS

Canada Carbon Database						GS Independent Sample			Canada Carbon Database						SGS Independent Samples		
Hole Name	From (m)	To (m)	Len (m)	Sample Num.	Graph. C. (%)	Sample Number	Wt (kg)	Graph. Carb. (%)	Hole Name	From (m)	To (m)	Len (m)	Sample Num.	Graph. C. (%)	Sample Number	Wt (kg)	Graph. Carb. (%)
DDH17-M01	1.9	3	1.1	491166	1.31	492201	1.12	1.18	DDH17-154	25.5	27	1.5	492339	0.52	492223	1.23	0.42
DDH17-M01	3	4.5	1.5	491167	1.02	492202	1.57	0.79	DDH17-154	27	28.5	1.5	492341	1.22	492224	1.35	0.84
DDH17-M01	4.5	6	1.5	491168	1.23	492203	1.79	1.16	DDH17-154	28.5	30	1.5	492342	0.75	492225	1.43	0.68
DDH17-M01	6	7.5	1.5	491169	0.85	492204	1.68	0.68	DDH17-154	30	31.5	1.5	492343	1.23	492226	1.37	1.05
DDH17-M01	7.5	9	1.5	491170	1.1	492205	1.69	1	DDH17-154	31.5	33	1.5	492344	1.04	492227	1.43	0.99
DDH17-M01	9	10.5	1.5	491171	1.1	492206	1.78	0.93	DDH17-154	33	34.5	1.5	492345	1.22	492228	1.45	0.97
DDH17-M01	10.5	12	1.5	491173	0.85	492207	1.62	0.84	DDH17-154	34.5	36	1.5	492346	1.2	492229	1.25	1.06
DDH17-M01	12	13.5	1.5	491174	1.24	492208	1.57	1.17	DDH17-154	36	37.5	1.5	492347	0.93	492230	1.43	0.86
DDH17-M01	13.5	15	1.5	491175	2.54	492209	1.64	2.36	DDH17-154	37.5	39	1.5	492348	1.32	492231	1.13	1.05
DDH17-M01	15	16.5	1.5	491176	2.08	492210	1.54	2.69	DDH17-154	39	40.5	1.5	492350	1.25	492232	1.17	1.12
DDH17-M01	16.5	18	1.5	491177	0.43	492211	1.67	0.39	DDH17-154	40.5	42	1.5	228184	2.31	492233	0.94	1.89
DDH17-M01	18	19.5	1.5	491178	0.32	492212	1.26	0.28	DDH17-154	42	43.5	1.5	228185	1.21	492234	0.75	1.05
DDH17-M01	19.5	21	1.5	491179	0.14	492213	1.80	0.13	DDH17-154	60	61.5	1.5	228199	0.82	492235	1.76	2.04
DDH17-M01	21	22.5	1.5	491180	0.26	492214	1.63	0.27	DDH17-154	61.5	63	1.5	228200	0.72	492236	1.82	0.19
DDH17-M01	22.5	24	1.5	491181	1.35	492215	1.32	0.97	DDH17-154	63	64.5	1.5	228201	0.59	492237	1.50	0.95
DDH17-M01	24	25.5	1.5	491182	4.1	492216	2.00	4.3	DDH17-154	64.5	66	1.5	228202	0.05	492238	1.79	0.46
DDH17-M01	25.5	27	1.5	491183	2.02	492217	1.73	2.21	DDH17-154	66	67.5	1.5	228203	0.05	492239	2.02	0.97
DDH17-M01	27	28.5	1.5	491184	0.97	492218	1.58	0.96	DDH17-154	67.5	69	1.5	228204	0.05	492240	1.49	1.24
DDH17-M01	28.5	30	1.5	491185	1.37	492219	1.76	1.26	DDH17-154	69	70.5	1.5	228205	0.11	492241	1.75	1.52
DDH17-M01	30	31.5	1.5	491186	1.05	492220	1.51	1.14	DDH17-154	70.5	72	1.5	228206	0.1	462242	1.85	0.15
DDH17-154	22.5	24	1.5	492337	1.15	492221	1.36	0.96	Total			62.6		1.039	63.47	1.087	
DDH17-154	24	25.5	1.5	492338	0.56	492222	0.95	0.5	Relative difference:								+5%

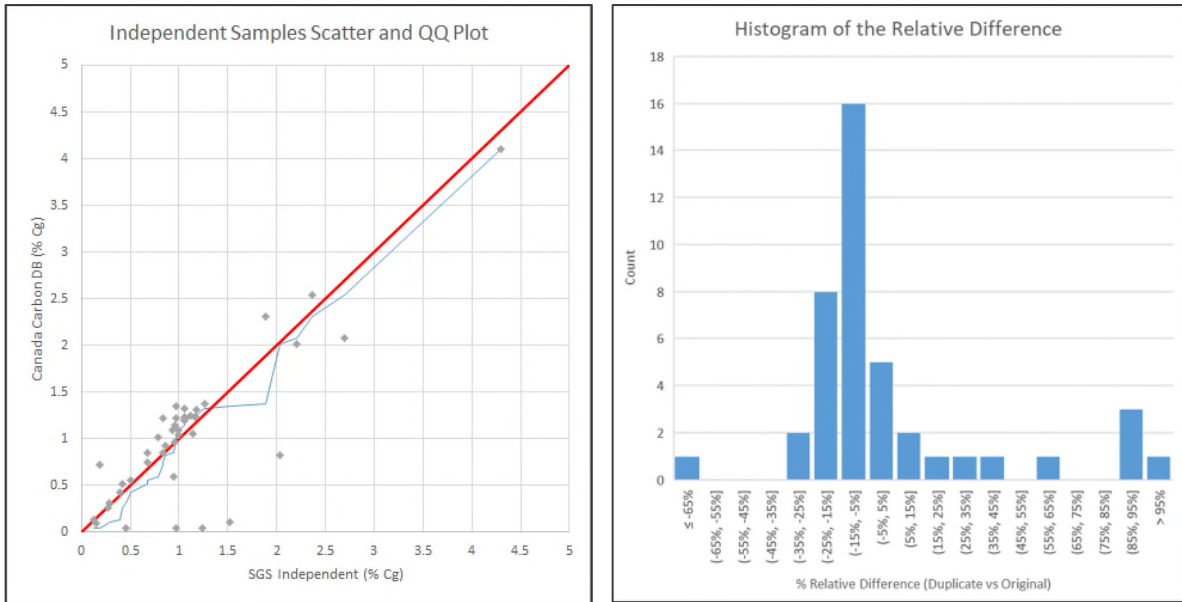

Figure 12-2: Independent Sampling : Scatter / QQ Plot / Differences Histogram

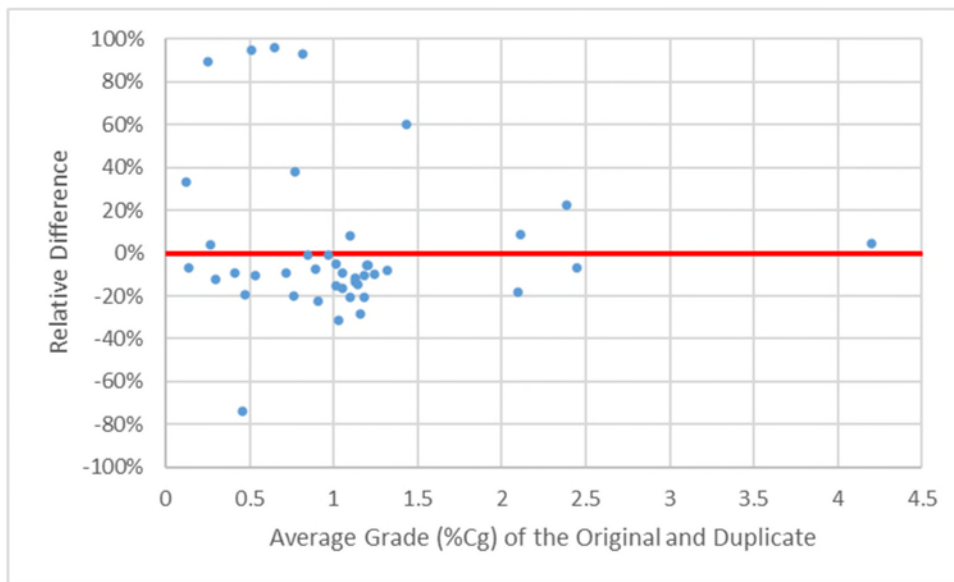

Figure 12-3: Independent Sampling: Difference per Grade

12.3 Conclusion

Following the data verification process and QA/QC review, the authors is of the opinion that the data produced by Canada Carbon during the exploration program is of sufficient quality to produce a Mineral Resource estimate. The QA/QC quantity could be increased to the industry's standard of 10 to 15% of the sampling. Furthermore, future sampling should continue to be conducted on all of the cores and samples should continue to be split in order to have the same quantity of mineralization in both half of the core. As some errors were encountered in the field during the site visits, all collars still available in the field should be re-surveyed using a sub-meter accuracy survey method and available casings should be measured for azimuth and dip for verification purpose. If any doubt remains on some of the drillholes, a down-the-hole survey tool should be used to verify the shape of the hole.

Recommendations will be made in Section 17 of the report in order to increase the sampling program performance and the integrity of the data collected by Canada Carbon.

13 MINERAL PROCESSING AND METALLURGICAL TESTING

This section is taken from chapter 13 in the report entitled: “Technical Report and Preliminary Economic Assessment for the Miller Graphite and Marble Property, Grenville Township, Quebec, Canada” published on March 4, 2016 by Tetra Tech.

13.1 Introduction

This section summarizes the metallurgical test work conducted for the Project. Two potential mineral values have been identified, namely graphite and marble.

13.2 Graphite

A total of five flotation testing programs, including a pilot plant campaign and several graphite concentrate upgrade tests were conducted using various samples originating from the Miller deposit. The flotation concentration test work was conducted by SGS in Lakefield, Ontario. Several graphite samples were subjected to flotation tests, as well as concentrate purification tests, glow-discharge mass-spectrometry (GDMS) analysis, and crystallinity determination by Raman spectroscopy.

13.2.1 Head Sample Chemical Analysis

The head assays for the samples that were evaluated in the five metallurgical programs are depicted in Table 13-1. The head grades varied significantly between 0.53% graphitic carbon and 61.2% graphitic carbon. This is reflective of the different domains that are encountered in the Project, ranging from low-grade disseminated mineralization to high-grade graphite veins.

Table 13-1: Head Grade Analysis

Test Program ID	C(t) (%)	Cg (%)	C(o) (%)	S (%)	Hg (ppm)
14185-001/002	65.1	61.2	<0.05	0.04	-
14185-003	41.6	-	-	-	-
14185-004	6.87	5.91	0.15	0.09	<0.3
14185-005	7.31	0.53	<0.05	0.62	-

Notes: C(t): total carbon; Cg: graphitic carbon; C(o): total organic carbon

All carbon analyses were performed by SGS at the Lakefield facility and are reported as total carbon by LECO or graphitic carbon employing a roast to burn off any organic carbon, followed by a leach to remove any carbonates and LECO assay of the leach residue.

13.2.2 Grindability Test

A Bond rod mill grindability test was carried out on the low-grade composite that yielded 0.53% graphitic carbon. The comminution test was carried out at the standard grind size of 14 mesh. The

Bond rod mill work index was determined to be 6.1 kWh/t, which is softer than 98% of the more than 2,600 samples in the SGS Bond rod mill grindability database.

13.2.3 Flotation Concentration Test

13.2.3.1 Batch Flotation Test

The first set of two laboratory flotation tests under Project 14185-001/002 evaluated the metallurgical performance of a vein graphite sample grading 61.3% graphitic carbon. The primary objectives of the flotation tests were to observe the metallurgical response of the Miller graphite to conventional grinding and flotation technologies and to generate samples for purification tests. The circuit consisted of a brief primary grind followed by flash flotation on the mill discharge. The purpose of the flash flotation stage was to recover any liberated coarse graphite flakes prior to the employment of more aggressive secondary grinding conditions. The flash flotation tailings were subjected to a secondary grind using steel rods followed by scavenger flotation. The combined rougher and scavenger concentrate was then subjected to polish grinding using ceramic media and cleaner flotation. In Test F2, three stages of polish grinding and cleaner flotation were employed. A typical reagent regime for graphite projects was employed in the tests and consisted of fuel oil #2 as the collector and methyl isobutyl carbinol (MIBC) as the frother.

The second test produced a concentrate grade of 93.2% total carbon at an open circuit with a carbon recovery of 97.2%. The results of the size fraction analysis of the 10th cleaner concentrate of Test F2 is presented in Table 13-2. All size fractions greater than 200 mesh yielded concentrate grades of 97.2% total carbon or higher. The majority of the impurities reported to the -200 mesh size fraction, which graded only 84.4% total carbon. The combined concentrate without the -200 mesh product graded 98.1% total carbon, containing 64.7% of the carbon units of the overall concentrate.

Table 13-2: Size Fraction Analysis of 10th Cleaner Concentrate (14185-001 F2)

Product - 10 th Cleaner Concentrate	Weight (%)	Assays (Cg%)	Distribution (Cg%)
+48 Mesh	11.0	100.1	11.9
+65 Mesh	10.1	99.1	10.8
+80 Mesh	6.3	97.6	6.6
+100 Mesh	7.5	96.8	7.8
+150 Mesh	13.7	97.4	14.4
+200 Mesh	12.7	97.2	13.3
-200 Mesh	38.7	84.4	35.3
Combined Concentrate	100.0	92.8	100.0
Combined +200 Mesh Fractions	61.3	98.1	64.7

While the results were preliminary in nature, they've provided two valuable insights. Firstly, the fact that the coarser flakes could be upgraded to over 97% total carbon using traditional mineral processing technologies may suggest that the impurities are attached to the outside of the flakes rather than being intercalated within the flake structure. Secondly, the mechanical manipulation that is required for the removal of the impurities is a function of the flake size. It is postulated that in order to achieve high concentrate grades in the smaller size fraction more mechanical manipulation and possibly a different grinding process may be required.

The second metallurgical program for the Miller project was carried out on a 51 kg sample, which was comprised of sub-samples from several different areas of the graphite target. The first sub-sample of 15 kg comprised stockpiled lump graphite remains from the original Miller Mine. The second sub-sample of 36 kg was obtained by cutting the vein with a rock saw from the VN3 mineralization exposed on the surface.

The primary objective of the test program was to develop a conceptual flowsheet for the Miller graphite mineralization that produces a saleable concentrate grading at least 95% total carbon while minimizing flake degradation. The program consisted of seven open circuit flotation tests, which culminated in the flowsheet that is depicted in Figure 13-1. The process flowsheet can be summarized as flash and rougher flotation followed by primary polishing and cleaning of the combined flash and rougher concentrate. The cleaner concentrate of the primary cleaning circuit is then subjected to classification into three size fractions of +48 mesh, -48/+100 mesh, and -100 mesh followed by polishing and cleaning circuits for each size fraction. The separate cleaning of three size fractions was chosen to address the different grinding energy requirements of the various graphite flake sizes.

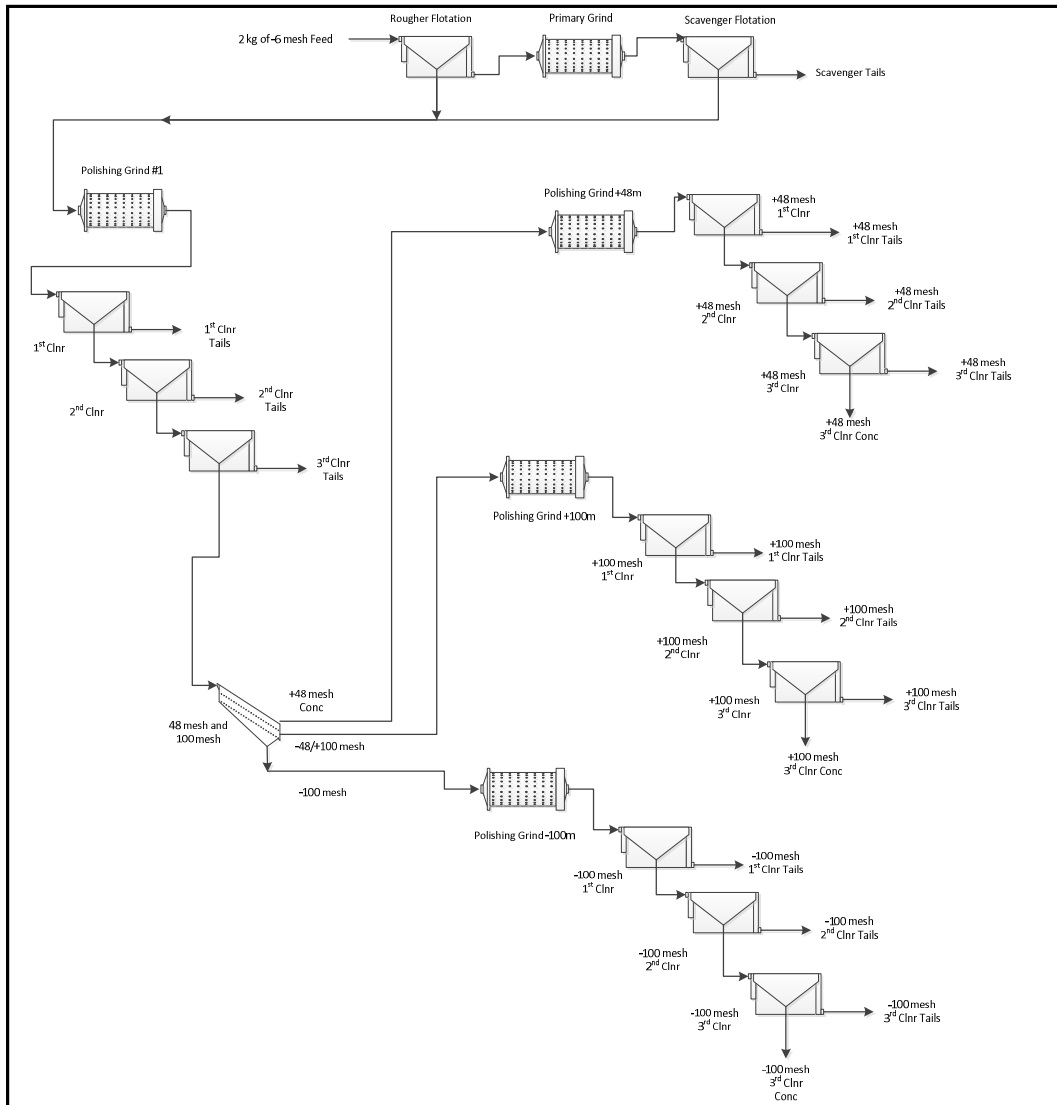

Figure 13-1: Conceptual Flowsheet for Miller Graphite Mineralization (14185-003, Test F7)

Test F7 produced a graphite concentrate yielding 97.0% total carbon at a graphite recovery of 90.2%. The size fraction analysis for the combined concentrate is presented in Table 13-3. The data reveals that all size fractions greater than 400 mesh produced grades of 96.1% total carbon or higher, averaging 98.2% total carbon. The majority of the impurities reported to the finer than 400 mesh product grading 89.8% total carbon. It should be noted that 31.1% of the mass reported to the +65 mesh size fractions at an average grade of 99.6% total carbon.

Table 13-3: Size Fraction Analysis Results for Test F7 (14185-003)

Product - 3 rd Cleaner Concentrate	Weight (%)	Assays (Cg%)	Distribution (Cg%)
+32 Mesh	3.6	100.0	3.7
+48 Mesh	13.5	99.6	13.9
+65 Mesh	14.0	99.5	14.3
+80 Mesh	7.9	97.9	8.0
+100 Mesh	11.0	98.4	11.2
+150 Mesh	8.3	97.4	8.3
+200 Mesh	10.4	98.1	10.5
+325 Mesh	13.0	96.4	12.9
+400 Mesh	4.6	96.1	4.6
-400 Mesh	13.7	89.8	12.7
Combined Concentrate	100.0	97.1	100.0
Combined +400 Mesh Fractions	86.3	98.2	87.3

Due to the need to generate significant quantities of graphite concentrate for downstream testing, a decision was made to proceed with pilot plant testing based on the results of the 14185-003 test program. The results of the pilot plant campaign are discussed in the following section.

The Miller graphite prospect is characterized by areas with disseminated low-grade graphite mineralization surrounding the vein structures. This disseminated graphite yields significantly lower graphite head grades. In order to assess the metallurgical response of the disseminated graphite, two open circuit cleaner flotation tests were carried out under SGS Project 14185-005 on a sample grading 0.53% graphitic carbon.

The same flowsheet that was developed under 14185-003 was employed in the two tests. The only difference was an adjustment of the classification sizes from 48 mesh and 100 mesh to 80 mesh and 200 mesh, which was the results of an optimization program carried out during the pilot plant campaign.

Despite the lower head grade of only 0.53% graphitic carbon, a combined concentrate grade of 96.4% total carbon at 90.1% open circuit carbon recovery was achieved. As in previous tests, the majority of the impurities reported to the finer size fractions. All products larger than 200 mesh yielded grades of 97.0% total carbon or higher. The full size fraction analysis is depicted in Table 13-4. The +200 mesh size fractions graded 97.8% total carbon and represented 76.9% of the total concentrate mass.

Table 13-4: Size Fraction Analysis of Combined Concentrate for 0.53% Graphitic Carbon Feed Sample (14185-005, F2)

Product - 3 rd Cleaner Concentrate	Weight (%)	Assays (Cg%)	Distribution (Cg%)
+48 Mesh	33.2	98.8	34.1
+65 Mesh	14.2	97.0	14.3
+80 Mesh	6.2	96.8	6.2
+100 Mesh	9.2	96.5	9.2
+150 Mesh	7.4	97.3	7.4
+200 Mesh	6.7	97.2	6.7
+325 Mesh	14.0	94.2	13.7
+400 Mesh	2.1	92.9	2.0
-400 Mesh	7.0	87.0	6.4
Combined Concentrate	100.0	96.4	100.0
Combined +200 Mesh Fractions	76.9	97.8	78.0

In conclusion, the three lab programs covered a wide range of head grades ranging from 0.53% graphitic carbon to 61.3% graphitic carbon. The metallurgical response was robust in that all size fractions greater than 200 mesh produced grades of at least 97% total carbon. The majority of the impurities reported to the -200 mesh product. A more detailed concentrate analysis that was conducted for the low-grade feed sample revealed that the concentrate grades decreased with each size fraction finer than 200 mesh and reached the minimum of 87.0% total carbon for the -400 mesh fines.

Pilot Flotation Test

During September and October 2014, a pilot plant campaign was conducted on approximately 127 t of a bulk sample from the Miller deposit. The information for bulk sample generation is detailed in Section 9.5. The flowsheet that was employed in the pilot plant was the conceptual flowsheet developed at the end of the 14185-003 program. The first run of the pilot plant campaign was based on the flowsheet and conditions of Test F7.

The primary objectives of the pilot plant campaign were (a) to produce graphite concentrates for downstream evaluation, (b) to demonstrate the robustness of the proposed flowsheet, and (c) to generate process data that can be used to develop the process design criteria for preliminary economic assessment and feasibility study purposes. As shown in Table 13-5, the average head assay on the pilot plant composite indicates that the composite contained 6.78% total carbon, including 5.91% graphitic carbon, and 0.15% total organic carbon. Total sulphur content was 0.09% and the ICP scan did not reveal elevated concentrations of deleterious elements.

Table 13-5: Head Assay – Pilot Plant Test Composite

Element	Unit	Head Sample
LECO		
C(t)	%	6.78
C(g)	%	5.91
S	%	0.09
CO ₂	%	2.83
C(o)-LECO	%	0.15
CVAA		
Hg	g/t	<0.3
ICP-OES		
B	g/t	48
Ag	g/t	<2
Al	g/t	44,800
As	g/t	<30
Ba	g/t	226
Be	g/t	1.28
Bi	g/t	<20
Ca	g/t	146,000
Cd	g/t	<2
Co	g/t	<10
Cr	g/t	98
Cu	g/t	11.5

Element	Unit	Head Sample
ICP-OES (continued)		
Fe	g/t	23,400
K	g/t	13,900
Li	g/t	7
Mg	g/t	17,300
Mn	g/t	385
Mo	g/t	<5
Na	g/t	15,600
Ni	g/t	<20
P	g/t	407
Pb	g/t	<20
Sb	g/t	<10
Se	g/t	<30
Sn	g/t	<20
Sr	g/t	606
Ti	g/t	3,790
Tl	g/t	<30
U	g/t	<20
V	g/t	54
Y	g/t	27.7
Zn	g/t	35

Note: LECO – a carbon and sulfur assay instrument using the combustion infrared detection technique; CVAA – cold vapor atomic absorption; ICP-OES – inductively couple plasma-optical emission spectrometry

The initial commissioning run, PP-01, was carried out on September 8, 2014 and the final run, PP-22, was completed on October 31, 2014 with a total of 200 operating hours. A total of 22 pilot plant runs, PP-01 to PP-22, were completed. The flowsheet used for the pilot plant campaign consisted of the following circuits:

1. primary grinding
2. flash flotation
3. secondary grinding
4. rougher flotation
5. primary polish grinding and cleaner flotation
6. primary cleaner concentrate classification
7. separate secondary polish grinding and flotation of classification products.

The products from different internal and external streams were collected every hour and submitted for total carbon assays. The assay data were used to evaluate the metallurgical performance of the pilot plant and to make adjustments to improve the metallurgical results.

According to the test results and the observations of runs PP01 to PP07, some minor modifications were made to enhance the metallurgical performance of the circuit. This included a change to the classification arrangement of the first cleaner concentrate, and the addition of dewatering the finest size fraction ahead of the secondary cleaning circuit. The dewatering process helped to increase the pulp density in the secondary polishing mill treating the -250 mesh material, thus increasing polishing efficiency. In addition to the flowsheet modifications other process variables such as reagent dosages, air flowrates, and froth removal rates were optimized throughout the entire pilot plant campaign. The modified flowsheet used in pilot plant runs PP-08 to PP-22 is shown in Figure 13-2. In addition to the actual flowsheet, the graph also depicts the metering points of process instrumentation equipment such as power meter, airflow meter, wash water controller, pH meter, redox probe, and auto samplers.

In order to obtain a full circuit mass balance, a total of 11 circuit surveys were carried out when the pilot plant circuit appeared in steady state. The data collected from the surveys, including particle distribution analysis on various streams, was used to quantitatively evaluate the metallurgical performance of the pilot plant circuit. With the data reconciliation software Bilmat™, the overall mass balances were generated using the total carbon grades from all the survey samples.

The average particle size for the pilot plant feed, flash flotation feed, and graphite rougher feed are shown in Table 13-6.

Table 13-6: Average Particle Size of Feed Streams

Feed Streams	80% Passing (µm)
Head	17,548
Flash Flotation Feed	689
Rougher Flotation Feed	236

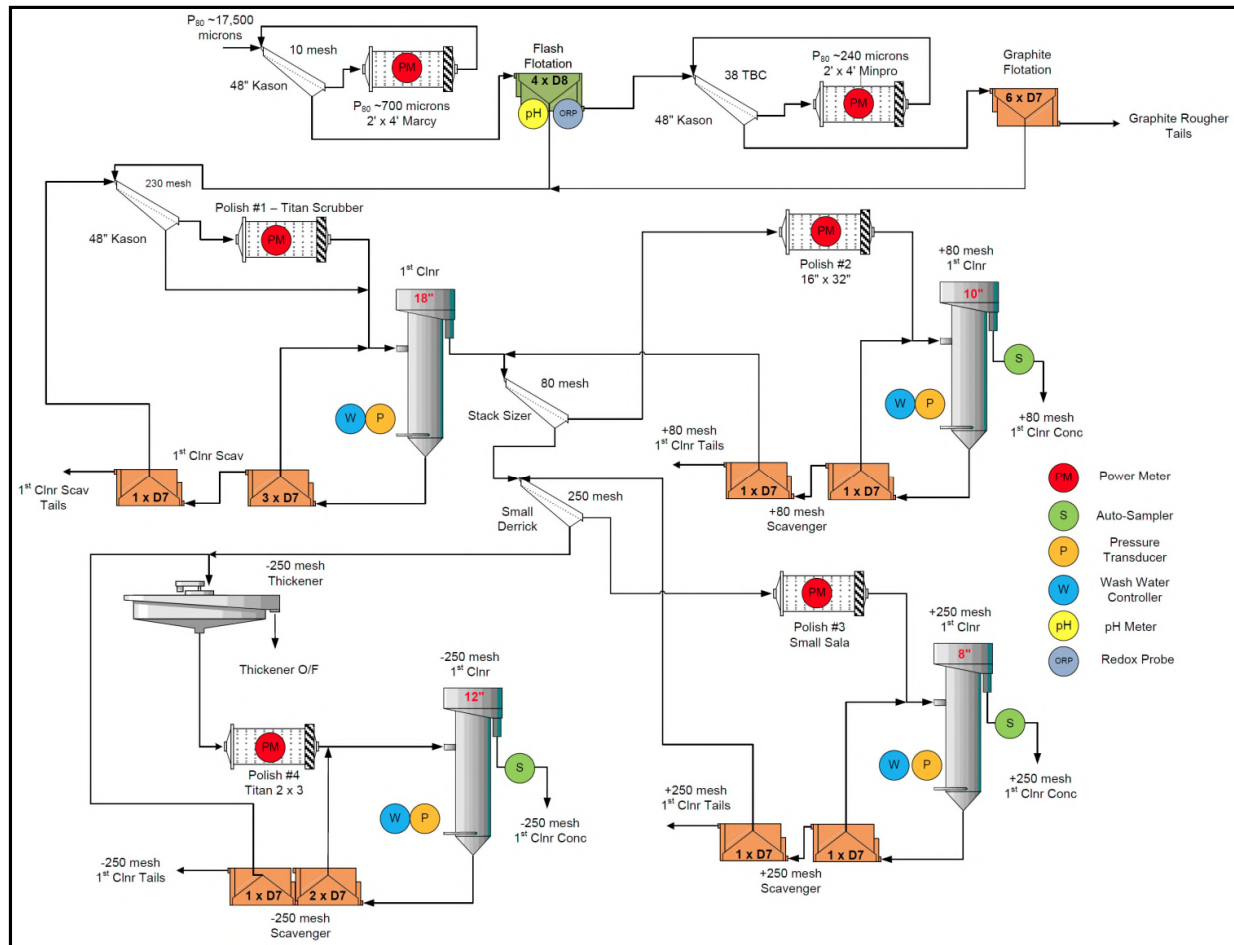

Figure 13-2: Flowsheet for Plant Runs from PP-08 to PP-22

The same reagent regime that was employed in the laboratory scale program was also chosen for the pilot plant, consisting of fuel oil #2 and MIBC. Figure 13-3 depicts the reagent consumption for 19 of the 22 pilot plant runs. The first two runs PP-01 and PP-02 were excluded as they were deemed mechanical commissioning runs. Based on the results of the pilot plant runs PP-15 to PP-22, SGS estimated that the optimized reagent dosages for both fuel oil and MIBC would be between 140 and 170 g/t.

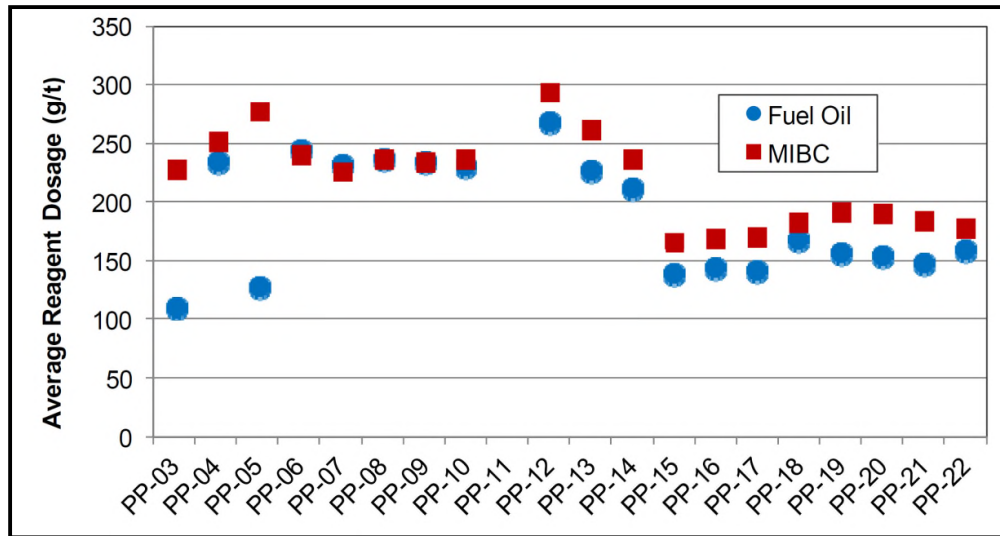

Figure 13-3: Reagent Consumption – Pilot Plant Runs

Mass balance results from the 11 circuit surveys indicate that the pilot plant produced an average final concentrate grade of 95.1% total carbon, ranging from 91.9 to 96.6% total carbon. The average carbon recovery was 84.0%, ranging from 74.5 to 92.5%. The average head grade for these pilot plant runs was 7.63% total carbon.

The total carbon grade of the combined concentrates versus the total carbon recovery into the combined concentrate of 10 circuit surveys is depicted in Figure 13-4. The survey results from the PP-20 run with a total carbon recovery of 58.3% were because the flash and rougher flotation conditions were too selective. For most projects and commodities, the recovery decreases as the concentrate grade increases. However, in the case of the Miller bulk sample that was processed in the pilot plant, high concentrate grades were maintained, even as the circuit carbon recoveries exceeded 90%. The plant surveys that were conducted at more selective flotation conditions were aimed to determine the maximum concentrate grade that can be achieved with the flotation circuit while accepting lower carbon recoveries. However, since more selective flotation conditions failed to further improve the concentrate grades, SGS recommended more aggressive operating conditions to maximize carbon recoveries while maintaining a high concentrate grade. It should be noted that the

lowest concentrate grade of 91.9% was obtained from the PP-05 run at the beginning of the pilot plant campaign when operating conditions were still being optimized.

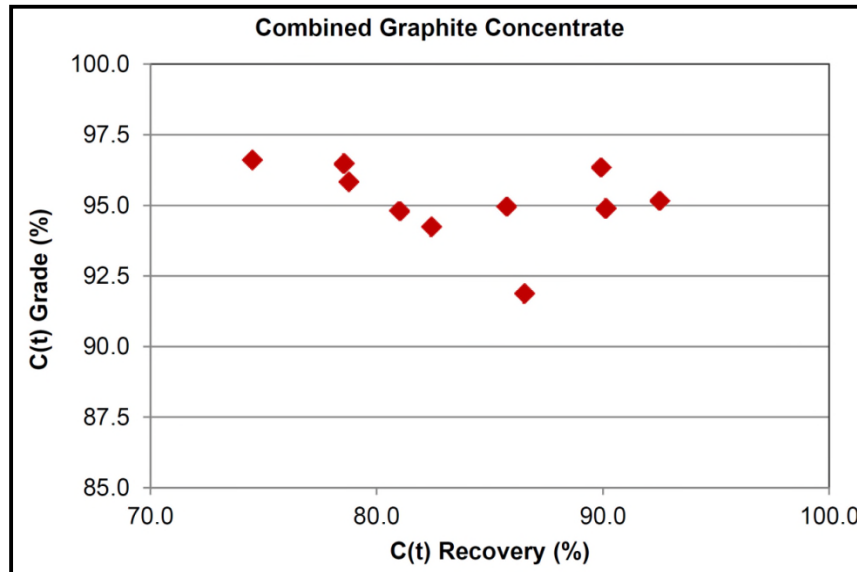

Figure 13-4: Carbon Recovery vs. Carbon Grade – Combined Graphite Concentrate

The combined graphite concentrates collected during each survey, starting from PP-08, were screened for particle size analysis, followed by a total carbon analysis on the various size fractions. The mass recovery into the various size fractions and the corresponding total carbon grades are depicted in Figure 13-5 and Figure 13-6, respectively. The particle size of the final concentrates from the surveys ranged between 80% passing 203 µm and 242 µm with an average particle size of 80% passing 217 µm.

The average grade of the coarser than 80 mesh size fraction was 98.2% total carbon at an average mass recovery of 31.3%, ranging between 26% and 42%. An average of 25.6% of the concentrate mass reported to the medium flake size fraction (smaller than 80 and larger than 150 mesh) with an average grade of 97.6% total carbon. The balance of 43.1% of the concentrate mass reported to the small flake fraction (finer than 150 mesh) with a grade of 92.6% total carbon.

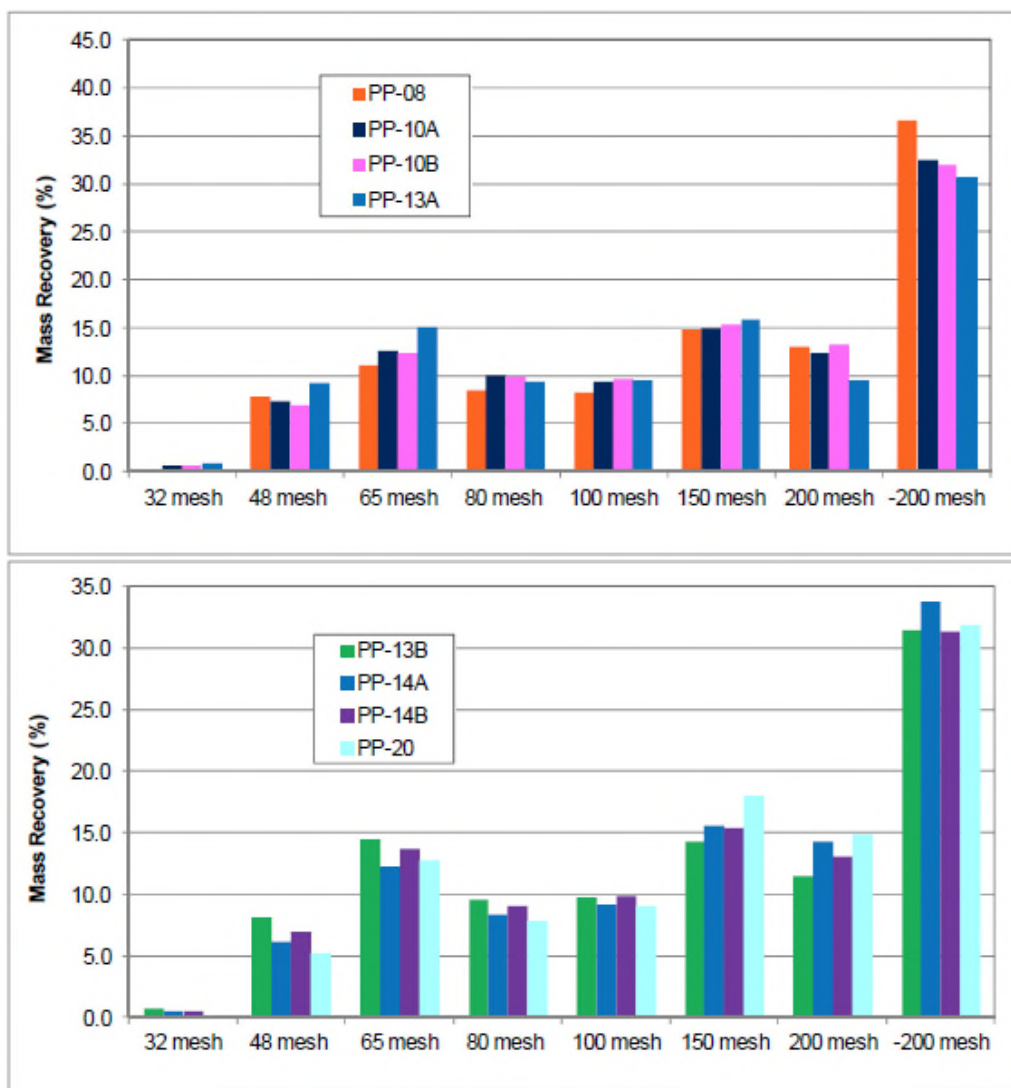

Figure 13-5: Final Concentrate Mass Distribution by Size Fraction

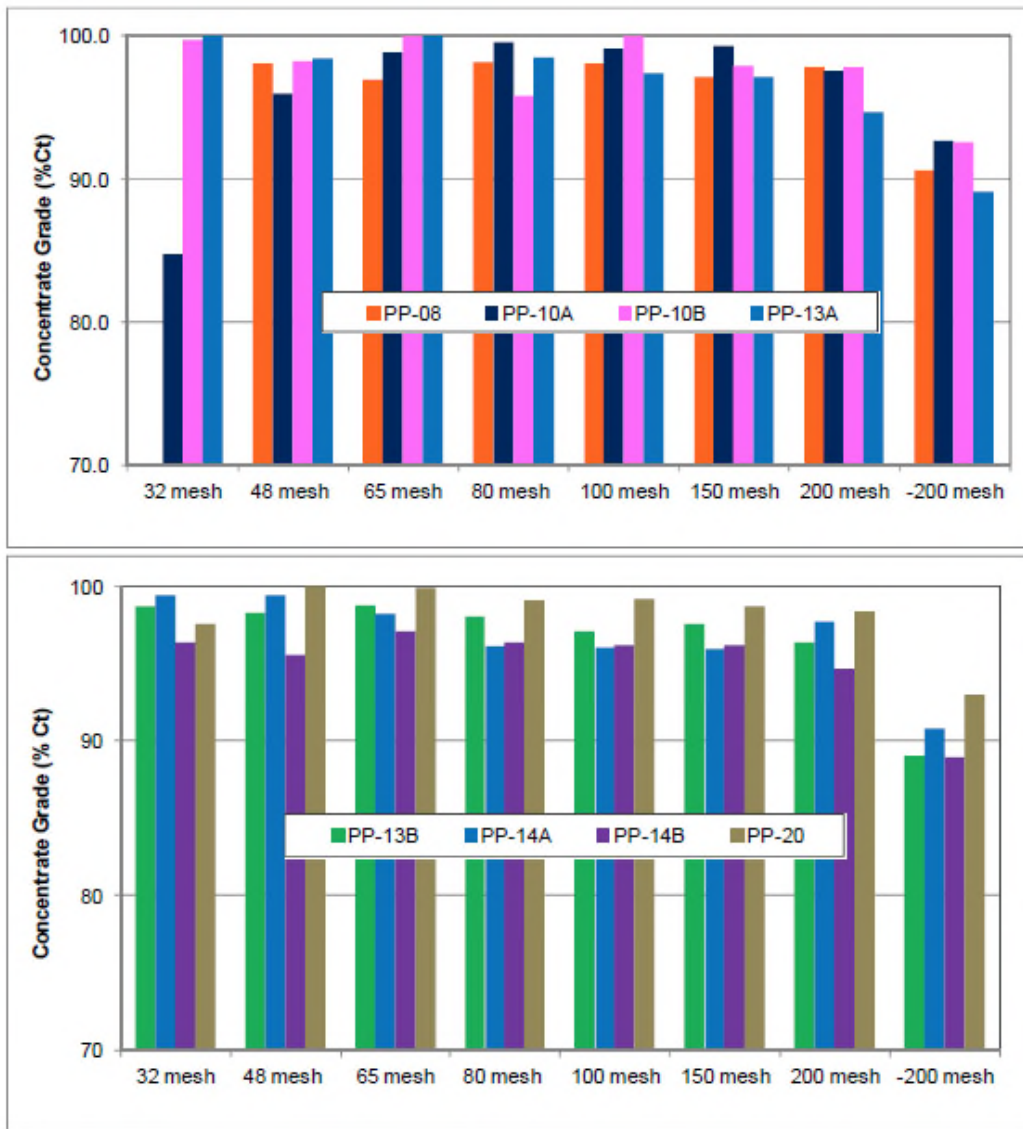

Figure 13-6: Final Concentrate Grades by Size Fraction

The average final concentrate size fraction analyses on eight survey samples are presented in Table 13-7. The average grade of the +80 mesh size fraction was 98.2% total carbon at an average mass recovery of 31.4% of the concentrate. An average of 25.6% of the concentrate mass reported to the medium flake size fraction (-80/+150 mesh) at an average grade of 97.6% total carbon. The concentrate mass reported to the small flakes fraction (-150 mesh) was 43.1% at an average grade of 92.6% total carbon.

Compared to the bench test results, it appears that the pilot plant produced a final concentrate with the finer particle size distribution. SGS indicated that these results suggest that the polishing conditions in the pilot plant operation may have been too aggressive. A decision to choose more aggressive polish grinding conditions was made in collaboration with the client to ensure concentrate targets were met. A full optimization of the circuit including polish grinding conditions would have taken significantly more time than the allotted 200 hours of operation.

Table 13-7: Total Carbon Assay on Different Size Fractions of Combined Concentrate from Eight Surveys

Size (mesh)	Average Mass Distribution (Wt%)	Average Grade (%C(t))
32	0.5	96.4
48	7.6	98.2
65	13.7	98.5
80	9.5	98.0
100	9.8	97.7
150	15.8	97.5
200	12.5	96.8
-200	30.6	90.9
Total (Calc)	100.0	95.6

The assay data of the grab samples collected from different pilot plant runs are summarized in Figure 13-7 illustrating the stability of the circuit in the second part of the campaign once flowsheet modifications were completed and process variables optimized.

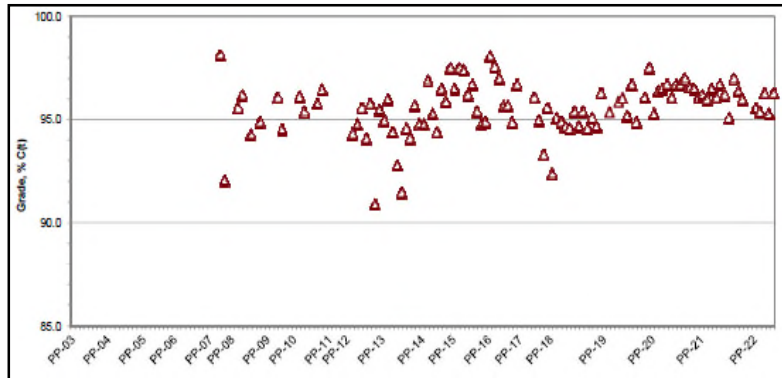

Combined Concentrate (All Fractions)

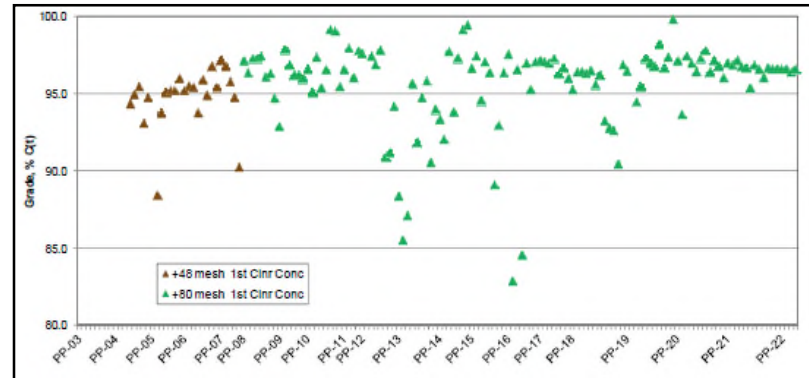

+48 mesh or +80 mesh

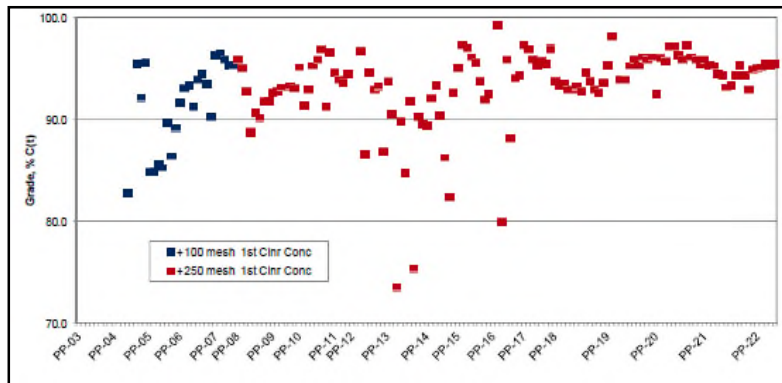

+100 mesh or +250 mesh

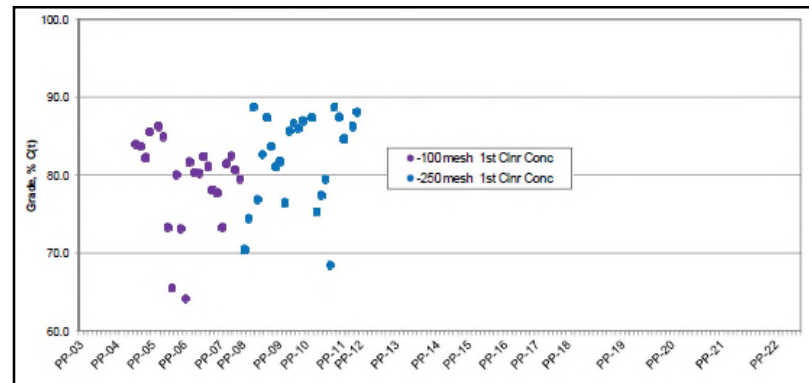

-100 mesh or -250 mesh

Figure 13-7: Final Cleaner Concentrate Grade Profiles from Grab Samples



The profiles of all grab and survey samples of the combined concentrate are depicted in Figure 13-8 (+48, +65, and +80 mesh size fractions) and Figure 13-9 (+100, +150, +200, and -200 mesh size fractions), respectively. The results show that consistently high concentrate grades were achieved in PP-04 immediately after mechanical commissioning of the circuit. All size fractions of 200 mesh and coarser consistently produced concentrate grades of 96% total carbon or higher with the exception of a few samples.

The combined concentrate from the PP-10B circuit survey that is highlighted with a red rectangle was screened and assayed by Leco before the size fractions were shipped directly to Evans Analytical in Syracuse, New York.

The as-received concentrates were subjected to a glow discharge mass spectrometry (GDMS) analysis to quantify the impurities in the different size fractions. The GDMS analysis is more suited for graphite concentrates with high carbon contents compared to the Leco as the measurement error of the GDMS analytical method is significantly smaller. It is able to quantify impurities at trace concentrations in high-purity inorganic solids and to quantify concentrations of up to 73 chemical elements in a single analysis. However, the required time and costs of the GDMS analysis limits its application to a small number of samples.

The results of both the Leco and GDMS are presented in Table 13-8. All analysed size fractions produced values of 99.38% total carbon or higher using GDMS analysis. As expected, the amount of impurities for the majority of graphite concentrates decreased as the size fractions increased. In contrast, the concentrate grades using Leco varied between 97.6% and 100% total carbon for the same size fractions. It should be noted that the GDMS results are conservative as any elements measured below their detection limit were assigned their detection limit as a value for impurity calculations.

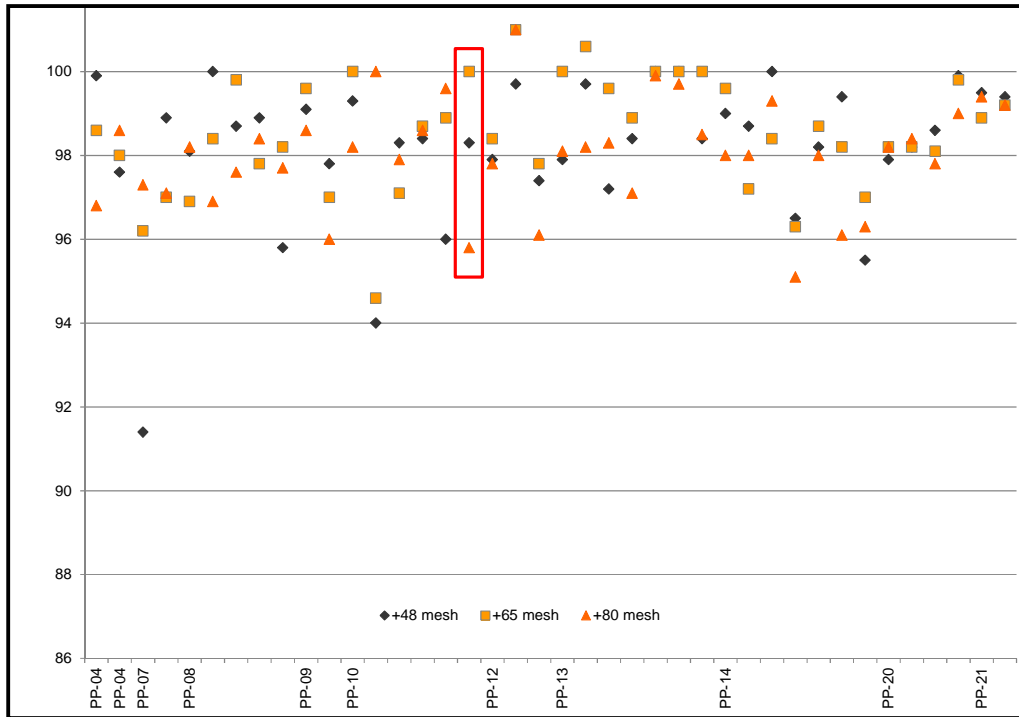

Figure 13-8: Combined Concentrate Grade Profile (+48, +65, and +80 mesh)

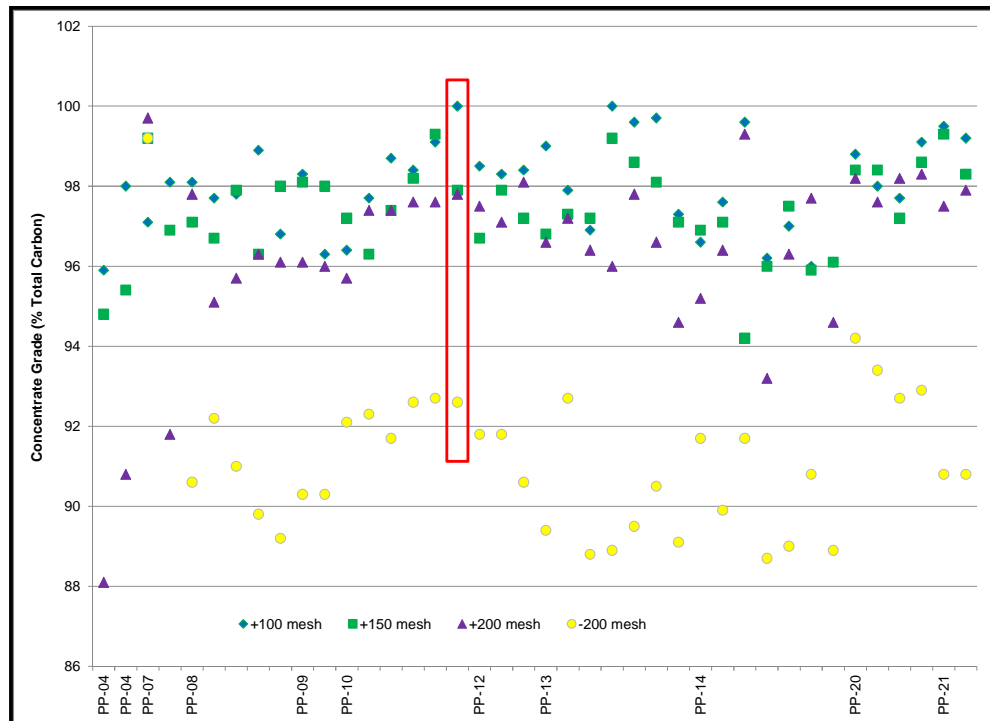

Figure 13-9: Combined Concentrate Grade Profile (+100, +150, -200 and +200 mesh)

Table 13-8: Results of Analysis of Combined Concentrate by Leco and GDMS

Size Fraction	Percentage of C(t) by Leco (%)	Percentage of (t) by GDMS (%)
+32 mesh	99.7	99.74
+48 mesh	98.3	99.73
+65 mesh	100	99.70
+80 mesh	97.6	99.63
+100 mesh	100	99.63
+150 mesh	97.9	99.52
+200 mesh	97.8	99.38
-200 mesh	92.6	Not Submitted

SGS derived following conclusions from the pilot plant campaign:

1. The grab samples revealed that the circuit reached a good stability shortly after the commissioning runs.
2. Circuit mass balances for runs PP-05 to PP-20 indicated that the plant produced a final concentrate with a grade ranging from 91.9 to 96.6% total carbon and a carbon recovery between 74.5 and 92.5%. The average head grade, final concentrate grade, recovery, and mass pull into concentrate were 7.63% total carbon, 95.1% total carbon, 84.0%, and 6.71%, respectively.
3. Screen analyses were conducted on eight survey samples of the combined concentrate during the PP-08 to PP-20 runs. The results indicated that the 80% passing particle size of the final concentrates ranged between 203 and 242 µm with an average 80% passing particle size of 217 µm. The average mass recovery as a proportion of total concentrate to the +80 mesh, -80 mesh to +150 mesh, and -150 mesh size fractions was 31.3%, 25.6%, and 43.1%, respectively. The average final concentrate graded 95.6% total carbon.
4. The average final concentrate grade derived from grab sample assays was 95.6% total carbon, which was consistent with the average grade from the survey samples at 95.1% total carbon. The average final concentrate grade of the pilot plant was also consistent with the concentrate grade obtained from bench test F1 at 94.4% total carbon. However, the recovery of the pilot plant was 6.5% higher than the bench test.

A review of the size fraction analyses of the pilot plant surveys reveals consistent results between the laboratory and the pilot plant testing and indicates that the majority of the impurities reported to the finer than 200 mesh size fraction. The enrichment of impurities in the finer size fractions is

characteristic for graphite deposits that impurities are entrained on the surface of the graphite flakes rather than intercalated within the graphite flake.

13.2.4 Concentrate Upgrading Tests

SGS conducted preliminary chemical upgrading tests on different graphite flotation concentrates to remove silicates and other impurities from the graphite flotation concentrate. Two methods were evaluated in the upgrading test:

1. Hydrofluoric acid leaching
2. Alkaline roasting followed by hydrofluoric acid leaching.

Preliminary thermal upgrading tests have also been conducted, including a preliminary test by a commercial processor of synthetic nuclear graphite using a proprietary thermal upgrading process on a randomly selected flotation concentrate sample produced from the pilot plant flotation trials at SGS.

13.2.4.1 Hydrometallurgical Upgrading

The +48 mesh graphite flotation concentrate that was generated in the first SGS flotation test F1 under SGS program 14185-001 on samples was treated by two different hydrometallurgical leaching methods. The objective was to determine the maximum concentrate grade that could be achieved with a flotation concentrate grading 94.4% total carbon and 93.5% graphitic carbon.

The hydrofluoric acid leaching test was conducted in two stages. The first stage involved mixing the feed sample with concentrated sulphuric acid (96% sulphuric acid) and water before concentrated hydrofluoric acid (48% hydrofluoric acid) was added to the mixture. The resulting slurry was heated to 90°C. After 300 minutes, water was added to the slurry. The slurry was stirred for an additional 60 minutes at 90°C. At the completion of the test, the slurry was filtered and the residue was thoroughly washed before the upgraded graphite was subjected to chemical analysis. The test conditions and test results are shown in Table 13-9 and Table 13-10, respectively. The purified concentrate was subjected to total carbon, graphitic carbon and double LOI analysis. Depending on the method, the results ranged between 99.2% graphitic carbon and 100% total carbon.

Table 13-9: Acid Leaching Test Conditions

Test ID	Feed Mass (g)	Particle Size (mesh)	HF (kg/t feed)	H ₂ SO ₄ , (kg/t feed)	Leach Retention Time (min)	Temperature (°C)
CC-T1	20	+48	334	864	360	90

Note: H₂SO₄ – sulphuric acid; HF – hydrofluoric acid

Table 13-10: Acid Leaching Test Results

C(t) (%)	C(g) (%)	LOI (%)	LOI @ 500 °C (%)	S (%)
Initial Graphite Grade				
94.4	93.5	95	n/a	0.03
Final Graphite Grade				
100	99.2	100.8	0.55	0.02

Note: LOI – loss on ignition

13.2.4.2 Alkaline Roasting + Hydrofluoric Acid Leaching

Another sample of the flotation concentrate which was subjected to the hydrofluoric acid leach described above, was also submitted to a 2-stage hydrometallurgical process consisting of an alkaline roast and hydrofluoric leach.

The alkaline roasting process consisted of a caustic bake followed by a dilute acid leaching. The caustic bake was conducted at a temperature of 400°C in a muffle furnace after the graphite concentrate was mixed with sodium hydroxide in solution. The baked mixture was then subjected to a water leach with deionized water followed by an acid leach with 10% sulphuric acid.

In the second processing stage, the remaining residue was further leached with a hydrofluoric acid/sulphuric acid mixture to remove any remaining impurities. The test conditions and results are shown in Table 13-11 and Table 13-12 respectively.

Table 13-11: Alkaline Roasting + Hydrofluoric Acid Leaching Test Conditions

Test ID	Feed Mass (g)	Particle Size (mesh)	HF (kg/t feed)	H ₂ SO ₄ (kg/t feed)	NaOH, (kg/t feed)	Retention Time (min)	Temperature (°C)
Alkaline Roast	30	+48	-	-	833	60	400
HF/H ₂ SO ₄ Leach	18	+48	370.7	960	-	360	90

Note: NaOH – sodium hydroxide

Table 13-12: Alkaline Roasting + Hydrofluoric Acid Leaching Test Results

C(t) (%)	C(g) (%)	LOI (%)	LOI @ 500 °C (%)
Initial Graphite Grade			
94.4	93.5	95	n/a
Product - Stage I: Alkaline Roast			
100	99.1	101	1.04
Product - Stage II: HF/H₂SO₄ Leach			
100	100	101	0.73

The two-stage caustic roasted/acid leached sample was submitted for full chemical analysis using GDMS analysis technology. Total measured elemental impurities were 246 ppm by weight, thus corresponding to a concentrate grade of approximately 99.97% total carbon.

In October 2014, SGS conducted another caustic bake test followed by dilute acid washing on a flotation concentrate sample collected from the pilot plant campaign PP-10. This is the same campaign that generated the flotation samples that were subjected to GDMS analysis. The purification work involved a three step process:

1. caustic baking at 400°C
2. washing of the baked product
3. dilute sulphuric acid leach and wash to neutralize any residual caustic soda and to remove impurities which are insoluble in caustic solution.

The flotation concentrates prior to purification and the caustic bake upgraded concentrate were screened into five particle size fractions. The five size fractions of the flotation concentrate and the purified graphite were subjected to purity assessment by GDMS. The analysis results are shown in Table 13-13.

The carbon purities of the flotation concentrate ranged between 98.43% for the -325 mesh product and 99.85% for the -48/+80 mesh size fraction. The Equivalent Boron Content (EBC) ranged between 1.351 ppm and 6.881 ppm. The carbon purities increased to 99.979% for the -325 mesh size fraction and were as high as 99.9942 for the -80/+150 mesh size fraction. The mass-weighted average carbon purity for the entire sample was 99.9925%. Using the GDMS results, the EBC value was estimated in a range from 0.720 to 0.824 ppm for the individual size fractions.

Table 13-13: Alkaline Roasted Concentrate Fraction Assay Results by GDMS

Particle Size (mesh)	Flotation Concentrate		Caustic Baked Flotation Concentrate	
	Carbon Purity ¹ (%)	EBC ² (ppm)	Carbon Purity ¹ (%)	EBC ² (ppm)
+48	99.79	1.550	99.9929	0.737
-48+80	99.85	1.351	99.9939	0.720
-80+150	99.77	1.411	99.9942	0.737
-150+325	99.54	2.141	99.9929	0.777
-325	98.43	6.881	99.979	0.824

Notes: ¹Carbon purity was calculated by difference, 100% minus (sum of all impurity concentrations (%)). Reported carbon purity values were rounded to two significant digits. Reported GDMS elemental contaminant concentrations when added to the reported carbon purities, may not add to 100%, due to rounding error. Only the actual concentration of the various elements is considered and not their oxide form.

²Equivalent Boron Content (EBC) of the graphite is calculated from the impurity concentrations obtained by GDMS, as defined in ASTM Method C1233-09, “Standard Practice for Determining Equivalent Boron Contents of Nuclear Materials”, in conjunction with ASTM Standard D7219-08, “Standard Specification for Isotropic and Near-isotropic Nuclear Graphites”, which lists the 16 elements of concern with respect to the EBC criterion. EBC is a means of estimating the potential for the impurities contained in the graphite to absorb neutrons when exposed to the controlled neutron flux within a nuclear reactor. Any impurities absorbing neutrons would adversely affect the rate and the control of the nuclear chain reaction. EBC is calculated as the sum of the EBC of each impurity, such that EBC (impurity) = (EBC factor for impurity) multiplied by (concentration of impurity (ppm)). Each EBC factor was obtained from Table 1 of ASTM Method C1233-09. Desired maximum EBC levels are typically between 1 and 3 ppm, depending on the specifications of end-users.

13.2.4.3 Thermal Upgrading

In 2013 EAG conducted a rapid thermal upgrading (RTU) test on a coarser than 65 mesh (210 µm) flotation concentrate produced by a bench-scale scoping level flotation program under SGS Project 14185-001. RTU is a method for quickly eliminating heat-labile impurities from a graphite sample by exposing the sample to high heat in the presence of an inert atmosphere. The thermal upgrading results by the RTU procedure show that the total impurity concentration can be reduced from 609 to 236 ppm, after a three minute heat treatment at a temperature of 2,300°C in a helium atmosphere.

The sample that was subjected to two-stage caustic roast/acid leaching described in section 13.2.4 was further treated by the rapid thermal upgrading conducted by EAG using the following conditions:

1. flowing helium atmosphere (100 mL/min)
2. temperature of 2,000 to 2,200°C
3. suration of 10 minutes.

Total measured impurities after heat treatment were less than 23 ppm, compared to greater than 246 ppm impurities by weight before heat treatment. More than 90% of the contaminants were removed from by rapid thermal upgrading, yielding carbon purity of 99.9978%.

Specific elements which were found in the pre-treated sample, but no longer detectable after thermal treatment included chromium, copper, iron, lead, magnesium, manganese, phosphorus, strontium, titanium, yttrium, zinc, and zirconium. In addition, aluminum, boron, calcium, chlorine, silicon, sodium, and sulphur were also reduced significantly (decreased by 50% or more).

In 2015, a randomly selected sample of the flotation concentrate (96.6% total carbon) produced from pilot plant flotation trial PP-10 conducted at SGS was treated by a proprietary thermal upgrading process employed by a commercial processor of synthetic nuclear graphite. After the concentrate sample was dried in an oven, the sample was thermally treated and upgraded to 99.9998% total carbon purity without a hydrometallurgical process. The thermal upgrading test was conducted at a temperature of approximately 2,200 to 2,300°C in an inert atmosphere.

The GDMS assay showed that ultra-trace amounts of six elemental contaminants were detected:

1. boron 100 ppb
2. sodium 400 ppb
3. copper 100 ppb
4. zinc 80 ppb
5. iron 90 ppb
6. silicon 1,700 ppb.

In 2015 a further thermal upgrading test was conducted using the proprietary thermal upgrading procedure by the commercial nuclear graphite processor. The concentrate used for the testing was blended from the concentrates generated from two bench-scale flotation tests under SGS program 14185-005 on a sample with a calculated head grade of 0.53% graphitic carbon. The average grade of the blended concentrate was approximately 96% total carbon. The upgrading tests yielded graphite of approximately 99.9995% total carbon purity, with an EBC value of 0.917 ppm, as determined by GDMS. The GDMS analysis revealed the ultra-trace concentrations of nine elements:

1. boron 300 ppb
2. sodium 500 ppb
3. aluminum 100 ppb
4. silicon 3,000 ppb
5. phosphorus 200 ppb
6. potassium 200 ppb
7. calcium 600 ppb
8. iron 90 ppb

9. tungsten 200 ppb.

Canada Carbon assumes that the contaminants identified following thermal treatment may associate with the hydrothermal matrix, rather than with the crystalline graphite itself, due to the high correlation between silicon content and all other measured elemental contaminants.

13.2.5 Other Graphite Characterization Tests

EAG also performed a laboratory characterization test on a Miller graphite sample provided by Canada Carbon to acquire a Raman spectrum. The crystallinity results were obtained using Raman spectroscopy, which is able to definitively determine the degree of crystallinity of certain materials, including graphite. Raman spectroscopy is the collection of light inelastically scattered by a material or compound. When a light of known wavelength strikes a material, the light is shifted according to the chemical functionalities of the material. The intensity of this shifted light depends on both molecular structure and macrostructure. As a result of these phenomena, the collection of the shifted light gives a Raman spectrum that can provide direct information regarding the molecular vibrations of the compound or material.

The crystallinity characterization was measured using a “LabRam” J-Y Spectrometer using an argon+ ion laser (514.5 nm wavelength) an 1,800 gr/mm grating. The Raman spectra were collected in the backscattering geometry (1,800) under an Olympus BX40 microscope.

The key spectral features collected were the G-band ($1,579\text{ cm}^{-1}$) and D-band ($1,350\text{ cm}^{-1}$), where the G-band is theoretically the only permitted band arising from a single crystal of graphite, and the D-band is a measure of the disorder within the crystal. The sharp, high-intensity, narrow-shouldered G-band peak strongly suggests that the sample is a single crystal of graphite. The D band was barely detected at $1,350\text{ cm}^{-1}$ which indicates extremely low disorder in that crystal. The spectrum acquired from a flake of the sample is shown in Figure 13-10. EAG indicated that the Raman spectrum clearly demonstrates that the graphite in the sample is very high quality single crystal graphite.

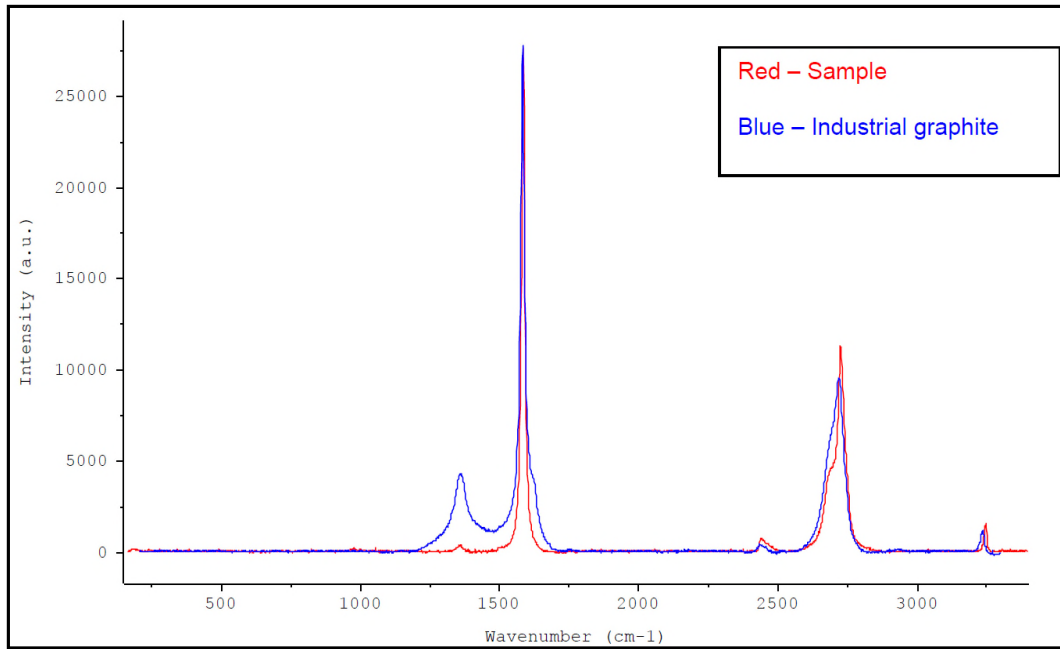
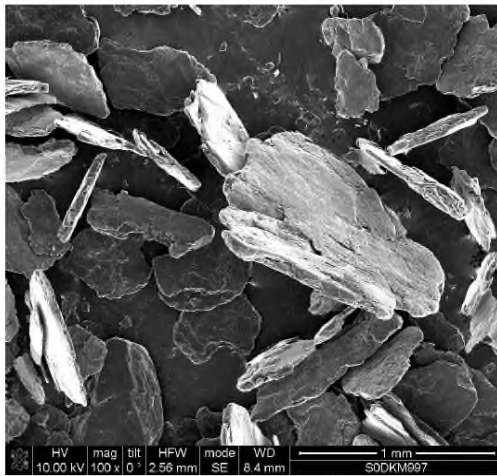
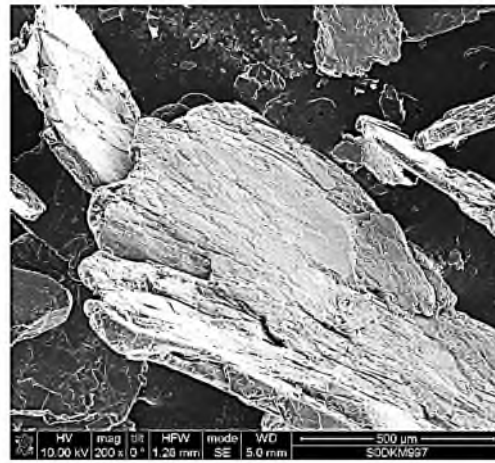

Figure 13-10: Raman Spectrum from a Flake of Miller Graphite

The graphite flakes were also studied by scanning electron microscope (SEM). The crystal images, including edge-on views of one graphite flake, are shown in Figure 13-11.



(100 X magnification) Large, platy graphite crystals, up to 1mm size, or more (+16 mesh).



(200 X magnification) Same super-jumbo crystal seen at higher magnification.

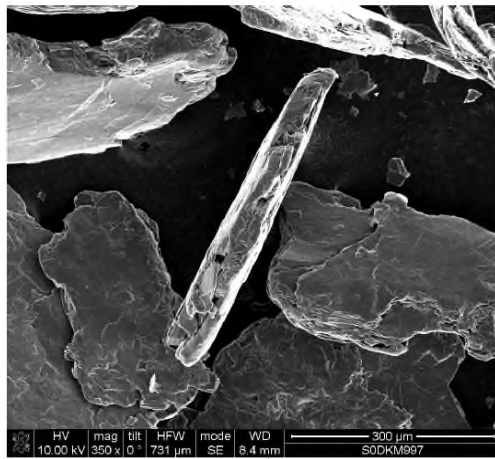

(350 X magnification) Edge view of a large graphite crystal.

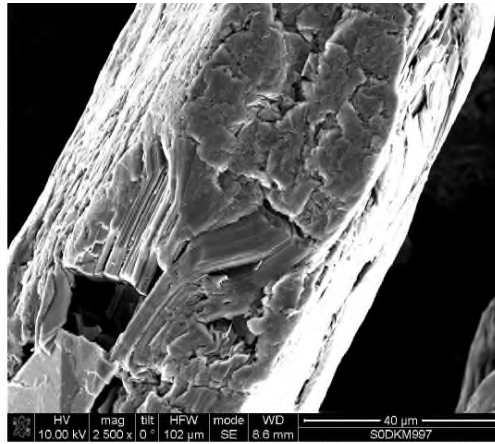

(2500 X magnification) Magnified view of the same crystal, revealing highly ordered layering (left side of image), with minor mechanical damage (right side of image).

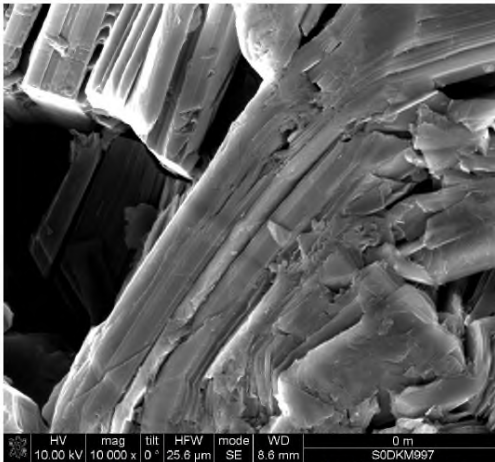

(10,000 X magnification) Higher magnification view of the same crystal, revealing sharp crystal edges.

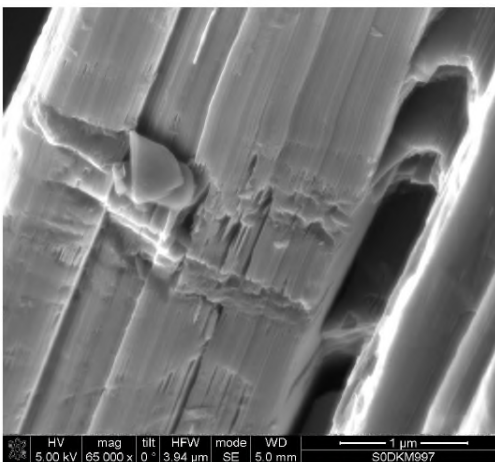

(65,000 X magnification) Still higher magnification view of the same crystal

Figure 13-11: Scanning Electron Microscope Images

13.3 Marble

Marble blocks were extracted and sent for assessments as architectural marble products. No detailed physical and chemical assessment results, such as moisture absorption, surface hardness, texture, colour, are available for the review.

13.4 Conclusions

The Miller graphite samples tested to-date responded well to traditional mineral processing technologies consisting of grinding and froth flotation. A simple reagent regime consisting of fuel oil #2 as the collector and MIBC as the frother proved effective to achieve high concentrate grades with good overall carbon recoveries.

Samples from the Miller graphite prospect submitted to metallurgical testing covered a wide range from 0.53% graphitic carbon to 61.2% graphitic carbon. Liberation and upgrading of the medium and large graphite flakes has been demonstrated consistently for all samples that have been evaluated in a series of laboratory scale and pilot scale metallurgical programs. The fine fractions of less than 200 mesh contain the largest amount of impurities and range between approximately 85% and 95% total carbon. Processing of the fines fraction was carried out using a conventional polishing grind approach with ½” ceramic media in a mill without lifters. While this type of polishing mill proved very effective for the medium and coarse flake sizes and resulted in concentrate grades of greater than 97% total carbon, the grinding conditions were not as effective for the fine fractions. Alternative grinding technologies were developed at SGS in Lakefield in 2015 to improve the liberation properties for fine graphite flakes and intercalated graphite. These grinding technologies are expected to be more suitable for the treatment of the Miller small graphite flakes as well.

Since polishing grind times are directly proportional to the amount of material feeding into the mill, a mining block model should be generated to establish an upper, lower, and average head grade for the mill feed. Any process optimization should be carried out using a Master composite that represents the average head grade to the mill and consideration of the nameplate capacity of the proposed plant to ensure proper equipment sizing.

While the relative measurement uncertainties of standard analytical methods for total carbon and graphitic carbon generally do not constitute a concern, the high concentrate grades obtained for medium and coarse graphite flakes in the Miller flotation concentrate as well as the purified product render these methods inaccurate. An alternative analytical method in the form of GDMS analysis has proven effective in quantifying the type and level of impurities associated with the graphite concentrates.

Preliminary chemical and thermal upgrading trials proved effective in removing the majority of impurities remaining after the flotation process to produce graphite concentrates meeting nuclear

graphite purity standards. While chemical upgrading was explored early in the project, thermal upgrading proved to be even more effective and led to a concentrate purity of 99.9998% in a 2015 upgrading trial. The six main remaining elemental impurities were detected at concentrations ranging between 80 and 1700 ppb, totalling 2,470 ppb. Similar results were obtained following thermal treatment of flotation concentrate obtained from bench scale processing of low grade disseminated graphite in marble.

The characterization of the potential marble source is preliminary in nature. Since marble is another industrial mineral that requires a close relationship between the producer and buyer, any further characterization work is expected to be carried out in close cooperation with the potential off-take partner(s).

14 MINERAL RESOURCES ESTIMATION

The Mineral Resource estimate was conducted using the CIM Definitions Standards for Mineral Resources in accordance with NI 43-101 Standards of Disclosure for Mineral Projects. Mineral Resources which are not mineral reserves do not have demonstrated economic viability. Inferred Mineral Resources are exclusive of the Measured and Indicated Resources. The Mineral Resource estimation work for the Project was conducted by Marc-Antoine Laporte, M.Sc., P.Geo. The 3D modelling, geostatistics, and grade interpolation of the block model was conducted using Genesis[®] software developed by SGS and Leapfrog[®]. The optimized pit shells and cut-off grade estimation were conducted by Tetra Tech. These pit shells are used to report Mineral Resources. The Mineral Resource estimation process was reviewed internally by Yann Camus, P.Eng., from SGS.

Although there is a potential for architectural marble on the property, only the graphitic carbon part of the resource is presented in this report. Given the results from the metallurgical testing (see Section 13) of low-grade graphite samples and the price of the commodity (see Section 19.0), disseminated and vein (pod) hosted graphite can be considered as Mineral Resources.

14.1 Database

The final database used for the Mineral Resource estimation was transmitted to SGS by Canada Carbon on October 14, 2022 in Microsoft[®] Access Geotic LOG format. The different validation and iteration steps are discussed in Section 12. The database comprised 32 drillholes and no channels with entries for:

- 130 down hole survey entries (including 32 that are collar surveys)
- 2,278 assay entries (95 additional intervals with sample numbers miss the grade)
- 453 lithology entries.

With the previous database that SGS possessed, the database comprised 213 drillholes and 135 channels (Figure 14-1) with entries for:

- 1,005 down hole survey entries (including 348 that are collar surveys)
- 11,885 assay entries (95 additional intervals with sample numbers and 118 without sample numbers miss the grade)
- 1,753 lithology entries.

The database was validated upon importation in Genesis[®], which enabled the correction of minor discrepancies between the table entries, surveys, and lithologies.

In 2018, 2 topographic surfaces were transferred to SGS by Canada Carbon, a local light detecting and ranging (LIDAR) and a regional digital elevation model (DEM). Both surfaces were merged to create a single surface with priority given to the LIDAR surface. The surface was processed and normalized in order to correct the distortion in the edges (Figure 14-2). In 2022, this surface was updated to fit with the drillholes. Also, one version of the topo was cut around the resource area to make the rendering easier during the resource modeling. A surface representing the contact between overburden and fresh rock was also updated using the lithological entries. Average overburden thickness is approximately 1.54 m with increasing thickness towards the southwest.

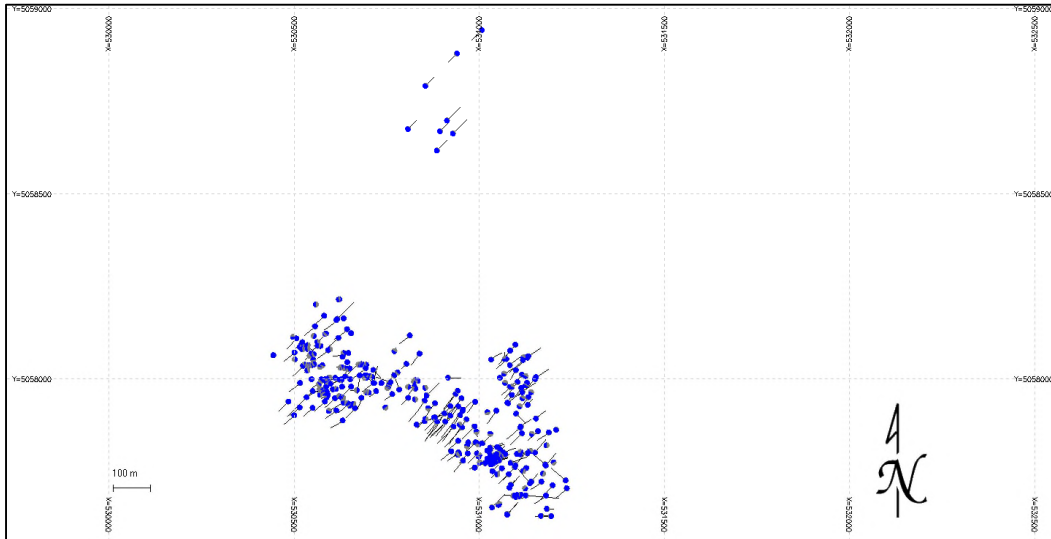

Figure 14-1: Drillhole Collar Positioning

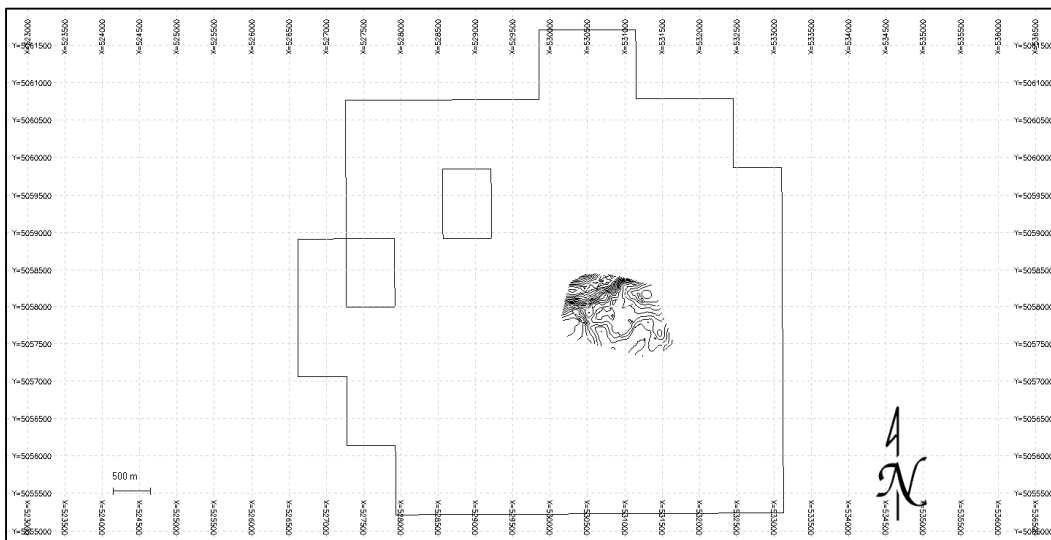

Figure 14-2: Topographic Surface where Resources are Modelled with Miller Property

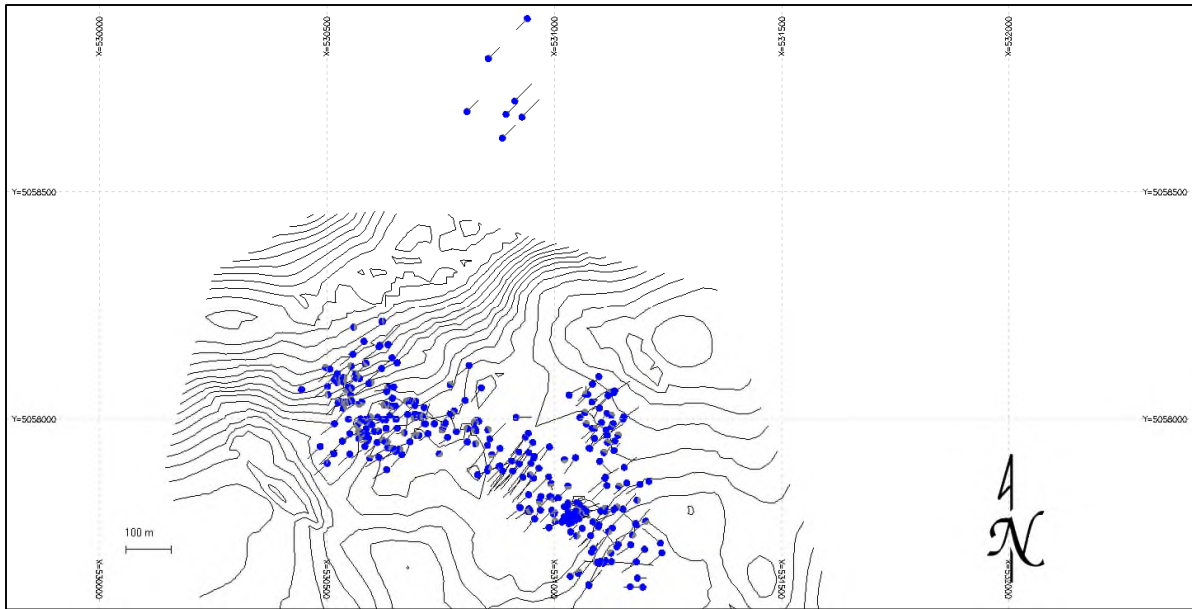

Figure 14-3 Topographic Surface where Resources are Modelled with Drillhole Collars

14.2 Geological Model

Since most of the mineralization is found in marbles or at the contact of marble and other rock units, the marble rock unit needed to be modelled. In order to take advantage of the available data, an effort was made to incorporate the geophysical survey results in the modelling process. A 3D inversion model of the airborne magnetic response survey was transmitted to SGS by Canada Carbon. The magnetic data was combined with the lithological observations made at the surface and in the drillholes to verify the possibility of using a magnetic threshold to map the marble rock unit (Figure 14-4). This enabled SGS to assign a modelled magnetic susceptibility value to each rock type in surface and drillhole data. The magnetic susceptibility values were then compared from one rock type to another and a limit of 0.006 on the International System of Units (SI) was established as the limit between non-magnetic rocks (marble and skarn; Figure 14-5) and magnetic rocks (arkose and paragneiss; Figure 14-5). This limit was modelled in the 3D inversion data, providing a probable contact surface between marbles (and skarns) and host rocks (Figure 14-6).

The marble unit was also modeled. The magnetic contact surface was then combined with the drilling database to model the extent of the marble unit, as identified by the level of information in the data. Two dimensional interpretations were conducted on each vertical section using the lithologies and magnetic contact surface in which only the marble was highlighted and all other lithologies were considered as non-marble (waste: Figure 14-7).

A 3D solid was then generated, corresponding to the marble rock unit interpretation, based on geophysical (magnetic) evidence and drillhole data (Figure 14-8). Extrapolation of the marble unit was

limited to 100 m beyond the last information point and interpolation of the solid (between two points of information) was limited at 100 m.

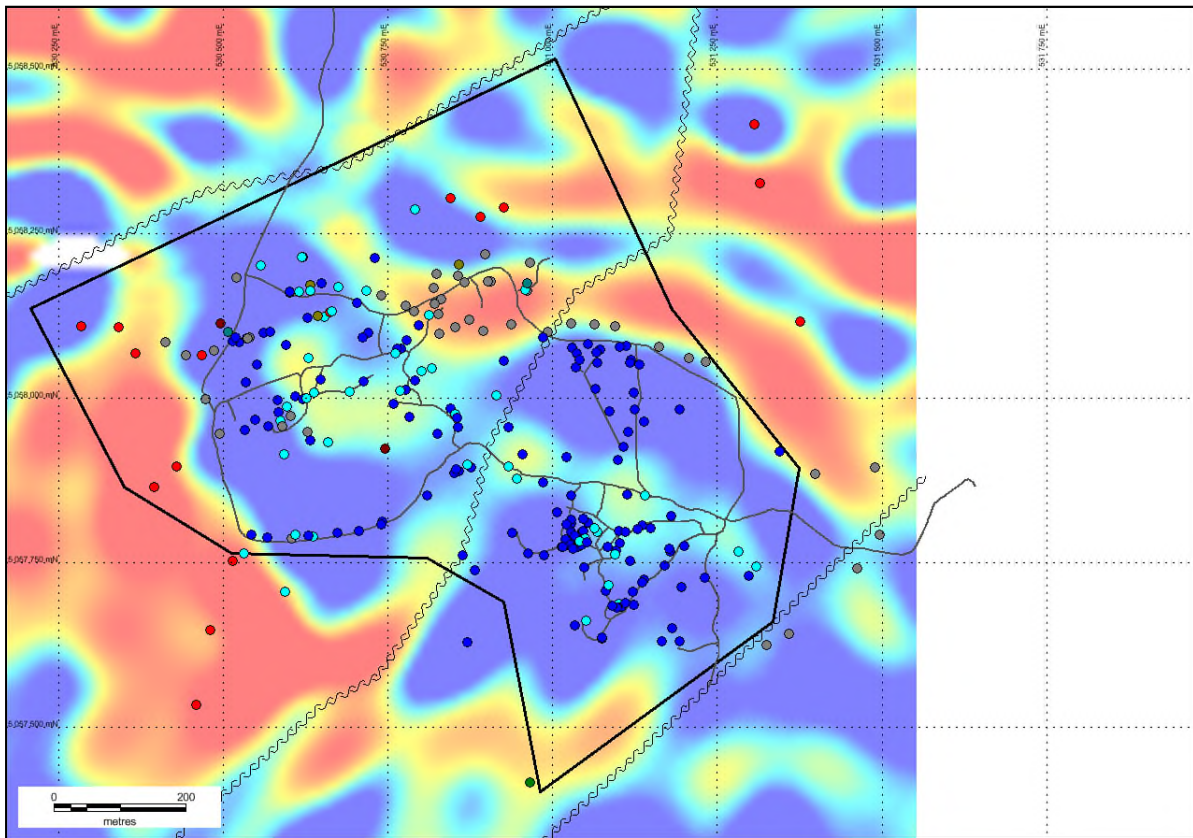

Figure 14-4: Magnetic Inversion with Surface Geology Points

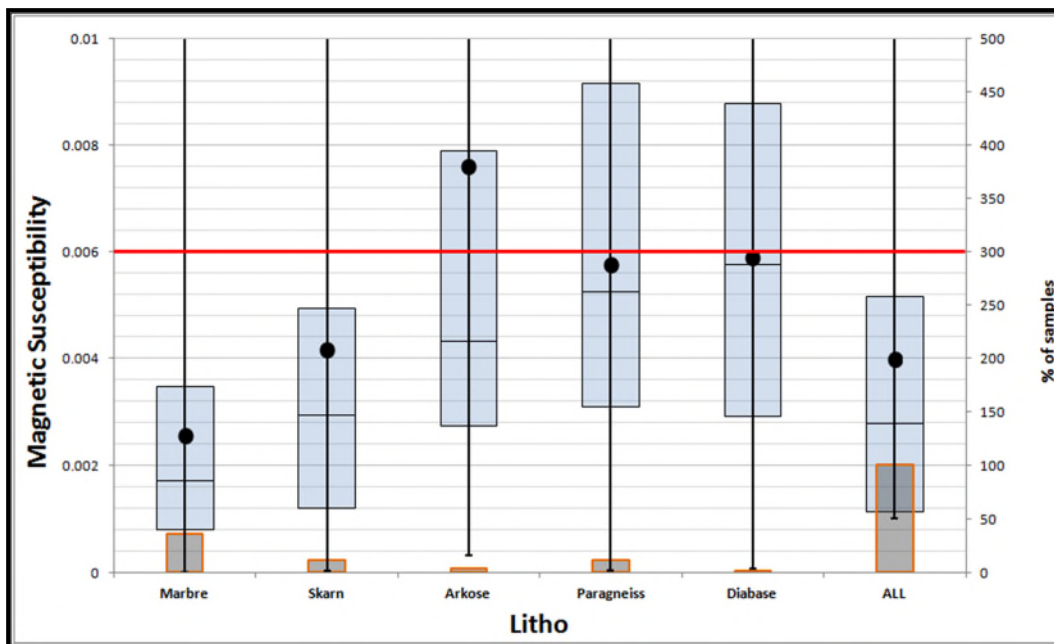

Figure 14-5: Magnetic Susceptibility of the Different Rock Types

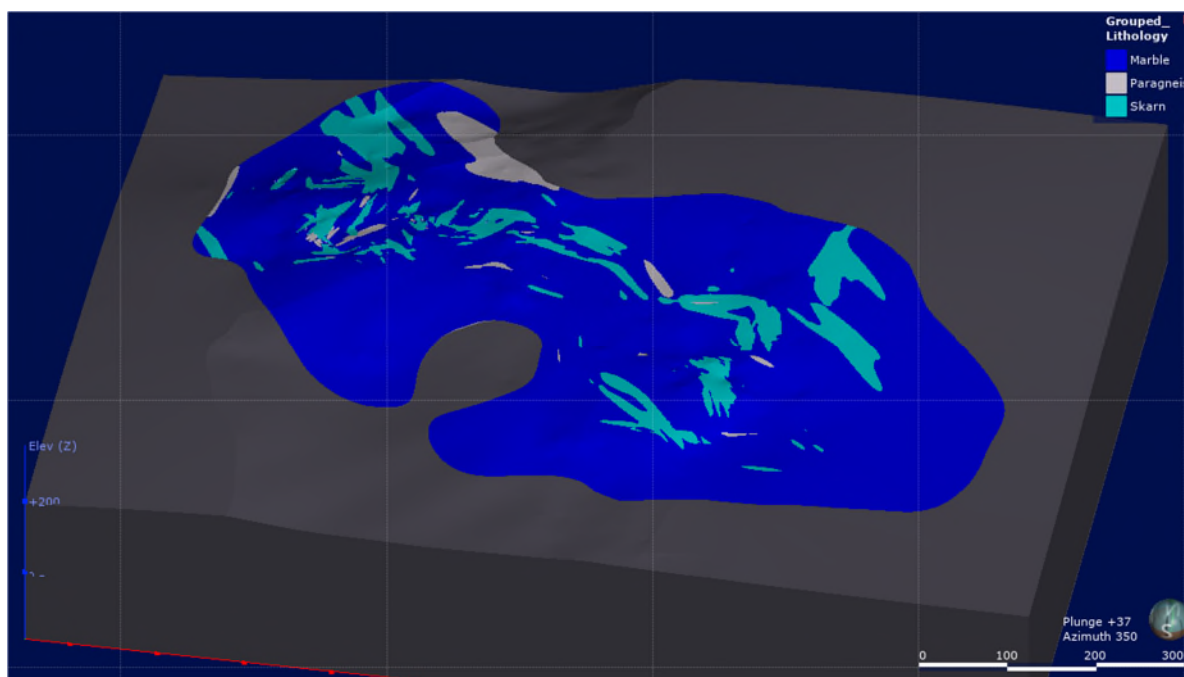

Figure 14-6: Modelled Contact between Marbles (+Skarn) and Arkose-Paragneiss

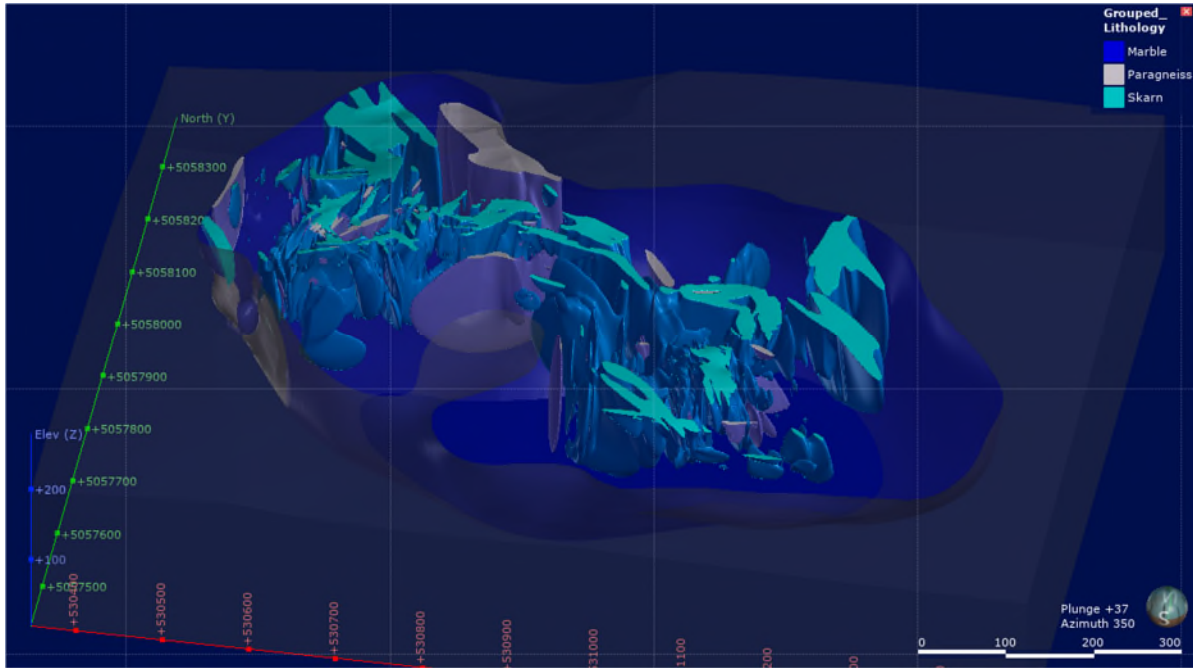

Figure 14-7: Sectional Interpretation of the Marble Unit

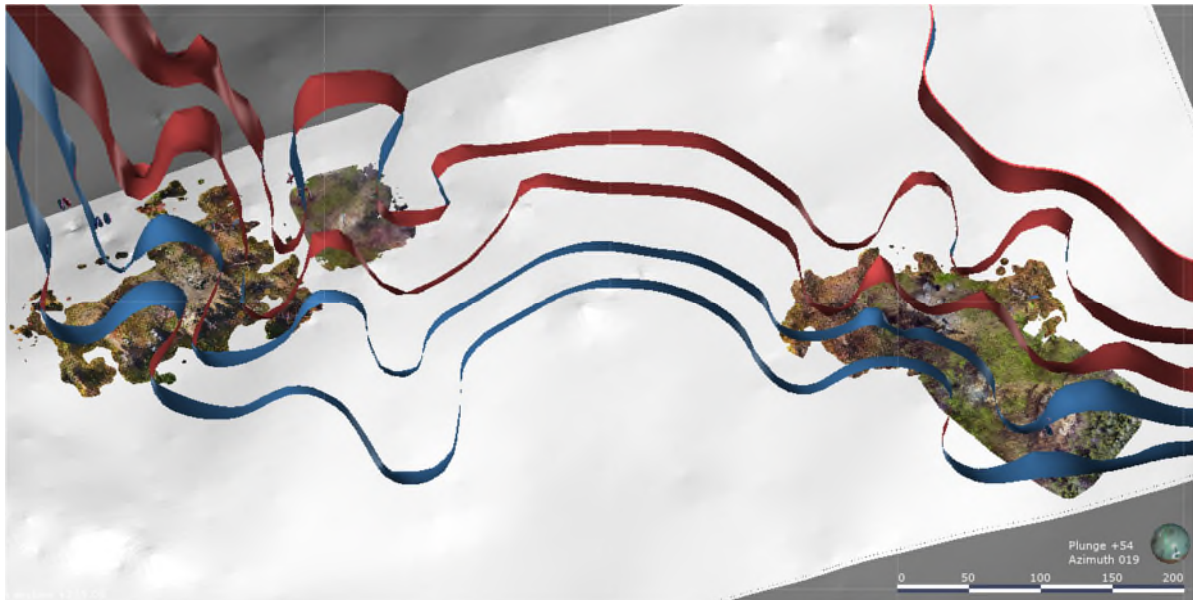

Figure 14-8: Interpretation of Key Paragneiss Bands within the Marble Unit.

14.3 Mineralized Intervals and Mineralized Solids

Mineralized intervals corresponding to an average grade of combined assays were generated on 10m intervals for the entire drill holes. Using the Geological model as constraints and the structural model to drive orientations and dip, the grades were modelled using Leapfrog’s interpolant tool. This created a series of grade shells for the 10m intervals from the drill holes. The solids were modelled to a maximum of 100 m from the last point of intersection and limited to the marble+skarn+paragneiss geological model. The contact between the host rock (gneiss) and the marble units was used as a hard boundary for the grade shells.

The modelling minimal grade was established in order to limit the amount of waste material included in the mineralized solids and from the graphite values observed in the geological model (Figure 14-9). In the event that a single hole in the middle of a geological envelope was lower than the minimal modelling grade, the hole was still integrated in the solids and is considered as internal waste. The 0.45% Cg grade shell was chosen to represent the limit of the resources block model (Figure 14-12).

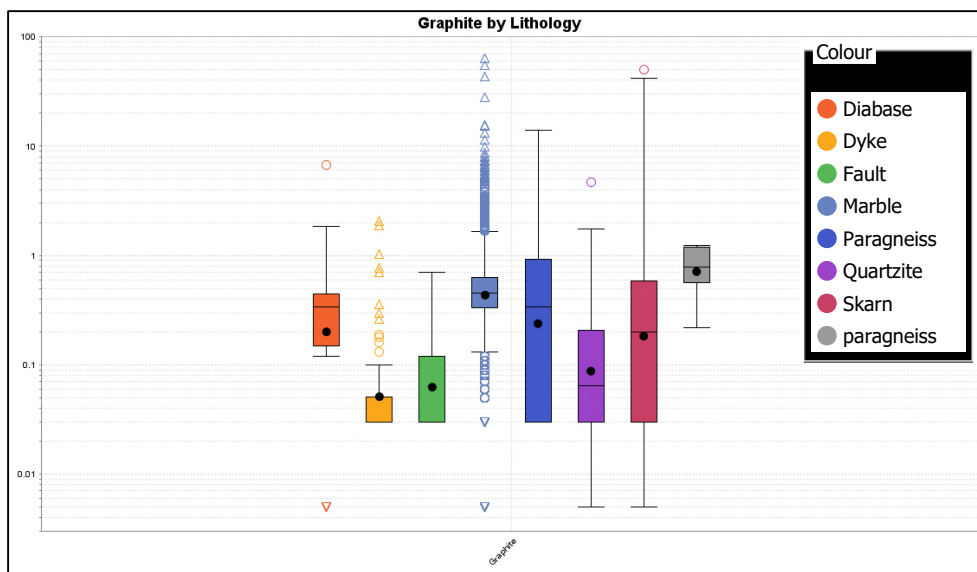

Figure 14-9: Graphitic Carbon Value Distribution for all Rock Types

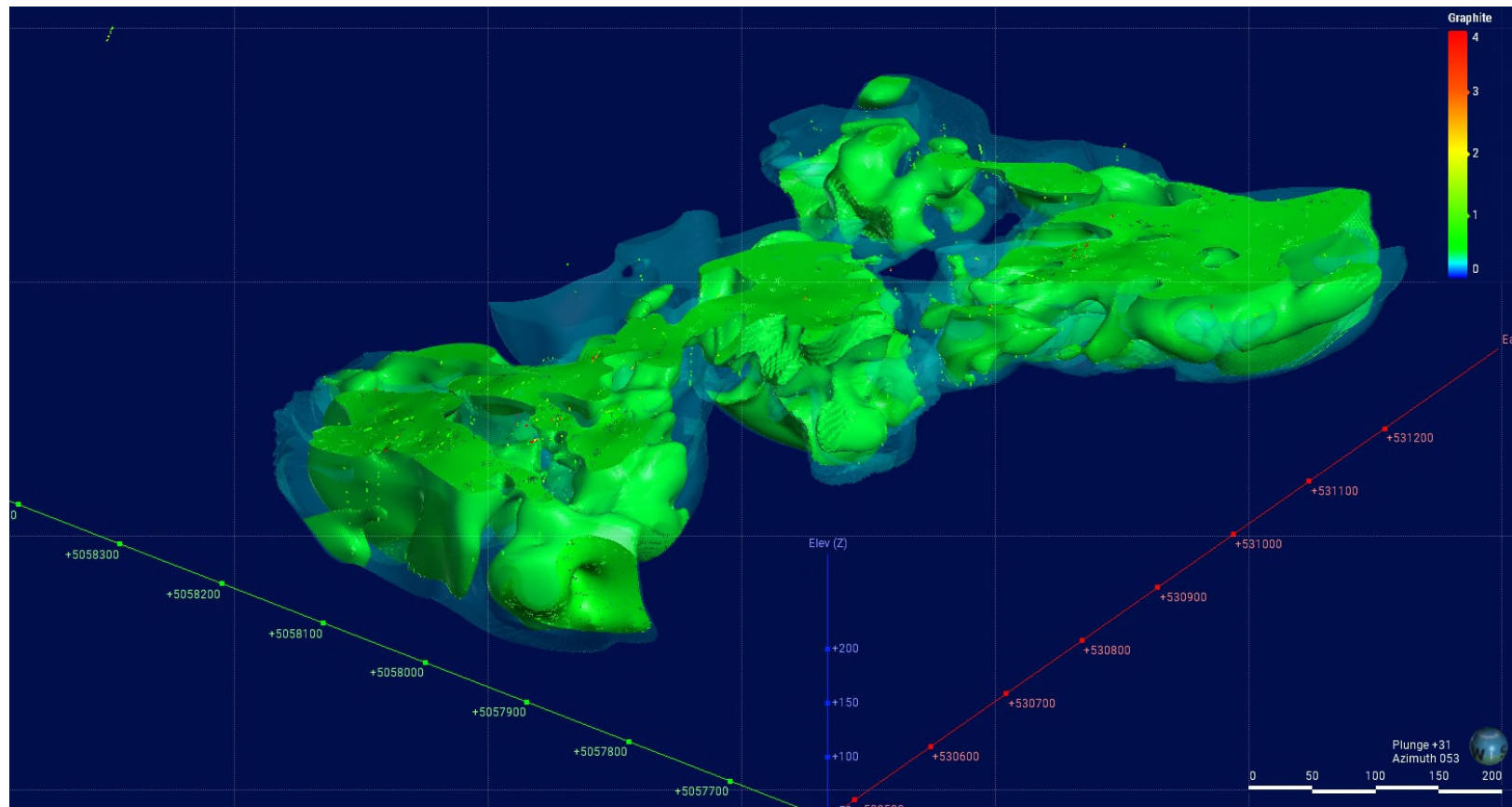

Figure 14-10: 3D Isocontours Model of the Graphite Mineralization

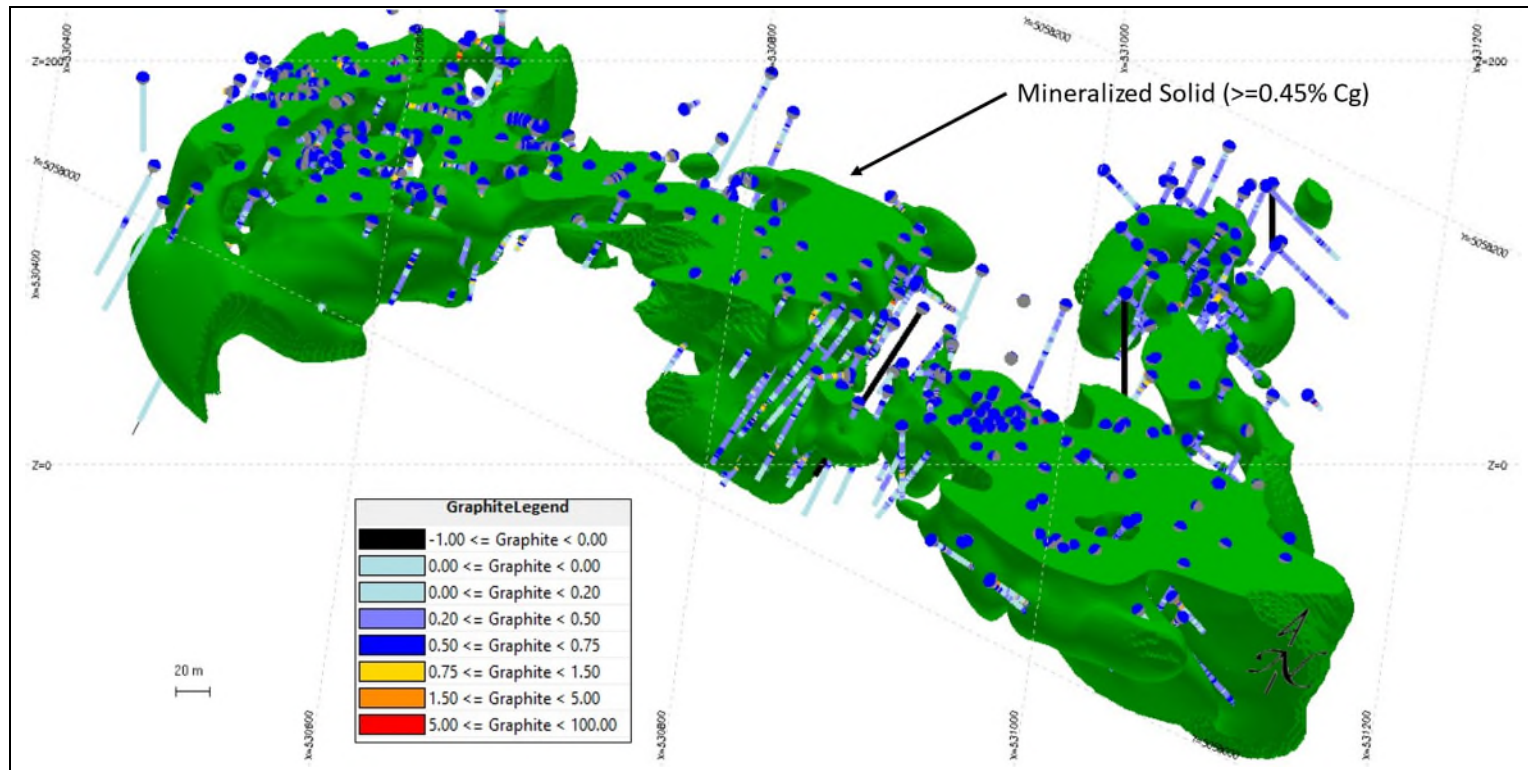

Figure 14-11: Mineralized Solid for Graphite

14.4 Compositing of Assays

14.4.1 Graphite Mineralization

The assays present inside the limits of the mineralized intervals were re-divided in equal length composites of 1.5 m, which represent the largest and second most common assay length in the database (Figure 14-12). They also represent a proper size compared to the selected block size (see below). These composites will be used to interpolate the block values. Composites were created at “around” 1.5 m length in order to not leave any remainders. Assay gaps inside the solids were replaced with composites with values of 0% graphitic carbon. A total of 4,384 composites were generated. (Figure 14-13). Only core inside the mineralized volumes were composited.

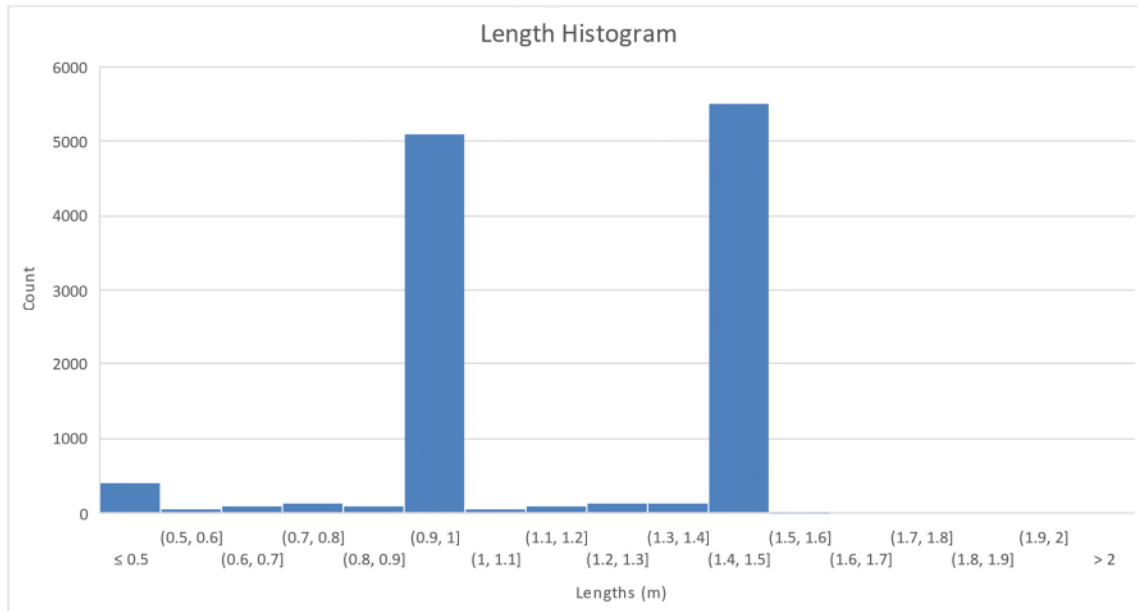

Figure 14-12: Assays Length Statistics

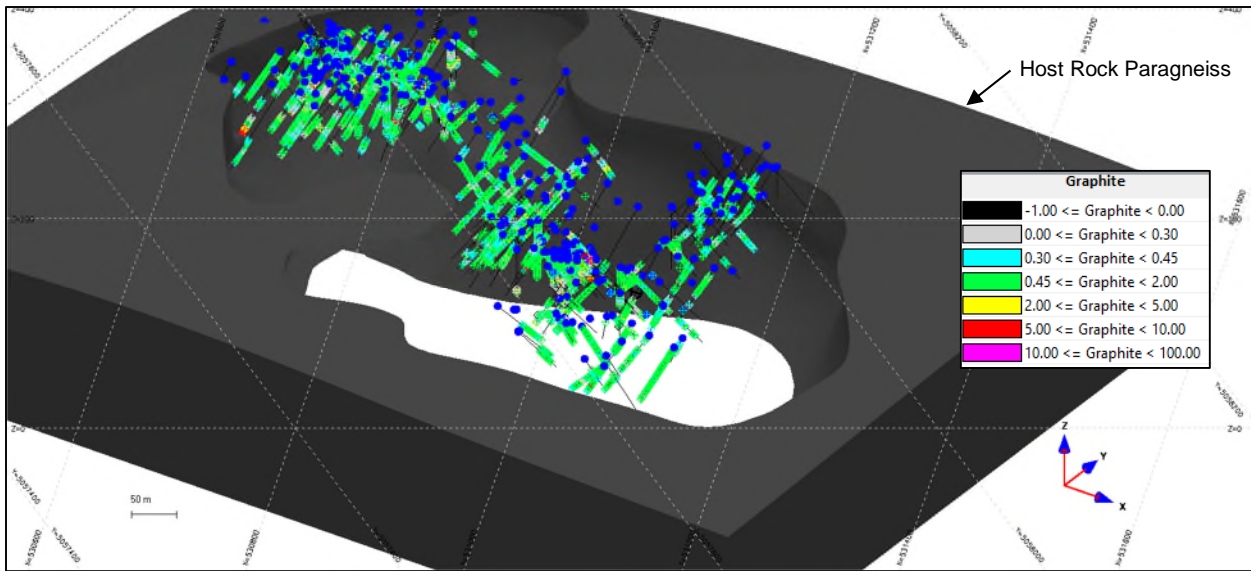

Figure 14-13: Graphite Composite set with paragneiss host rock

14.5 Geostatistics and Variography

In order to interpolate the different potential mineral resources, the composites were independently analyzed using standard statistic tools and variography. These steps allow for validation of the compositing process and mineralized solids generation. The mathematical models derived from the variograms will be used to interpolate the blocks using Ordinary Kriging and Indicator Kriging. Note that the 2021 drilling added only 17% of new composites so the variography was kept as for the previous estimation. This amount of data should not have a great influence on the variography and especially on the estimation of the resources. All other parts (statistics and histograms) are based on the final set of composites used for the resource estimation.

The composites corresponding to the graphite mineralization have an average value of 0.81% graphitic carbon (Table 14-1). The distribution of the values outlines three different populations within the graphite mineralization (Figure 14-14): 1) a population corresponding to the local integration of waste material in the solids and missing assay intervals within the solids; 2) a population representing the majority of the assay value, which can be considered as a disseminated low grade graphite mineralization; and, 3) a high-grade population representing the discontinuous veins and pods of graphite observed throughout the Miller Property.

The presence of the high-grade pods would be lost if conventional interpolation is used, since they only represent 4.4% of the population. A two-stage interpolation using indicators and high-grade probability model was used for resources estimation in order to present a more realistic model without exaggerated dilution and smoothing.

In order to proceed with this type of interpolation, the composite population needed to be divided between low grade and high grade, with a proper limit between both. The high-grade population was separated from the low-grade population using a process comparable to grade capping, in which the “break” in the frequency distribution is considered the limit between the low grade and high grade (Figure 14-16). This process was validated using a histogram modelling technique which establishes the limit between the two populations at 2% graphitic carbon (Figure 14-16).

Three new variables were then added to the composite set. The “GraphiteLG” variable corresponds with all the composites capped at a value of 2% graphitic carbon. The “GraphiteHG” contains all the composites uncapped and finally the “Indicator” variable contains “0” if the original graphite value is below 2% graphitic carbon and “1” if the original graphite value is equal or greater than 2% graphitic carbon.

Table 14-1: General Statistics of the Graphite Composites

Element	Count	Average	Minimum	Maximum	Standard Deviation	Variance	Coefficient of Variation
Graphite (%)	4,384	0.81	0.00	34.85	1.20	1.43	1.48
GraphiteLG (%)	4,384	0.70	0.00	2.00	0.44	0.20	0.63
GraphiteHG (%)	4,384	0.81	0.00	34.85	1.20	1.43	1.48
Indicator	4,384	0.04	0.00	1.00	0.21	0.04	4.65

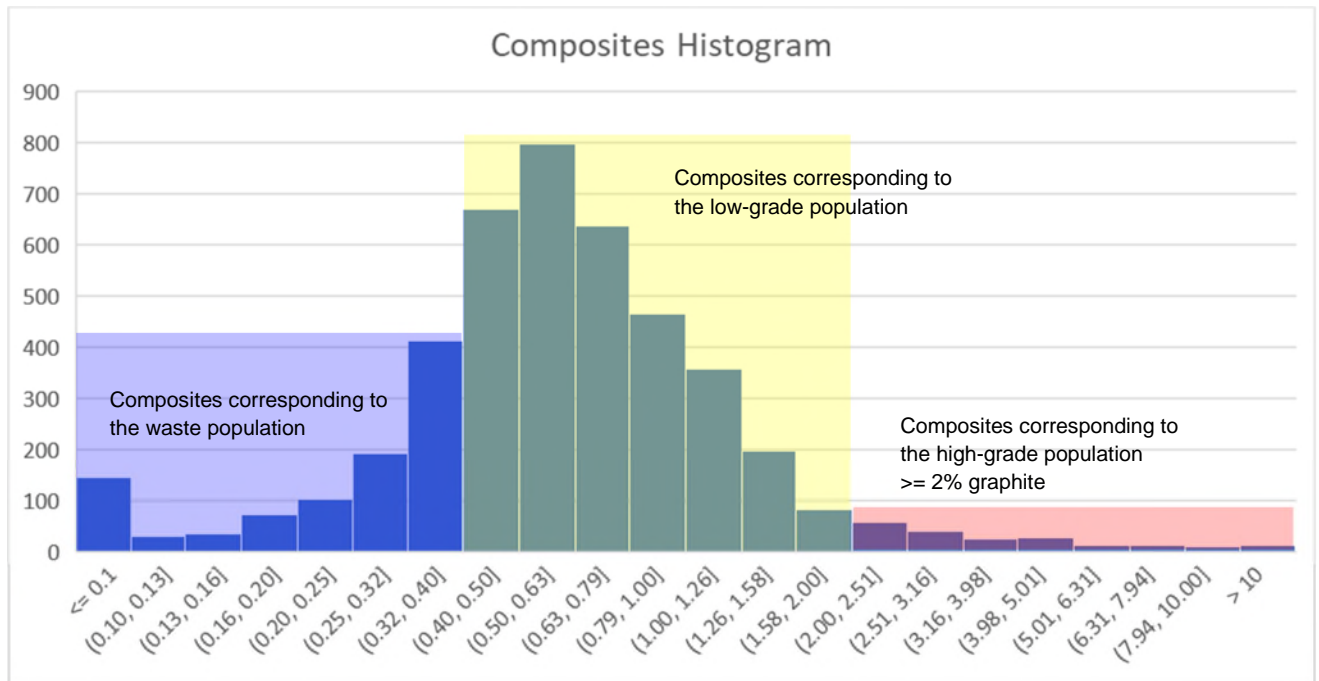

Figure 14-14: Statistical Distribution of Graphite Values

14.5.1.1 GraphiteLG Variable

This part was kept as is from the previous technical report. The GraphiteLG variable shows a skewed distribution towards the low values (Figure 14-17) with a mean value of 0.74% graphitic carbon (Table 14-1). The composites were used to generate a variogram with directions aligned along the strike of the deposit and 45° across the deposit in both northeast and southwest directions (Figure 14-17). The average variogram was also generated using mostly pairs along the same drillhole (Figure 14-17). The nugget effect is limited to 10%, due to the relatively low variance generated by capping of the high-grade population at 2% graphitic carbon. The major direction of continuity dips at -45° towards the southwest along the strike, which has a sill at 0.6 for a range of 0 m and a maximum range of 15 m (Figure 14-17). The other directions show relatively low continuity with 60% of the sill with a range of 0 m and a maximum range of 45 m (Figure 14-17). The model of the variogram is given by the following equation:

$$\text{Gamma} = N(0.1) + S(0.6, 15/7/7, 0/45/0) + S(0.3, 65/25/25, 0/45/0)$$

The variogram maximal range is smaller than the largest extrapolation and interpolation distance of the mineralized solid.

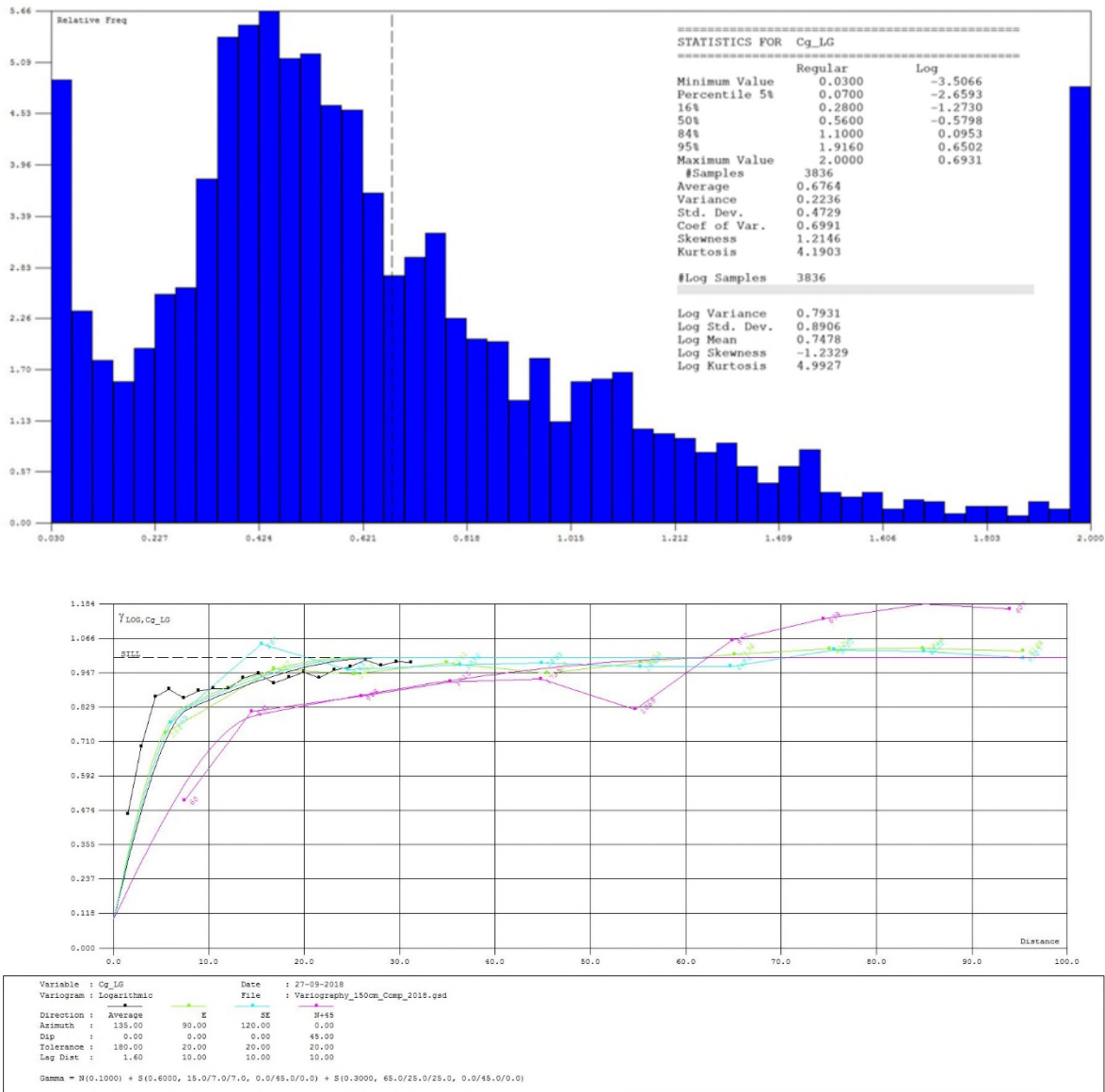

Figure 14-15: GraphiteLG Statistics and Variographic Model

14.5.1.2 GraphiteHG Variable

This part was kept as is from the previous technical report. The GraphiteHG variable shows a skewed distribution towards the low values (Figure 14-18) with a mean value of 0.81% graphitic carbon (Table 14-1). The composites were used to generate a variogram with directions aligned along the strike of the deposit and 45° across the deposit in both northeast and southwest directions (Figure 14-18). The average variogram was also generated using mostly pairs along the same drillhole (Figure 14-18). The

nugget effect is of 15%, which can be explained by the relatively low geological continuities of the high-grade veins and pods. The variographic model is isotropic with 85% of the sill at a range of 5 m and a maximum range of 25 m (Figure 14-18). The model of the variogram is given by the following equation:

$$\text{Gamma} = N (0.15) + S (0.65, 17/8/8, 0/45/0) + S (0.2, 70/25/25, 0/45/0)$$

The relatively low range of the variographic model might be due to low number of composites used (183), but also dictates low interpolation distances for the GraphiteHG variable, which is consistent with the geological observation of discontinuous pods and veins.

14.5.1.3 Indicator Variable

This part was kept as is from the previous technical report. The Indicator variable shows a skewed distribution towards the 0 values (Figure 14-17) with a mean value of 0.07 (Table 14-1); which is consistent with the majority of the graphite mineralization comprising low grade values. The composites were used to generate a variogram with directions aligned along the strike of the deposit and 45° across the deposit in both northeast and southwest directions (Figure 14-17). The average variogram was also generated using mostly pairs along the same drill hole (Figure 14-17). The nugget effect is limited to 40%, due to the relatively low variance generated by the high number of 0's in the values. The major direction of continuity is at -45° towards the southwest, which has a sill at 0.4 for a range of 0 m and a maximum range of 15 m (Figure 14-17). The other directions show relatively low continuity with 75% of the sill with a range of 0 m and 30 m (Figure 14-17). The model of the variogram is given by the following equation:

$$\text{Gamma} = N (0.4) + S (0.25, 10/10/10, 0/0/0) + S (0.35, 30/30/30, 0/0/0)$$

The variogram maximal range is smaller than the largest extrapolation and interpolation distance of the mineralized solid.

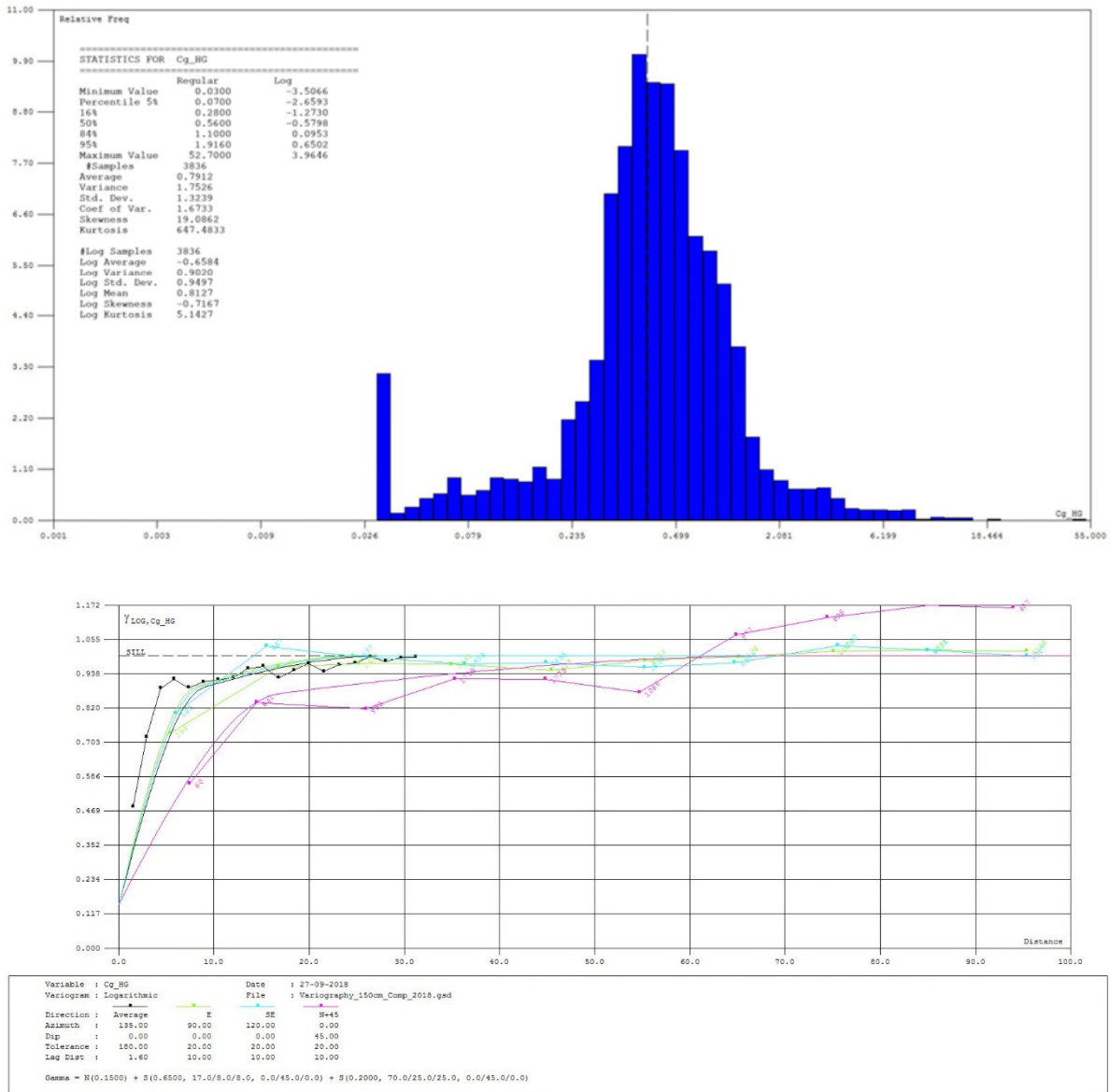

Figure 14-16: Graphite HG Statistics and Variographic Model

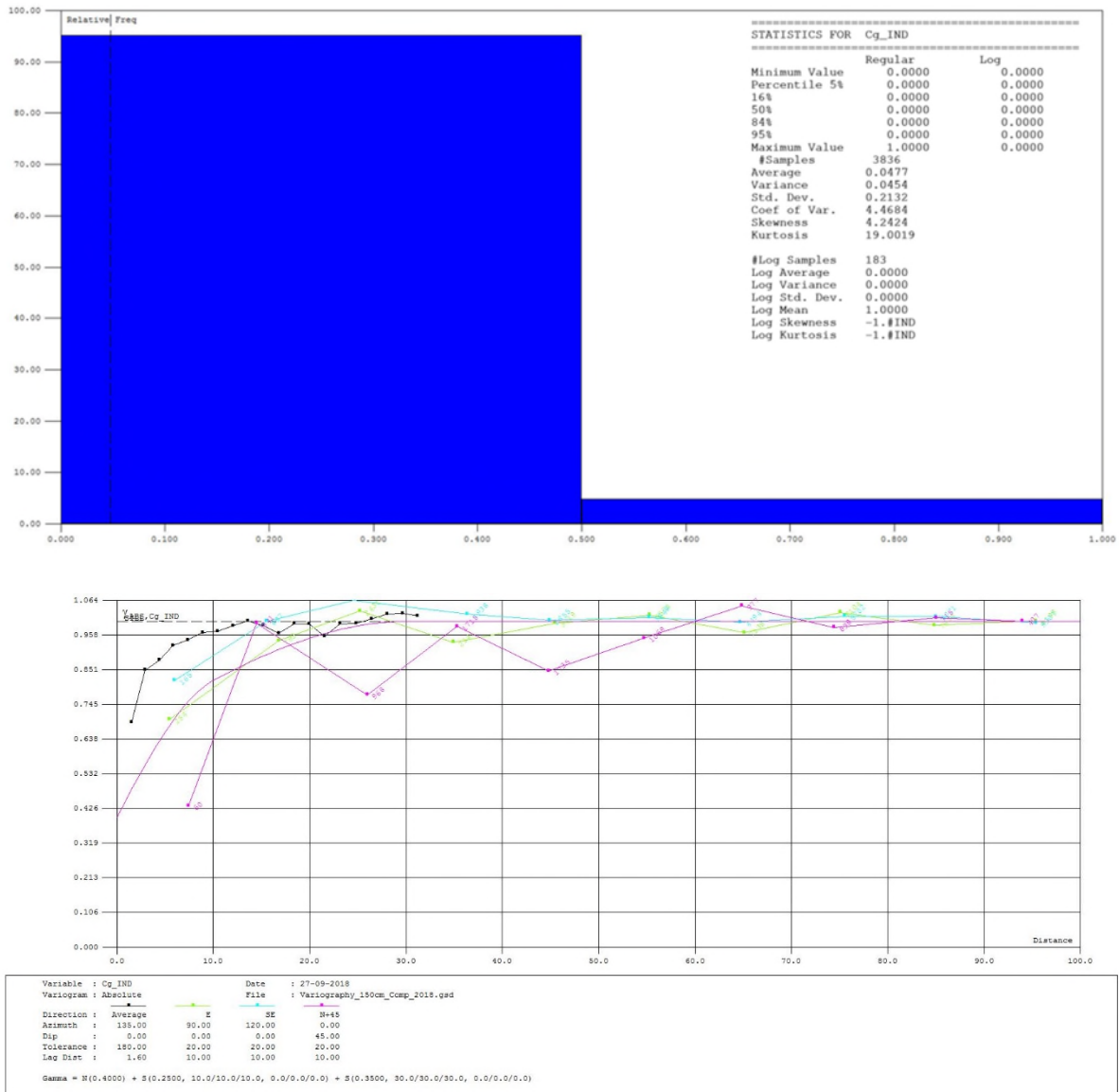

Figure 14-17: Indicator Statistics and Variographic Model

14.6 Density

In order to convert the volumes of the block models to tonnages in the Mineral Resource reporting, density measurements were conducted by Canada Carbon on witness core samples in the marble rock unit. A total of 48 measurements were made using the dry and immersed weights.

The density values vary from 2.59 to 2.98 t/m³ with an average value of 2.81 t/m³ (Figure 14-18). Given the low number of measurements and their distribution in space, it is not possible to interpolate the densities or correlate them to the graphite grades. Hence, a fixed density of 2.81 t/m³ was applied to all material in the block model.

In the future, more density measurements should be conducted and should be appropriately spaced along the drilling grid and distributed between the different rock types. The density poses a significant risk factor in the tonnage estimates of the mineral resources and should be better constrained with the project’s advancements. Additional density measurements will be conducted on the different lithologies and grade material in further exploration campaigns.

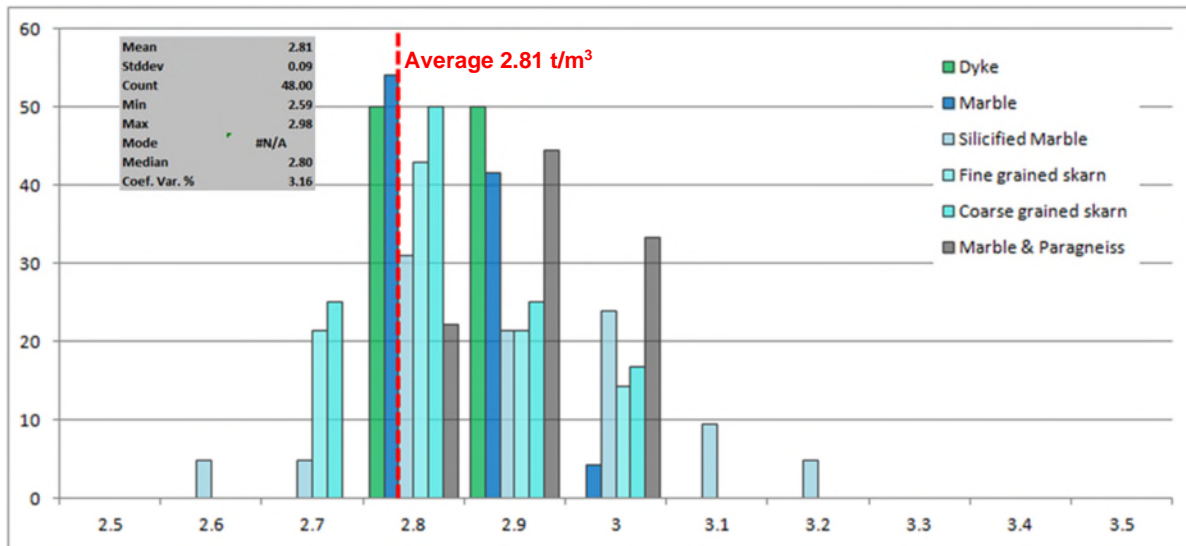

Figure 14-18: Statistical Distribution of the Density Measurements

14.7 Block Model

A block model was generated within the limits stated in Table 14-2. A total of 49,542 blocks were generated within the limits of the marble unit and graphite model combined (Figure 14-19). The blocks were limited at surface to the rock overburden interface.

Table 14-2: Block Model Grid Parameters

Grid	X	Y	Z
Origin (Center of First Block)	530,330	5,057,501	50
Edge of First Block	530,327.5	5,057,498.5	47.5
Size	5	5	5
Discretization	3	3	3
Starting Coordinates	530,330	5,057,501	50
Starting Indices	1	1	1
Ending Coordinates	531,425	5,058,346	250
Ending Indices	220	170	41

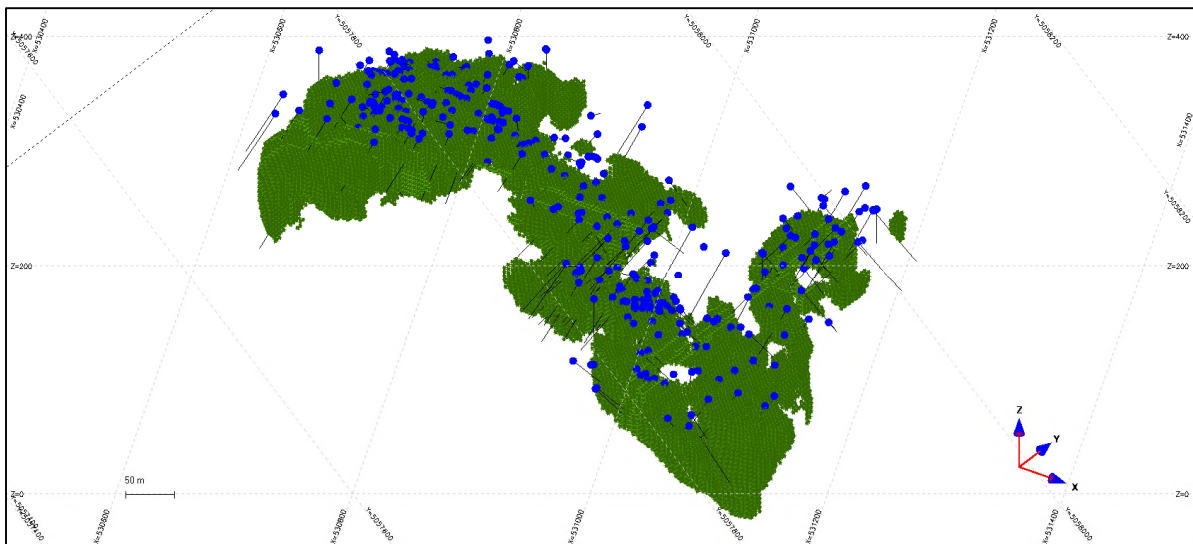

Figure 14-19: Block Model Used for Interpolation ($\geq 0.45\%$ Cg Model)

14.7.1 Search Ellipsoids

Given the continuity observed in the variographic studies, the sparse drilling grid, and the geological observations, three different search ellipsoids were used in the interpolation process (Figure 14-20). The Pass 1 search ellipsoid was designed to represent the low continuity in the data and interpolated blocks using a limited distance and composites inside that particular block, thus limiting the smoothing effect. The Pass 2 and Pass 3 ellipses were designed to enable interpolation on a broader distance with Pass 3 limited to the maximum extrapolation and interpolation in the mineralized solids.

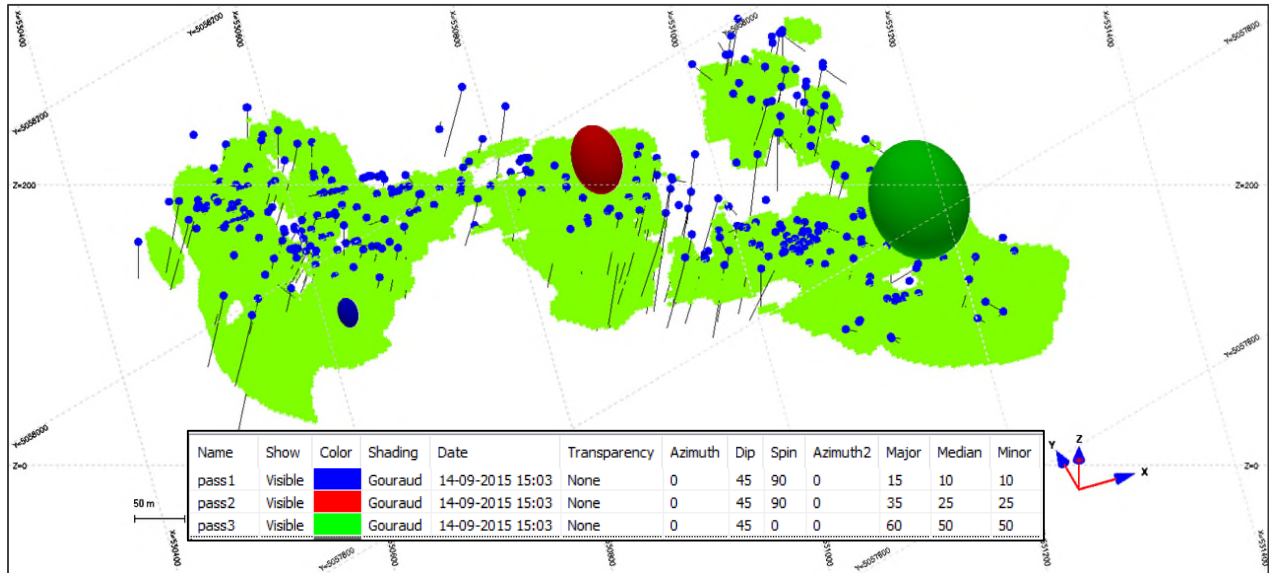

Figure 14-20: Search Ellipsoids

14.8 Block Model Interpolation

In order to interpolate the different block models, different sets of composites, solids, ellipses and parameters were generated (Table 14-3). This process enabled the use of the specific statistical properties of each zone during the interpolation process. All variables were interpolated using Ordinary Kriging (OK) method.

Table 14-3: Block Model Interpolation Parameters

Variable	Pass Number	Method	Ellipsoid	Minimum	Maximum	Maximum
				Comp	Comp	Comp per DDH
GraphiteLG	1	OK	pass1	5	9	2
GraphiteLG	2	OK	pass2	5	9	2
GraphiteLG	3	OK	pass3	3	9	2
GraphiteHG	1	OK	pass1	3	6	2
GraphiteHG	2	OK	pass2	3	6	2
Indicator	1	OK	pass1	2	7	2
Indicator	2	OK	pass2	2	7	2

14.8.1 Graphite Mineralization Interpolation

The different variables created in the compositing process were interpolated within the limits of the graphite mineralization solid (Figure 14-11). All the blocks inside the solid were interpolated using the parameters in Table 14-3 for the GraphiteLG variable. The GraphiteHG and Indicator (high-grade probability) were restricted to smaller search ellipsoids (Table 14-3) due to the discontinuous nature of the high-grade mineralization.

The three different variables were then used to re-calculate the graphite percentage (graphitic carbon) of each block. The GraphiteLG representing the bulk disseminated mineralization in the marble was then combined with the high-grade model (GraphiteHG) using the probability that the given block is actually high-grade material (Indicator). The final graphitic carbon grade of the block was calculated as follows:

Blocks with	Standard Interpolation	Selective Indicators	Grade source
0% high grade probability	One grade	One grade	Low grade Interpolation
10% high grade probability	One grade	One grade	Low grade Interpolation
20% high grade probability	One grade	One grade	Low grade Interpolation
30% high grade probability	One grade	One grade	Low grade Interpolation
40% high grade probability	One grade	One grade	Low grade Interpolation
50% high grade probability	One grade	One grade	Low grade Interpolation
60% high grade probability	One grade	One grade	Low grade Interpolation
70% high grade probability	One grade	One grade	High grade Interpolation
80% high grade probability	One grade	One grade	High grade Interpolation
90% high grade probability	One grade	One grade	High grade Interpolation
100% high grade probability	One grade	One grade	High grade Interpolation

$$Cg_{TOTAL} = \text{If Indicator} \geq 0.7 = \text{GraphiteHG}$$

$$= \text{If Indicator} \geq 0.7 = \text{GraphiteLG}$$

A total of 49,846 blocks were interpolated with the GraphiteLG variable (Figure 14-21), whereas the Indicator variable was interpolated in 44,320 blocks (Figure 14-21), with only 27,708 blocks containing GraphiteHG results (Figure 14-21). Not all the GraphiteHG interpolated blocks have Indicator values ranging from 0.1 to 1.

All the 49,846 blocks were re-calculated for the CgTOTAL variable with grades ranging from 0.02 to 9.36% graphitic carbon, with an average grade of 0.66% graphitic carbon (Figure 14-24). Given the statistical distribution of the original assays and composite original grades, the block model does not seem to over (or under) estimate the graphite grades (Figure 14-24). Furthermore, a good correlation is observed between the block grades and the composites located inside those blocks (Figure 14-24). Lastly, the swath plot makes for an acceptable level of smoothing and grade value across the x, y and z axis of the deposit..

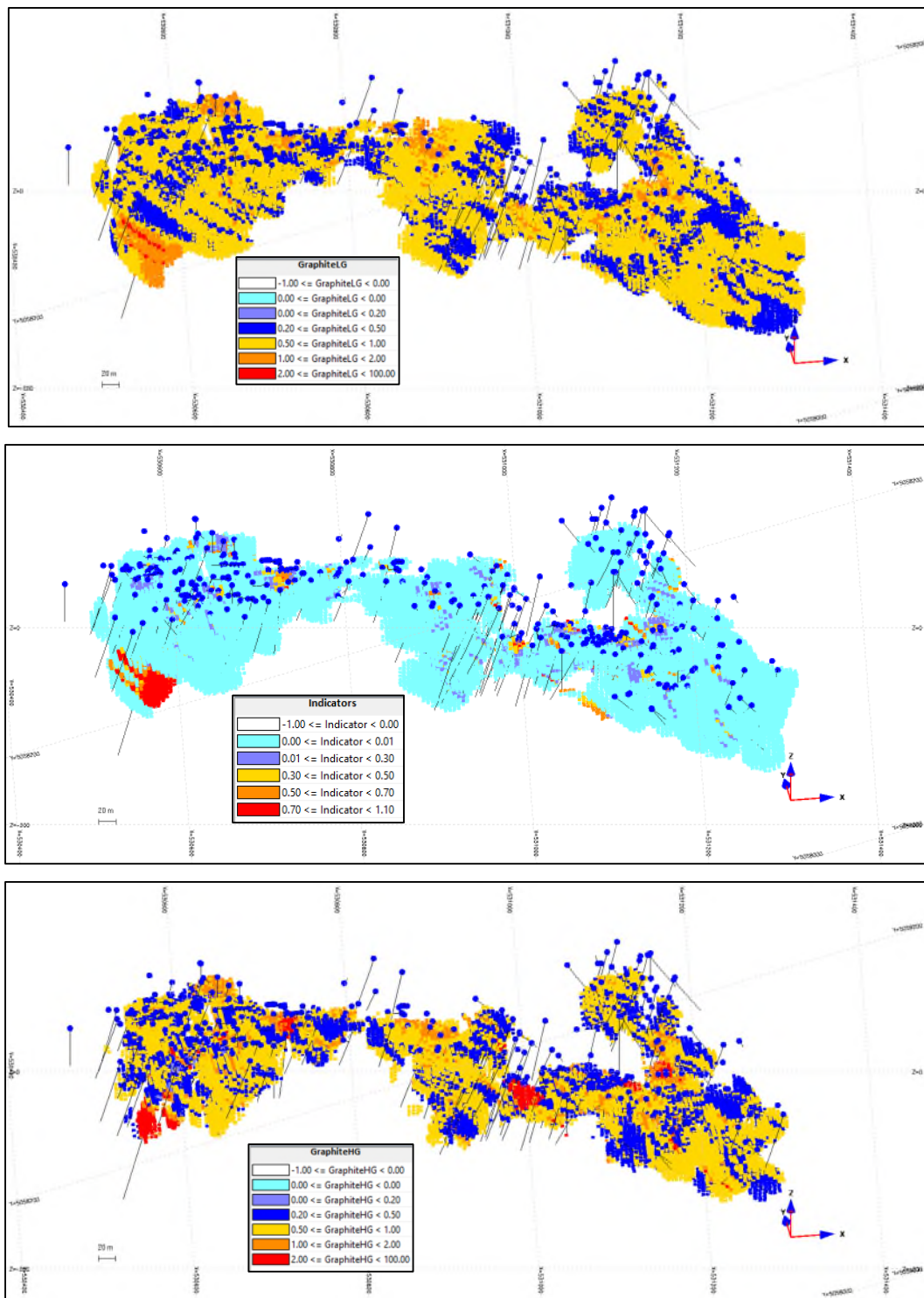

Figure 14-21: Block Model Images - GraphiteLG (Top), Indicator (Middle) and GraphiteHG (Bottom)

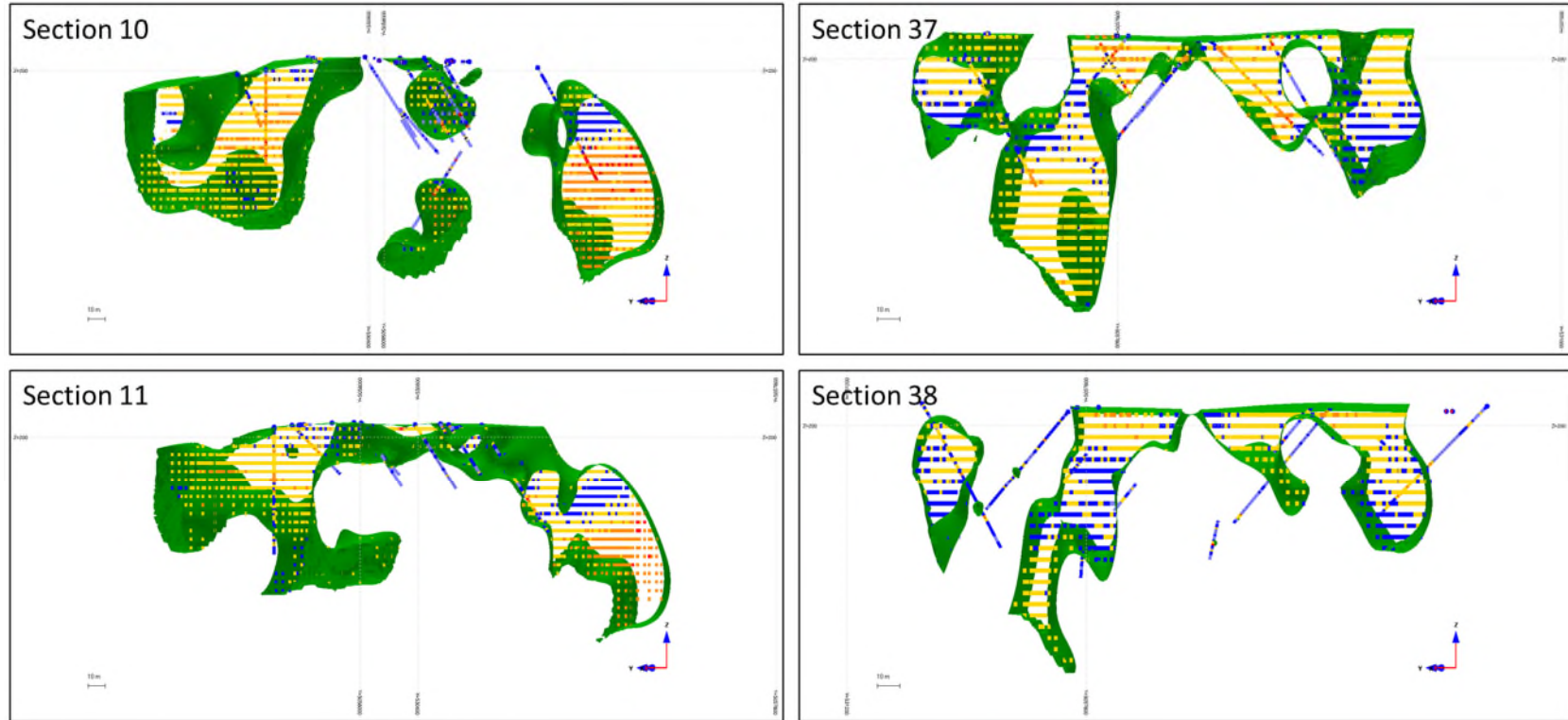

Figure 14-23: Validation of block model on sections

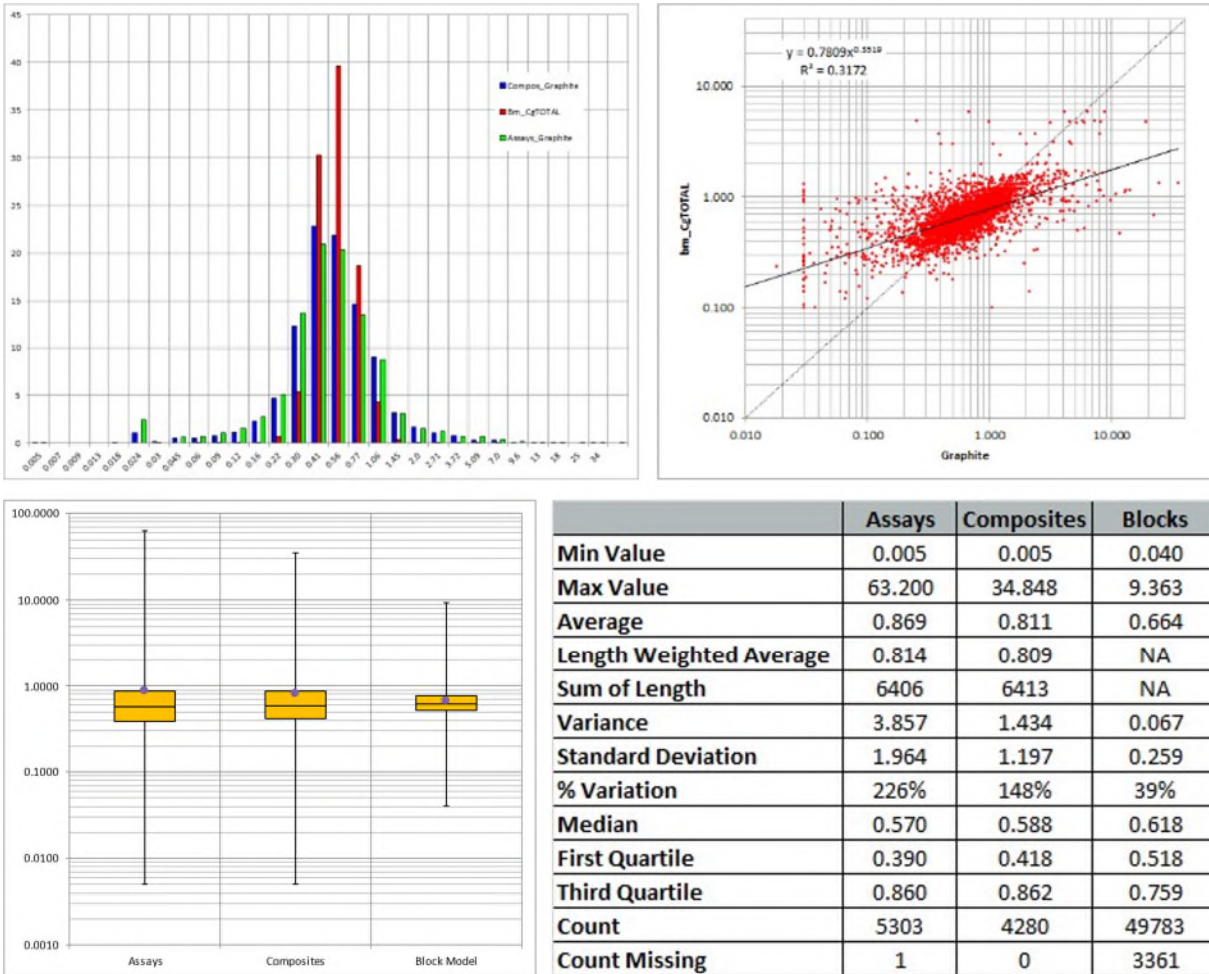

Figure 14-24: Results from the Block Model Validation Process

14.9 Block Model Classification

The Mineral Resource Estimate presented in this Technical Report was prepared and disclosed in compliance with all current disclosure requirements for mineral resources set out in the NI 43-101 Standards of Disclosure for Mineral Projects. The classification of the current Mineral Resource Estimate into Measured, Indicated and Inferred is consistent with current 2014 CIM Definition Standards for Mineral Resources and Mineral Reserves, including the critical requirement that all mineral resources “have reasonable prospects for eventual economic extraction”.

Mineral Resources are sub-divided, in order of increasing geological confidence, into Inferred, Indicated and Measured categories. An Inferred Mineral Resource has a lower level of confidence than that applied to an Indicated Mineral Resource. An Indicated Mineral Resource has a higher level of confidence than an Inferred Mineral Resource but has a lower level of confidence than a Measured Mineral Resource.

A Mineral Resource is a concentration or occurrence of solid material of economic interest in or on the Earth's crust in such form, grade or quality and quantity that there are reasonable prospects for eventual economic extraction.

Interpretation of the word 'eventual' in this context may vary depending on the commodity or mineral involved. For example, for some coal, iron, potash deposits and other bulk minerals or commodities, it may be reasonable to envisage 'eventual economic extraction' as covering time periods in excess of 50 years. However, for many gold deposits, application of the concept would normally be restricted to perhaps 10 to 15 years, and frequently to much shorter periods of time.

The location, quantity, grade or quality, continuity and other geological characteristics of a Mineral Resource are known, estimated or interpreted from specific geological evidence and knowledge, including sampling.

Measured Mineral Resource

A Measured Mineral Resource is that part of a Mineral Resource for which quantity, grade or quality, densities, shape, and physical characteristics are estimated with confidence sufficient to allow the application of Modifying Factors to support detailed mine planning and final evaluation of the economic viability of the deposit.

Geological evidence is derived from detailed and reliable exploration, sampling and testing and is sufficient to confirm geological and grade or quality continuity between points of observation.

A Measured Mineral Resource has a higher level of confidence than that applying to either an Indicated Mineral Resource or an Inferred Mineral Resource. It may be converted to a Proven Mineral Reserve or to a Probable Mineral Reserve.

Mineralization or other natural material of economic interest may be classified as a Measured Mineral Resource by the Qualified Person when the nature, quality, quantity and distribution of data are such that the tonnage and grade or quality of the mineralization can be estimated to within close limits and that variation from the estimate would not significantly affect potential economic viability of the deposit. This category requires a high level of confidence in, and understanding of, the geology and controls of the mineral deposit.

Indicated Mineral Resource

An 'Indicated Mineral Resource' is that part of a Mineral Resource for which quantity, grade or quality, densities, shape and physical characteristics can be estimated with a level of confidence sufficient to allow the appropriate application of technical and economic parameters, to support mine planning and evaluation of the economic viability of the deposit.

Geological evidence is derived from adequately detailed and reliable exploration, sampling and testing and is sufficient to assume geological and grade or quality continuity between points of observation.

An Indicated Mineral Resource has a lower level of confidence than that applying to a Measured Mineral Resource and may only be converted to a Probable Mineral Reserve.

Mineralization may be classified as an Indicated Mineral Resource by the Qualified Person when the nature, quality, quantity and distribution of data are such as to allow confident interpretation of the geological framework and to reasonably assume the continuity of mineralization. The Qualified Person must recognize the importance of the Indicated Mineral Resource category to the advancement of the feasibility of the project. An Indicated Mineral Resource Estimate is of sufficient quality to support a Preliminary Feasibility Study which can serve as the basis for major development decisions.

Inferred Mineral Resource

An Inferred Mineral Resource is that part of a Mineral Resource for which quantity and grade or quality are estimated on the basis of limited geological evidence and sampling. Geological evidence is sufficient to imply but not verify geological and grade or quality continuity.

An Inferred Mineral Resource has a lower level of confidence than that applying to an Indicated Mineral Resource and must not be converted to a Mineral Reserve. It is reasonably expected that the majority of Inferred Mineral Resources could be upgraded to Indicated Mineral Resources with continued exploration.

An Inferred Mineral Resource is based on limited information and sampling gathered through appropriate sampling techniques from locations such as outcrops, trenches, pits, workings and drill holes. Inferred Mineral Resources must not be included in the economic analysis, production schedules, or estimated mine life in publicly disclosed Pre-Feasibility or Feasibility Studies, or in the Life of Mine plans and cash flow models of developed mines. Inferred Mineral Resources can only be used in economic studies as provided under NI 43-101.

There may be circumstances, where appropriate sampling, testing, and other measurements are sufficient to demonstrate data integrity, geological and grade/quality continuity of a Measured or Indicated Mineral Resource, however, quality assurance and quality control, or other information may not meet all industry norms for the disclosure of an Indicated or Measured Mineral Resource. Under these circumstances, it may be reasonable for the Qualified Person to report an Inferred Mineral Resource if the Qualified Person has taken steps to verify the information meets the requirements of an Inferred Mineral Resource.

Given the generally irregular, complex nature of the deposit and the current state of mineralization event understanding in combination with the range of the variography, a drilling grid of at least 3 holes at more or less 40m is used to classify the resources to indicated. The classification in indicated was done as a separate step with an algorithm with ellipsoids centered on composites. Inferred are any estimated blocks not passing the indicated specifications.

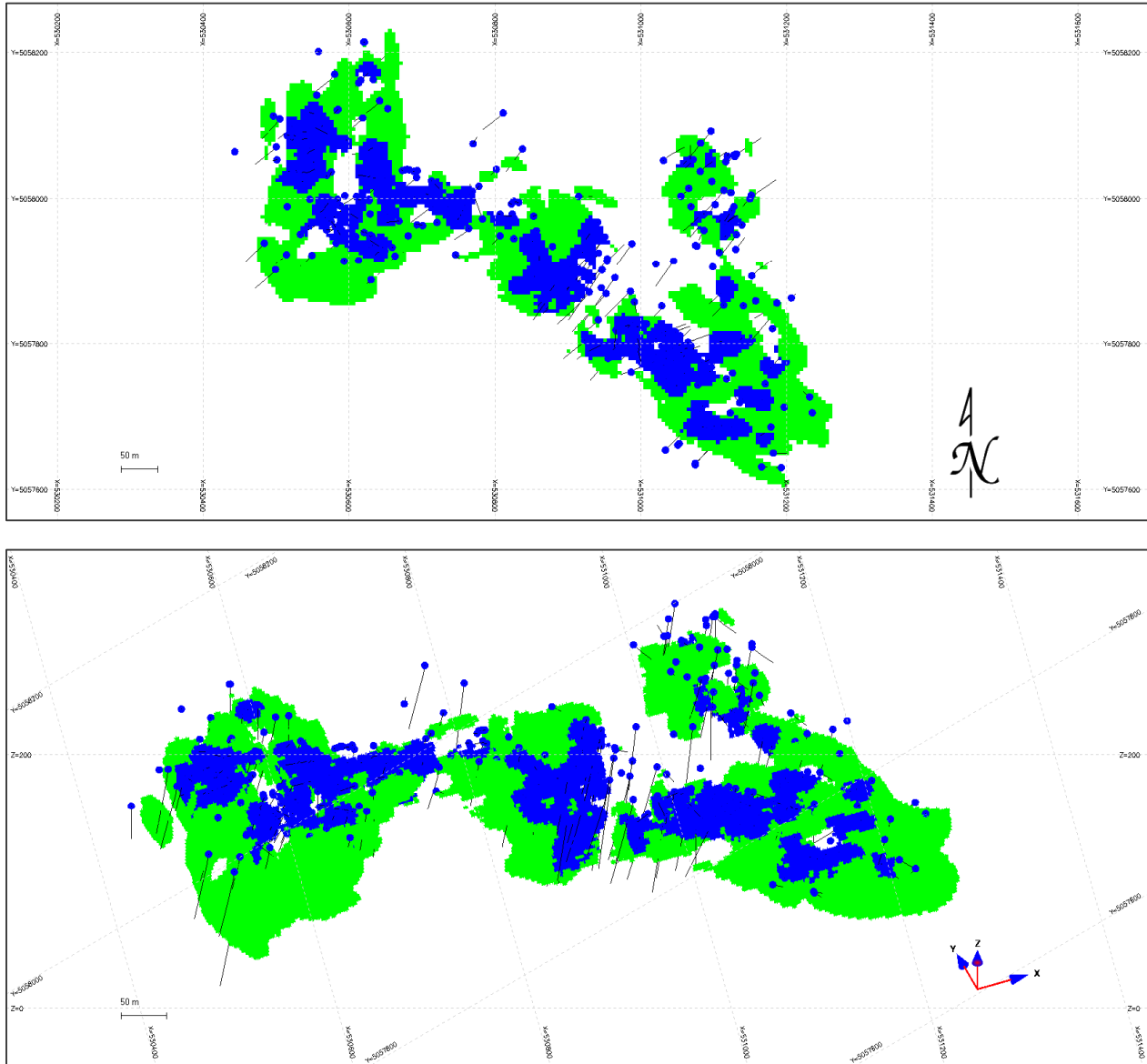

Figure 14-25: Surface Map of the Classified Block Model with Drill Hole Collars

14.10 Optimization Procedures and Parameters

Open pit optimizations were conducted on the Project to validate the Mineral Resources under the NI 43-101 requirements of “reasonable prospect of eventual economic extraction” (CIM 2014) for Mineral Resource reporting purposes. Graphite pit optimization, in which the CgTOTAL variable was used to generate optimized shells using the parameters in Table 14-4. The parameters are derived from the 2015

PEA report (see section 6) and were adjusted by SGS and Canada Carbon to better fit the current situation of the project. This scenario produced a pit shell with cut-off grade estimation at 0.5% graphitic carbon (Figure 14-26). The 40,000\$ USD metal price used for the optimization come from a MOU agreement signed in 2018 between Canada Carbon and Dunedin Energy System Ltd, an arm’s length Canadian developer of small modular nuclear reactors. Following MOU terms, Dunedin will by 200 of nuclear purity graphite over a 10-years term at 40,000\$USD. This MOU include an option to purchase up to an additional 50 tonnes in any single year of the agreement at a floor price 45,000\$USD.

Table 14-4: Graphite Mineral Resources Open Pit Optimization Parameters

Parameters	Value	Unit
Exchange Rate	0.75	CAD 1 = USD x
Mining Mineralized Material	7.24	\$/t mined
Mining Waste	3	\$/t mined
Mining Dilution	3.00	%
Mining Recovery	95	%
Crushing and Processing	37.07	\$/t milled
Treatment and Refining	1,560.34	\$/t conc.
General and Administration	8.21	\$/t mined
Freight Mine to Treatment	1.00	\$/t mined
Metal Price	40,000	\$/t sold USD
Concentration Recovery	88	%
Royalties	3.60	%
Pit Slopes	45	degrees
Density of Mineralized Material and Waste	2.81	t/m3

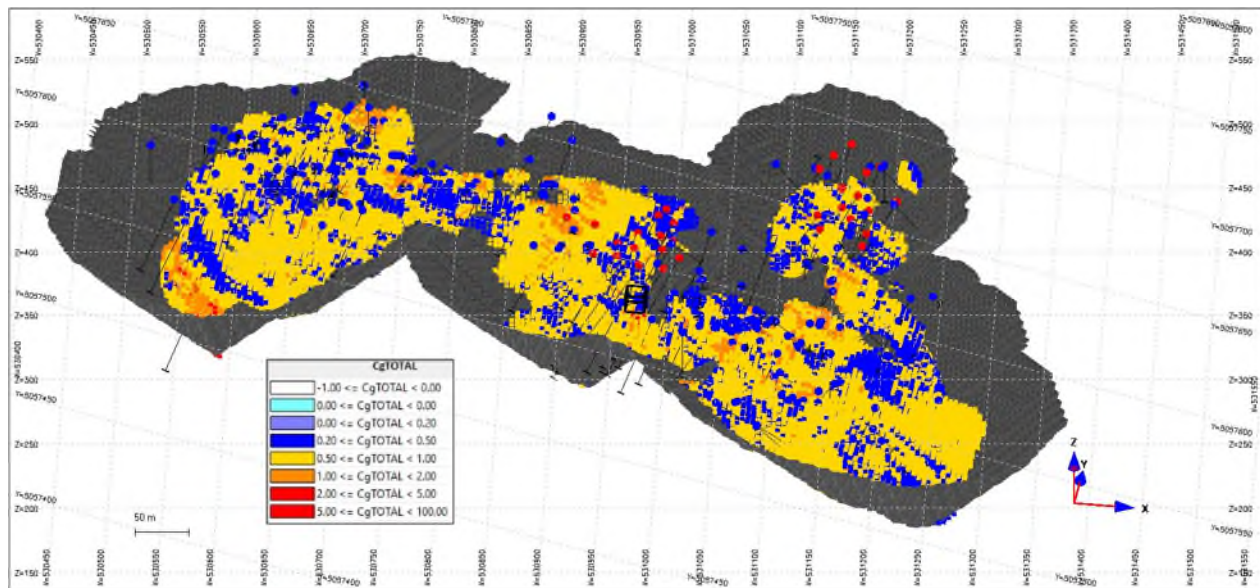

Figure 14-26: Optimized Pit Shell from the Graphite Scenario

14.11 Mineral Resources

14.11.1 Graphite Resources

The pit shell from the optimization scenario was used to limit the extent of the Mineral Resources at depth (Figure 14-26). The graphite pit contains 10,478,000 t of Inferred Resources at an average grade of 0.72% graphitic carbon (reported at a cut-off grade of 0.5% graphitic carbon) and 3,338,000 t of Indicated resources at an average grade of 0.75% graphitic carbon (Table 14-5).

Table 14-5: Graphite Mineral Resources

Cut-off Grade (%Cg)	Resource Category	Tonnage* (Mt)	Average Grade (%Cg)	Contained Graphite (t)
0.50	Indicated	3,338,000	0.75	25,200
0.50	Inferred	10,478,000	0.72	75,400

Notes: The mineral resource estimate has been conducted using the CIM Definitions Standards for mineral resources in accordance with National Instrument 43-101, Standards of Disclosure for Mineral Projects. Mineral Resources, which are not mineral reserves, do not have demonstrated economic viability. Inferred mineral resources are exclusive of the Indicated resources.
 A fixed density of 2.81 t/m³ was used to estimate the tonnage from block model volumes.
 The results from the pit optimization are used solely for the purpose of testing the “reasonable prospects for economic extraction” by an open pit and do not represent an attempt to estimate mineral reserves. There are no mineral reserves on the Property. The results are used as a guide to assist in the preparation of a Mineral Resource statement and to select an appropriate resource reporting cut-off grade
 Resources are constrained by the pit shell and the topography of the overburden layer
 All figures are rounded to reflect the relative accuracy of the estimate and numbers may not add due to rounding
 The estimate of Mineral Resources may be materially affected by environmental, permitting, legal, title, taxation, socio-political, marketing and other relevant issues
 Effective date November 8th, 2022

15 ADJACENT PROPERTIES

No known adjacent property has been explored for graphite resources, or any other commodities, in the direct vicinity of the Property.

16 INTERPRETATIONS AND CONCLUSIONS

Understanding of the deposit geology is still preliminary; an increase in drilling may significantly change the geometry and interpretation of the mineral deposit. Increasing the quantity of drillholes will greatly benefit understanding of the marble geometry and the distribution of the high-grade mineralization. The presence of faulting or displacing structures may also influence the reliability of the geological model.

SGS verified the work conducted by SL Exploration Inc. and is comfortable with what has been completed as of the effective date of this report. Changes may be needed in drilling management and data acquisition in order to increase classification of the Mineral Resources. These changes are discussed further in Section 17.

Geological and mineralized solids were modeled using Leapfrog's implicit modelling tool from 348 drillholes and surface channels using the assay values for graphitic carbon, at a modelling minimal value of 0.5% Cg. Numerous intercalated assays below this lower model value were still incorporated in the mineralized solids in order to respect the general geometry of the mineralization but were always surrounded (top and bottom) by an assay higher than the modeling value. Upon modeling the mineral zone, a block model was generated for the whole deposit (block size of 5 m by 5 m by 5 m). The block model was also limited at surface by the overburden surface, which was modeled using lithological information from drillholes.

Density measurements were conducted on drill core samples over the year and the values were used to generate a fixed density for each block. This fixed density value is not ideal but was the only possible outcome using the 48 density measurements made in the marble rock unit.

Variographic studies were conducted for each of the four variables for GraphiteLG, GraphiteHG and Indicator. The correlograms were used in the kriging process of the block interpolation but also to establish search ellipsoid parameters and classification criteria of the Mineral Resources. The classification also accounted for the quality of the data, the geological comprehension and drilling grid. Each variable was domained differently and interpolated using its own set of 1.5-m composite and parameters. Upon interpolation of the variables, the GraphiteLG, the GraphiteHG and the Indicator variable were used to calculate the total graphitic carbon content of each block.

16.1 Mineral Resources

The Mineral Resources for the Project are limited at depth by an optimized pit shell, in order to account for the "reasonable prospect of eventual economic extraction" of reported Mineral Resources under the NI 43-101 regulation. The optimization outlines the open pit that generates the maximum economic value. However, this value does not take into account mine planning and time value of money

(discounting rate). It is for this reason that there is no guarantee that this shell shall be selected as the base case scenario to develop the mining scenario, and thus, to calculate the eventual in-pit reserves.

The optimized pit shell scenario was also used to estimate a cut-off grade for reporting the mineral resources. The cut off grade used in this project is 0.5% Cg. The Mineral Resources comprise 10,478,000 t of Inferred graphite resources at an average grade of 0.72% graphitic carbon with an additional 3,338,000 t of Indicated graphite resources at an average grade of 0.75% graphitic carbon.

The current risks around the project revolve around:

1. Tonnage estimation variation due to changes in the mineralized material interpretation. Further drilling and surface exploration work could still change the geological interpretation associated with the deposit. This could result in a variation of plus or minus 50% of the estimated tonnage;
2. High grade distribution. The high grade (>2% Cg) estimation was conducted with the goal of representation the disrupted nature of the high grade zones observed in the field. However, the high grade zones cannot be followed from surface observation to drilling which make them practically impossible to measure. This would not affect the overall tonnage much and would have a limited impact of average grade (below 5% grade decrease);
3. Less than 5% of the Indicated resource's surface footprint lies over wetlands and/or vulnerable species habitat. Environmental compensation programs for other areas of the Property may have to be planned to finalize the mine permit to include those areas. Future exploration work to extend the Inferred resource category to Indicated could focus on areas without vulnerable species, north of the Miller Mine Pit, in between the two Indicated resource solids, and north of the VN6 area. This would limit the potential impact of the project on the environment. Otherwise, additional compensation programs might be necessary.

17 RECOMMENDATIONS

This section outlines the areas to investigate for project improvements and potential opportunities and risks for the Project. A high-level budgetary estimate for the completion of each recommended item is provided. Based on the results of the mineral resources estimation and the historical PEA (based much smaller mineral resources), SGS would recommend that Canada Carbon should continue with the next phase of the project, a planned Pre-Feasibility Study, in order to further assess the technical and economic viability of the project and identify potential opportunities and risks.

In order to increase the level of confidence in the Mineral Resources and better quantify the natural variability of the different grades, impacting the concentrate quantity, quality, and tonnage, SGS recommends the following:

- increase surface geological knowledge by conducting property scale and local mapping and structural study
- conduct further drilling on a constant grid to increase geological knowledge and sample distribution in the deposit
- follow drilling progress using drawn sections, plan and test the possible marble and skarn extension outside the main zone.

Table 17-17-1: Estimated Budget for Geological Recommendations

Items	Timeframe	Priority	Estimated Budget (\$)
Surface Mapping and Structural Study	Summer 2023	1	50,000
Drilling, logging and assaying	Spring-Summer 2023	1	500,000
Metallurgical testing	Summer 2023	1	400,000
Pre-Feasibility Study	2023-2024	2	650,000
Total			1,600,000

Preliminary test work has been completed for the Project to evaluate the metallurgical performances of various head grade samples, including a large-scale pilot plant campaign. To better understand the metallurgical performances of the mineralization and to support next phase study and design work, additional test work should be conducted, especially thermal purification tests. The recommended test work for the graphite recovery and purification proposed includes:

- verification of metallurgical responses of the samples
- further optimization of process conditions and improvement of graphite recovery and product grade
- conducting variability flotation and thermal treatment tests to evaluate the metallurgical performances of the samples from different rock zones, lithological zones and spatial locations and the samples representative of the proposed mine plan
- confirming and establishing process design related parameters, including comminution related data and concentrate and tailings dewatering characteristics.
- conducting environmental related tests to quantify the properties of the flotation tailings, waste rocks and the waste streams generated from thermal treatment, such as off-gases and solids collected from the gases
- determining efficient and cost effective methods for handling the off-gases that are anticipated to be generated from the proposed thermal treatment.

The estimated cost for this test work is approximately \$400,000, including sample collection and shipment.

Further optimizations on plant designs, including primary comminution circuits, flotation and regrinding circuits, and thermal upgrading circuits and related layouts, are recommended. The costs associated with the optimizations will be included in the costs for the next phase of study.

18 REFERENCES

- 1 Baiju, K.R., Satish-Kumar, M., Kagi, H., Nambiar, C.G. et Ravisankar, M., 2005, Mineralogical Characterization of Graphite Deposits from Thodupuzha-Kanjirappally Belt, Madurai Granulite Block, Southern India; *Gondwana Research*, v . 9, p. 223-230.
- 2 Blair, G.A., 1988a, Preliminary geological-geophysical report, central area claimblock; GM 47899, 3 p. 1 map.
- 3 Blair, G.A., 1988b, Preliminary geological-geophysical report, "east-central" area claimblock; GM 47971, 4 p. 1 map.
- 4 Boivin, M., 2013, Detailed mobile TDEM survey on Miller-Graphite Property - East Block, Grenville Township, Québec, Hawkesbury area, 31G/10; Geosig Inc for Canada Carbon Inc., internal report, 14 p. 2 maps.
- 5 Cirkel, Fritz, M. E., 1907, Graphite : its properties, occurrence, refining and uses; Department of Mines (Mines Branch), Ottawa, Canada, 307 p. 7 maps
- 6 Corriveau, L. and van Breemen, O., 2000, Docking of the Central Metasedimentary Belt to Laurentia in geon 12: evidence from the 1.17–1.16 Ga Chevreuil intrusive suite and host gneisses, Quebec; *Canadian Journal of Earth Sciences*, v. 37 p. 253-269.
- 7 Corriveau, L. Perreault, S. and Davidson, A., 2007 Prospective metallogenic settings of the Grenville Province, in Goodfellow, W.D., ed., *Mineral Deposits of Canada: A Synthesis of Major Deposit-Types, District Metallogeny, the Evolution of Geological Provinces, and Exploration Methods: Geological Association of Canada, Mineral Deposits Division, Special Publication No. 5, P. 819-847.*
- 8 Corriveau, L., Rivard, B., and van Breemen, O. 1998; Rheological controls on Grenvillian intrusive suites: implications for tectonic analysis; *Journal of Structural Geology*, vol. 20, p. 1191–1204.
- 9 Ells R.W., 1904, Graphite in Canada; in *Mineral resources of Canada, Bulletin 1904*; Geological Survey of Canada, 213 p.
- 10 Glassley, W., 1982, Fluid evolution and graphite genesis in the deep continental crust; *Nature*, 295, 229 31.
- 11 Han, Z. and Prikhodko, A., 2013a (September), The results of EMIT Maxwell Plate Modelling of selected VTEM anomaly from East Block, Grenville, Quebec; Geotech Ltd. for Canada Carbon Inc., internal report, 24 p.
- 12 Han, Z. And Prikhodko, A., 2013b (September), The results of EMIT Maxwell Plate Modelling of selected VTEM anomaly from West Block, Grenville, Quebec; Geotech Ltd. for Canada Carbon Inc., internal report, 22 p.
- 13 Katz, M.B., 1987, Graphite deposits of Sri Lanka: a consequence of granulite facies metamorphism; *Mineralium Deposita*, vol. 22, p. 18-25.
- 14 Lachance, L., 1954, Miller Graphite Mine Map; GM 05774, 1 map.
- 15 Logan, W.E., 1863, *Geology of Canada*; Geological Survey of Canada, report of progress to 1963, 983 p.

- 16 Longuépée, H. 2008. Nouveaux modèles d'exploration dans le Grenville : Opportunités de gisements de type skarn, for Groupe Consorem, 28 pages.
- 17 Luque, F.J., Huizenga, J.-M., Crespo-Feo, E., Wada, H., Ortega, L. And Barrenechea, J.F., 2013, Vein graphite deposits: geological setting, origin, and economic significance; Mineralium Deposita, published online, Sept. 2013.
- 18 Martignole, J., and Friedman, R. 1998, Geochronological constraints on the last stages of terrane assembly in the central part of the Grenville Province; Precambrian Research, vol. 92, p. 145–164.
- 19 Martignole, J., Calvert, A.J., Friedman, R., and Reynolds, P. 2000. Crustal evolution along a seismic section across the Grenville Province (western Quebec); Canadian Journal of Earth Sciences, vol. 37: p. 291–306.
- 20 Maurice, O.D., 1973, Annotated list of occurrences of Industrial Minerals and Building Materials in Quebec; MRN, DP 184, 580 pages.
- 21 Ministry of Natural Resources, 2012. GESTIM, Mining Rights Management. <https://gestim.mines.gouv.qc.ca>. Quebec claim maps.
- 22 Obalski, J., 1900, Mining Operations in the Province of Québec during the year 1900; Department of colonization and mines, 37 p. (http://sigeom.mrn.gouv.qc.ca/signet/classes/I1102_index : report number “OM 1900”).
- 23 Obalski, J., 1901, Opération minière dans la province de Québec pour l'année 1901; Département des Terres, Mines et Pêcherie, OM 1901, 50 p.
- 24 Paré, C., 1982, Développement Graphite; Ministère de l'Énergie et des Ressources, S.I.S.E.M., GM 51689, 59 p. 1 map.
- 25 Philpotts, A.R., 1961, Geological report on the southeastern part of Grenville Township, Argenteuil County; Ministère de l'Énergie et des Ressources du Québec; DP-12, 46 p.
- 26 Philpotts, A.R., 1976, Grenville Township (SE part); Ministère des Richesses Naturelles, Geological Report, RG-156, 51 p. 1 map.
- 27 Pope, E., 2004, Calcite-graphite and calcite-dolomite thermometry of high pressure marbles and calcsilicates: Syros, Cyclades, Greece; 17th Keck Symposium Volume, 4 p.
- 28 Radhika, U. P., Santosh, M. and Wada, H., 1995, Graphite occurrences in Southern Kerala: Characteristics and genesis; Journal of the Geological Society of India, vol. 45, p. 653-666.
- 29 Rodas, M., Luque, F.J., Barrenechea, J.F., Fernández-Caliani, J.C., Miras, A. And Fernandez-Rodriguez, C., 2000, Graphite occurrence in the low-pressure/high-temperature metamorphic belt of the Sirra de Aracena (southern Iberia Massif); Mineralogical Magazine, v. 64, p. 801-814.
- 30 Simandl, G.J. and Kenan, W.M., 1997, Vein graphite in metamorphic terrains; BC Geological Survey, geological fieldwork for 1997, 3 p.
- 31 Simoneau, Pierre and Boivin, Marc, 2013, HLEM-MaxMin, TDEM, Beep Mat and Induced Polarization Surveys on Miller-Graphite Property – East Block Grenville Township, Québec, Hawkesbury area, 31G/10, report; Geosig Inc. for Canada Carbon Inc., internal report, 21 p., 6 maps

- 32 Skippen, G. B and Marshall, D.D., 1991, The metamorphism of granulites and devolatilization of the lithosphere; Canadian Mineralogist, v. 29, p. 693-705.
- 33 Spence, H.S., 1920, Graphite in Canada; Canada Mines Branch, Publication No 511, 240 p.
- 34 Tremblay, A., et Cummings, J.G., 1987, Programme d'exploration 1986-87 pour le graphite dans l'Outaouais; Roche Groupe Conseil inc. pour Stratmin inc., GM 45932, 375 p. 27 maps
- 35 Vender, N., and Orta, M., 2013, Report on a helicopter-borne versatile time domain electromagnetic (VTEM+) and horizontal magnetic gradiometer geophysical survey, East and West block, Grenville, Quebec, Canada; Geotech inc pour Canada Carbon Inc., project GL130281, internal report, 67 p. 6 maps
- 36 Weis L, Friedman I, Gleason J., 1981, The origin of epigenetic graphite: evidence from isotopes; Geochimica Cosmochimica Acta, v. 45, p. 2325–2332.
- 37 SGS Canada Inc., July 2015, An investigation into a pilot plant campaign on a bulk sample from the Miller graphite deposit, Project # 14185-001/002.
- 38 SGS Canada Inc., Feb 2015, An investigation into a pilot plant campaign on a bulk sample from the Miller graphite deposit, Project # 14185-004.
- 39 SGS Canada Inc., August 2015, An investigation into a pilot plant campaign on a bulk sample from the Miller graphite deposit, Project # 14185-005.
- 40 SGS Canada Inc., April to June 2014, Data Reports, Project # 14185-003.
- 41 Rémi Charboneau and Steven Lauzier, April 25, 2014, Technical Report on the Miller Mine Graphite Property, Grenville Township, Quebec, Canada.
- 42 SGS Canada Inc., January 23, 2017, NI 43-101 Technical Report for the Mineral Resources Estimation of the Miller Project, Grenville Quebec Canada Carbon Inc.
- 43 Tetra Tech, March 4, 2016, Technical Report and Preliminary Economic Assessment for the Miller Graphite and Marble Property, Grenville Township, Quebec, Canada.
- 44 Evans Analytical Group, Jan 14, 2014 RAMAN Analysis Report (Job Number S0DKM997).
- 45 Evans Analytical Group, GDMS Analytical Reports.

19 QUALIFICATION CERTIFICATES

19.1 Qualification Certificate – Marc-Antoine

I, Marc-Antoine Laporte, P.Geo., M.Sc., of Quebec, Quebec, do hereby certify:

1. I am a Senior Geologist with SGS Canada Inc. with a business address at 125 rue Fortin, Suite 100, Quebec, Quebec, G1M 3M2.
2. This certificate applies to the technical report entitled “NI 43-101 TECHNICAL REPORT for the Mineral Resources Estimation of the Miller Project 2022 Update, Grenville, Quebec” dated December 30, 2022 (the “Technical Report”).
3. I am a graduate of Université Laval (B.A. 2004) and from Université Laval (M.Sc. Geology, 2008). I am a member in good standing of Ordre des Géologues du Québec (#1347). I have worked as a geologist continuously since my graduation.
4. I have read the definition of Qualified Person set out in the National Instrument 43-101 (NI 43-101) and certify that by reason of my education, affiliation with a professional association and past relevant work experiences, I fulfil the requirement to be an independent qualified person for the purposes of NI 43-101.
5. My personal inspections of the Property were on October 7-8, 2016 and on August 1st, 2018.
6. I am responsible for all Sections of the Technical Report except Section 12.
7. I am independent of Canada Carbon Inc. as defined by Section 1.5 of the Instrument.
8. I have read the Instrument and sections of the Technical Report I am responsible for have been prepared in compliance with the Instrument.
9. As of the date of this certificate, to the best of my knowledge, information and belief, the sections of the Technical Report that I am responsible for contain all scientific and technical information that is required to be disclosed to make the technical report not misleading.

Signed and dated this December 30, 2022 at Saint-Augustin-de-Desmaures, Quebec.

“Original Signed and Sealed”

Marc-Antoine Laporte, P.Geo., M.Sc.

Senior Geologist – Geological Services

SGS Canada Inc.



19.2 Qualification Certificate – Yann Camus

I, Yann Camus, P.Eng., of Val-Morin, Quebec, do hereby certify:

1. I am a Mineral Resource Estimation Engineer for SGS Canada Inc, - SGS Geological Services with an office at 10 Boul. de la Seigneurie Est, Suite 203, Blainville Quebec Canada, J7C 3V5.
2. This certificate applies to the technical report entitled "NI 43-101 TECHNICAL REPORT for the Mineral Resources Estimation of the Miller Project 2022 Update, Grenville, Quebec" dated December 30, 2022 (the "Technical Report").
3. I am a graduate of the École Polytechnique de Montréal (B.Sc. Geological Engineer, in 2000). I am a member of good standing, No. 125443, of the l'Ordre des Ingénieurs du Québec (Order of Engineers of Quebec). My relevant experience includes continuous mineral resource estimation since my graduation from University including graphite projects. I am a "Qualified Person" for purposes of National Instrument 43-101 (the "Instrument").
4. I have read the definition of Qualified Person set out in the National Instrument 43-101 (NI 43-101) and certify that by reason of my education, affiliation with a professional association and past relevant work experiences, I fulfil the requirement to be an independent qualified person for the purposes of NI 43-101.
5. My personal inspections of the Property were on October 13, 2017 and on December 9, 2022.
6. I am responsible for Section 12 of the Technical Report.
7. I am independent of Canada Carbon Inc. as defined by Section 1.5 of the Instrument.
8. I have read the Instrument and sections of the Technical Report I am responsible for have been prepared in compliance with the Instrument.
9. As of the date of this certificate, to the best of my knowledge, information and belief, the sections of the Technical Report that I am responsible for contain all scientific and technical information that is required to be disclosed to make the technical report not misleading.

Signed and dated this December 30, 2022 at San-Pancho, Nayarit, Mexico.

"Original Signed and Sealed"

Yann Camus, P.Eng.

Mineral Resource Estimation Engineer – Geological Services

SGS Canada Inc.



APPENDIX 1: CLAIM LIST

Title Number	Ownership	Ownership %	Map Sheet	Area (Ha)	Status	Date Emitted	Date Expiry	Excess Work	Restrictions
2299284	Canada Carbon Inc. (91295)	100%	31G10	60.1	Active	2011/7/13	2024/7/12	\$ 106,935	Affected by: Fauna habitat
2303792	Canada Carbon Inc. (91295)	100%	31G10	60.1	Active	2011/7/27	2024/7/26	\$ -	Affected by: Fauna habitat
2327928	Canada Carbon Inc. (91295)	100%	31G10	60.1	Active	2011/12/9	2024/12/8	\$ -	Affected by: Fauna habitat
2327929	Canada Carbon Inc. (91295)	100%	31G10	60.1	Active	2011/12/9	2024/12/8	\$ -	Affected by: Fauna habitat
2327930	Canada Carbon Inc. (91295)	100%	31G10	60.1	Active	2011/12/9	2024/12/8	\$ -	Affected by: Fauna habitat
2327931	Canada Carbon Inc. (91295)	100%	31G10	60.1	Active	2011/12/9	2024/12/8	\$ -	Affected by: Fauna habitat
2327932	Canada Carbon Inc. (91295)	100%	31G10	60.1	Active	2011/12/9	2024/12/8	\$ -	Affected by: Fauna habitat
2327933	Canada Carbon Inc. (91295)	100%	31G10	60.1	Active	2011/12/9	2024/12/8	\$ -	Affected by: Fauna habitat
2327934	Canada Carbon Inc. (91295)	100%	31G10	60.1	Active	2011/12/9	2024/12/8	\$ -	Affected by: Fauna habitat
2344486	Canada Carbon Inc. (91295)	100%	31G10	60.1	Active	2012/5/11	2023/5/10	\$ 16,874	Affected by: Fauna habitat
2344487	Canada Carbon Inc. (91295)	100%	31G10	60.1	Active	2012/5/11	2023/5/10	\$ -	Affected by: Fauna habitat
2344488	Canada Carbon Inc. (91295)	100%	31G10	60.09	Active	2012/5/11	2023/5/10	\$ 49,920	Affected by: Fauna habitat
2349738	Canada Carbon Inc. (91295)	100%	31G10	60.1	Active	2012/6/7	2023/6/6	\$ -	Affected by: Fauna habitat
2349739	Canada Carbon Inc. (91295)	100%	31G10	60.1	Active	2012/6/7	2023/6/6	\$ -	Affected by: Fauna habitat
2349740	Canada Carbon Inc. (91295)	100%	31G10	60.1	Active	2012/6/7	2023/6/6	\$ -	Affected by: Fauna habitat
2349741	Canada Carbon Inc. (91295)	100%	31G10	60.11	Active	2012/6/7	2023/6/6	\$ -	Affected by: Fauna habitat
2349742	Canada Carbon Inc. (91295)	100%	31G10	60.1	Active	2012/6/7	2023/6/6	\$ 16,473	Affected by: Fauna habitat
2349743	Canada Carbon Inc. (91295)	100%	31G10	60.09	Active	2012/6/7	2023/6/6	\$ -	Affected by: Fauna habitat
2349744	Canada Carbon Inc. (91295)	100%	31G10	60.09	Active	2012/6/7	2023/6/6	\$ 17,562	Affected by: Fauna habitat
2349745	Canada Carbon Inc. (91295)	100%	31G10	60.08	Active	2012/6/7	2023/6/6	\$ -	Affected by: Fauna habitat
2380944	Canada Carbon Inc. (91295)	100%	31G10	60.11	Active	2013/3/4	2024/3/3	\$ -	Affected by: Fauna habitat
2380945	Canada Carbon Inc. (91295)	100%	31G10	60.1	Active	2013/3/4	2024/3/3	\$ -	Affected by: Fauna habitat
2380948	Canada Carbon Inc. (91295)	100%	31G10	60.07	Active	2013/3/4	2024/3/3	\$ -	Affected by: Fauna habitat
2388715	Canada Carbon Inc. (91295)	100%	31G10	60.11	Active	2013/8/7	2024/8/6	\$ -	Affected by: Fauna habitat
2388716	Canada Carbon Inc. (91295)	100%	31G10	60.11	Active	2013/8/7	2024/8/6	\$ -	Affected by: Fauna habitat



Title Number	Ownership	Ownership %	Map Sheet	Area (Ha)	Status	Date Emitted	Date Expiry	Excess Work	Restrictions
2388717	Canada Carbon Inc. (91295)	100%	31G10	60.11	Active	2013/8/7	2024/8/6	\$ -	Affected by: Fauna habitat
2388718	Canada Carbon Inc. (91295)	100%	31G10	60.11	Active	2013/8/7	2024/8/6	\$ -	Affected by: Fauna habitat
2388719	Canada Carbon Inc. (91295)	100%	31G10	60.11	Active	2013/8/7	2024/8/6	\$ -	Affected by: Fauna habitat
2388720	Canada Carbon Inc. (91295)	100%	31G10	60.11	Active	2013/8/7	2024/8/6	\$ -	Affected by: Fauna habitat
2388721	Canada Carbon Inc. (91295)	100%	31G10	60.1	Active	2013/8/7	2024/8/6	\$ -	Affected by: Fauna habitat
2388722	Canada Carbon Inc. (91295)	100%	31G10	60.09	Active	2013/8/7	2024/8/6	\$ -	Affected by: Fauna habitat
2487820	Canada Carbon Inc. (91295)	100%	31G10	60.11	Active	2017/3/27	2024/3/26	\$ -	Affected by: Fauna habitat, Urbanization perimeter
2487825	Canada Carbon Inc. (91295)	100%	31G10	60.11	Active	2017/3/27	2024/3/26	\$ -	Affected by: Fauna habitat, Urbanization perimeter
2487829	Canada Carbon Inc. (91295)	100%	31G10	60.09	Active	2017/3/27	2024/3/26	\$ -	Affected by: Fauna habitat
2487830	Canada Carbon Inc. (91295)	100%	31G10	60.09	Active	2017/3/27	2024/3/26	\$ -	Affected by: Fauna habitat
2487831	Canada Carbon Inc. (91295)	100%	31G10	60.09	Active	2017/3/27	2024/3/26	\$ -	Affected by: Fauna habitat
2487832	Canada Carbon Inc. (91295)	100%	31G10	60.08	Active	2017/3/27	2024/3/26	\$ -	Affected by: Fauna habitat
2487833	Canada Carbon Inc. (91295)	100%	31G10	60.08	Active	2017/3/27	2024/3/26	\$ -	Affected by: Fauna habitat
2487836	Canada Carbon Inc. (91295)	100%	31G10	60.07	Active	2017/3/27	2024/3/26	\$ -	Affected by: Fauna habitat
2487837	Canada Carbon Inc. (91295)	100%	31G10	60.07	Active	2017/3/27	2024/3/26	\$ -	Affected by: Fauna habitat
2487838	Canada Carbon Inc. (91295)	100%	31G10	60.07	Active	2017/3/27	2024/3/26	\$ -	Affected by: Fauna habitat
2487839	Canada Carbon Inc. (91295)	100%	31G10	60.07	Active	2017/3/27	2024/3/26	\$ -	Affected by: Fauna habitat
2487843	Canada Carbon Inc. (91295)	100%	31G10	60.09	Active	2017/3/27	2024/3/26	\$ -	Affected by: Fauna habitat
2487844	Canada Carbon Inc. (91295)	100%	31G10	60.09	Active	2017/3/27	2024/3/26	\$ -	Affected by: Fauna habitat
2487845	Canada Carbon Inc. (91295)	100%	31G10	60.08	Active	2017/3/27	2024/3/26	\$ -	Affected by: Fauna habitat
2487846	Canada Carbon Inc. (91295)	100%	31G10	60.08	Active	2017/3/27	2024/3/26	\$ -	Affected by: Fauna habitat
2487847	Canada Carbon Inc. (91295)	100%	31G10	60.08	Active	2017/3/27	2024/3/26	\$ -	Affected by: Fauna habitat
2487854	Canada Carbon Inc. (91295)	100%	31G10	60.08	Active	2017/3/27	2024/3/26	\$ -	Affected by: Fauna habitat
2487855	Canada Carbon Inc. (91295)	100%	31G10	60.08	Active	2017/3/27	2024/3/26	\$ -	



Title Number	Ownership	Ownership %	Map Sheet	Area (Ha)	Status	Date Emitted	Date Expiry	Excess Work	Restrictions
2487856	Canada Carbon Inc. (91295)	100%	31G10	60.07	Active	2017/3/27	2024/3/26	\$ -	Affected by: Fauna habitat
2487857	Canada Carbon Inc. (91295)	100%	31G10	60.07	Active	2017/3/27	2024/3/26	\$ -	
2487858	Canada Carbon Inc. (91295)	100%	31G10	60.07	Active	2017/3/27	2024/3/26	\$ -	
2487990	Canada Carbon Inc. (91295)	100%	31G10	60.06	Active	2017/3/29	2024/3/28	\$ -	Affected by: Fauna habitat
2487991	Canada Carbon Inc. (91295)	100%	31G10	60.06	Active	2017/3/29	2024/3/28	\$ -	Affected by: Fauna habitat